



## Configuring UDLD

This chapter describes how to configure the UniDirectional Link Detection (UDLD) protocol on the Catalyst enterprise LAN switches.



### Note

For complete syntax and usage information for the commands used in this chapter, refer to the *Catalyst 5000 Family Command Reference*.

This chapter consists of these sections:

- [Understanding How UDLD Works, page 24-1](#)
- [UDLD Software and Hardware Requirements, page 24-2](#)
- [Default UDLD Configuration, page 24-3](#)
- [Configuring UDLD, page 24-3](#)

## Understanding How UDLD Works

The UDLD protocol allows devices connected through fiber-optic or copper Ethernet cables (for example, Category 5 cabling) to monitor the physical configuration of the cables and detect when a unidirectional link exists. When a unidirectional link is detected, UDLD shuts down the affected port and alerts the user. Unidirectional links can cause a variety of problems, including spanning-tree topology loops.

UDLD is a Layer 2 protocol that works with Layer 1 mechanisms such as autonegotiation to determine the physical status of a link. At Layer 1, autonegotiation handles physical signaling and fault detection. UDLD also performs tasks that autonegotiation cannot perform such as detecting the identities of neighbors and shutting down misconnected ports. When both autonegotiation and UDLD are enabled, Layer 1 and Layer 2 detection features can work together to prevent physical and logical unidirectional connections and malfunctioning of other protocols.

A unidirectional link occurs whenever traffic transmitted by the local device over a link is received by the neighbor but traffic transmitted from the neighbor is not received by the local device. For example, if one of the fiber strands in a pair is disconnected, as long as autonegotiation is active the link does not stay up. In this situation, the logical link is undetermined, and UDLD does not take any actions. If both fibers are working normally at Layer 1, then UDLD at Layer 2 determines whether those fibers are connected correctly and whether traffic is flowing bidirectionally between the correct neighbors. This check cannot be performed by autonegotiation, because autonegotiation is a Layer 1 feature.

The switch periodically transmits UDLD messages (packets) to neighbor devices on ports with UDLD enabled. If the messages are echoed back to the sender within a specific time frame and they are lacking a specific acknowledgment (echo), the link is flagged as unidirectional and the port is shut down. Devices on both ends of the link must support UDLD in order for the protocol to successfully identify and disable unidirectional links.

**Note**

With supervisor engine software release 5.4(3) and later, you can specify the message interval between UDLD messages. Previously, the message interval was fixed at 60 seconds. With a configurable message interval, UDLD reacts much faster to link failures.

Figure 24-1 shows an example of a unidirectional link condition. Switch B successfully receives traffic from Switch A on the port. However, Switch A does not receive traffic from Switch B on the same port. UDLD detects the problem and disables the port.

**Figure 24-1 Unidirectional Link**

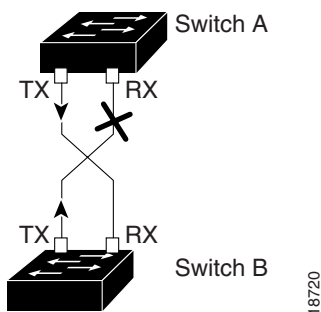

## UDLD Software and Hardware Requirements

UDLD requires the following hardware and software:

- For fiber-optic links:
  - Supervisor engine software release 5.1 or later
  - Ethernet, Fast Ethernet, or Gigabit Ethernet fiber-optic switching modules
- For copper links:
  - Supervisor engine software release 5.2 or later
  - Ethernet or Fast Ethernet copper switching modules

# Default UDLD Configuration

Table 24-1 shows the default UDLD configuration.

**Table 24-1 UDLD Default Configuration**

Feature	Default Value
UDLD global enable state	Globally disabled
UDLD per-port enable state	<ul style="list-style-type: none"> <li>Enabled on all Ethernet, Fast Ethernet, and Gigabit Ethernet ports using fiber-optic media</li> <li>Disabled on all Ethernet and Fast Ethernet ports using copper media</li> </ul>
UDLD message interval	15 seconds
UDLD aggressive mode	Disabled

## Configuring UDLD

These sections describe how to configure UDLD:

- [Enabling UDLD Globally, page 24-3](#)
- [Enabling UDLD on Individual Ports, page 24-4](#)
- [Disabling UDLD on Individual Ports, page 24-4](#)
- [Disabling UDLD Globally, page 24-4](#)
- [Specifying the UDLD Message Interval, page 24-5](#)
- [Enabling UDLD Aggressive Mode, page 24-5](#)
- [Displaying the UDLD Configuration, page 24-6](#)

## Enabling UDLD Globally

You must enable UDLD globally before any port can use UDLD.

To enable UDLD globally on the switch, perform this task in privileged mode:

	Task	Command
<b>Step 1</b>	Enable UDLD globally on the switch.	<b>set udld enable</b>
<b>Step 2</b>	Verify the configuration.	<b>show udld</b>

This example shows how to enable UDLD globally and verify the configuration:

```

Console> (enable) set udld enable
UDLD enabled globally
Console> (enable) show udld
UDLD      : enabled
Console> (enable)

```

## Enabling UDLD on Individual Ports

To enable UDLD on individual ports, perform this task in privileged mode:

	Task	Command
Step 1	Enable UDLD on a specific port.	<b>set udld enable</b> <i>mod/port</i>
Step 2	Verify the configuration.	<b>show udld port</b> [ <i>mod[/port]</i> ]

This example shows how to enable UDLD on port 4/1 and verify the configuration:

```

Console> (enable) set udld enable 4/1
UDLD enabled on port 4/1
Console> (enable) show udld port 4/1
UDLD      : enabled
Message Interval: 15 seconds
Port      Admin Status  Aggressive Mode  Link State
-----  -
4/1      enabled          disabled         bidirectional
Console> (enable)

```

## Disabling UDLD on Individual Ports

To disable UDLD on individual ports, perform this task in privileged mode:

	Task	Command
Step 1	Disable UDLD on a specific port.	<b>set udld disable</b> <i>mod/port</i>
Step 2	Verify the configuration.	<b>show udld port</b> [ <i>mod[/port]</i> ]

This example shows how to disable UDLD on port 4/1:

```

Console> (enable) set udld disable 4/1
UDLD disabled on port 4/1.
Console> (enable)

```

## Disabling UDLD Globally

To disable UDLD globally on the switch, perform this task in privileged mode:

	Task	Command
Step 1	Disable UDLD globally on the switch.	<b>set udld disable</b>
Step 2	Verify the configuration.	<b>show udld</b>

This example shows how to disable UDLD globally on the switch:

```

Console> (enable) set udld disable
UDLD disabled globally
Console> (enable)

```

## Specifying the UDLD Message Interval

To specify the UDLD message interval, perform this task in privileged mode:

	Task	Command
Step 1	Specify the UDLD message interval.	<b>set udld interval</b> <i>interval</i>
Step 2	Verify the configuration.	<b>show udld</b>

This example shows how to specify the UDLD message interval on the switch:

```
Console> (enable) set udld interval 10
UDLD message interval set to 10 seconds
Console> (enable)
```

This example shows how to verify the message interval on the switch:

```
Console> (enable) show udld
UDLD                : enabled
Message Interval    : 10 seconds
Console> (enable)
```

## Enabling UDLD Aggressive Mode

Software releases 5.4(3) and later include UDLD aggressive mode. UDLD aggressive mode is disabled by default and its use is recommended only for point-to-point links between Cisco switches running software release 5.4(3) or later. With aggressive mode enabled, when a port on a bidirectional link stops receiving UDLD packets, UDLD tries to reestablish the connection with the neighbor. After eight failed retries, the port is put into errdisable state.

In order to prevent spanning tree loops, normal UDLD with a message interval of 15 seconds is fast enough to shut down a unidirectional link before a blocking port transitions to forwarding state (when default spanning tree parameters are used).

UDLD aggressive mode provides additional benefits in the following situations:

- One side of a link has a port stuck (both tx and rx)
- One side of a link remains up while the other side of the link has gone down

In these situations, UDLD aggressive mode error disables one of the ports on the link and stops the blackholing of traffic. Even with aggressive mode disabled, there is no risk for a broadcast storm due to a spanning tree loop in this situation because one port cannot pass traffic in both directions.

We recommend that you do not use UDLD or aggressive UDLD with the ON AUTO trunk combination. UDLD and aggressive UDLD can be used with any other valid trunk combination.

To enable UDLD aggressive mode on module ports, perform this task in privileged mode:

	Task	Command
Step 1	Enable UDLD aggressive mode.	<b>set udld aggressive-mode enable</b> <i>mod/port</i>
Step 2	Verify the configuration.	<b>show udld</b>

This example shows how to enable UDLD aggressive mode on the switch:

```
Console> (enable) set udld aggressive-mode enable 4/1
Aggressive UDLD enabled on port 4/1.
Console> (enable)
```

This example shows how to verify that UDLD aggressive mode is enabled on the switch:

```
Console> (enable) show udld port 4/1
UDLD          : enabled
Message Interval: 10 seconds
Port      Admin Status  Aggressive Mode  Link State
-----  -
4/1      enabled        Enabled          bidirectional
Console> (enable)
```

## Displaying the UDLD Configuration

To display the UDLD enable state, perform this task in privileged mode:

Task	Command
Display the UDLD enable state.	<b>show udld</b>

This example shows how to display the UDLD enable state:

```
Console> (enable) show udld
UDLD          : enabled
Message Interval : 10 seconds
Console> (enable)
```

To display UDLD configuration for a module or port, perform this task in privileged mode:

Task	Command
Display the UDLD configuration for a module or port.	<b>show udld port [mod] [mod/port]</b>

This example shows how to display the UDLD configuration for ports on module 4:

```
Console> (enable) show udld port 4
UDLD          : enabled
Message Interval: 10 seconds
Port      Admin Status  Aggressive Mode  Link State
-----  -
4/1      enabled        disabled         bidirectional
4/2      enabled        disabled         bidirectional
4/3      enabled        disabled         undetermined
4/4      enabled        disabled         bidirectional
.
.
Console> (enable)
```

Table 24-2 describes the fields in the **show udld** command output.

**Table 24-2** *show udld Command Output Fields*

Field	Description
UDLD	Status of whether UDLD is enabled or disabled.
Message Interval	Message interval in seconds.
Port	Module and port numbers.
Admin Status	Status of whether administration status is enabled or disabled.
Aggressive Mode	Status of whether aggressive mode is enabled or disabled.
Link State	Status of the link: undetermined (detection in progress, neighboring UDLD has been disabled), not applicable (UDLD has been disabled), shutdown (unidirectional link has been detected and the port disabled), or bidirectional (bidirectional link has been detected and the port disabled).

