

Configuring InterVLAN Routing

This chapter describes how to configure switches and routers for inter-virtual LAN (VLAN) routing. The configuration procedures and examples in this chapter are designed as a starting point to help you configure interVLAN routing for your network environment.

Note For complete syntax and usage information for the IOS commands used in this chapter, refer to the software documentation for your router platform. For complete syntax and usage information for the switch commands used in this chapter, refer to the *Command Reference* for your switch.

These sections describe how to configure interVLAN routing:

- Understanding How InterVLAN Routing Works on page 39-1
- Configuring VTP and VLANs on the Switch on page 39-3
- Basic Router Configuration Tasks on page 39-4
- Configuring InterVLAN Routing on the RSM on page 39-5
- Configuring InterVLAN Routing on an External Cisco Router on page 39-7
- Configuring InterVLAN Routing on the Catalyst 8510 CSR on page 39-10
- InterVLAN Routing Configuration Examples on page 39-13

Understanding How InterVLAN Routing Works

Network devices in different VLANs cannot communicate with one another without a router to route traffic between the VLANs. In most network environments, VLANs are associated with individual networks or subnetworks.

For example, in an IP network, each subnetwork is mapped to an individual VLAN. In an IPX network, each VLAN is mapped to an IPX network number. In an AppleTalk network, each VLAN is associated with a cable range and AppleTalk zone name.

Configuring VLANs helps control the size of the broadcast domain and keeps local traffic local. However, when an end station in one VLAN needs to communicate with an end station in another VLAN, interVLAN communication is required. This communication is supported by interVLAN routing. You configure one or more routers to route traffic to the appropriate destination VLAN.

Figure 39-1 shows a basic interVLAN routing topology. Switch A is in VLAN 10 and Switch B is in VLAN 20. The router has an interface in each VLAN.

Figure 39-1 Basic InterVLAN Routing Topology

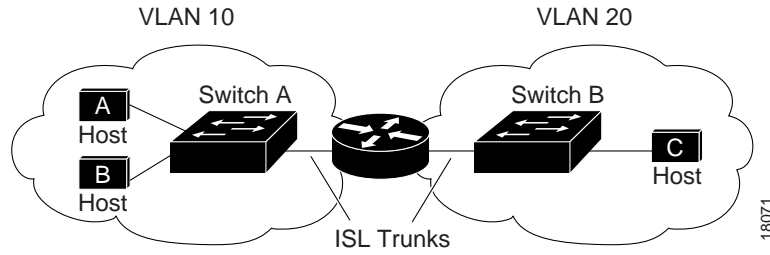

When Host A in VLAN 10 needs to communicate with Host B in VLAN 10, it sends a packet addressed to that host. Switch A forwards the packet directly to Host B, without sending it to the router.

When Host A sends a packet to Host C in VLAN 20, Switch A forwards the packet to the router, which receives the traffic on the VLAN 10 interface. The router checks the routing table, determines the correct outgoing interface, and forwards the packet out the VLAN 20 interface to Switch B. Switch B receives the packet and forwards it to Host C.

Figure 39-2 shows another common scenario, interVLAN routing over a single trunk connection to the router. The switch has ports in multiple VLANs. InterVLAN routing is performed by a Cisco 7505 router connected to the switch through a full-duplex Fast Ethernet trunk link.

Figure 39-2 InterVLAN Routing Over a Single Trunk Link

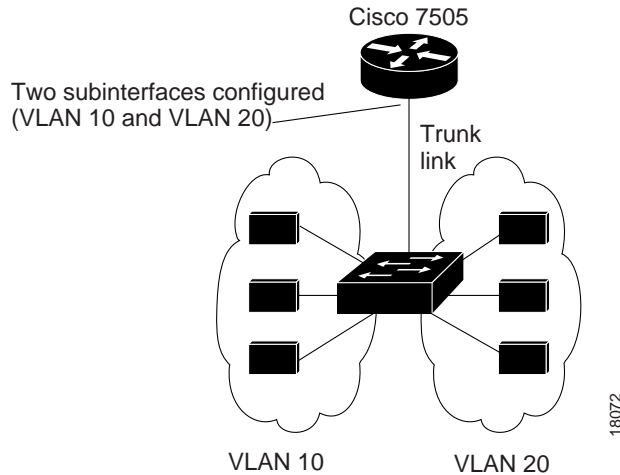

Multiple subinterfaces are configured on the physical Fast Ethernet router interface, one for each VLAN supported on the trunk. IntraVLAN traffic (traffic with the source and destination host in the same VLAN) is handled entirely by the switch.

InterVLAN traffic is sent across the trunk to the router. The router checks the routing table, determines the outgoing subinterface (destination VLAN), and sends the traffic back over the trunk to the switch, where it is forwarded out the appropriate switch port.

Configuring VTP and VLANs on the Switch

In order to successfully configure a router for interVLAN routing, you must configure VTP and create and configure VLANs on the switch.

Note This section describes the basics of VTP and VLAN configuration. For detailed information on configuring VTP, see Chapter 9, “Configuring VTP.” For detailed information on configuring VLANs, see Chapter 10, “Configuring VLANs.”

To configure VTP and VLANs on the switch, perform this task in privileged mode:

Task	Command
Step 1 Specify the VTP mode.	set vtp mode {client server transparent }
Step 2 Configure a VTP domain (if you configured the switch as a VTP client or server).	set vtp domain name
Step 3 Create VLANs on the switch.	set vlan vlan_num
Step 4 Assign ports to the VLAN.	set vlan vlan_num mod_num/port_num

This example shows how to configure VTP, create two VLANs, and assign switch ports to those VLANs:

```

Console> (enable) set vtp mode server
VTP domain modified
Console> (enable) set vtp domain Corp_Net
VTP domain Corp_Net modified
Console> (enable) set vlan 100
Vlan 100 configuration successful
Console> (enable) set vlan 200
Vlan 200 configuration successful
Console> (enable) set vlan 100 3/1-12
VLAN 100 modified.
VLAN 1 modified.
VLAN Mod/Ports
-----
100  1/1-2
     3/1-12

Console> (enable) set vlan 200 3/13-24
VLAN 200 modified.
VLAN 1 modified.
VLAN Mod/Ports
-----
200  1/1-2
     3/13-24

Console> (enable)

```

Basic Router Configuration Tasks

These sections describe basic router configuration tasks you need to understand before you configure interVLAN routing:

- Accessing Configuration Mode on the Router on page 39-4
- Viewing and Saving the Router Configuration on page 39-4
- Bringing Up a Router Interface on page 39-4

Accessing Configuration Mode on the Router

To access configuration mode on the router, perform this task:

Task	Command
Step 1 At the EXEC prompt, enter enable mode.	Router> enable
Step 2 At the privileged EXEC prompt, enter global configuration mode.	Router# configure terminal
Step 3 Enter the commands to configure interVLAN routing.	(Refer to the appropriate configuration tasks later in this chapter.)
Step 4 Exit configuration mode.	Router(config)# Ctrl-Z

Viewing and Saving the Router Configuration

To view and save the configuration after you make changes, perform this task:

Task	Command
Step 1 View the current operating configuration at the privileged EXEC prompt.	Router# show running-config
Step 2 View the configuration in NVRAM.	Router# show startup-config
Step 3 Save the current configuration to NVRAM.	Router# copy running-config startup-config

Bringing Up a Router Interface

In some cases, a router interface might be administratively shut down. You can check the status of an interface using the **show interface** command.

To bring up a router interface that is administratively shut down, perform this task in privileged mode:

Task	Command
Step 1 Specify the interface to bring up.	Router(config)# interface <i>interface_type</i> <i>interface_number</i>
Step 2 Bring the interface up.	Router(config-if)# no shutdown
Step 3 Exit configuration mode.	Router(config-if)# Ctrl-Z

Configuring InterVLAN Routing on the RSM

Note This section is for those who are familiar with Cisco IOS software and have some experience configuring Cisco routers. If you are not familiar with configuring Cisco routers, refer to the documentation for your router platform.

These sections describe how to configure interVLAN routing on the Catalyst 5000 series RSM:

- RSM Configuration Guidelines on page 39-5
- Accessing the RSM from the Switch on page 39-5
- Configuring IP InterVLAN Routing on the RSM on page 39-6
- Configuring IPX InterVLAN Routing on the RSM on page 39-6
- Configuring AppleTalk InterVLAN Routing on the RSM on page 39-7

Note For a detailed configuration example of IP interVLAN routing, see the “InterVLAN Routing with the RSM Example” section on page 39-13.

RSM Configuration Guidelines

Configuring interVLAN routing on the RSM consists of two main procedures:

- 1 You must create and configure VLANs on the switch and assign VLAN membership to switch ports. For more information, see the “Configuring VTP and VLANs on the Switch” section on page 39-3.
- 2 You must create and configure VLAN interfaces for interVLAN routing on the RSM. You must configure a VLAN interface for each VLAN between which you want to route traffic.

VLAN interfaces on the RSM are virtual interfaces. However, you configure them much as you do a physical router interface. If you have the optional VIP2 module, you can route traffic between VLAN interfaces and physical interfaces on port adapters installed in the VIP2.

Accessing the RSM from the Switch

You can use the **session** *mod_num* command (where *mod_num* is slot in which the RSM is installed) to access the RSM from the switch CLI, eliminating the need to connect a terminal directly to the RSM console port. To exit from the router CLI back to the switch CLI, enter **exit** at the Router> prompt.

This example shows how to access the RSM from the switch CLI, and how to exit the router CLI and return to the switch CLI:

```
Console> (enable) session 5
Trying Router-5...
Connected to Router-5.
Escape character is '^]'.

User Access Verification

Password:
Router>exit
Console> (enable)
```

Configuring IP InterVLAN Routing on the RSM

To configure interVLAN routing for IP, perform this task:

Task	Command
Step 1 (Optional) Enable IP routing on the router ¹ .	Router(config)# ip routing
Step 2 (Optional) Specify an IP routing protocol ² .	Router(config)# router <i>ip_routing_protocol</i>
Step 3 Specify a VLAN interface on the RSM.	Router(config)# interface <i>vlan-id</i>
Step 4 Assign an IP address to the VLAN.	Router(config-if)# ip address <i>n.n.n.n mask</i>
Step 5 Exit configuration mode.	Router(config-if)# Ctrl-Z

- 1 This step is necessary if you have multiple routers in the network.
- 2 This step is necessary if you enabled IP routing in Step 1. This step might include other commands, such as specifying the networks to route for using the **network** router configuration command. Refer to the documentation for your router platform for detailed information on configuring routing protocols.

This example shows how to enable IP routing on the RSM, create a VLAN interface, and assign the interface an IP address:

```
Router#configure terminal
Enter configuration commands, one per line. End with CNTL/Z.
Router(config)#ip routing
Router(config)#router rip
Router(config-router)#network 10.0.0.0
Router(config-router)#interface vlan 100
Router(config-if)#ip address 10.1.1.1 255.0.0.0
Router(config-if)#^Z
Router#
```

Configuring IPX InterVLAN Routing on the RSM

To configure interVLAN routing for Internetwork Packet Exchange (IPX), perform this task:

Task	Command
Step 1 (Optional) Enable IPX routing on the router ¹ .	Router(config)# ipx routing
Step 2 (Optional) Specify an IPX routing protocol ² .	Router(config)# ipx router <i>ipx_routing_protocol</i>
Step 3 Specify a VLAN interface on the RSM.	Router(config)# interface <i>vlan-id</i>
Step 4 Assign a network number to the VLAN ³ .	Router(config-if)# ipx network [<i>network</i> unnumbered] encapsulation <i>encapsulation-type</i>
Step 5 Exit configuration mode.	Router(config-if)# Ctrl-Z

- 1 This step is necessary if you have multiple routers in the network.
- 2 This step is necessary if you enabled IPX routing in Step 1. This step might include other commands, such as specifying the networks to route for using the **network** router configuration command. Refer to the documentation for your router platform for detailed information on configuring routing protocols.
- 3 This enables IPX routing on the VLAN. When you enable IPX routing on the VLAN, you can also specify an encapsulation type.

This example shows how to enable IPX routing on the RSM, create a VLAN interface, and assign the interface an IPX network address:

```
Router#configure terminal
Enter configuration commands, one per line. End with CNTL/Z.
Router(config)#ipx routing
Router(config)#ipx router rip
Router(config-ipx-router)#network all
Router(config-ipx-router)#interface vlan100
Router(config-if)#ipx network 100 encapsulation snap
Router(config-if)#^Z
Router#
```

Configuring AppleTalk InterVLAN Routing on the RSM

To configure interVLAN routing for AppleTalk, perform this task:

Task	Command
Step 1 (Optional) Enable AppleTalk routing on the router ¹ .	Router(config)# appletalk routing
Step 2 Specify a VLAN interface on the RSM.	Router(config)# interface vlan-id
Step 3 Assign a cable range to the VLAN.	Router(config-if)# appletalk cable-range cable-range
Step 4 Assign a zone name to the VLAN.	Router(config-if)# appletalk zone zone-name
Step 5 Exit configuration mode.	Router(config-if)# Ctrl-Z

¹ This step is necessary if you have multiple routers in the network.

This example shows how to enable AppleTalk routing on the RSM, create a VLAN interface, and assign the interface an AppleTalk cable-range and zone name:

```
Router#configure terminal
Enter configuration commands, one per line. End with CNTL/Z.
Router(config)#appletalk routing
Router(config)#interface vlan100
Router(config-if)#appletalk cable-range 100-100
Router(config-if)#appletalk zone Engineering
Router(config-if)#^Z
Router#
```

Configuring InterVLAN Routing on an External Cisco Router

Note This section is for those who are familiar with Cisco IOS software and have some experience configuring Cisco routers. If you are not familiar with configuring Cisco routers, refer to the Cisco IOS Configuration Guides and Command References.

To configure interVLAN routing on an external Cisco router, access the router CLI through the console port or a Telnet connection.

These sections describe how to configure interVLAN routing on an external Cisco router:

- Configuring IP InterVLAN Routing on an External Router on page 39-8
- Configuring IPX InterVLAN Routing on an External Router on page 39-9
- Configuring AppleTalk InterVLAN Routing on an External Router on page 39-9

Note For a detailed configuration example of IP interVLAN routing with an external Cisco router, see the “InterVLAN Routing with an External Cisco 7505 Router Example” section on page 39-17.

Configuring IP InterVLAN Routing on an External Router

To configure interVLAN routing for IP, perform this task:

Task	Command
Step 1 (Optional) Enable IP routing on the router ¹ .	Router(config)# ip routing
Step 2 (Optional) Specify an IP routing protocol ² .	Router(config)# router <i>ip_routing_protocol</i>
Step 3 Create a subinterface on a physical interface.	Router(config)# interface <i>interface_type</i> <i>interface_number.subinterface_number</i>
Step 4 Specify the encapsulation and VLAN number to use on the subinterface.	Router(config-subif)# encapsulation <i>encapsulation_type</i> <i>vlan_id</i>
Step 5 Assign an IP address to the subinterface.	Router(config-subif)# ip address <i>n.n.n.n mask</i>
Step 6 Repeat Steps 3–5 for each VLAN between which you want to route traffic.	
Step 7 Exit configuration mode.	Router(config-subif)# Ctrl-Z

1 This step is necessary if you have multiple routers in the network.

2 This step is necessary if you enabled IP routing in Step 1. This step might include other commands, such as specifying the networks to route for using the **network** router configuration command. Refer to the documentation for your router platform for detailed information on configuring routing protocols.

This example shows how to enable IP routing on the router, create two subinterfaces, and specify the encapsulation, VLAN number, and IP address for each subinterface:

```
Cisco7505#configure terminal
Enter configuration commands, one per line. End with CNTL/Z.
Cisco7505 (config)#ip routing
Cisco7505 (config)#router rip
Cisco7505 (config-router)#network 10.0.0.0
Cisco7505 (config-router)#interface fastethernet2/0.100
Cisco7505 (config-subif)#encapsulation isl 100
Cisco7505 (config-subif)#ip address 10.10.1.1 255.255.0.0
Cisco7505 (config-router)#interface fastethernet2/0.200
Cisco7505 (config-subif)#encapsulation isl 200
Cisco7505 (config-subif)#ip address 10.20.1.1 255.255.0.0
Cisco7505 (config-subif)#^Z
Cisco7505#
```

Configuring IPX InterVLAN Routing on an External Router

To configure interVLAN routing for IPX, perform this task:

Task	Command
Step 1 (Optional) Enable IPX routing on the router ¹ .	Router(config)# ipx routing
Step 2 (Optional) Specify an IPX routing protocol ² .	Router(config)# ipx router <i>ipx_routing_protocol</i>
Step 3 Create a subinterface on a physical interface.	Router(config)# interface <i>interface_type</i> <i>interface_number.subinterface_number</i>
Step 4 Specify the encapsulation and VLAN number to use on the subinterface.	Router(config-subif)# encapsulation <i>encapsulation_type</i> <i>vlan_id</i>
Step 5 Assign a network number to the VLAN ³ .	Router(config-subif)# ipx network [<i>network</i> unnumbered] encapsulation <i>encapsulation-type</i>
Step 6 Repeat Steps 3–5 for each VLAN between which you want to route traffic.	
Step 7 Exit configuration mode.	Router(config-subif)# Ctrl-Z

1 This step is necessary if you have multiple routers in the network.

2 This step is necessary if you enabled IPX routing in Step 1. This step might include other commands, such as specifying the networks to route for using the **network** router configuration command. Refer to the documentation for your router platform for detailed information on configuring routing protocols.

3 This enables IPX routing on the VLAN. When you enable IPX routing on the subinterface, you can also specify an encapsulation type.

This example shows how to enable IPX routing on the router, create two subinterfaces, and specify the encapsulation, VLAN number, and IPX network address for each subinterface:

```
Cisco7505#configure terminal
Enter configuration commands, one per line. End with CNTL/Z.
Cisco7505 (config) #ipx routing
Cisco7505 (config) #ipx router rip
Cisco7505 (config-ipx-router) #network all
Cisco7505 (config-ipx-router) #interface fastethernet2/0.100
Cisco7505 (config-subif) #encapsulation isl 100
Cisco7505 (config-subif) #ipx network 100 encapsulation snap
Cisco7505 (config-subif) #interface fastethernet2/0.200
Cisco7505 (config-subif) #encapsulation isl 200
Cisco7505 (config-subif) #ipx network 200 encapsulation snap
Cisco7505 (config-subif) #^Z
Cisco7505#
```

Configuring AppleTalk InterVLAN Routing on an External Router

To configure interVLAN routing for AppleTalk, perform this task:

Task	Command
Step 1 (Optional) Enable AppleTalk routing on the router ¹ .	Router(config)# appletalk routing
Step 2 Create a subinterface on a physical interface.	Router(config)# interface <i>interface_type</i> <i>interface_number.subinterface_number</i>
Step 3 Specify the encapsulation and VLAN number to use on the subinterface.	Router(config-subif)# encapsulation <i>encapsulation_type</i> <i>vlan_id</i>
Step 4 Assign a cable range to the VLAN.	Router(config-subif)# appletalk cable-range <i>cable-range</i>
Step 5 Assign a zone name to the VLAN.	Router(config-subif)# appletalk zone <i>zone-name</i>

Task	Command
Step 6 Repeat Steps 2–5 for each VLAN between which you want to route traffic.	
Step 7 Exit configuration mode.	Router(config-subif)# Ctrl-Z

1 This step is necessary if you have multiple routers in the network.

Configuring InterVLAN Routing on the Catalyst 8510 CSR

Note This section does not describe a full configuration for the Catalyst 8510 CSR. In many cases, you must configure additional interfaces, routing protocols, and other features on the switch before it is fully functional. For complete information on configuring the Catalyst 8510 CSR, refer to the documentation provided with your router.

To configure interVLAN routing on the Catalyst 8510 CSR, access the Catalyst 8510 CSR CLI through the console port or a Telnet connection.

These sections describe how to configure interVLAN routing on the Catalyst 8510 CSR:

- (Optional) Creating and Grouping Ports to a Port-Channel Interface on page 39-10
- Configuring Subinterfaces for IP InterVLAN Routing on page 39-11

Note For a detailed configuration example of IP interVLAN routing using the Catalyst 8510 CSR, see the “InterVLAN Routing with an External Catalyst 8510 CSR Example” section on page 39-19.

Creating and Grouping Ports to a Port-Channel Interface

A port-channel interface is a logical interface into which you group physical interfaces to form a single logical link.

Note Configure a port-channel interface on the Catalyst 8510 CSR only if you plan to connect to a switch through a Fast or Gigabit EtherChannel port bundle.

If you plan to use an EtherChannel port bundle to connect the devices, you must configure a port-channel interface, group physical interfaces to the port-channel interface, and configure subinterfaces on the port-channel interface, one for each VLAN for which you want to route traffic.

To create a port-channel interface and group physical interfaces to it, perform this task:

Task	Command
Step 1 Create a port-channel interface.	interface port-channel <i>interface_number</i>
Step 2 Enter interface configuration mode for each physical interface you want to group to the port-channel interface.	interface <i>interface_type slot/0/interface</i>
Step 3 Associate the interface with the port-channel interface you created.	channel-group <i>port_channel_interface_number</i>
Step 4 Exit configuration mode.	^Z

This example shows how to create a port-channel interface on the Catalyst 8510 CSR and how to group interfaces to the port-channel interface:

```
Switch>enable
Switch#configure terminal
Enter configuration commands, one per line. End with CNTL/Z.
Switch(config)#interface port-channel 1
Switch(config-if)#interface fastethernet0/0/0
Switch(config-if)#channel-group 1

FastEthernet0/0/0 added as member-0 to port-channel1
Switch(config-if)#interface fastethernet0/0/1
Switch(config-if)#channel-group 1

FastEthernet0/0/1 added as member-1 to port-channel1
Switch(config-if)#^Z
Switch#
```

Configuring Subinterfaces for IP InterVLAN Routing

InterVLAN routing is achieved by configuring subinterfaces on a physical or virtual interface. If the connection to the Layer 2 switch is through a single interface, configure the subinterfaces on the physical interface. If the connection to the Layer 2 switch is through a port-channel interface, configure the subinterfaces on the port-channel interface.

Note For more information about configuring port-channel interfaces, see “Creating and Grouping Ports to a Port-Channel Interface” section on page 39-10.

Configure one subinterface for each VLAN between which you want to route traffic.

To configure interVLAN routing on a Catalyst 8510 CSR interface, perform this task: This example

Task	Command
Step 1 (Optional) Enable IP routing ¹ .	ip routing
Step 2 (Optional) Specify an IP routing protocol ² .	router <i>ip_routing_protocol</i>
Step 3 Create a subinterface on a physical or port-channel interface.	interface <i>interface_type interface.subinterface</i>
Step 4 Specify the interface encapsulation and VLAN number on the subinterface (this VLAN typically exists already on the connected Layer 2 switch).	encapsulation <i>encapsulation vlan_id</i>
Step 5 Assign an IP address and subnet mask to the subinterface.	ip address <i>ip_addr subnet_mask</i>

Task	Command
Step 6 Repeat Steps 2–4 to create and configure additional subinterfaces on the physical or port-channel interface. Configure one subinterface for each VLAN for which you want to route traffic.	
Step 7 Exit configuration mode.	^Z
1 This step is necessary if you have multiple routers in the network.	
2 This step is necessary if you enabled IP routing in Step 1. This step might include other commands, such as specifying the networks to route for using the network router configuration command. Refer to the documentation for your router platform for detailed information on configuring routing protocols.	

shows how to create three subinterfaces on a port-channel interface and configure them for interVLAN routing (VLANs 1, 2, and 3):

```
Switch#configure terminal
Enter configuration commands, one per line. End with CNTL/Z.
Switch(config)#interface port-channel 1.1
Switch(config-subif)#encapsulation isl 1
Switch(config-subif)#ip address 172.20.50.33 255.255.255.224
Switch(config-subif)#interface port-channel 1.2
Switch(config-subif)#encapsulation isl 2
Switch(config-subif)#ip address 172.20.50.65 255.255.255.224
Switch(config-subif)#interface port-channel 1.3
Switch(config-subif)#encapsulation isl 3
Switch(config-subif)#ip address 172.20.50.97 255.255.255.224
Switch(config-subif)#^Z
Switch#
```

InterVLAN Routing Configuration Examples

These sections contain interVLAN routing configuration examples:

- InterVLAN Routing with the RSM Example on page 39-13
- InterVLAN Routing with an External Cisco 7505 Router Example on page 39-17
- InterVLAN Routing with an External Catalyst 8510 CSR Example on page 39-19

InterVLAN Routing with the RSM Example

Figure 39-3 shows the network configuration for this example. There are three switches, one with an RSM installed in slot 5. The switches are connected through the Fast Ethernet uplink ports on the supervisor engines. Each switch has a 10/100-Mbps Fast Ethernet module in slot 3. Three hosts are connected to each switch, on ports 3/1, 3/2, and 3/3.

Figure 39-3 InterVLAN Routing with the RSM Example Configuration

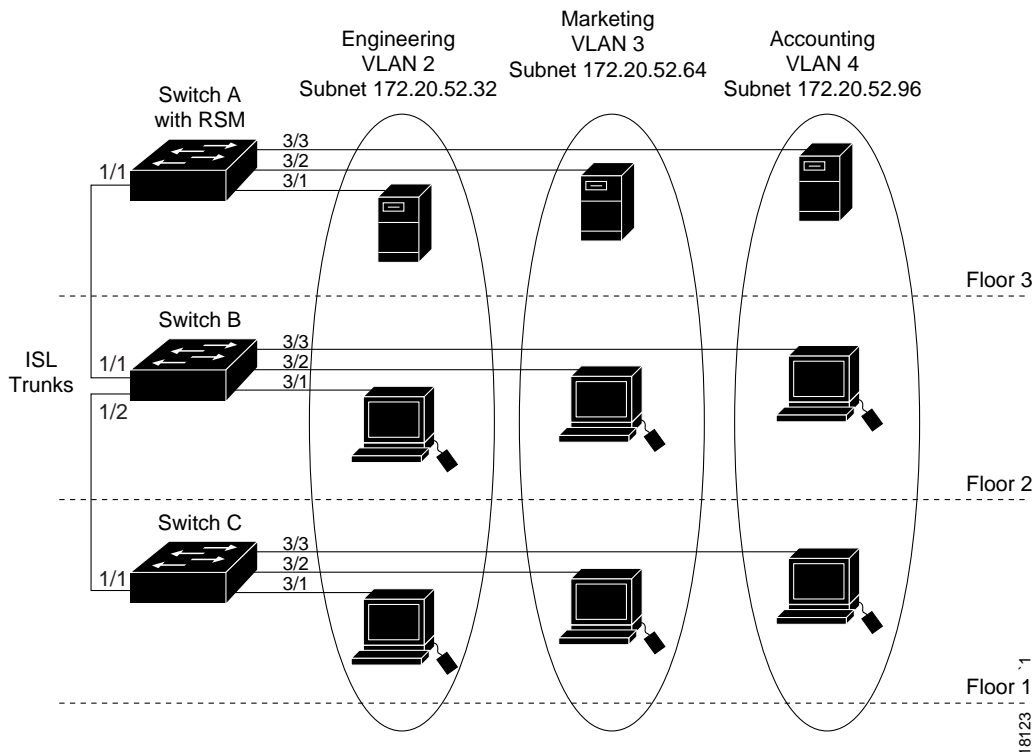

These configuration tasks must be performed to configure the network in this example:

- 1 Configure Switch A as a VTP server and assign a VTP domain name.
- 2 Configure Switch B and Switch C as VTP clients and assign the same VTP domain name.
- 3 Configure ISL trunk links between the switches.
- 4 Create the VLANs on Switch A (the VLAN information is propagated to Switch B and Switch C through VTP).
- 5 Assign the switch ports on each switch to the appropriate VLAN.
- 6 On the RSM, create one VLAN interface for each VLAN configured on Switch A.
- 7 Assign IP addresses to the VLAN interfaces.

After you successfully configure the network, all end stations should be able to communicate with one another. Communication between hosts in the same VLAN is handled only by the switches. All interVLAN traffic must be routed by the RSM.

For example, if the VLAN 2 host on Floor 1 needs to communicate with the VLAN 3 host on Floor 1, the traffic must travel through all three switches to reach the RSM, where it is routed and sent back through all three switches to the destination host.

Switch A Configuration

This example shows how to configure Switch A:

```
SwitchA> (enable) set trunk 1/1 desirable
Port(s) 1/1 trunk mode set to desirable.
SwitchA> (enable) %DTP-5-TRUNKPORTON:Port 1/1 has become isl trunk
%PAGP-5-PORTTOSTP:Port 1/1 joined bridge port 1/1
%PAGP-5-PORTFROMSTP:Port 1/1 left bridge port 1/1
%PAGP-5-PORTTOSTP:Port 1/1 joined bridge port 1/1

SwitchA> (enable) set vtp domain Corporate
VTP domain Corporate modified
SwitchA> (enable) set vtp mode server
VTP domain Corporate modified
SwitchA> (enable) set vlan 2 name Engineering
Vlan 2 configuration successful
SwitchA> (enable) set vlan 3 name Marketing
Vlan 3 configuration successful
SwitchA> (enable) set vlan 4 name Accounting
Vlan 4 configuration successful
SwitchA> (enable) set vlan 2 3/1
VLAN 2 modified.
VLAN 1 modified.
VLAN Mod/Ports
-----
2      3/1

SwitchA> (enable) set vlan 3 3/2
VLAN 3 modified.
VLAN 1 modified.
VLAN Mod/Ports
-----
3      3/2

SwitchA> (enable) set vlan 4 3/3
VLAN 4 modified.
VLAN 1 modified.
VLAN Mod/Ports
-----
4      3/3

SwitchA> (enable)
```

Switch B Configuration

This example shows how to configure Switch B:

```
SwitchB> (enable) set trunk 1/2 desirable
Port(s) 1/2 trunk mode set to desirable.
SwitchB> (enable) %DTP-5-TRUNKPORTON:Port 1/2 has become isl trunk
%PAGP-5-PORTTOSTP:Port 1/2 joined bridge port 1/2
%PAGP-5-PORTFROMSTP:Port 1/2 left bridge port 1/2
%PAGP-5-PORTTOSTP:Port 1/2 joined bridge port 1/2

SwitchB> (enable) set vtp domain Corporate
VTP domain Corporate modified
SwitchB> (enable) set vtp mode client
VTP domain Corporate modified
SwitchB> (enable) set vlan 2 3/1
VLAN 2 modified.
VLAN 1 modified.
VLAN Mod/Ports
-----
2      3/1
```

```
SwitchB> (enable) set vlan 3 3/2
Vlan 3 configuration successful
VLAN 3 modified.
VLAN 1 modified.
VLAN Mod/Ports
-----
3      3/2
```

```
SwitchB> (enable) set vlan 4 3/3
Vlan 4 configuration successful
VLAN 4 modified.
VLAN 1 modified.
VLAN Mod/Ports
-----
4      3/3
```

```
SwitchB> (enable)
```

Switch C Configuration

This example shows how to configure Switch C:

```
SwitchB> (enable) set vtp domain Corporate
VTP domain Corporate modified
SwitchB> (enable) set vtp mode client
VTP domain Corporate modified
SwitchB> (enable) set vlan 2 3/1
VLAN 2 modified.
VLAN 1 modified.
VLAN Mod/Ports
-----
2      3/1
```

```
SwitchB> (enable) set vlan 3 3/2
Vlan 3 configuration successful
VLAN 3 modified.
VLAN 1 modified.
VLAN Mod/Ports
-----
3      3/2
```

```
SwitchB> (enable) set vlan 4 3/3
Vlan 4 configuration successful
VLAN 4 modified.
VLAN 1 modified.
VLAN Mod/Ports
-----
4      3/3
```

```
SwitchB> (enable)
```

RSM Configuration

This example shows how to configure the RSM:

```
SwitchA> (enable) session 5
Trying Router-5...
Connected to Router-5.
Escape character is '^]'.

Router>enable
Router#configure terminal
Enter configuration commands, one per line.  End with CNTL/Z.
Router(config)#interface vlan 2
Router(config-if)#
%LINEPROTO-5-UPDOWN: Line protocol on Interface Vlan2, changed state to down
Router(config-if)#ip address 172.20.52.33 255.255.255.224
Router(config-if)#no shutdown
%LINEPROTO-5-UPDOWN: Line protocol on Interface Vlan2, changed state to up
Router(config-if)#interface vlan 3
Router(config-if)#
%LINEPROTO-5-UPDOWN: Line protocol on Interface Vlan3, changed state to down
Router(config-if)#ip address 172.20.52.65 255.255.255.224
Router(config-if)#no shutdown
Router(config-if)#
%LINEPROTO-5-UPDOWN: Line protocol on Interface Vlan3, changed state to up
Router(config-if)#
%LINK-3-UPDOWN: Interface Vlan3, changed state to up
Router(config-if)#interface vlan 4
Router(config-if)#
%LINEPROTO-5-UPDOWN: Line protocol on Interface Vlan4, changed state to down
Router(config-if)#ip address 172.20.52.97 255.255.255.224
Router(config-if)#no shutdown
Router(config-if)#
%LINEPROTO-5-UPDOWN: Line protocol on Interface Vlan4, changed state to up
Router(config-if)#
%LINK-3-UPDOWN: Interface Vlan4, changed state to up
Router(config-if)#exit
Router(config)#^Z
Router#
%SYS-5-CONFIG_I: Configured from console by vty0 (127.0.0.2)
Router#copy running-config startup-config
Building configuration...
[OK]
Router#
```

InterVLAN Routing with an External Cisco 7505 Router Example

Figure 39-4 shows the network configuration for this example. The switch has a 10/100-Mbps Fast Ethernet module in slot 2. Three hosts are connected to the switch, on ports 2/1, 2/2, and 2/3. The Cisco 7505 router has a Fast Ethernet interface processor in slot 2 and is connected to uplink port 1/1 on the switch supervisor engine.

Figure 39-4 InterVLAN Routing with External Cisco 7505 Example Configuration

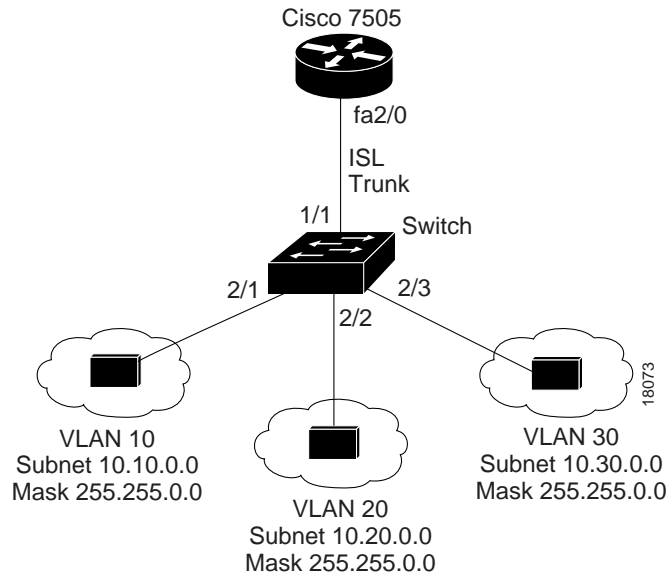

These configuration tasks must be performed to configure the network in this example:

- 1 Configure the switch as a VTP server and assign a VTP domain name.
- 2 Create the VLANs on the switch.
- 3 Assign each switch port to the appropriate VLAN.
- 4 Configure the uplink port as an ISL trunk.
- 5 On the router, create three subinterfaces, one for each VLAN configured on the switch.
- 6 Configure ISL encapsulation for each VLAN on the appropriate subinterface.
- 7 Assign IP addresses to the VLAN interfaces.

After you successfully configure the network, all end stations should be able to communicate with one another. Whenever a station in one VLAN transmits to a station in another VLAN, the traffic travels over the trunk link to the router. The router checks the routing table, determines the correct outgoing subinterface, and sends the traffic back over the trunk link to the switch. The switch forwards the traffic out the appropriate switch port.

Switch Configuration

This example shows how to configure the switch:

```
Switch> (enable) set vtp domain Corporate
VTP domain Corporate modified
Switch> (enable) set vtp mode server
VTP domain Corporate modified
Switch> (enable) set vlan 10
Vlan 10 configuration successful
Switch> (enable) set vlan 20
Vlan 20 configuration successful
Switch> (enable) set vlan 30
Vlan 30 configuration successful
Switch> (enable) set vlan 10 2/1
VLAN 10 modified.
VLAN 1 modified.
```

```

VLAN  Mod/Ports
-----
10    2/1

Switch> (enable) set vlan 20 2/2
VLAN 20 modified.
VLAN 1 modified.
VLAN  Mod/Ports
-----
20    2/2

Switch> (enable) set vlan 30 2/3
VLAN 30 modified.
VLAN 1 modified.
VLAN  Mod/Ports
-----
30    2/3

Switch> (enable) set trunk 1/1 on
Port(s) 1/1 trunk mode set to on.
Cat5000> (enable)

```

Cisco 7505 Configuration

This example shows how to configure the router:

```

Cisco7505#configure terminal
Enter configuration commands, one per line. End with CNTL/Z.
Cisco7505(config)#interface fastethernet2/0.10
Cisco7505(config-subif)#encapsulation isl 10
Cisco7505(config-subif)#ip address 10.10.1.1 255.255.0.0
Cisco7505(config-subif)#interface fastethernet2/0.20
Cisco7505(config-subif)#encapsulation isl 20
Cisco7505(config-subif)#ip address 10.20.1.1 255.255.0.0
Cisco7505(config-subif)#interface fastethernet2/0.30
Cisco7505(config-subif)#encapsulation isl 30
Cisco7505(config-subif)#ip address 10.30.1.1 255.255.0.0
Cisco7505(config-subif)#^Z
Cisco7505#%SYS-5-CONFIG_I: Configured from console by console

Cisco7505#copy running-config startup-config
Building configuration...
[OK]
Cisco7505#

```

InterVLAN Routing with an External Catalyst 8510 CSR Example

Figure 39-5 shows the network configuration for this example. Switch A is a Catalyst 5000 switch with a two-slot 48-port 10/100-Mbps Fast Ethernet module in slot 3. Four hosts are connected to the switch, on ports 3/1, 3/2, 3/25, and 3/26. Switch B is a Catalyst 2926 switch. Two hosts are connected to the switch, on ports 2/1 and 2/2.

The Catalyst 8510 CSR has a 100BaseTX Fast Ethernet module in slot 0. Interfaces fastethernet0/0/0 and 0/0/1 are connected to supervisor engine uplink ports 1/1 and 1/2 on Switch A through a channeled ISL trunk. Interface fastethernet0/0/2 is connected to supervisor engine uplink port 1/1 on Switch B through an ISL trunk.

Figure 39-5 InterVLAN Routing with External Catalyst 8510 CSR Example Configuration

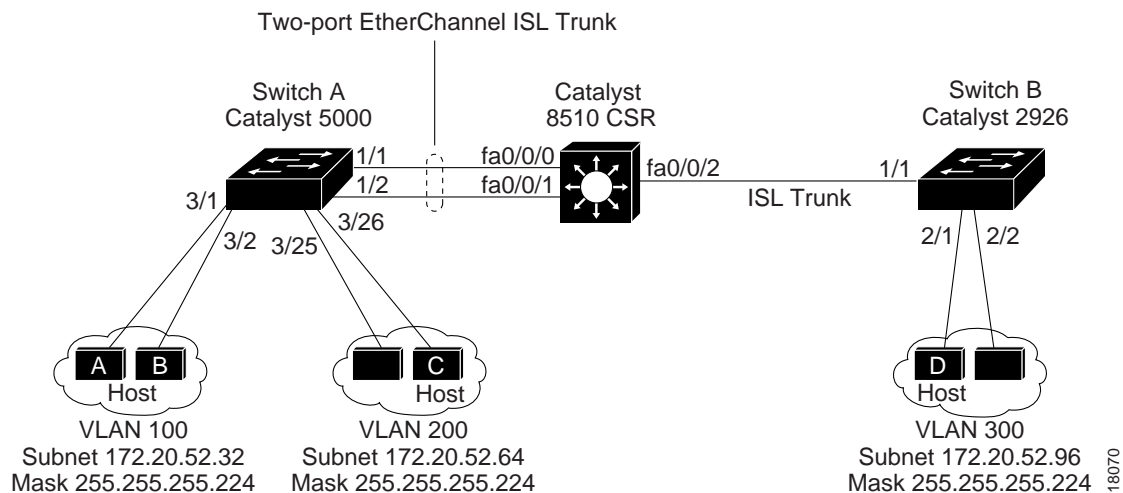

These configuration tasks must be performed to configure the network in this example:

- 1 Configure a port-channel interface on the Catalyst 8510 CSR to support the EtherChannel link to Switch A.
- 2 Assign the fastethernet0/0/0 and fastethernet0/0/1 interfaces to the port-channel interface.
- 3 Configure two subinterfaces on the port-channel interface, one for each VLAN configured on Switch A (VLANs 100 and 200).
- 4 Configure a subinterface on the fastethernet0/0/2 interface for the VLAN configured on Switch B (VLAN 300).
- 5 Configure ISL encapsulation on each subinterface.
- 6 Assign an IP address to each subinterface.
- 7 Configure Switch A as a VTP server and assign a VTP domain name.
- 8 Configure Switch B as a VTP server and assign it the same VTP domain name you configured on Switch A.
- 9 Create the VLANs (VLANs 100, 200, and 300) on both switches.
- 10 Assign the switch ports on each switch to the appropriate VLAN.
- 11 Configure a Fast EtherChannel bundle on the Switch A uplink ports.
- 12 Configure the EtherChannel as an ISL trunk.
- 13 Configure the Switch B uplink port as an ISL trunk.

After you successfully configure the network, all end stations should be able to communicate with one another. Whenever a station in one VLAN transmits to a station in another VLAN, the traffic travels over the trunk link to the router. The router checks the routing table, determines the correct outgoing subinterface, and sends the traffic out the appropriate subinterface. The switch forwards the traffic out the appropriate switch port.

Catalyst 8510 CSR Configuration

This example shows how to configure the Catalyst 8510 CSR:

```
8510CSR#configure terminal
8510CSR(config)#interface port-channel1
8510CSR(config-if)#interface fa0/0/0
8510CSR(config-if)#channel-group 1

FastEthernet0/0/0 added as member-1 to port-channel1
8510CSR(config-if)#
00:20:20: %LINK-3-UPDOWN: Interface Port-channel1, changed state to up
00:20:21: %LINEPROTO-5-UPDOWN: Line protocol on Interface Port-channel1, changed state
to up

8510CSR(config)#interface fa0/0/1
8510CSR(config-if)#channel-group 1

FastEthernet0/0/1 added as member-2 to port-channel1
8510CSR(config-if)#interface port-channel 1.100
8510CSR(config-subif)#encapsulation isl 100
8510CSR(config-subif)#ip address 172.20.52.33 255.255.255.224
8510CSR(config-subif)#interface port-channel 1.200
8510CSR(config-subif)#encapsulation isl 200
8510CSR(config-subif)#ip address 172.20.52.65 255.255.255.224
8510CSR(config-subif)#interface fa0/0/2
8510CSR(config-if)#interface fa0/0/2.300
8510CSR(config-subif)#encapsulation isl 300
8510CSR(config-subif)#ip address 172.20.52.97 255.255.255.224
8510CSR(config-subif)#^Z
8510CSR#
00:26:05: %SYS-5-CONFIG_I: Configured from console by console
8510CSR#
```

Switch A Configuration

This example shows how to configure Switch A:

```
SwitchA> (enable) set port channel 1/1-2 on
Port(s) 1/1-2 channel mode set to on.
SwitchA> (enable) %PAGP-5-PORTFROMSTP:Port 1/1 left bridge port 1/1
%PAGP-5-PORTFROMSTP:Port 1/2 left bridge port 1/2
%PAGP-5-PORTTOSTP:Port 1/1 joined bridge port 1/1-2
%PAGP-5-PORTTOSTP:Port 1/2 joined bridge port 1/1-2

SwitchA> (enable) show port channel
Port  Status      Channel  Channel  Neighbor  Neighbor
      mode        status   device
-----
1/1   connected    on       channel  cisco C8510 8510CSR  FastEther
1/2   connected    on       channel  cisco C8510 8510CSR  FastEther
-----

SwitchA> (enable) set trunk 1/1 on
Port(s) 1/1-2 trunk mode set to on.
SwitchA> (enable) %DTP-5-TRUNKPORTON:Port 1/1 has become isl trunk
%DTP-5-TRUNKPORTON:Port 1/2 has become isl trunk
%PAGP-5-PORTFROMSTP:Port 1/1 left bridge port 1/1-2
%PAGP-5-PORTFROMSTP:Port 1/2 left bridge port 1/1-2
%PAGP-5-PORTTOSTP:Port 1/1 joined bridge port 1/1-2
%PAGP-5-PORTTOSTP:Port 1/2 joined bridge port 1/1-2

SwitchA> (enable) show trunk 1/1
Port      Mode      Encapsulation  Status      Native vlan
-----
1/1      on        isl             trunking    1
```

InterVLAN Routing Configuration Examples

```
Port      Vlans allowed on trunk
-----
1/1      1-1005

Port      Vlans allowed and active in management domain
-----
1/1      1

Port      Vlans in spanning tree forwarding state and not pruned
-----
1/1
SwitchA> (enable) set vtp domain Corporate mode server
VTP domain Corporate modified
SwitchA> (enable) set vlan 100
Vlan 100 configuration successful
SwitchA> (enable) set vlan 200
Vlan 200 configuration successful
SwitchA> (enable) set vlan 300
Vlan 300 configuration successful
SwitchA> (enable) set vlan 100 3/1-2
VLAN 100 modified.
VLAN 1 modified.
VLAN  Mod/Ports
-----
%PAGP-5-PORTFROMSTP:Port 3/1 left bridge port 3/1
100  1/1-2
      3/1-2

SwitchA> (enable) %PAGP-5-PORTFROMSTP:Port 3/2 left bridge port 3/2

SwitchA> (enable) %PAGP-5-PORTTOSTP:Port 3/1 joined bridge port 3/1
%PAGP-5-PORTTOSTP:Port 3/2 joined bridge port 3/2

SwitchA> (enable) set vlan 200 3/25-26
VLAN 200 modified.
VLAN 1 modified.
VLAN  Mod/Ports
-----
200  1/1-2
      3/25-26

SwitchA> (enable) %PAGP-5-PORTFROMSTP:Port 3/25 left bridge port 3/25
%PAGP-5-PORTFROMSTP:Port 3/26 left bridge port 3/26
%PAGP-5-PORTTOSTP:Port 3/25 joined bridge port 3/25
%PAGP-5-PORTTOSTP:Port 3/26 joined bridge port 3/26

SwitchA> (enable)
```

Switch B Configuration

This example shows how to configure Switch B:

```
SwitchB> (enable) set vtp domain Corporate mode server
VTP domain Corporate modified
SwitchB> (enable) set vlan 100
Vlan 100 configuration successful
SwitchB> (enable) set vlan 200
Vlan 200 configuration successful
SwitchB> (enable) set vlan 300
Vlan 300 configuration successful
SwitchB> (enable) set trunk 1/1 on
Port(s) 1/1 trunk mode set to on.
SwitchB> (enable) 01/15/1999,09:59:26:DTP-5:Port 1/1 has become isl trunk
```

```
01/15/1999,09:59:26:PAGP-5:Port 1/1 left bridge port 1/1.

SwitchB> (enable)
SwitchB> (enable) 01/15/1999,09:59:37:PAGP-5:Port 1/1 joined bridge port 1/1.

SwitchB> (enable) set vlan 300 2/1-2
VLAN 300 modified.
VLAN 1 modified.
VLAN  Mod/Ports
---- -----
300   1/1
      2/1-2

SwitchB> (enable)
```