

Configuring ATM PVCs and PVCs with Traffic Shaping

This chapter describes how to configure permanent virtual connection (PVC)-supported virtual LANs (VLANs) and PVC-supported VLANs with traffic shaping for the Catalyst 5000 series ATM modules.

Note For complete information on installing Catalyst 5000 series ATM modules, refer to the *Catalyst 5000 Series Module Installation Guide*.

Note For complete syntax and usage information for the commands used in this chapter, refer to the *Command Reference* for your switch.

This chapter consists of these sections:

- Understanding How ATM PVC Traffic Shaping Works on page 36-1
- Default ATM PVC Traffic-Shaping Configuration on page 36-5
- Configuring PVC-Supported VLANs on page 36-5
- ATM PVC Traffic-Shaping Configuration Examples on page 36-7

Understanding How ATM PVC Traffic Shaping Works

PVC-based ATM links allow Catalyst 5000 series switches to connect to each other through ATM interfaces over PVCs. You can configure one or more PVCs for each VLAN on every Catalyst 5000 series ATM module. Connectivity can be back-to-back or through an ATM switch cloud, using RFC 1483-compliant, bridged Logical Link Control/Subnetwork Access Protocol (LLC/SNAP) packet encapsulation.

When you create a PVC, you create a virtual channel descriptor (VCD) and attach it to the virtual path identifier (VPI) and virtual channel identifier (VCI). A VCD identifies the VPI-VCI pair for a particular packet. The ATM module requires this feature to manage packet transmission. The number chosen for the VCD is independent of the VPI-VCI pair used.

To use PVCs, you must configure PVCs in both the Catalyst 5000 series ATM module and the ATM switch cloud. PVCs remain active until the circuit is removed from either configuration.

PVCs are compatible with switched virtual connection (SVC)-based LAN Emulation (LANE), with the following restrictions:

- You can configure a VLAN using either LANE or PVCs. You cannot configure the same VLAN to use both PVCs and LANE simultaneously.
- Only RFC-1483, bridged-Ethernet LLC/SNAP encapsulation is supported.
- If two PVCs are configured on the same VLAN and ATM module, packets received from one PVC are not forwarded to the other PVC.

You can configure PVCs with Catalyst 5000 series ATM software release 3.2 or with ATM PVC traffic-shaping software release 50.1 or 51.1. Software releases 50.1 and 51.1 allow you to configure a VLAN to run over PVCs so that you can specify a cell rate for traffic flow.

Note Software releases 50.1 and 51.1 are separate images from the Catalyst 5000 series LANE/MPOA software; software releases 50.1 and 51.1 do not support traffic shaping with LANE and support only RFC 1483-bridged Ethernet SNAP-encapsulated PVCs with peak cell-rate shaping.



Caution The ATM single PHY OC-3, dual PHY OC-3, and dual PHY DS3 modules require compatible releases of the Catalyst 5000 series supervisor engine and ATM PVC traffic-shaping software. See Table 36-1 for a list of ATM modules and compatible software releases.

Table 36-1 ATM Module Software Release Compatibility

Module	Product Number	Supervisor Engine Software Release	ATM PVC Software Release
ATM Single PHY OC-3	WS-X5153 WS-X5154 WS-X5155	1.6 or above	50.1(1) or above
ATM Dual PHY OC-3	WS-X5156 WS-X5157 WS-X5158	2.1(5) or above	50.1(1) or above
ATM Dual PHY DS3	WS-X5166	3.1 or above	51.1(2) or above

Note The ATM dual PHY OC-3 modules (WS-X5167 and WS-X5168) and the ATM dual PHY OC-12 modules (WS-X5161 and WS-X5162) do not support the ATM PVC traffic-shaping software.

Figure 36-1 shows two Catalyst 5000 series switches with ATM dual PHY DS3 modules in a redundant configuration running ATM PVC traffic-shaping software. The ATM dual PHY DS3 modules contain ten rate queues. Twenty-four PVCs are divided among the ten rate queues; each specifies a particular cell rate for the PVC set attached to it. In this example, PVC 1 through PVC 7 are in VLAN 1, PVC 8 through PVC 20 are in VLAN 2, and PVC 21 through PVC 24 are in VLAN 3.

To configure ATM PVC traffic shaping, you must assign a specified cell rate to a PVC. The software places the PVC to which the cell rate has been assigned in a dynamically created rate queue. The software creates rate queues, and you can assign each queue a unique cell-rate value.

Ten rate queues are available on any ATM module. However, the allowable peak cell rate (PCR) range varies depending on the software release and ATM module you are using, as follows:

- In software release 50.1 (which only supports OC-3 ATM modules), eight rate queues are available with a PCR range of 2081 to 155,000 kbps.
- In software release 51.1 with an OC-3 module, eight rate queues are available with a PCR range of 2081 to 155,000 kbps, and two rate queues are available with a PCR range of 1 to 2080 kbps.
- In software release 51.1 with a DS3 module, eight rate queues are available with a PCR range of 2081 to 45,000 kbps, and two rate queues are available with a PCR range of 1 to 2080 kbps.

You can configure up to 4096 PVCs on the ATM module. In addition, you can divide the PVCs attached to the rate queues among different VLANs. Traffic shaping supports only PCR.

If you enable VLAN Trunk Protocol (VTP) in the ATM module, the ATM module creates LAN Emulation Clients (LECs) for each VLAN configured on the supervisor engine module. The ATM module software also deletes a previously existing LEC for a particular VLAN when that LEC is configured to run over a PVC.

Figure 36-1 ATM PVC Traffic Shaping with the ATM Dual PHY DS3 Module

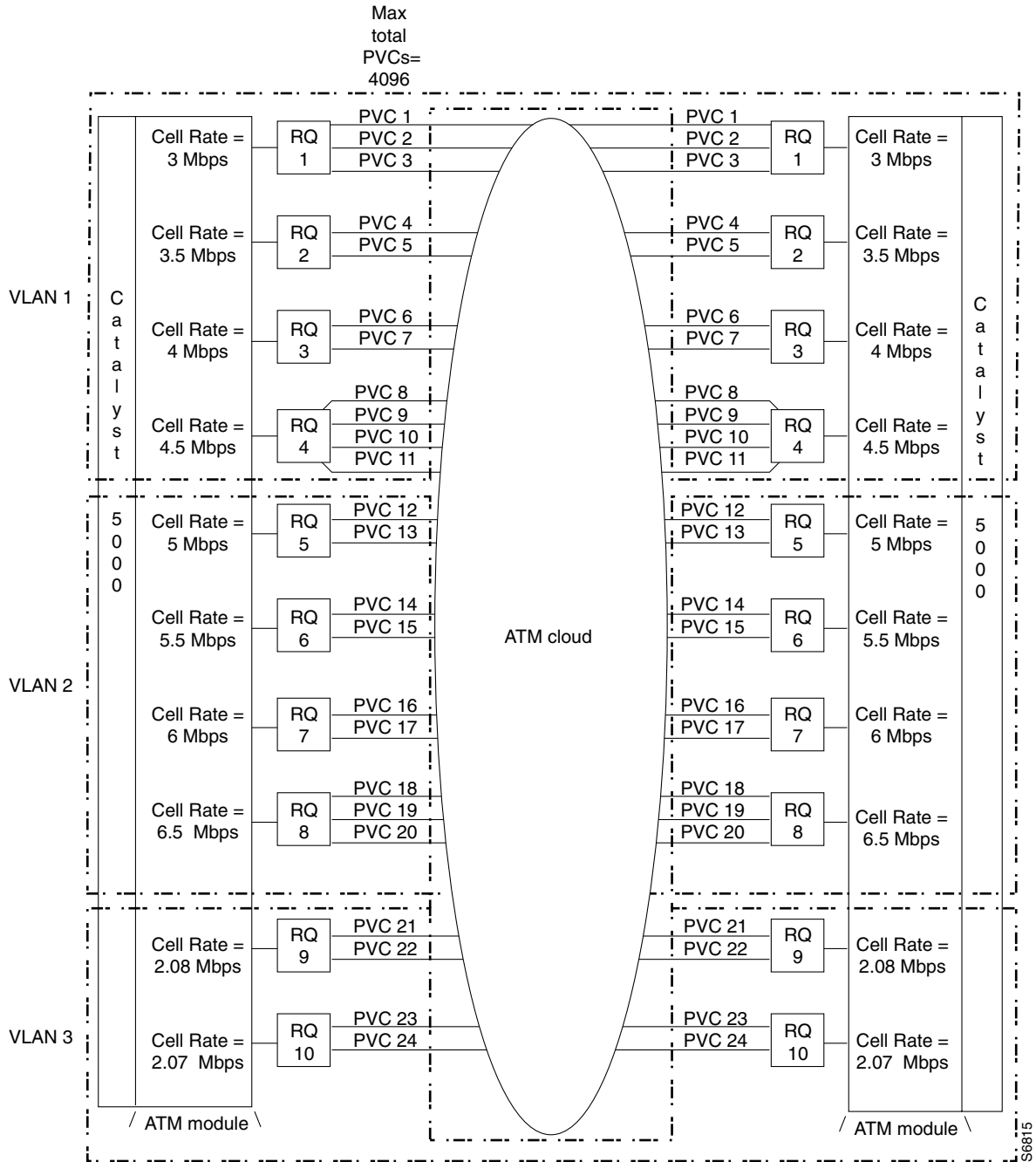

Default ATM PVC Traffic-Shaping Configuration

Table 36-2 shows the default ATM PVC traffic-shaping configuration.

Table 36-2 Default Fast Ethernet and Gigabit Ethernet Trunk Configuration

Feature	Default Configuration
Clock internal	Transmit clock is generated internally
ATM framing	C-Bit with ADM
Line buildout	Short
DS3-scramble	Disabled

Configuring PVC-Supported VLANs

These sections describe how to configure PVC-supported VLANs on the Catalyst 5000 series ATM modules:

- Setting Up PVCs in the ATM Cloud on page 36-5
- Configuring a PVC-Supported VLAN on page 36-5
- Configuring a PVC-Supported VLAN with Traffic-Shaping on page 36-6
- Unbinding or Removing PVCs from a VLAN on page 36-6

Setting Up PVCs in the ATM Cloud

To configure a PVC within the ATM cloud, refer to the documentation from your ATM switch vendor.

Configuring a PVC-Supported VLAN

To set up a PVC-supported VLAN on the ATM module, perform this task in privileged mode:

Task	Command
Step 1 On the Catalyst 5000 series switch, assign an Ethernet port to the desired VLAN.	set vlan <i>vlan_num mod_num/port_num</i>
Step 2 Establish a connection to the ATM module.	session <i>mod_num</i>
Step 3 Activate privileged mode on the ATM module.	enable
Step 4 Enter configuration mode.	configure terminal
Step 5 Select the ATM interface.	interface atm0
Step 6 Set up the PVCs.	atm pvc <i>vcd vpi vci aal5snap</i>
Step 7 Bind the PVCs to the VLAN.	atm bind pvc vlan <i>vcd vlan_num</i>
Step 8 (Optional) Set up other PVCs for the same VLAN if needed by repeating Steps 6 and 7.	
Step 9 Exit configuration mode.	Ctrl-Z
Step 10 Verify the PVC configuration.	show atm vlan show atm vc
Step 11 Save the configuration.	write memory

Configuring a PVC-Supported VLAN with Traffic-Shaping

Note Traffic shaping requires software release 50.1 or release 51.1.

To configure a PVC-supported VLAN with ATM PVC traffic-shaping, perform this task in privileged mode:

Task	Command
Step 1 Assign an Ethernet port to the desired VLAN.	set vlan <i>vlan_num mod_num/port_num</i>
Step 2 Establish a connection to the ATM module.	session <i>mod_num</i>
Step 3 Activate privileged mode on the ATM module.	enable
Step 4 Enter configuration mode.	configure terminal
Step 5 Select the ATM interface.	interface atm0
Step 6 (Optional) Customize the interface configuration if needed.	atm clock internal atm framing [m23adm cbitplcp m23plcp] atm lbo {short long} atm ds3-scrumble
Step 7 Set up the PVCs, indicating the desired peak cell rate.	atm pvc <i>vcd vpi vci</i> [aal-encap] aal5snap ¹ peak ² [oam seconds]
Step 8 Bind the PVCs to the VLAN.	atm bind pvc vlan <i>vcd vlan_num</i> ³
Step 9 Set up other PVCs for the same VLAN if needed by repeating Steps 6 through 8.	
Step 10 Exit configuration mode.	Ctrl-Z
Step 11 Verify the setup.	show atm vlan show atm vc
Step 12 Write the configuration to NVRAM.	write memory

- 1 To configure traffic shaping, you must use the **aal5snap** options.
- 2 The *peak* argument must not exceed 45000 for DS3 modules or 155000 for OC-3 modules.
- 3 The **atm bind pvc vlan vcd vlan_num** command is valid only for the current software release; this command may change in future releases.

Note The **atm bind pvc vlan vcd vlanid** command is valid only for the current software release. The **atm traffic-shape rate** command is not available in software releases 50.1 or 51.1.

Unbinding or Removing PVCs from a VLAN

You can unbind and remove a previously assigned PVC from a VLAN. You can also unbind a previously assigned PVC from a VLAN without removing the PVC itself. If you do not remove the PVC itself, you can bind the PVC to a different VLAN.

Note The procedures in this section apply to ATM software release 4.1 and ATM PVC traffic-shaping software release 50.1.

To remove a previously assigned PVC from a VLAN, perform this task in privileged mode:

Task	Command
Step 1 Enter privileged mode on the ATM module.	enable
Step 2 Enter configuration mode.	configure terminal
Step 3 Select the ATM interface.	interface atm0
Step 4 Remove the PVC from the VLAN.	no atm pvc vcd
Step 5 End the session.	Ctrl-Z

To unbind a previously assigned PVC from a VLAN without removing the PVC itself, perform this task in privileged mode:

Task	Command
Step 1 Activate privileged mode on the ATM module.	enable
Step 2 Enter configuration mode.	configure terminal
Step 3 Select the ATM interface.	interface atm0
Step 4 Unbind the PVC from the VLAN.	no atm bind pvc vlan vcd vlan_num
Step 5 End the session.	Ctrl-Z

ATM PVC Traffic-Shaping Configuration Examples

These sections show ATM PVC traffic-shaping configuration examples:

- Nonredundant Configuration Traffic-Shaping Example on page 36-7
- Redundant Configuration Traffic-Shaping Example on page 36-13

Nonredundant Configuration Traffic-Shaping Example

This example configuration describes how to configure a nonredundant PVC-supported VLAN configuration with traffic-shaping. Figure 36-2 shows the network used in this example. Assume that the ATM module in each Catalyst 5000 series switch is in slot 2. This example applies to both the single and dual PHY OC-3 ATM modules and the dual PHY DS3 ATM module.

Figure 36-2 Nonredundant Configuration Traffic-Shaping Example Network

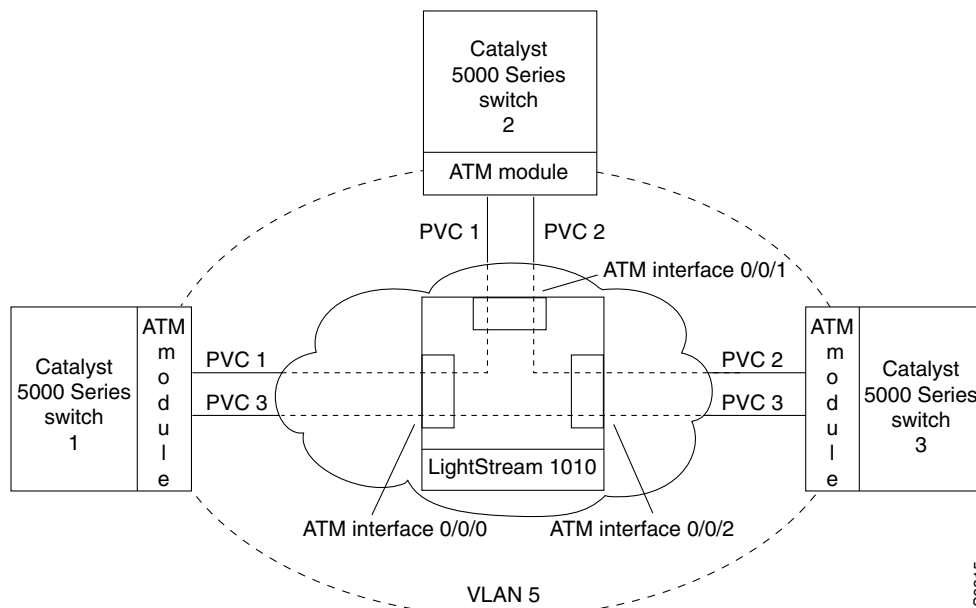

Table 36-3 shows the VLAN and switch connections, VPIs, VCIs, and traffic rates for the network shown in Figure 36-3.

Table 36-3 PVC Connections for Example Network

PVC	VLAN/Switch Connections	VPI	VCI	Rate in kbps
1	Connects Switch 1 to Switch 2 on VLAN 5	0	32	45000
2	Connects Switch 2 to Switch 3 on VLAN 5	0	33	2080
3	Connects Switch 1 to Switch 3 on VLAN 5	0	34	45000

These assumptions apply for this example:

- PVC 3 is required for Switch 1 to communicate with Switch 3, because the ATM module on Switch 2 does not forward packets received from Switch 1 on PVC 1 to Switch 3 on PVC 2.
- Any number of PVCs can be bound to the same VLAN. However, to prevent loops, each PVC must uniquely connect a VLAN group between two Catalyst 5000 series switches. You can also enable the Spanning-Tree Protocol to prevent loops.

Before configuring the VLAN over PVCs, you must perform these tasks:

- Verify that you have software release 50.1 or later.
- Obtain the VLAN number to be configured.
- Obtain the VPI and VCI for each PVC to be configured.
- Note the interface number on the LightStream 1010 ATM switch to which the ATM module is connected. You need this interface number to connect the PVCs across the ATM cloud on the LightStream 1010 switch.

Set up the PVCs within the ATM cloud.

Note These procedures apply only if your ATM switch is a Cisco LightStream 1010 ATM switch. If you have a different ATM switch, consult the documentation provided by the switch vendor.

Step 1 Create PVC 1 within the ATM cloud. Enter these commands on the LightStream 1010 ATM switch:

```
Switch> enable
Switch#
Switch# configure terminal
Enter configuration commands, one per line. End with CNTL/Z.
Switch(config)# interface atm0/0/0
Switch(config-if)# atm pvc 0 32 interface atm0/0/1 0 32
Switch(config-if)# end
Switch#
```

Step 2 Verify the setup of PVC 1. Enter this command on the LightStream 1010 ATM switch:

```
Switch# show atm vc interface atm0/0/0
```

Interface	VPI	VCI	Type	X-Interface	X-VPI	X-VCI	Status
ATM0/0/0	0	5	PVC	ATM2/0/0	0	32	UP
ATM0/0/0	0	16	PVC	ATM2/0/0	0	33	UP
ATM0/0/0	0	18	PVC	ATM2/0/0	0	34	UP
ATM0/0/0	0	32	PVC	ATM0/0/1	0	32	UP

```
Switch#
```

Step 3 Create PVC 2 within the ATM cloud. Enter these commands on the LightStream 1010 ATM switch:

```
Switch# configure terminal
Enter configuration commands, one per line. End with CNTL/Z.
Switch(config)#
Switch(config)# interface atm0/0/1
Switch(config-if)# atm pvc 0 33 interface atm0/0/2 0 33
Switch(config-if)# end
Switch#
```

Step 4 Verify the setup of PVC 2. Enter this command on the LightStream 1010 ATM switch:

```
Switch# show atm vc interface atm0/0/1
```

Interface	VPI	VCI	Type	X-Interface	X-VPI	X-VCI	Status
ATM0/0/1	0	5	PVC	ATM2/0/0	0	35	UP
ATM0/0/1	0	16	PVC	ATM2/0/0	0	36	UP
ATM0/0/1	0	18	PVC	ATM2/0/0	0	37	UP
ATM0/0/1	0	32	PVC	ATM0/0/0	0	32	UP
ATM0/0/1	0	33	PVC	ATM0/0/2	0	33	UP

```
Switch#
```

Step 5 Create PVC 3 within the ATM cloud. Enter these commands on the LightStream 1010 ATM switch:

```
Switch# configure terminal
Enter configuration commands, one per line. End with CNTL/Z.
Switch(config-if)# interface atm0/0/2
Switch(config-if)# atm pvc 0 34 interface atm0/0/0 0 34
Switch(config-if)# end
Switch#
```

Step 6 Verify the setup of PVC 3. Enter this command on the LightStream 1010 ATM switch:

```
Switch# show atm vc interface atm0/0/2
Interface      VPI      VCI      Type      X-Interface  X-VPI    X-VCI    Status
ATM0/0/2      0         5        PVC       ATM2/0/0     0        38       UP
ATM0/0/2      0         16       PVC       ATM2/0/0     0        39       UP
ATM0/0/2      0         18       PVC       ATM2/0/0     0        40       UP
ATM0/0/2      0         33       PVC       ATM0/0/1     0        33       UP
ATM0/0/2      0         34       PVC       ATM0/0/0     0        34       UP
Switch#
```

Set up PVC 1 and PVC 3 on the Catalyst 5000 series Switch 1.

Step 7 At the console of the Catalyst 5000 series Switch 1, establish a connection to the ATM module in slot 2 by entering these commands:

```
Console> enable
Enter password:
Console> (enable) set vlan 5
Console> (enable) session 2
Trying ATM-2...
Connected to ATM-2.
Escape character is '^]'.
ATM>
```

Step 8 Configure PVC 1 and PVC 3 on Switch 1 by entering these commands:

```
ATM> enable
ATM# configure terminal
Enter configuration commands, one per line. End with CNTL/Z.
ATM(config)# interface atm0
ATM(config-if)# atm pvc 10 0 32 aal5snap 45000
ATM(config-if)# atm ds3-scrumble
ATM(config-if)# atm lbo long
ATM(config-if)# atm framing m23adm
ATM(config-if)# atm clock internal
ATM(config-if)# atm pvc 11 0 34 aal5snap 45000
ATM(config-if)# end
ATM#
```

You can perform all PVC-related configurations for all VLANs on atm0, the major interface, because the subinterface number has no significance for PVC-supported VLANs. VCDs 10 and 11 (used above) can be any unused VCDs. Enter the **show atm vc** command to find unused VCDs.

Step 9 Bind PVC 1 and PVC 3 to VLAN 5 on Switch 1 by entering these commands:

```
ATM# configure terminal
Enter configuration commands, one per line. End with CNTL/Z.
ATM(config)# interface atm0
ATM(config-if)# atm bind pvc vlan 10 5
ATM(config-if)# atm bind pvc vlan 11 5
ATM(config-if)# end
ATM#
```

Enter the VCD numbers used in Step 8. The last option in the **atm bind pvc** command specifies VLAN 5.

Step 10 Verify the setup on Switch 1 by entering these commands:

```
ATM# show atm vlan
VCD      VLAN-ID
10       5
11       5
ATM#
ATM# show atm vc
```

Interface	VCD	VPI	VCI	Type	AAL/ Encapsulation	Peak Kbps	Avg. Kbps	Burst Cells	Status
ATM0	10	0	32	PVC	AAL5-SNAP	45000	0	0	ACTIVE
ATM0	11	0	34	PVC	AAL5-SNAP	45000	0	0	ACTIVE

```
ATM#
```

Step 11 Save the configuration as follows:

```
ATM# write memory
Building configuration...
[OK]
ATM#
```

Set up PVC 1 and PVC 2 on the Catalyst 5000 series Switch 2.

Step 12 At the console of the Catalyst 5000 series Switch 2, establish a connection to the ATM module in slot 2 by entering these commands:

```
Console> enable
Enter password:
Console> (enable) set vlan 5
Console> (enable) session 2
Trying ATM-2...
Connected to ATM-2.
Escape character is '^'.
ATM#
```

Step 13 Configure PVC 1 and PVC 2 on Switch 2 by entering these commands:

```
ATM> enable
ATM# configure terminal
Enter configuration commands, one per line. End with CNTL/Z.
ATM(config)# interface atm0
ATM(config-if)# atm pvc 10 0 32 aal5snap 45000
ATM(config-if)# atm ds3-scrumble
ATM(config-if)# atm lbo long
ATM(config-if)# atm framing m23adm
ATM(config-if)# atm clock internal
ATM(config-if)# atm pvc 11 0 33 aal5snap 2080
ATM(config-if)# end
ATM#
```

You can perform all PVC-related configurations for all VLANs on atm0, the major interface, because the subinterface number has no significance for PVC-supported VLANs. VCDs 10 and 11 (used above) can be any unused VCDs. Enter the **show atm vc** command to find unused VCDs.

Step 14 Bind PVC 1 and PVC 2 to VLAN 5 on Switch 2 by entering these commands:

```
ATM# configure terminal
Enter configuration commands, one per line. End with CNTL/Z.
ATM(config)# interface atm0
ATM(config-if)# atm bind pvc vlan 10 5
ATM(config-if)# atm bind pvc vlan 11 5
ATM(config-if)# end
ATM#
```

Enter the VCDs used in Step 13. The last option in the **atm bind pvc** command specifies VLAN 5.

Step 15 Verify the setup on Switch 2 by entering these commands:

```
ATM# show atm vlan
VCD      VLAN-ID
  10      5
  11      5
ATM#
ATM# show atm vc
```

Interface	VCD	VPI	VCI	Type	AAL / Encapsulation	Peak Kbps	Avg. Kbps	Burst Cells	Status
ATM0	10	0	32	PVC	AAL5-SNAP	45000	0	0	ACTIVE
ATM0	11	0	33	PVC	AAL5-SNAP	2080	0	0	ACTIVE

```
ATM#
```

Step 16 Save the configuration as follows:

```
ATM# write memory
Building configuration...
[OK]
ATM#
```

Set up PVC 2 and PVC 3 on the Catalyst 5000 series Switch 3.

Step 17 At the console of the Catalyst 5000 series Switch 3, establish a connection to the ATM module in slot 2 by entering these commands:

```
Console> enable
Enter password:
Console> (enable) set vlan 5
Console> (enable) session 2
Trying ATM-2...
Connected to ATM-2.
Escape character is '^]'.
ATM>
```

Step 18 Configure PVC 2 and PVC 3 on Switch 3 by entering these commands:

```
ATM> enable
ATM# configure terminal
Enter configuration commands, one per line. End with CNTL/Z.
ATM(config)# interface atm0
ATM(config-if)# atm pvc 10 0 33 aal5snap 2080
ATM(config-if)# atm pvc 11 0 34 aal5snap 45000
ATM(config-if)# end
ATM#
```

You can perform all PVC-related configurations for all VLANs on atm0, the major interface, because the subinterface number has no significance for PVC-supported VLANs. VCDs 10 and 11 (used above) can be any unused VCDs. Enter the **show atm vc** command to find unused VCDs.

Step 19 Bind PVC 2 and PVC 3 to VLAN 5 on Switch 3 by entering these commands:

```
ATM# configure terminal
Enter configuration commands, one per line. End with CNTL/Z.
ATM(config)# interface atm0
ATM(config-if)# atm bind pvc vlan 10 5
ATM(config-if)# atm bind pvc vlan 11 5
ATM(config-if)# end
ATM#
```

Enter the VCDs used in Step 18. The last option in the **atm bind pvc** command specifies VLAN 5.

Step 20 Verify the setup on Switch 3 by entering these commands:

```
ATM# show atm vlan
VCD      VLAN-ID
  10      5
  11      5
ATM#
ATM# show atm vc
```

Interface	VCD	VPI	VCI	Type	AAL / Encapsulation	Peak Kbps	Avg. Kbps	Burst Cells	Status
ATM0	10	0	33	PVC	AAL5-SNAP	2080	0	0	ACTIVE
ATM0	11	0	34	PVC	AAL5-SNAP	45000	0	0	ACTIVE

ATM#

Step 21 Save the configuration as follows:

```
ATM# write memory
Building configuration...
[OK]
ATM#
```

Redundant Configuration Traffic-Shaping Example

Figure 36-3 shows the PVCs needed for complete redundancy if PHY A or PHY B on either Switch 1 or Switch 2 fails. This example (referred to as example 2) applies to the dual PHY DS3 module, but you can use the same configuration for dual PHY OC-3 modules (with appropriate PCRs).

Figure 36-3 Redundant PVC Traffic-Shaping

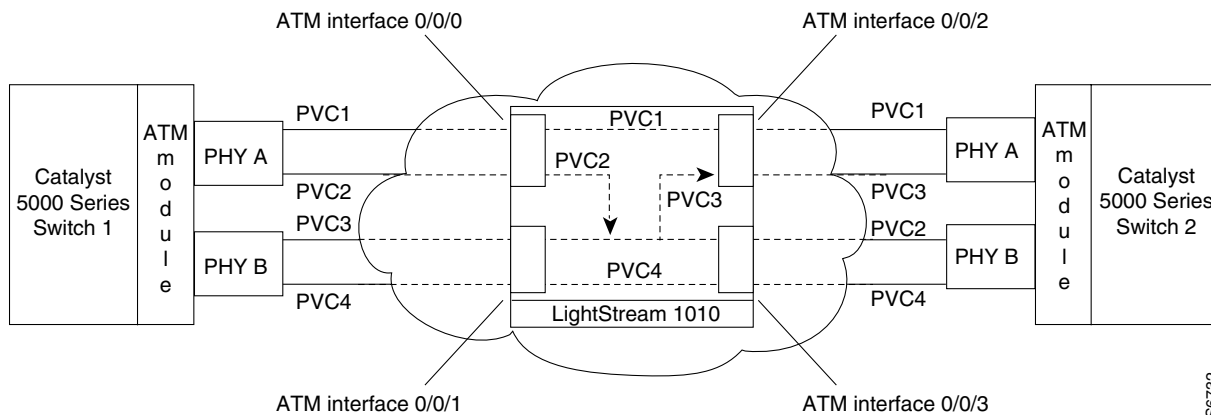

In Figure 36-3, you see Catalyst 5000 series Switch 1 and Catalyst 5000 series Switch 2, each with an ATM dual PHY DS3 module, connected to a LightStream 1010 ATM switch in the ATM cloud.

Assume PHY A on Switch 1 goes down and transmits no data to PHY A on Switch 2 over PVC 1, even though PHY A on Switch 2 remains active. When PHY A on Switch 1 goes down, PHY B on Switch 1 becomes active and transmits data to PHY B on Switch 2 over PVC 2.

Similarly, if PHY A on Switch 2 goes down and transmits no data to Switch 1 over PVC 1, PHY B on Switch 2 becomes active and transmits data to PHY B on Switch 1 over PVC 3.

Table 36-4 shows the PVCs used to transmit data when the specified PHYs for the Catalyst 5000 series switches in Figure 36-3 are active. For example, if PHY A on Switch 1 and PHY A on Switch 2 are both active, data is transmitted on PVC 1.

Table 36-4 Redundancy Coverage for Figure 36-3

Switch 1	Switch 2	PVC Used
PHY A— active	PHY A— active	1
PHY A— active	PHY B— active	2
PHY B— active	PHY A— active	3
PHY B— active	PHY B— active	4

Note To ensure redundancy for data transmission using dual PHYs, you must set up PVCs 1, 2, 3, and 4 on the same VLAN and configure the same data rate for each PVC.

The following assumptions apply for this example configuration:

- Table 36-5 lists the PVC and switch connections, VPI, VCI, and traffic rates shown in Figure 36-3.

Table 36-5 PVC Connections in Figure 36-2

PVC	Switch Connections	VPI	VCI	kbps Rate
1	Connects PHY A on Switch 1 to PHY A on Switch 2	0	32	45000
2	Connects PHY A on Switch 1 to PHY B on Switch 2	0	33	45000
3	Connects PHY B on Switch 1 to PHY A on Switch 2	0	34	45000
4	Connects PHY B on Switch 1 to PHY B on Switch 2	0	35	45000

- The ATM module is installed in slot 2 of the Catalyst 5000 series switches.
- Any number of PVCs can be bound to the same VLAN. However, to prevent loops, each PVC must uniquely connect a VLAN group between two Catalyst 5000 series switches. You can also enable Spanning-Tree Protocol to prevent loops.

Before configuring the VLAN over PVCs, you must perform these tasks:

- Verify that you have ATM module software release 51.1(2) or above.
- Obtain the VLAN number to be configured.
- Obtain the VPI and VCI for each PVC to be configured.
- Note the interface number of the LightStream 1010 ATM switch to which the Catalyst 5000 series ATM module is connected. You need this interface number to connect the PVCs across the ATM cloud on the LightStream 1010 ATM switch.

To configure the devices in this example, follow these steps:

Note These procedures apply only if your ATM switch is a Cisco LightStream 1010 ATM switch. If you have a different ATM switch, consult the publication that accompanied the switch.

Set up the PVCs within the ATM cloud.

Step 1 Create PVC 1 within the ATM cloud. Enter these commands on the LightStream 1010 ATM switch:

```
Switch> enable
Switch# configure terminal
Enter configuration commands, one per line. End with CNTL/Z.
Switch(config)# interface atm0/0/0
Switch(config-if)# atm pvc 0 32 int atm0/0/2 0 32
Switch(config-if)# end
Switch#
```

Step 2 Verify the setup of PVC 1. Enter this command on the LightStream 1010 ATM switch:

```
Switch# show atm vc interface atm0/0/0
```

Interface	VPI	VCI	Type	X-Interface	X-VPI	X-VCI	Status
ATM0/0/0	0	5	PVC	ATM2/0/0	0	32	UP
ATM0/0/0	0	16	PVC	ATM2/0/0	0	33	UP
ATM0/0/0	0	18	PVC	ATM2/0/0	0	34	UP
ATM0/0/0	0	32	PVC	ATM0/0/2	0	32	UP

```
Switch#
```

Step 3 Create PVC 2 within the ATM cloud. Enter these commands on the LightStream 1010 ATM switch:

```
Switch# configure terminal
Enter configuration commands, one per line. End with CNTL/Z.
Switch(config)# interface atm0/0/2
Switch(config-if)# atm pvc 0 33 int atm0/0/1 0 33
Switch(config-if)# end
Switch#
```

Step 4 Verify the setup of PVC 2. Enter this command on the LightStream 1010 ATM switch:

```
Switch# show atm vc interface atm0/0/2
```

Interface	VPI	VCI	Type	X-Interface	X-VPI	X-VCI	Status
ATM0/0/2	0	5	PVC	ATM2/0/0	0	38	UP
ATM0/0/2	0	16	PVC	ATM2/0/0	0	39	UP
ATM0/0/2	0	18	PVC	ATM2/0/0	0	40	UP
ATM0/0/2	0	32	PVC	ATM0/0/0	0	32	UP
ATM0/0/2	0	33	PVC	ATM0/0/1	0	33	UP

```
Switch#
```

Step 5 Create PVC 3 within the ATM cloud. Enter these commands on the LightStream 1010 ATM switch:

```
Switch# configure terminal
Enter configuration commands, one per line. End with CNTL/Z.
Switch(config)# interface atm0/0/3
Switch(config-if)# atm pvc 0 34 int atm0/0/0 0 34
Switch(config-if)# end
Switch#
```

Step 6 Verify the setup of PVC 3. Enter this command on the LightStream 1010 ATM switch:

```
Switch# show atm vc interface atm0/0/3
```

Interface	VPI	VCI	Type	X-Interface	X-VPI	X-VCI	Status
ATM0/0/3	0	5	PVC	ATM2/0/0	0	41	UP
ATM0/0/3	0	16	PVC	ATM2/0/0	0	42	UP
ATM0/0/3	0	18	PVC	ATM2/0/0	0	43	UP
ATM0/0/3	0	34	PVC	ATM0/0/0	0	34	UP

```
Switch#
```

Step 7 Create PVC 4 within the ATM cloud. Enter these commands on the LightStream 1010 ATM switch:

```
Switch# configure terminal
Enter configuration commands, one per line. End with CNTL/Z.
Switch(config)# interface atm0/0/1
Switch(config-if)# atm pvc 0 35 interface atm0/0/3 0 35
Switch(config-if)# end
Switch#
```

Step 8 Verify the setup of PVC 4. Enter this command on the LightStream 1010 ATM switch:

```
Switch# show atm vc interface atm0/0/1
```

Interface	VPI	VCI	Type	X-Interface	X-VPI	X-VCI	Status
ATM0/0/1	0	5	PVC	ATM2/0/0	0	35	UP
ATM0/0/1	0	16	PVC	ATM2/0/0	0	36	UP
ATM0/0/1	0	18	PVC	ATM2/0/0	0	37	UP
ATM0/0/1	0	33	PVC	ATM0/0/2	0	33	UP
ATM0/0/1	0	35	PVC	ATM0/0/3	0	35	UP

```
Switch#
```

Set up the PVCs on the Catalyst 5000 series Switch 1.

- Step 9** At the console of the Catalyst 5000 series Switch 1, session to the ATM module in slot 2 by entering these commands:

```
Console> enable
Enter password:
Console> (enable) session 2
Trying ATM-2...
Connected to ATM-2.
Escape character is '^]'.
ATM>
```

- Step 10** Configure PVCs 1, 2, 3, and 4 on Switch 1 by entering these commands:

```
ATM> enable
ATM# configure terminal
Enter configuration commands, one per line. End with CNTL/Z.
ATM(config)# interface atm0
ATM(config-if)# atm pvc 1 0 32 aal5snap 45000
ATM(config-if)# atm ds3-scrumble
ATM(config-if)# atm lbo long
ATM(config-if)# atm framing m23adm
ATM(config-if)# atm clock internal
ATM(config-if)# atm pvc 2 0 33 aal5snap 45000
ATM(config-if)# atm pvc 3 0 34 aal5snap 45000
ATM(config-if)# atm pvc 4 0 35 aal5snap 45000
ATM(config-if)# end
ATM#
```

You can perform all PVC-related configurations for all VLANs on atm0, the major interface, because the subinterface number has no significance for PVC-supported VLANs. VCDs 10 and 11 (used above) can be any unused VCDs. Enter the **show atm vc** command to find unused VCDs.

- Step 11** Bind the PVCs to VLAN 5 on the Switch 1 by entering these commands:

```
ATM# configure terminal
Enter configuration commands, one per line. End with CNTL/Z.
ATM(config)# interface atm0
ATM(config-if)# atm bind pvc vlan 1 5
ATM(config-if)# atm bind pvc vlan 2 5
ATM(config-if)# atm bind pvc vlan 3 5
ATM(config-if)# atm bind pvc vlan 4 5
ATM(config-if)# end
ATM#
```

Enter the VCD numbers used in Step 8. The last option in the **atm bind pvc** command specifies VLAN 5.

Step 12 Verify the setup on the Switch 1 by entering these commands:

```
ATM# show atm vlan
VCD    VLAN-ID
  1     5
  2     5
  3     5
  4     5
ATM#
ATM# show atm vc

```

Interface	VCD	VPI	VCI	Type	AAL / Encapsulation	Peak Kbps	Avg. Kbps	Burst Cells	Status
ATM0	1	0	32	PVC	AAL5-SNAP	45000	0	0	ACTIVE
ATM0	2	0	33	PVC	AAL5-SNAP	45000	0	0	ACTIVE
ATM0	3	0	34	PVC	AAL5-SNAP	45000	0	0	ACTIVE
ATM0	4	0	35	PVC	AAL5-SNAP	45000	0	0	ACTIVE

```
ATM#
```

Step 13 Save the configuration as follows:

```
ATM# write memory
Building configuration...
[OK]
ATM#
```

Set up the PVCs on the Catalyst 5000 series Switch 2.

Step 14 At the console of the Catalyst 5000 series Switch 2, session to the ATM module in slot 2 by entering these commands:

```
Console> enable
Enter password:
Console> (enable) set vlan 5
Console> (enable) session 2
Trying ATM-2...
Connected to ATM-2.
Escape character is '^]'.
ATM>
```

Step 15 Configure PVCs 1, 2, 3, and 4 on Switch 2 by entering these commands:

```
ATM> enable
ATM# configure terminal
Enter configuration commands, one per line. End with CNTL/Z.
ATM(config)# interface atm0
ATM(config-if)# atm pvc 1 0 32 aal5snap 45000
ATM(config-if)# atm ds3-scramble
ATM(config-if)# atm lbo long
ATM(config-if)# atm framing m23adm
ATM(config-if)# atm clock internal
ATM(config-if)# atm pvc 2 0 33 aal5snap 45000
ATM(config-if)# atm pvc 3 0 34 aal5snap 45000
ATM(config-if)# atm pvc 4 0 35 aal5snap 45000
ATM(config-if)# end
ATM#
```

You can perform all PVC-related configurations for all VLANs on atm0, the major interface, because the subinterface number has no significance for PVC-supported VLANs. VCDs 10 and 11 (used above) can be any unused VCDs. Enter the **show atm vc** command to find unused VCDs.

Step 16 Bind the PVCs to VLAN 5 on the Catalyst 5000 series Switch 2 by entering these commands:

```
ATM# configure terminal
Enter configuration commands, one per line. End with CNTL/Z.
ATM(config)# interface atm0
ATM(config-if)# atm bind pvc vlan 1 5
ATM(config-if)# atm bind pvc vlan 2 5
ATM(config-if)# atm bind pvc vlan 3 5
ATM(config-if)# atm bind pvc vlan 4 5
ATM(config-if)# end
ATM#
```

Step 17 Verify the setup on the Catalyst 5000 series Switch 2 by entering these commands:

```
ATM# show atm vlan
VCD      VLAN-ID
  1       5
  2       5
  3       5
  4       5
ATM#
ATM# show atm vc
```

Interface	VCD	VPI	VCI	Type	AAL / Encapsulation	Peak Kbps	Avg. Kbps	Burst Cells	Status
ATM0	1	0	32	PVC	AAL5-SNAP	45000	0	0	ACTIVE
ATM0	2	0	33	PVC	AAL5-SNAP	45000	0	0	ACTIVE
ATM0	3	0	34	PVC	AAL5-SNAP	45000	0	0	ACTIVE
ATM0	4	0	35	PVC	AAL5-SNAP	45000	0	0	ACTIVE

```
ATM#
```

Step 18 Save the configuration as follows:

```
ATM# write memory
Building configuration...
[OK]
ATM#
```

