

Configuring ATM LAN Emulation

This chapter describes how to configure the ATM LAN Emulation (LANE) on the Catalyst 5000 series ATM modules.

Note For complete information on installing Catalyst 5000 series ATM modules, refer to the *Catalyst 5000 Series Module Installation Guide*.

Note For complete syntax and usage information for the commands used in this chapter, refer to the *Command Reference* for your switch.

This chapter consists of these sections:

- Understanding How ATM LANE Works on page 35-1
- Default ATM LANE Configuration on page 35-8
- ATM LANE Configuration Guidelines on page 35-9
- Configuring ATM LANE on page 35-10
- Creating LECs Automatically Using VTP on page 35-24
- Configuring General ATM Parameters on page 35-26
- ATM LANE Configuration Examples on page 35-30

Understanding How ATM LANE Works

These sections describe how ATM LANE works on the Catalyst 5000 series switches:

- ATM LANE Overview on page 35-2
- ATM LANE Components on page 35-3
- LANE Operation and Communication on page 35-3
- Comparing VLANs and ELANs on page 35-4
- Joining a LEC to an ELAN on page 35-4
- ELAN Address Resolution on page 35-5
- Sending Multicast Traffic on page 35-6
- LANE ATM Addressing Structure on page 35-6

- Assigning ATM Addresses Automatically on page 35-7
- Registering ILMI Addresses on page 35-7
- Using VTP to Create LECs Automatically on page 35-7
- Drafting an ATM LANE Implementation Plan on page 35-8

ATM LANE Overview

ATM LANE permits an ATM network to be used as a high-speed backbone for hubs, bridges, and switches. In addition, LANE allows end stations to communicate with an ATM-attached device, such as a file server, through a LAN-to-ATM switch without requiring the traffic to pass through a router. LANE requires an ATM switch that supports User-Network Interface (UNI) 3.0 or 3.1 and point-to-multipoint signaling (for example, the Cisco LightStream 1010 ATM switch).

Note Cisco supports only Ethernet emulated LANs (ELANs).

LANE provides the following:

- Connectivity between ATM-attached stations and LAN-attached stations
- Connectivity between LAN-attached stations across an ATM network

Because LANE connectivity is defined at the Media Access Control (MAC) layer, upper-layer protocol functions of LAN applications can operate unchanged when the devices join ELANs. This feature protects corporate investments in legacy LAN applications.

An ATM network can support multiple independent ELANs. End-system membership in any of the ELANs is independent of the physical location of the end system, simplifying hardware adds, moves, and changes. In addition, the end systems can move easily from one ELAN to another, whether or not the hardware moves. Figure 35-1 shows a typical ATM LANE configuration. End stations in switched LANs are interconnected through an ATM network with ELANs configured.

Figure 35-1 Extending VLANs Using ATM LANE

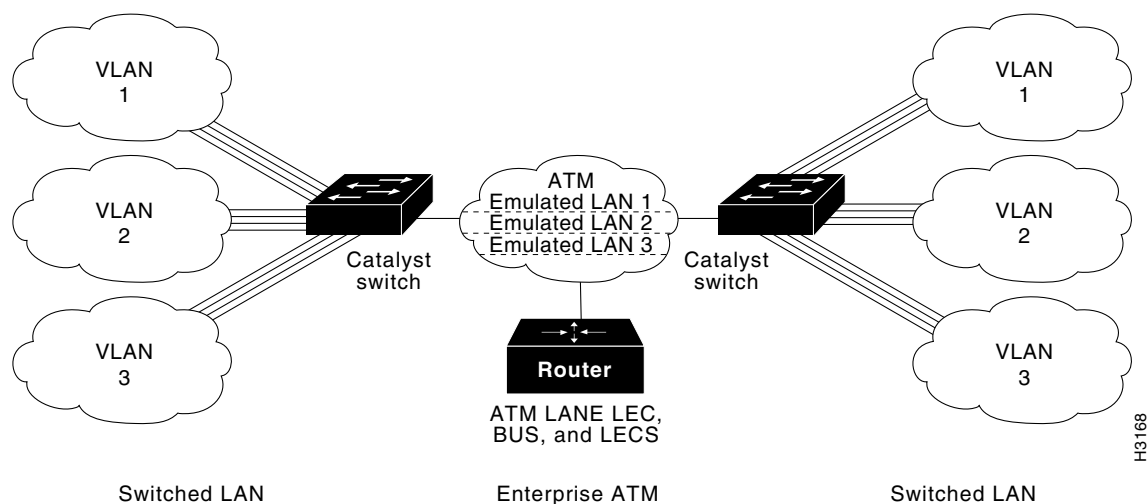

ATM LANE Components

You can set up an unlimited number of ELANs in an ATM cloud. A Catalyst 5000 series switch ATM module can participate in multiple ELANs.

LANE is defined on a client-server LAN model and consists of these components:

- LANE client (LEC)—A LEC emulates a LAN interface to higher-layer protocols and applications; it forwards data to other LANE components and performs LANE address-resolution functions. Each LEC is a member of only one ELAN. However, a router or a Catalyst 5000 series switch ATM module can include LECs for multiple ELANs—one LEC for *each* member of the ELAN. If a router has LECs for multiple ELANs, the router can route traffic between the ELANs.
- LANE server (LES)—The LES for an ELAN is the control center. It provides joining, address resolution, and address registration services to the LECs in that ELAN. LECs can register destination unicast and multicast MAC addresses with the LES. In addition, the LES handles LANE Address Resolution Protocol (LE ARP) requests and responses.
- LANE broadcast-and-unknown server (BUS)—The LANE BUS sequences and distributes multicast and broadcast packets and handles unicast flooding. At least one combined LES and BUS is required per ELAN.
- LANE configuration server (LECS)—The LECS contains the database that determines the ELAN to which a device belongs. Each configuration LES can have a differently named database. Each LEC consults the LECS only once—when it first joins an ELAN—to determine which ELAN it should join. The LECS returns the ATM address of the LES for that ELAN.

At least one LECS is required per ATM LANE switch cloud.

The LECS database can have the following four types of entries:

- ELAN_name, ATM_address_of_LES pairs
- LEC_MAC_address, ELAN_name pairs
- LEC_ATM_template, ELAN_name pairs
- Default_ELAN_name

ELAN names must be unique on an interface. If two interfaces participate in LANE, the second interface might be in a different switch cloud.

Note Multiple LESs, BUSs, and LECSs can exist for the same ELAN, providing redundancy.

LANE Operation and Communication

Typically, communication among LANE components is handled by several types of switched virtual channel connections (VCCs). Some VCCs are unidirectional; others are bidirectional. Some are point-to-point, and others are point-to-multipoint. Figure 35-2 illustrates the various types of VCCs.

Figure 35-2 LANE Virtual Channel Circuit Types

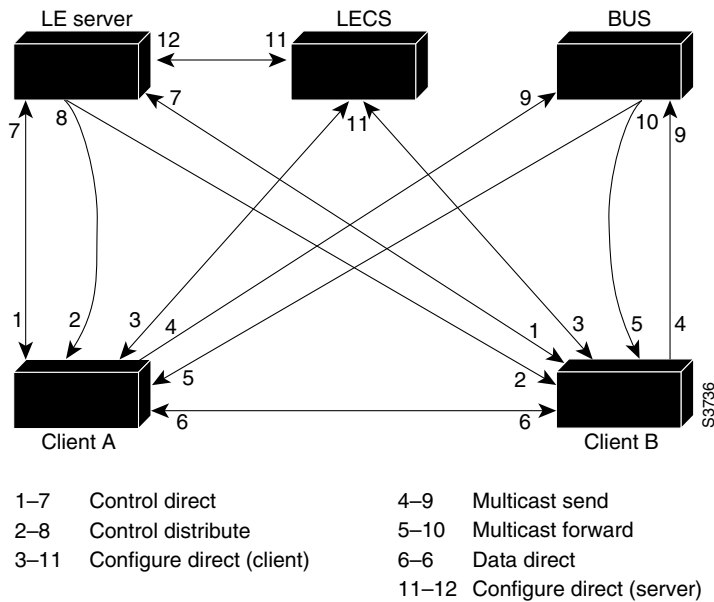

Comparing VLANs and ELANs

The Catalyst 5000 series switches support port-based virtual LAN (VLAN) configuration. An end station connected to a port belongs to the VLAN assigned to that port. The VLAN number identifies the VLAN.

On an ATM network, ELANs are designated by a name. You can configure some ELANs from a router and some from a Catalyst 5000 series switch. You can configure some ELANs with unrestricted membership and some with restricted membership. You can also configure a default ELAN, which must have unrestricted membership.

To create a VLAN that spans multiple Catalyst 5000 series switches across an ATM network, you must map a given ATM ELAN to the same VLAN configured on each Catalyst 5000 series switch. For example, if you have VLAN 10 configured on two different switches, you must map VLAN 10 to the same ATM ELAN. To communicate between two or more ELANs, you must use a router, whether the ELANs are on the same or different Catalyst 5000 series switches.

Joining a LEC to an ELAN

The following process (illustrated in Figure 35-2) occurs after you enable a LEC on the ATM module in a Catalyst 5000 series switch:

- 1 The LEC requests to join an ELAN.

The LEC sets up a connection to the LECS (bidirectional, point-to-point Configure Direct VCC, link 3-11 in Figure 35-2) to find the ATM address of the LES for its ELAN.

The LECs find the LECS by using the following interface and addresses in the listed order:

- (a) Locally configured ATM address
- (b) Integrated Local Management Interface (ILMI)
- (c) Fixed address defined by the ATM Forum

- 2 The LECS identifies the LES to the LEC.
Using the same VCC, the LECS returns the ATM address and the name of the LES for the LEC ELAN.
- 3 The LEC tears down Configure Direct VCC.
- 4 The LEC contacts the LES for its ELAN.
The LEC sets up a connection to the LES for its ELAN (bidirectional, point-to-point Control Direct VCC, link 1–7 in Figure 35-2) to exchange control traffic.
When a Control Direct VCC is established between a LEC and a LES, it remains established.
- 5 The LES verifies that the LEC is allowed to join the ELAN.
The LES for the ELAN sets up a connection to the LECS to verify that the LEC is allowed to join the ELAN (bidirectional, point-to-point Server Configure VCC, link 11–12 in Figure 35-2). The LES configuration request contains the LEC MAC address, its ATM address, and the name of the ELAN. The LECS checks its database to determine whether the LEC can join that ELAN and uses the same VCC to inform the LES whether or not the LEC is allowed to join.
- 6 The LES allows or does not allow the LEC to join the ELAN.
- 7 If allowed, the LES adds the LEC to the unidirectional, point-to-multipoint Control Distribute VCC (link 2–8 in Figure 35-2) and confirms the join over the bidirectional, point-to-point Control Direct VCC (link 1–7 in Figure 35-2). If not allowed, the LES rejects the join over the bidirectional, point-to-point Control Direct VCC (link 1–7 in Figure 35-2).
- 8 The LEC sends LE ARP packets for the broadcast address (all ones).
Sending LE ARP packets for the broadcast address returns the ATM address of the BUS. The LEC sets up the Multicast Send VCC (link 4–9 in Figure 35-2), and the BUS adds the LEC to the Multicast Forward VCC (link 5–10 in Figure 35-2) to and from the BUS.

ELAN Address Resolution

As communication occurs on the ELAN, each LEC dynamically builds a local LE ARP table. A LEC LE ARP table can also have static, preconfigured entries. The LE ARP table maps MAC addresses to ATM addresses.

Note LE ARP is not the same as IP ARP. IP ARP maps IP addresses (Layer 3) to Ethernet MAC addresses (Layer 2); LE ARP maps ELAN MAC addresses (Layer 2) to ATM addresses (also Layer 2).

When a LEC first joins an ELAN, its LE ARP table has no dynamic entries, and the LEC has no information about destinations on or behind its ELAN. To learn about a destination when a packet is to be sent, the LEC follows this process to find the ATM address corresponding to the known MAC address:

- 1 The LEC sends an LE ARP request to the LES for its ELAN (point-to-point Control Direct VCC, link 1–7 in Figure 35-2).
- 2 If the MAC address is registered with the LES, the LES returns the corresponding ATM address. If not, the LES forwards the LE ARP request to all LECs on the ELAN (point-to-multipoint Control Distribute VCC, link 2–8 in Figure 35-2).

- 3 Any LEC that recognizes the MAC address responds with its ATM address (point-to-point Control Direct VCC, link 1–7 in Figure 35-2).
- 4 The LES forwards the response (point-to-multipoint Control Distribute VCC, link 2–8 in Figure 35-2).
- 5 The LEC adds the MAC address-ATM address pair to its LE ARP cache.
- 6 The LEC establishes a VCC to the desired destination and transmits packets to that ATM address (bidirectional, point-to-point Data Direct VCC, link 6–6 in Figure 35-2).

For unknown destinations, the LEC sends a packet to the BUS, which forwards the packet to all LECs. The BUS floods the packet because the destination might be behind a bridge that has not yet learned this particular address.

Sending Multicast Traffic

When a LEC sends broadcast, multicast, or unicast traffic with an unknown address, the following process occurs:

- The LEC sends the packet to the BUS (unidirectional, point-to-point Multicast Send VCC, link 4–9 in Figure 35-2).
- The BUS floods the packet to all LECs (unidirectional, point-to-multipoint Multicast Forward VCC, link 5–10 in Figure 35-2). This VCC branches at each switch. The switch forwards such packets to multiple outputs. (The switch does not examine the MAC addresses; it simply forwards all packets it receives.)

LANE ATM Addressing Structure

On a LAN, packets are addressed using the MAC-layer addresses of the destination and source stations. To provide similar functionality for LANE, MAC-layer addressing must be supported. Every LEC must have a MAC address. In addition, every LANE component (LECS, LES, BUS, and LEC) must have a unique ATM address.

All LECs on the same interface have the same automatically assigned MAC address. That MAC address is also used as the end-system identifier (ESI) part of the ATM address. Although LEC MAC addresses are not unique, all ATM addresses are unique.

A LANE ATM address has the same syntax as an NSAP, but it is not a network-level address. It consists of the following:

- A 13-byte prefix that includes the following fields defined by the ATM Forum:
 - Authority and Format Identifier (AFI) field (1 byte)
 - Data Country Code (DCC) or International Code Designator (ICD) field (2 bytes)
 - Domain Specific Part Format Identifier (DFI) field (1 byte)
 - Administrative Authority field (3 bytes)
 - Reserved field (2 bytes)
 - Routing Domain field (2 bytes)
 - Area field (2 bytes)
- A 6-byte end-system
- A 1-byte selector field

Assigning ATM Addresses Automatically

Cisco provides the following method of constructing and assigning ATM and MAC addresses in a LECS database. A pool of 16 MAC addresses is assigned to each ATM module. For constructing ATM addresses, the following assignments are made to the LANE components:

- The prefix fields are the same for all LANE components in routers and the Catalyst 5000 series ATM modules; the prefix indicates the identity of the ATM switch. You might need to configure the prefix value on the ATM switch.
- The ESI field value assigned to every LEC on the interface is the first pool of MAC addresses assigned to the interface.
- The ESI field value assigned to every LES on the interface is the second pool of MAC addresses.
- The ESI field value assigned to the BUS on the interface is the third pool of MAC addresses.
- The ESI field value assigned to the LECS is the fourth pool of MAC addresses.
- The selector field value is set to the subinterface number (in hexadecimal notation) of the LANE component—except for the LECS, which has a selector field value of 00.

Because LANE components are defined on different subinterfaces of an ATM interface, the value of the selector field in an ATM address is different for each component. The result is a unique ATM address for each LANE component, even within the same Catalyst 5000 series switch. For more information about assigning components to subinterfaces, see the “ATM LANE Configuration Guidelines” section on page 35-9.

For example, if the MAC addresses assigned to an interface are 0800.200C.1000 through 0800.200C.100F, the ESI portion of the ATM addresses is assigned to LANE components as follows:

- Any LEC gets the ESI 0800.200c.1000.
- Any LES gets the ESI 0800.200c.1001.
- The BUS gets the ESI 0800.200c.1002.
- The LECS gets the ESI 0800.200c.1003.

Registering ILMI Addresses

The Catalyst 5000 series switch builds its ATM address by obtaining its ATM address prefix from the ATM switch. It combines the ATM address prefix with its own MAC address and the LEC subinterface number. After the ATM module determines its ATM address, it uses ILMI registration to register this address with the ATM switch. ILMI and signaling PVCs are set up by default.

Using the **atm vc-per-vp** command, you can configure the maximum number of virtual channel identifiers (VCIs) per virtual path identifier (VPI). If this value is configured when the ATM module registers with the ATM switch, the maximum number of VCIs per VPI is passed to the ATM switch. In this way, the ATM switch assigns to the Catalyst 5000 series switch a VCI value for a switched virtual circuit (SVC) that is within the ATM switch range. The default is 10 VCI bits and 2 VPI bits on the ATM module. Any change from the default requires an ATM module reset.

Using VTP to Create LECs Automatically

You can configure the Catalyst 5000 series switch and the ATM modules to use VTP to create LECs automatically when VLANs are created on the Catalyst 5000 series switch.

You must enable VTP on the ATM module and configure the LES/BUS and the LECS database for each VLAN/ELAN. LECs are created automatically based on the VTP mode of the switch in which the ATM module is installed:

- If the Catalyst 5000 series switch is in VTP transparent mode, when you create a VLAN on the switch, a LEC is created automatically on all ATM modules installed in that switch.
- If the switch belongs to a VTP domain, when you create a VLAN on the switch, a LEC is created automatically on all ATM modules installed in all switches belonging to the same VTP domain.

For information about creating LECs automatically using VTP, see the “Creating LECs Automatically Using VTP” section on page 35-24.

Drafting an ATM LANE Implementation Plan

Before implementing LANE, create a LANE plan for your own LANE scenario. Determine the LANE components you want to use, their locations, their associated VLANs, and the necessary redundancy features. Note the ATM address of each LANE component on each subinterface of each participating device.

Your plan should include the following information:

- How many ELANs you will create, and whether they will be unrestricted or restricted membership ELANs
- The VLAN to which each ELAN maps
- The ELAN that will function as the default ELAN in the LECS database (optional)
- The device and interface where the LECS will be located
- The device, interface, and subinterface where the LES/BUS for each ELAN will be located
- The devices and subinterfaces where the LECs for each ELAN will be located

Default ATM LANE Configuration

Table 35-1 shows the ATM LANE default configuration.

Table 35-1 ATM LANE Default Configuration

Feature	Default Value
LANE components	<ul style="list-style-type: none">• No LECS database is configured• No LES/BUS is configured• No LECs are configured
PVCs	ILMI and signaling PVCs are set up
Preferred PHY (dual PHY modules only)	PHY A
Output throttling	Disabled
ILMI keepalives	Disabled
UNI version	Autonegotiate (reverts to UNI 3.0 if autonegotiation fails)
VTP	Disabled

ATM LANE Configuration Guidelines

These guidelines apply when configuring LANE:

- The LECS is always assigned to the major interface. Assigning any other component to the major interface is identical to assigning that component to the 0 subinterface.
- The LES/BUS and the LEC of the *same* ELAN can be configured on the same subinterface.
- LECs of two *different* ELANs cannot be configured on the same subinterface.
- The LES/BUS for *different* ELANs cannot be configured on the same subinterface.
- All ATM switches have identical lists of the global LECS addresses with the identical priorities.
- The operating LECSs must use exactly the same configuration database. Create and maintain a configuration file containing the LECS database and load it onto devices using the **config net** command. This method minimizes errors and allows you to maintain the database centrally.
- The LANE subsystem supports up to 16 LECS addresses.
- The number of LES/BUSs that can be defined per ELAN is unlimited.
- When a LECS switchover occurs, no previously joined clients are affected.
- In a LES/BUS switchover, there is a momentary loss of clients until all clients are transferred to the new LES/BUS.
- LECSs come up as masters automatically until a higher level LECS tells them otherwise.
- You can configure redundant LES/BUSs and LECSs to reduce the likelihood of a server failure resulting in loss of communication on the LANE network. With redundant LES/BUSs and LECSs, LANE components can switch to the backup LES/BUS or LECS automatically if the primary server fails.

Note LES/BUS/LECS redundancy works only with LECS and LES/BUS combinations on Cisco devices. Third-party LANE components interoperate with the LECS and LES/BUS functions of Cisco devices but cannot take advantage of the redundancy features.

- With multiple LES/BUSs configured for a single ELAN, the priority of a given LES/BUS is established by the order in which it was entered in the LECS database. When a higher priority LES/BUS comes online, it takes over the functions of the current LES/BUS on the ELAN. For a short time after a power on, some LECs might change from one LES/BUS to another, depending upon the order in which the LES/BUSs come online.
- If no specified LES/BUS is up or connected to the master LECS, and more than one LES/BUS is defined for an ELAN, the LECS rejects any configuration request for that specific ELAN.
- Changes made to the list of LECS addresses on ATM switches can take up to one minute to propagate through the network. Changes made to the configuration database regarding LES/BUS addresses take effect almost immediately.
- If no designated LECS is operational or reachable, the ATM Forum-defined “well-known” LECS address is used.

- The LECS can be overridden on any subinterface by entering these commands:
 - **lane auto-config-atm-address**
 - **lane fixed-config-atm-address**
 - **lane config-atm-address** *atm-address-template*

Note To avoid affecting LES/BUS/LEC redundancy, do not override any LECS, LES, or BUS addresses.

- In the event of an ATM network failure, there can be multiple master LECs and multiple active LES/BUSs for the same ELAN, resulting in a partitioned network. Clients continue to operate normally, but transmission between different partitions of the network is not possible. The system recovers when the network break is repaired.

Configuring ATM LANE

These sections describe how to configure ATM LANE on the Catalyst 5000 series ATM modules:

- Opening a Session From the Switch to the ATM Module on page 35-10
- Specifying the Preferred PHY (Dual PHY Modules) on page 35-11
- Displaying Default ATM Addresses on page 35-11
- Configuring LECS ATM Addresses on a LightStream 1010 ATM Switch on page 35-12
- Setting Up the LES/BUS for an ELAN on page 35-13
- Setting Up a LEC for an ELAN on page 35-14
- Configuring the LECS Database on page 35-16
- Binding the LECS to the ATM Interface on page 35-22
- Monitoring and Maintaining LANE on page 35-23

Opening a Session From the Switch to the ATM Module

Use the **session mod_num** command to open a session to the ATM module from the Catalyst 5000 series switch in which the module is installed.

This example shows how to session to an ATM module installed in slot 5 of the Catalyst 5000 series switch:

```
Console> (enable) session 5
Trying ATM-5...
Connected to ATM-5.
Escape character is '^]'.

ATM>
```

After opening the session, you see the ATM> prompt. You then have direct access only to the ATM module with which you have established a session.

The ATM module uses a subset of Cisco IOS software. Generally, Cisco IOS software works the same on the ATM module as it does on routers. For more information, refer to the “ATM Module Command-Line Interface” section on page 2-7.

To configure the ATM module, you must use configuration mode. To enter configuration mode, enter the EXEC command **configure** at the privileged EXEC prompt (ATM#). You see the following message, which asks you to specify the terminal, the nonvolatile RAM (NVRAM), or a file stored on a network server as the source of configuration commands:

```
Configuring from terminal, memory, or network [terminal]?
```

Note You cannot configure from the network on the ATM modules.

Terminal configuration means changing the running configuration. You can save the running configuration into the NVRAM using the **copy running-config startup-config** command. When you configure from memory, the running configuration is updated from the NVRAM.

Specifying the Preferred PHY (Dual PHY Modules)

The Catalyst 5000 series dual physical-sublayer (dual PHY) ATM modules provide one active connection and one standby connection to the ATM network. You can connect both PHYs to a single ATM switch, or you can connect one PHY to one ATM switch and one PHY to a second ATM switch.

Only one PHY is active at any given time. If the active PHY loses its connection, the ATM module switches automatically to the standby PHY. PHY A is the preferred PHY by default. You can change the preferred PHY using the **atm preferred phy** interface configuration command.

To change the preferred PHY on the dual PHY ATM modules, perform this task in interface configuration mode:

Task	Command
Change the preferred PHY to the one not currently in use.	atm preferred phy {A B}

This example shows how to change the preferred PHY to PHY B:

```
ATM#configure terminal
Enter configuration commands, one per line. End with CNTL/Z.
ATM(config)#interface atm0
ATM(config-if)#atm preferred phy B
ATM(config-if)#^Z
ATM#
```

Displaying Default ATM Addresses

To help you configure the LECS database and the LECS addresses on the ATM switch, default ATM addresses for the LECS, LES, BUS, and LECs are automatically generated on the ATM module based on the ATM address prefix learned from the switch and the MAC address of the ATM module. (For more information about the LANE default ATM addresses, see the “Assigning ATM Addresses Automatically” section on page 35-7.) Use one of these procedures to display the default ATM addresses on the ATM module.

If the ATM module (single PHY or dual PHY) is connected to a single ATM switch, you can display the default ATM addresses by performing this task:

Task	Command
Display default ATM addresses. (Record the addresses for later use.)	show lane default-atm-addresses

This example shows how to display the default ATM addresses on an ATM LANE module:

```
ATM#show lane default-atm-addresses
interface ATM0:
LANE Client:      47.00918100000000E04FACB401.00E04FACB070.**
LANE Server:      47.00918100000000E04FACB401.00E04FACB071.**
LANE Bus:         47.00918100000000E04FACB401.00E04FACB072.**
LANE Config Server: 47.00918100000000E04FACB401.00E04FACB073.00
note: ** is the subinterface number byte in hex

ATM#
```

If the ATM LANE module does not learn the ATM address prefix, ensure that the module is connected to the switch properly, that the interfaces on both the ATM module and the ATM switch are up, and that the ILMI PVC is established (use the **show atm vc** command to see configured PVCs).

This example shows that the ATM module could not learn the ATM address prefix from the ATM switch through ILMI:

```
ATM#show lane default-atm-addresses
interface ATM0:
LANE Client:      ...00E04FACB070.**
LANE Server:      ...00E04FACB071.**
LANE Bus:         ...00E04FACB072.**
LANE Config Server: ...00E04FACB073.00
note: ** is the subinterface number byte in hex

ATM#
```

If the ATM module (dual PHY) is connected to two different ATM switches, you must determine the default ATM addresses to use for both PHYs.

To display the default ATM addresses on a dual PHY module connected to two different ATM switches, perform this task:

Task	Command
Step 1 Display the default ATM addresses for the first PHY.	show lane default-atm-addresses
Step 2 Enter configuration mode.	configure terminal
Step 3 Enter interface configuration mode.	interface atm0
Step 4 Change the preferred PHY to the one not currently in use.	atm preferred phy {A B}
Step 5 Exit configuration mode.	Ctrl-Z
Step 6 Display the default ATM addresses for the second PHY.	show lane default-atm-addresses

Configuring LECS ATM Addresses on a LightStream 1010 ATM Switch

You must program all LECS addresses into each ATM switch (such as a LightStream 1010 switch) connected to an ATM module in your LANE network. Programming the LECS addresses allows the LESs and LECs to determine the LECs addresses dynamically through ILMI.

To configure a LECS ATM address on a LightStream 1010 ATM switch, perform this task in privileged mode for each connected LightStream 1010 ATM switch:

Task	Command
Step 1 Enter configuration mode.	configure terminal
Step 2 Enter the address of the LECS.	atm lecs-address-default <i>lecs_atm_address</i>
Step 3 Exit configuration mode.	Ctrl-Z
Step 4 Verify the configured LECS addresses.	show atm ilmi-configuration

This example shows how to configure a LECS address on the LightStream 1010 ATM switch and verify the configuration:

```
Switch#configure terminal
Enter configuration commands, one per line. End with CNTL/Z.
Switch(config)#atm lecs-address-default 47.0091.8100.0000.00e0.4fac.b401.0010.0daa.cc43.00
Switch(config)#^Z
Switch#show atm ilmi-configuration

LECS Address(es) :
    47.0091.8100.0000.00e0.4fac.b401.0010.0daa.cc43.00
Switch#
```

Setting Up the LES/BUS for an ELAN

You must configure at least one LES/BUS for each ELAN in the ATM LANE network. The LES/BUS for each ELAN should be configured on a separate subinterface of the major ATM interface on the ATM module. The LES/BUS and the LEC of the same ELAN can be configured on the same subinterface. The LES/BUSs for different ELANs cannot be configured on the same subinterface.

You can configure redundant LES/BUSs for each ELAN. Typically, redundant LES/BUSs for a single ELAN should be configured on different ATM LANE modules in the LANE network. If you configure more than one LES/BUS for an ELAN, one LES/BUS takes precedence over others based on the order in which they are entered into the LECS database. If you configure a LES/BUS on a dual PHY ATM module, you must enter the default LECS ATM address for each PHY.



Caution If you plan to configure the ELAN in Step 3 for restricted membership, make sure the ELAN name you specify is exactly the same as the ELAN name specified in the LECS database. If the ELAN name specified in the **lane server-bus** command does not match the LECS database entry linking the LEC to an ELAN, the LEC is not allowed to join the ELAN.

To specify the LES/BUS for an ELAN, perform this task:

Task	Command
Step 1 Enter configuration mode.	configure terminal
Step 2 Specify the subinterface for the first ELAN.	interface atm 0. subinterface-number
Step 3 Enable the LES/BUS for an ELAN on the subinterface (you cannot configure more than one LES/BUS per subinterface).	lane server-bus ethernet elan-name
Step 4 Repeat Steps 2 and 3 for all LES/BUSs you want to configure on this ATM module.	
Step 5 Exit configuration mode.	Ctrl-Z
Step 6 Verify the LES/BUS configuration.	show lane server

Note The LES/BUSs are not fully operational until one or more LECs are configured and the LECS database is configured and bound to the ATM module interface.

This example shows how to specify the LES/BUS for an ELAN and verify the configuration:

```

ATM#configure terminal
Enter configuration commands, one per line. End with CNTL/Z.
ATM(config)#interface atm0.1
ATM(config-subif)#lane server-bus ethernet default
ATM(config-subif)#interface atm0.2
ATM(config-subif)#lane server-bus ethernet Eng_ELAN
ATM(config-subif)#^Z
ATM#show lane server
LE Server ATM0.1 ELAN name: default Admin: up State: operational
type: ethernet Max Frame Size: 1516
ATM address: 47.00918100000000E04FACB401.00100DAACC41.01
LECS used: 47.007900000000000000000000.00A03E000001.00 NOT yet connected

LE Server ATM0.2 ELAN name: Eng_ELAN Admin: up State: operational
type: ethernet Max Frame Size: 1516
ATM address: 47.00918100000000E04FACB401.00100DAACC41.02
LECS used: 47.007900000000000000000000.00A03E000001.00 NOT yet connected

ATM#
    
```

Setting Up a LEC for an ELAN

LECs serve to pass traffic between VLANs on the Catalyst 5000 series switch and ELANs in the ATM network. You can configure one or more LECs for one or more ELANs on the Catalyst 5000 series ATM modules.

Before you set up a LEC on the ATM module, you must configure a VLAN on the switch and the LES/BUS for an ELAN on an ATM module subinterface. When you configure a LEC on the ATM module, you map a VLAN on the Catalyst 5000 series switch to an ATM ELAN. For information on configuring VLANs on the Catalyst 5000 series supervisor engine, see Chapter 10, “Configuring VLANs.” For information on configuring the LES/BUS for an ELAN, see the “Setting Up the LES/BUS for an ELAN” section on page 35-13.

Note Using the VLAN Trunk Protocol (VTP), you can cause LECs to be created automatically when you configure VLANs on the Catalyst 5000 series supervisor engine. For more information on using VTP to create LECs automatically, see the “Creating LECs Automatically Using VTP” section on page 35-24.

Note If you later want to associate a LEC with a different ELAN, change the LECS database configuration before you change the LEC configuration on the subinterface. For information on configuring the LECS database, see the “Configuring the LECS Database” section on page 35-16.

To set up a LEC for an ELAN, perform this task:

Task	Command
Step 1 Enter configuration mode.	configure terminal
Step 2 Specify a subinterface for the LEC.	interface atm 0.subinterface
Step 3 Create the LEC, specifying the VLAN number and the ELAN name to which to bind the LEC.	lane client ethernet vlan_id elan-name
Step 4 Repeat Steps 2 and 3 for each LEC you want to configure.	
Step 5 Exit configuration mode.	Ctrl-Z
Step 6 Verify the LEC configuration.	show lane client

Note The LECs do not come up until the LES/BUSs are configured and the LECS database is configured and bound to the ATM module interface.

This example shows how to configure LECs and verify the configuration:

```

ATM#configure terminal
Enter configuration commands, one per line. End with CNTL/Z.
ATM(config)#interface atm0.1
ATM(config-subif)#lane client ethernet 1 default
ATM(config-subif)#interface atm0.2
ATM(config-subif)#lane client ethernet 2 Eng_ELAN
ATM(config-subif)#^Z
ATM#show lane client
LE Client ATM0.1 ELAN name: default Admin: up State: initialState
Client ID: unassigned Next join attempt in 0 seconds
Join Attempt: 4
Last Fail Reason: Config VC being released
HW Address: 0010.0daa.cc40 Type: ethernet Max Frame Size: 1516
VLANID: 1
ATM Address: 47.00918100000000E04FACB401.00100DAACC40.01

VCD  rxFrames  txFrames  Type      ATM Address
0      0          0  configure 47.0079000000000000000000000000.00A03E000001.00
0      0          0  direct   00.00000000000000000000000000.000000000000.00
0      0          0  distribute 00.00000000000000000000000000.000000000000.00
0      0          0  send     00.00000000000000000000000000.000000000000.00
0      0          0  forward  00.00000000000000000000000000.000000000000.00

LE Client ATM0.2 ELAN name: Eng_ELAN Admin: up State: initialState
Client ID: unassigned Next join attempt in 1 seconds

```

```
Join Attempt: 2
Last Fail Reason: Config VC being released
HW Address: 0010.0daa.cc40   Type: ethernet           Max Frame Size: 1516
          VLANID: 2
ATM Address: 47.00918100000000E04FACB401.00100DAACC40.02

VCD  rxFrames  txFrames  Type      ATM Address
    0         0         0  configure 47.0079000000000000000000000000.00A03E000001.00
VCD  rxFrames  txFrames  Type      ATM Address
    0         0         0  direct   00.0000000000000000000000000000.000000000000.00
    0         0         0  distribute 00.0000000000000000000000000000.000000000000.00
    0         0         0  send     00.0000000000000000000000000000.000000000000.00
    0         0         0  forward  00.0000000000000000000000000000.000000000000.00

ATM#
```

Configuring the LECS Database

The LECS database contains LANE configuration information, including ELAN name-to-LES/BUS ATM address mappings, LEC address-to-ELAN name mappings, and the name of the default ELAN, if specified. You must configure at least one LECS database in the ATM LANE network.

You can configure redundant LECSs. Redundant LECSs should be configured on different devices in the LANE network. If you configure more than one LECS, make sure that all databases with the same name are identical.

These sections describe how to set up the LECS database on the ATM module:

- Setting Up One (Default) ELAN in the LECS Database on page 35-16
- Setting Up Unrestricted-Membership ELANs in the LECS Database on page 35-18
- Setting Up Restricted-Membership ELANs in the LECS Database on page 35-19

Setting Up One (Default) ELAN in the LECS Database

When you configure a Catalyst 5000 series ATM module as the LECS for one default ELAN, you provide a name for the database, the ATM address of the LES/BUS for the ELAN, and the name of the default ELAN.

The default ELAN cannot be a restricted-membership ELAN. You do not need to specify the ATM or MAC addresses of the LECs for the default ELAN.

On the dual PHY ATM modules, you must configure redundant LES/BUS/LECS, one for each PHY.

Note Before beginning the LECS database configuration, make sure you have configured the LES/BUS and LEC for the default ELAN (see the “Setting Up the LES/BUS for an ELAN” section on page 35-13 and the “Setting Up a LEC for an ELAN” section on page 35-14).

To set up the LECS for one default ELAN, perform this task:

Task	Command
Step 1 Display the ATM address of the LES/BUS for the default ELAN.	show lane server
Step 2 Enter configuration mode.	configure terminal
Step 3 Enter database configuration mode, specifying a LANE database name.	lane database <i>database-name</i>
Step 4 Bind the name of the ELAN to the ATM address of the LES/BUS.	name <i>elan-name</i> server-atm-address <i>atm-address</i>
Step 5 In the configuration database, provide a default name of the ELAN.	default-name <i>elan-name</i>
Step 6 Exit from configuration mode.	Ctrl-Z
Step 7 Verify the LECS database configuration.	show lane database

Note After you configure the LECS database, you must bind the LECS database to the major ATM interface (ATM0) on the ATM module. For information on how to bind the database to the interface, see the “Binding the LECS to the ATM Interface” section on page 35-22.

This example shows how to display the ATM address of the LES/BUS of the default ELAN, how to configure the LECS database for the default ELAN, and how to verify the configuration:

```
ATM#show lane server
LE Server ATM0.1 ELAN name: default Admin: up State: operational
type: ethernet Max Frame Size: 1516
ATM address: 47.00918100000000E04FACB401.00100DAACC41.01
LECS used: 47.00790000000000000000000000.00A03E000001.00 NOT yet connected

ATM#configure terminal
Enter configuration commands, one per line. End with CNTL/Z.
ATM(config)#lane database LANE_Backbone
ATM(lane-config-database)#name default server-atm-address 47.00918100000000E04FACB401.00100DAACC41.01
ATM(lane-config-database)#default-name default
ATM(lane-config-database)#^Z
ATM#show lane database

LANE Config Server database table 'LANE_Backbone'
default elan: default
elan 'default': un-restricted
server 47.00918100000000E04FACB401.00100DAACC41.01 (prio 0)

ATM#
```

Setting Up Unrestricted-Membership ELANs in the LECS Database

When you configure unrestricted-membership ELANs in the LECS database, you create database entries that link the name of each ELAN to the ATM address of its LES/BUS. With unrestricted-membership ELANs, you do not need to specify the ATM or MAC addresses of the LECs for each ELAN. If desired, you can specify a default ELAN for LECs not bound to an ELAN explicitly.

Note Before beginning the LECS database configuration, make sure you have configured a LES/BUS and LEC for each ELAN (see the “Setting Up the LES/BUS for an ELAN” section on page 35-13 and the “Setting Up a LEC for an ELAN” section on page 35-14).

To configure unrestricted-membership ELANs in the LECS database, perform this task:

Task	Command
Step 1 Display the ATM addresses of the configured LES/BUSs.	show lane server [interface atm0 [.subinterface] name elan-name] [brief]
Step 2 Enter configuration mode.	configure terminal
Step 3 Enter database configuration mode, specifying a LANE database name.	lane database <i>database-name</i>
Step 4 Bind the ELAN name to the ATM address of the LES/BUS for that ELAN (use the ATM address displayed in the show lane server command output). Repeat this step for each ELAN in the LANE network.	name <i>elan-name</i> server-atm-address <i>atm-address</i>
Step 5 (Optional) Specify an ELAN as the default ELAN for LECs not bound to an ELAN explicitly.	default-name <i>elan-name</i>
Step 6 Exit from configuration mode.	Ctrl-Z
Step 7 Verify the LECS database configuration.	show lane database

Note After you configure the LECS database, you must bind the LECS database to the major ATM interface (ATM0) on the ATM module. For information on how to bind the database to the interface, see the “Binding the LECS to the ATM Interface” section on page 35-22.

This example shows how to display the ATM address of the LES/BUSs for all ELANs, how to configure the LECS database for each ELAN, how to specify a default ELAN, and how to verify the configuration:

```
ATM#show lane server
LE Server ATM0.1  ELAN name: default  Admin: up  State: operational
type: ethernet      Max Frame Size: 1516
ATM address: 47.00918100000000E04FACB401.00100DAACC41.01
LECS used: 47.00790000000000000000000000.00A03E000001.00 NOT yet connected

LE Server ATM0.2  ELAN name: Eng_ELAN  Admin: up  State: operational
type: ethernet      Max Frame Size: 1516
ATM address: 47.00918100000000E04FACB401.00100DAACC41.02
LECS used: 47.00790000000000000000000000.00A03E000001.00 NOT yet connected

LE Server ATM0.3  ELAN name: Mktg_ELAN  Admin: up  State: operational
type: ethernet      Max Frame Size: 1516
ATM address: 47.00918100000000E04FACB401.00100DAACC41.03
LECS used: 47.00790000000000000000000000.00A03E000001.00 NOT yet connected

ATM#configure terminal
Enter configuration commands, one per line.  End with CNTL/Z.
ATM(config)#lane database LANE_Backbone
ATM(lane-config-database)#name default server-atm-address 47.00918100000000E04FACB401.00100DAACC41.01
ATM(lane-config-database)#name Eng_ELAN server-atm-address 47.00918100000000E04FACB401.00100DAACC41.02
ATM(lane-config-database)#name Mktg_ELAN server-atm-address 47.00918100000000E04FACB401.00100DAACC41.03
ATM(lane-config-database)#default-name default
ATM(lane-config-database)#^Z
ATM#show lane database

LANE Config Server database table 'LANE_Backbone'
default elan: default
elan 'default': un-restricted
  server 47.00918100000000E04FACB401.00100DAACC41.01 (prio 0)
elan 'Eng_ELAN': un-restricted
  server 47.00918100000000E04FACB401.00100DAACC41.02 (prio 0)
elan 'Mktg_ELAN': un-restricted
  server 47.00918100000000E04FACB401.00100DAACC41.03 (prio 0)

ATM#
```

Setting Up Restricted-Membership ELANs in the LECS Database

When you configure restricted-membership ELANs in the LECS database, you create database entries that link the name of each ELAN to the ATM address of its LES/BUS. In addition, you must specify the ATM or MAC addresses of the LECs belonging to each ELAN. If desired, you can specify a default ELAN for LECs not bound to an ELAN explicitly. The default ELAN must be an unrestricted-membership ELAN.

If there are LECs for a given restricted-membership ELAN configured on multiple Catalyst 5000 series ATM modules, you must bind the ATM or MAC address of each LEC explicitly with the name of that ELAN using the **client-atm-address** database configuration command. For example, if you configure three LECs for a particular restricted-membership ELAN on three different ATM modules, you must configure three LECS database entries, one entry for each LEC. Each entry binds the ATM or MAC address of each LEC to the restricted-membership ELAN.

Note Before beginning the LECS database configuration, make sure you have configured a LES/BUS and LEC for each ELAN (see the “Setting Up the LES/BUS for an ELAN” section on page 35-13 and the “Setting Up a LEC for an ELAN” section on page 35-14).

To configure restricted-membership ELANs in the LECS database, perform this task:

Task	Command
Step 1 Display the ATM addresses of the configured LES/BUSs.	show lane server [interface atm0 [.subinterface] name elan-name] [brief]
Step 2 Display the ATM addresses of the configured LECs.	show lane client [interface atm0 [.subinterface] name elan-name] [brief]
Step 3 Enter configuration mode.	configure terminal
Step 4 Enter database configuration mode, specifying a LANE database name.	lane database <i>database-name</i>
Step 5 Bind the restricted-membership ELAN name to the ATM address of the LES/BUS for that ELAN. Repeat this step for every restricted-membership ELAN in the LANE network.	name <i>elan-name</i> server-atm-address <i>atm-address</i> restricted
Step 6 Bind a specific LEC ATM address with a specific restricted-membership ELAN. Repeat this step for every LEC belonging to the restricted-membership ELAN in the LANE network (including LECs configured on other ATM modules).	client-atm-address <i>atm-address</i> name <i>elan-name</i>
Step 7 (Optional) If you want to configure a default ELAN for LECs not bound to an ELAN explicitly, bind the default ELAN name to the ATM address of the LES/BUS for the default ELAN. The default ELAN must be an unrestricted-membership ELAN.	name <i>default-elan-name</i> server-atm-address <i>atm-address</i>
Step 8 (Optional) Specify the default ELAN.	default-name <i>default-elan-name</i>
Step 9 Exit from configuration mode.	Ctrl-Z
Step 10 Verify the LECS database configuration.	show lane database

Note After you configure the LECS database, you must bind the LECS database to the major ATM interface (ATM0) on the ATM module. For information on how to bind the database to the interface, see the “Binding the LECS to the ATM Interface” section on page 35-22.

This example shows how to display the ATM address of the LES/BUSs and LECs, how to configure the LECS database for restricted-membership ELANs, how to specify a default ELAN, and how to verify the configuration:

ATM#show lane server

```
LE Server ATM0.1 ELAN name: default Admin: up State: operational
type: ethernet Max Frame Size: 1516
ATM address: 47.00918100000000E04FACB401.00100DAACC41.01
LECS used: 47.00790000000000000000000000.00A03E000001.00 NOT yet connected
```

```
LE Server ATM0.2 ELAN name: Eng_ELAN Admin: up State: operational
type: ethernet Max Frame Size: 1516
ATM address: 47.00918100000000E04FACB401.00100DAACC41.02
LECS used: 47.00790000000000000000000000.00A03E000001.00 NOT yet connected
```

```
LE Server ATM0.3 ELAN name: Mktg_ELAN Admin: up State: operational
type: ethernet Max Frame Size: 1516
ATM address: 47.00918100000000E04FACB401.00100DAACC41.03
LECS used: 47.00790000000000000000000000.00A03E000001.00 NOT yet connected
```

ATM#show lane client brief

```
LE Client ATM0.1 ELAN name: default Admin: up State: initialState
Client ID: unassigned Next join attempt in 38 seconds
Join Attempt: 121
Last Fail Reason: Config VC being released
HW Address: 0010.0daa.cc40 Type: ethernet Max Frame Size: 1516
VLANID: 1
ATM Address: 47.00918100000000E04FACB401.00100DAACC40.01
```

```
LE Client ATM0.2 ELAN name: Eng_ELAN Admin: up State: initialState
Client ID: unassigned Next join attempt in 60 seconds
Join Attempt: 90
Last Fail Reason: Config VC being released
HW Address: 0010.0daa.cc40 Type: ethernet Max Frame Size: 1516
VLANID: 2
ATM Address: 47.00918100000000E04FACB401.00100DAACC40.02
```

```
LE Client ATM0.3 ELAN name: Mktg_ELAN Admin: up State: initialState
Client ID: unassigned Next join attempt in 39 seconds
Join Attempt: 89
Last Fail Reason: Config VC being released
HW Address: 0010.0daa.cc40 Type: ethernet Max Frame Size: 1516
VLANID: 3
ATM Address: 47.00918100000000E04FACB401.00100DAACC40.03
```

ATM#configure terminal

Enter configuration commands, one per line. End with CNTL/Z.

ATM(config)#lane database LANE_Backbone

ATM(lane-config-database)#name Eng_ELAN server-atm-address 47.00918100000000E04FACB401.00100DAACC41.02 restricted

ATM(lane-config-database)#name Mktg_ELAN server-atm-address 47.00918100000000E04FACB401.00100DAACC41.03 restricted

ATM(lane-config-database)#client-atm-address 47.00918100000000E04FACB401.00100DAACC40.02 name Eng_ELAN

ATM(lane-config-database)#client-atm-address 47.00918100000000E04FACB401.00100DAACC40.03 name Mktg_ELAN

ATM(lane-config-database)#name default server-atm-address 47.00918100000000E04FACB401.00100DAACC41.01

ATM(lane-config-database)#default-name default

ATM(lane-config-database)#^Z

ATM#show lane database

LANE Config Server database table 'LANE_Backbone'

default elan: default

elan 'Eng_ELAN': restricted

server 47.00918100000000E04FACB401.00100DAACC41.02 (prio 0)

```

atm client 47.00918100000000E04FACB401.00100DAACC40.02
elan 'Mktg_ELAN': restricted
  server 47.00918100000000E04FACB401.00100DAACC41.03 (prio 0)
  atm client 47.00918100000000E04FACB401.00100DAACC40.03
elan 'default': un-restricted
  server 47.00918100000000E04FACB401.00100DAACC41.01 (prio 0)

```

ATM#

Binding the LECS to the ATM Interface

Before LANE communication can occur, you must bind the LECS database to the major interface on the ATM module.

To bind the LECS database to the ATM module interface, perform this task:

Task	Command
Step 1 Enter configuration mode.	configure terminal
Step 2 Select the ATM interface.	interface atm0
Step 3 Specify the address of the LECS (use the auto-config-atm-address keyword to use the autogenerated LECS ATM address).	lane config { auto-config-atm-address config-atm-address lecs_atm_address }
Step 4 Bind the LECS database to the interface.	lane config database database-name
Step 5 Exit configuration mode.	Ctrl-Z
Step 6 Verify that the LECS is up and running.	show lane config

This example shows how to bind the autogenerated LECS ATM address and the LECS database to the major ATM interface and how to verify the configuration:

```

ATM#configure terminal
Enter configuration commands, one per line. End with CNTL/Z.
ATM(config)#interface atm0
ATM(config-if)#lane config auto-config-atm-address
ATM(config-if)#lane config database LANE_Backbone
ATM(config-if)#^Z
ATM#show lane config
LE Config Server ATM0 config table: LANE_Backbone
Admin: up State: operational
LECS Mastership State: active master
list of global LECS addresses (58 seconds to update):
47.00918100000000E04FACB401.00100DAACC43.00 <----- me
ATM Address of this LECS: 47.00918100000000E04FACB401.00100DAACC43.00 (auto)
vcd rxCnt txCnt callingParty
  5      0      0 47.00918100000000E04FACB401.00100DAACC41.03 LES Mktg_ELAN 0
active
  6      0      0 47.00918100000000E04FACB401.00100DAACC41.02 LES Eng_ELAN 0
active
 11     1      1 47.00918100000000E04FACB401.00100DAACC41.01 LES default 0
active
cumulative total number of unrecognized packets received so far: 0
cumulative total number of config requests received so far: 3
cumulative total number of config failures so far: 1
  cause of last failure: no configuration
  culprit for the last failure: 47.00918100000000E04FACB401.00E04FACB070.04

ATM#

```

Monitoring and Maintaining LANE

After configuring LANE components on the LANE module, you can display a variety of information on their status. To show LANE information, perform any of these tasks in user EXEC or privileged EXEC mode:

Task	Command
• Display complete LANE configuration and status information for LES/BUSs, LECs, and LECSs.	show lane
• Display the global and per-VCC LANE information for all the LANE components and ELANs configured on an interface or any of its subinterfaces.	show lane [interface atm0 [.subinterface-number] name elan-name] [brief]
• Display the global and per-VC LANE information for the LES configured on a specified subinterface or ELAN.	show lane server [interface atm0 [.subinterface-number] name elan-name] [brief]
• Display the global and per-VC LANE information for the BUS configured on any subinterface or ELAN.	show lane bus [interface atm0.subinterface-number] name elan-name] [brief]
• Display the global and per-VC LANE information for all LECs configured on any subinterface or ELAN.	show lane client [interface atm0 [.subinterface-number] name elan-name] [brief]
• Display the global and per-VC LANE information for the LECS configured on any interface.	show lane config
• Display the LECS database.	show lane database [database-name]
• Display the LE ARP table of the LECs configured on the specified subinterface or ELAN.	show lane le-arp [interface atm0 [.subinterface-number] name elan-name]
• Display ATM VC information.	show atm vc [vcd_number]

This example shows how to display brief information on all configured LANE components:

```
ATM#show lane brief
LE Server ATM0.1 ELAN name: default Admin: up State: operational
type: ethernet Max Frame Size: 1516
ATM address: 47.00918100000000E04FACB401.00100DAACC41.01
LECS used: 47.00918100000000E04FACB401.00100DAACC43.00 connected, vcd 12
control distribute: vcd 19, 3 members, 27723 packets

LE BUS ATM0.1 ELAN name: default Admin: up State: operational
type: ethernet Max Frame Size: 1516
ATM address: 47.00918100000000E04FACB401.00100DAACC42.01
data forward: vcd 23, 3 members, 174529 packets, 0 unicasts

LE Client ATM0.1 ELAN name: default Admin: up State: operational
Client ID: 1 LEC up for 15 hours 9 minutes 47 seconds
Join Attempt: 140
HW Address: 0010.0daa.cc40 Type: ethernet Max Frame Size: 1516
VLANID: 1
ATM Address: 47.00918100000000E04FACB401.00100DAACC40.01

LE Config Server ATM0 config table: LANE_Backbone
Admin: up State: operational
LECS Mastership State: active master
list of global LECS addresses:
47.00918100000000E04FACB401.00100DAACC43.00
ATM Address of this LECS: 47.00918100000000E04FACB401.00100DAACC43.00 (auto)

LE Server ATM0.2 ELAN name: Eng_ELAN Admin: up State: operational
type: ethernet Max Frame Size: 1516
```

```
ATM address: 47.00918100000000E04FACB401.00100DAACC41.02
LECS used: 47.00918100000000E04FACB401.00100DAACC43.00 connected, vcd 8
control distribute: vcd 31, 1 members, 27287 packets

LE BUS ATM0.2 ELAN name: Eng_ELAN Admin: up State: operational
type: ethernet Max Frame Size: 1516
ATM address: 47.00918100000000E04FACB401.00100DAACC42.02
data forward: vcd 35, 1 members, 28190 packets, 0 unicasts

LE Client ATM0.2 ELAN name: Eng_ELAN Admin: up State: operational
Client ID: 1 LEC up for 15 hours 9 minutes 34 seconds
Join Attempt: 109
HW Address: 0010.0daa.cc40 Type: ethernet Max Frame Size: 1516
VLANID: 2
ATM Address: 47.00918100000000E04FACB401.00100DAACC40.02

LE Server ATM0.3 ELAN name: Mktg_ELAN Admin: up State: operational
type: ethernet Max Frame Size: 1516
ATM address: 47.00918100000000E04FACB401.00100DAACC41.03
LECS used: 47.00918100000000E04FACB401.00100DAACC43.00 connected, vcd 7
control distribute: vcd 54, 1 members, 27250 packets

LE BUS ATM0.3 ELAN name: Mktg_ELAN Admin: up State: operational
type: ethernet Max Frame Size: 1516
ATM address: 47.00918100000000E04FACB401.00100DAACC42.03
data forward: vcd 58, 1 members, 28152 packets, 0 unicasts

LE Client ATM0.3 ELAN name: Mktg_ELAN Admin: up State: operational
Client ID: 1 LEC up for 15 hours 8 minutes 20 seconds
Join Attempt: 109
HW Address: 0010.0daa.cc40 Type: ethernet Max Frame Size: 1516
VLANID: 3
ATM Address: 47.00918100000000E04FACB401.00100DAACC40.03

ATM#
```

Creating LECs Automatically Using VTP

When you create and modify VLANs on a Catalyst 5000 series switch that belongs to a VTP domain, VTP automatically distributes VLAN configuration information over trunk links to all devices in the VTP domain. VTP is transmitted on all trunk connections, including ATM LANE.

By default, VTP is disabled on the Catalyst 5000 series switch ATM module. When you enable VTP on an ATM module, you can have ATM modules automatically create LECs for VLANs created on the Catalyst 5000 series switch.

You can use VTP to set up LECs in both VTP transparent and nontransparent (server or client) mode. If the Catalyst 5000 series switch is in VTP transparent mode, configuring a VLAN creates LECs on ATM modules installed only in the switch on which you configured the VLAN.

If the Catalyst 5000 series switch is in VTP server mode, configuring a VLAN creates LECs on all ATM modules on all Catalyst 5000 series switches in the same VTP domain (both clients and servers).

Note You might need to reload the ATM module after you configure VTP for VTP creation of LECs to take effect.

Automatic creation of LECs using VTP is supported in Catalyst 5000 series software release 2.1 or later with ATM module software release 3.1 or later.

This procedure describes how to configure the Catalyst 5000 series switch and the ATM module so that when you create a VLAN on the switch, LECs are created on all ATM modules in all switches in the VTP domain (in VTP transparent mode, only ATM modules on the local switch are affected):

Step 1 Configure a VTP domain on the Catalyst 5000 series switches. Every switch with an ATM module on which you want LECs created automatically must belong to the same VTP domain. For information on configuring VTP, see Chapter 9, “Configuring VTP.”

Step 2 Enable VTP on the ATM module. You must enable VTP on every ATM module on which you want LECs created automatically. For information on enabling VTP on the ATM module, see the “Configuring VTP on the ATM Module” section on page 35-26.

Step 3 Configure at least one LES/BUS for each VLAN/ELAN you will configure. VTP does *not* create or configure the LES/BUS for VLANs/ELANs.

VTP cannot create the LECs automatically unless one or more LES/BUSs are configured for each VLAN/ELAN. The ELAN name for VLAN 1 *must* be “default.” For information on configuring the LES/BUS, see the “Setting Up the LES/BUS for an ELAN” section on page 35-13.

Step 4 Configure the LECS database with ELAN name-to-LES/BUS mappings for all VLANs/ELANs you will configure. VTP does *not* create or configure the LECS database. Use the name of the VTP domain configured on the Catalyst 5000 series switch as the LECS database name.

VTP cannot create the LECs automatically unless the LECS database is configured properly. LECs can be created automatically by VTP *only* in unrestricted-membership ELANs. In addition, the ELAN name for VLAN 1 *must* be “default.” For information on configuring the LECS database, see the “Configuring the LECS Database” section on page 35-16.

Step 5 Bind the LECS database to the ATM interface on the ATM module. For information on binding the LECS database to the ATM interface, see the “Binding the LECS to the ATM Interface” section on page 35-22.

Step 6 At the Catalyst 5000 series switch CLI, create the desired VLANs. Ensure that the VLAN name matches the ELAN name configured in the LECS database on the ATM module. The name for VLAN 1 is “default” and cannot be changed. The corresponding ELAN name on the ATM module must be “default” also.

For VTP to successfully set up LECs on all ATM modules in the ATM LANE network, the default VLAN/ELAN must be operational on the ATM modules and Catalyst 5000 series switches and must be named “default.” If you currently have a different ELAN name mapped to VLAN 1, you must change the ELAN name to “default” in the LECS database.

When you enter the **set vlan** command without specifying the VLAN name, the VLAN names listed in Table 35-2 are used by default.

Table 35-2 Default ELAN Names

VLAN Number	ELAN Name
1	default
2	VLAN0002
3	VLAN0003

Table 35-2 Default ELAN Names (continued)

VLAN Number	ELAN Name
4	VLAN0004
5	VLAN0005
...1005	...VLAN1005

For information on configuring VLANs, see Chapter 10, “Configuring VLANs.”

Configuring General ATM Parameters

These sections describe how to configure general parameters on the ATM module that are not specific to ATM LANE:

- Configuring VTP on the ATM Module on page 35-26
- Configuring Output Throttling on page 35-27
- Configuring ILMI Keepalives on page 35-27
- Configuring the UNI Signaling Version on page 35-28

Configuring VTP on the ATM Module

To enable VTP on the ATM module, perform this task:

Task	Command
Step 1 Enter configuration mode.	configure terminal
Step 2 Enable VTP on the ATM module.	vtp enable
Step 3 Exit configuration mode.	Ctrl-Z

This example shows how to enable VTP on the ATM module:

```
ATM#configure terminal
Enter configuration commands, one per line. End with CNTL/Z.
ATM(config)#vtp enable
ATM(config)#^Z
ATM#
```

To disable VTP on the ATM module, perform this task:

Task	Command
Step 1 Enter configuration mode.	configure terminal
Step 2 Disable VTP on the ATM module.	no vtp enable
Step 3 Exit configuration mode.	Ctrl-Z

This example shows how to disable VTP on the ATM module:

```
ATM#configure terminal
Enter configuration commands, one per line. End with CNTL/Z.
ATM(config)#no vtp enable
ATM(config)#^Z
ATM#
```

Configuring Output Throttling

You can configure output throttling on the Catalyst 5000 series switch ATM module to control the transmission rate on the ATM interface. Output throttling applies to both LANE and PVCs. Per-VC pacing is not supported.

To throttle the output of the entire interface, perform this task:

Task	Command
Step 1 Enter configuration mode.	configure terminal
Step 2 Select the ATM interface.	interface atm0
Step 3 Apply output throttling to the interface.	atm traffic-shape rate <i>peak_rate</i>
Step 4 Exit configuration mode.	Ctrl-Z

This example shows how to throttle the output of the ATM module interface to 100 Mbps:

```
ATM#configure terminal
Enter configuration commands, one per line. End with CNTL/Z.
ATM(config)#interface atm0
ATM(config-if)#atm traffic-shape rate 100
ATM(config-if)#^Z
ATM#
```

To return the output rate to the default value for the interface, perform this task:

Task	Command
Step 1 Enter configuration mode.	configure terminal
Step 2 Select the ATM interface.	interface atm0
Step 3 Apply output throttling to the interface.	no atm traffic-shape rate <i>peak_rate</i>
Step 4 Exit configuration mode.	Ctrl-Z

This example shows how to return the output of the ATM module interface to the default value:

```
ATM#configure terminal
Enter configuration commands, one per line. End with CNTL/Z.
ATM(config)#interface atm0
ATM(config-if)#no atm traffic-shape rate 100
ATM(config-if)#^Z
ATM#
```

Configuring ILMI Keepalives

When you enable Integrated Local Management Interface (ILMI) keepalives on a dual PHY ATM module, periodic ILMI keepalive messages are sent to the ATM switch on the active PHY. The ATM switch responds to the ILMI keepalives.

If the ATM switch fails to respond to four consecutive keepalives, the dual PHY module switches from the active PHY to the backup PHY. The ILMI keepalives feature is useful only if the dual PHY module is connected to two different ATM switches. ILMI keepalives are disabled by default.

To enable ILMI keepalives and configure the interval between messages, perform this task:

Task	Command
Step 1 Enter configuration mode.	configure terminal
Step 2 Select the ATM interface.	interface atm0
Step 3 Enable ILMI keepalives and specify the message interval.	atm ilmi-keepalive [interval]
Step 4 Exit configuration mode.	Ctrl-Z
Step 5 Verify the output rate for the interface.	show interface atm0

This example shows how to enable ILMI keepalives and configure the interval between messages to four seconds:

```
ATM#configure terminal
Enter configuration commands, one per line. End with CNTL/Z.
ATM(config)#interface atm0
ATM(config-if)#atm ilmi-keepalive 4
ATM(config-if)#^Z
ATM#
```

To disable ILMI keepalives and configure the interval between messages, perform this task:

Task	Command
Step 1 Enter configuration mode.	configure terminal
Step 2 Select the ATM interface.	interface atm0
Step 3 Disable ILMI keepalives and specify the message interval.	no atm ilmi-keepalive
Step 4 Exit configuration mode.	Ctrl-Z

This example shows how to disable ILMI keepalives on the ATM module:

```
ATM#configure terminal
Enter configuration commands, one per line. End with CNTL/Z.
ATM(config)#interface atm0
ATM(config-if)#no atm ilmi-keepalive
ATM(config-if)#^Z
ATM#
```

Configuring the UNI Signaling Version

The ATM modules are backward-compatible with ATM switches that support User-Network Interface (UNI) version 3.0. When the ATM module comes online, ILMI negotiates between the UNI version automatically.

If the UNI version is successfully learned through ILMI, the ATM module accepts the UNI version returned from the ATM switch. If ILMI is unable to determine the UNI version, or if ILMI is disabled, the UNI version defaults to version 3.0.

To statically configure the UNI version, perform this task:

Task	Command
Step 1 Enter configuration mode.	configure terminal
Step 2 Select the ATM interface.	interface atm0

Task	Command
Step 3 Shut down the interface.	shutdown
Step 4 Statically configure the UNI version for the ATM interface.	atm uni-version {3.0 3.1}
Step 5 Bring up the interface.	no shutdown
Step 6 Exit configuration mode.	Ctrl-Z
Step 7 Verify the UNI version.	show interface atm0

This example shows how to statically configure the UNI version to version 3.0 and verify the configuration:

```

ATM#configure terminal
Enter configuration commands, one per line. End with CNTL/Z.
ATM(config)#interface atm0
ATM(config-if)#shutdown
ATM(config-if)#atm uni-version 3.0
ATM(config-if)#no shutdown
ATM(config-if)#^Z
ATM#show interface atm0
ATM0 is up, line protocol is up
  Hardware is Catalyst 5000 ATM
  MTU 1500 bytes, sub MTU 0, BW 156250 Kbit, DLY 80 usec, rely 255/255, load 1/2
55
  Encapsulation ATM, loopback not set, keepalive not supported
  Encapsulation(s): AAL5, PVC mode
  4096 maximum active VCs, 1024 VCs per VP, 32 current VCCs
  VC idle disconnect time: 300 seconds
  Signalling vc = 1, vpi = 0, vci = 5
  UNI Version = 3.0, Link Side = user
  PHY Type : SINGLE PHY;          Link Status: UP
  Last input 00:00:00, output never, output hang never
  Last clearing of "show interface" counters never
  Queueing strategy: fifo
  Output queue 0/40, 0 drops; input queue 0/75, 0 drops
  5 minute input rate 1000 bits/sec, 1 packets/sec
  5 minute output rate 1000 bits/sec, 1 packets/sec
    870851 packets input, 116131392 bytes, 0 no buffer
    Received 0 broadcasts, 0 runts, 0 giants, 0 throttles
    0 input errors, 0 CRC, 0 frame, 0 overrun, 0 ignored, 0 abort
    705922 packets output, 83530944 bytes, 0 underruns
    0 output errors, 0 collisions, 8 interface resets
    0 output buffer failures, 0 output buffers swapped out
ATM#

```

To return the UNI version to the default (either the version returned by ILMI or UNI version 3.0, if ILMI cannot learn the UNI version or if ILMI is disabled), perform this task:

Task	Command
Step 1 Enter configuration mode.	configure terminal
Step 2 Select the ATM interface.	interface atm0
Step 3 Shut down the interface.	shutdown
Step 4 Restore the default UNI version for the ATM interface (learned through ILMI or version 3.0 if ILMI cannot learn the UNI version).	no atm uni-version
Step 5 Bring up the interface.	no shutdown

Task	Command
Step 6 Exit configuration mode.	Ctrl-Z
Step 7 Verify the UNI version.	show interface atm0

This example shows how to return the UNI version on the ATM interface to the default:

```

ATM#configure terminal
Enter configuration commands, one per line. End with CNTL/Z.
ATM(config)#interface atm0
ATM(config-if)#shutdown
ATM(config-if)#no atm uni-version
ATM(config-if)#no shutdown
ATM(config-if)#^Z
ATM#
    
```

ATM LANE Configuration Examples

These sections show examples of how to configure ATM LANE on a Catalyst 5000 series ATM module:

- Example Configuration 1 on page 35-30
- Example Configuration 2 on page 35-34
- Example Configuration 3 on page 35-38

Example Configuration 1

Figure 35-3 shows a configuration of two Catalyst 5000 series switches (Catalyst 5000 series Switch 1 and Catalyst 5000 series Switch 2) and a LightStream 1010 ATM switch.

Figure 35-3 LES/BUS/LECS Configuration

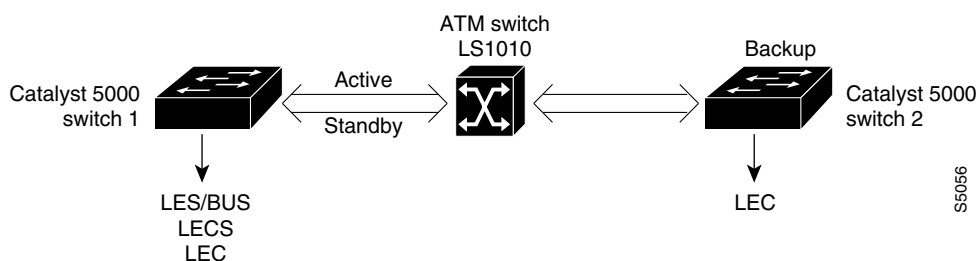

Example Configuration 1 Assumptions

In example configuration 1, these assumptions apply:

- The LightStream 1010 ATM switch is used.
- Catalyst 5000 series switches with the ATM modules installed are running ATM software release 3.1 or later.
- Catalyst 5000 series Switch 1 runs the LES/BUS and LECS on interface atm0 and the LEC on interface atm0.1.

- Catalyst 5000 series Switch 2 runs LEC on interface atm0.1.
- The ATM module is installed in slot 4 of both Catalyst 5000 series switches.
- You can change the ELAN name by entering the **set vlan vlan_num [name elan_name]** command.
- The ELAN names shown in Table 35-3 are used.

Table 35-3 ELAN Names

VLAN Number	ELAN Name
1	default
2	VLAN0002
3	VLAN0003
4	VLAN0004

Example Configuration 1 Procedure

To set up LANE on the configuration in Figure 35-3, perform these steps:

- Step 1** Set up the prefix of the ATM Network Service Access Point (NSAP) address for the switch.

The LightStream 1010 ATM switch provides a default prefix.

- Step 2** Start a session to the ATM module by entering the **session 4** command. You see this display:

```
Console> session 4
Trying ATM-4...
Connected to ATM-4.
Escape character is '^]'.
ATM>
```

- Step 3** Obtain the LES and LES/BUS addresses for later use by entering the **enable** command (to enable configuration mode) and the **show lane default** command at the ATM prompt. You see this display:

```
ATM>enable
ATM#
ATM#show lane default
interface ATM0:
LANE Client:      47.0091810000000061705b7701.00400BFF0010.**
LANE Server:     47.0091810000000061705b7701.00400BFF0011.**
LANE Bus:        47.0091810000000061705b7701.00400BFF0012.**
LANE Config Server: 47.0091810000000061705b7701.00400BFF0013.00
ATM#
```

Note The two asterisks (**) represent the subinterface number byte in hexadecimal.

- Step 4** Using the LECS address obtained in Step 3, set the address of the default LECS in the LightStream 1010 switch by entering the **configure terminal** and **atm lecs-address atm_address** commands on the console of the LightStream 1010 switch. You see this display:

```
Switch> enable
Switch#
Switch#configure terminal
Enter configuration commands, one per line. End with CNTL/Z.
Switch(config)#atm lecs-address 47.0091810000000061705b7701.00400BFF0013.00 1
Switch(config)#end
Switch#
```

The commands shown in this step configure the LECS address in the switch. The LECS ATM NSAP address is 47.0091810000000061705b7701.00400BFF0013.00. The sequence number of this LECS address, which is 1, means it is the first LECS in this switch.

- Step 5** Save the configuration as follows:

```
ATM#write memory
```

- Step 6** Start up a LES/BUS pair on Catalyst 5000 series Switch 1 by entering the **interface atm0** and the **lane server-bus ethernet default** commands in configuration mode. On the console of Catalyst 5000 series Switch 1, enter these commands:

```
ATM#config terminal
Enter configuration commands, one per line. End with CNTL/Z.
ATM(config)#interface atm0
ATM(config-subif)#lane server-bus ethernet default
ATM(config-subif)#end
ATM#
```

The commands shown in this step start a LES/BUS pair. The ELAN name is default, and the interface on which this LES/BUS pair is configured is atm0.

- Step 7** Save the configuration as follows:

```
ATM#write memory
```

- Step 8** Set up the LECS database on the Catalyst 5000 series Switch 1.

Enter the LANE server address obtained in Step 3 and replace the ** with the subinterface number of the interface in which the LES/BUS is to be configured. In this example, that number is 00. Enter the **lane database database_name** command, the **name elan_name server-atm-address atm_address** command, and the **default-name elan_name** commands at the ATM prompt. You see this display:

```
ATM#config terminal
Enter configuration commands, one per line. End with CNTL/Z.
ATM(config)#lane database test
ATM(lane-config-database)#name default server-atm-address 47.0091810000000061705b7701.00400BFF0011.00
ATM(lane-config-database)#default-name default
ATM(lane-config-database)#end
ATM#
```

The commands shown in this step create the LECS database. The database name is test. The ELAN name is default. The LES ATM NSAP address is 47.0091810000000061705b7701.00400BFF0011.00.

- Step 9** Save the configuration as follows:

```
ATM#write memory
```

- Step 10** Start and bind the LECS on the Catalyst 5000 series Switch 1 by entering the **interface atm0** command, the **lane config database database_name** command, and the **lane config auto-config-atm-address** command at the ATM prompt. You see this display:

```
ATM#config terminal
Enter configuration commands, one per line. End with CNTL/Z.
ATM(config)#interface atm0
ATM(config-if)#lane config database test
ATM(config-if)#lane config auto-config-atm-address
ATM(config-if)#end
ATM#
```

The commands shown in this step start the LECS. The database name to use is test. The interface on which the LECS is configured is atm0.

- Step 11** Save the configuration as follows:

```
ATM#write memory
```

- Step 12** Start the LEC on the Catalyst 5000 series Switches 1 and 2 by entering the **interface atm0.1** command and the **lane client ethernet 1 default** command in configuration mode on the consoles of Switches 1 and 2. The interface on which the LEC is configured is atm0.1. The ELAN name is default, and it is configured to emulate Ethernet. You see this display:

```
ATM#configure terminal
Enter configuration commands, one per line. End with CNTL/Z.
ATM(config)#interface atm0.1
ATM(config-subif)#lane client ethernet 1 default
ATM(config-subif)#end
ATM#
```

- Step 13** Save the configuration as follows:

```
ATM#write memory
```

- Step 14** Create a LES/BUS pair on Catalyst 5000 series Switch 1 for VLAN 2 by entering the **interface atm0.2** command and the **lane server-bus ethernet VLAN0002** command in configuration mode. You see this display:

```
ATM#config terminal
Enter configuration commands, one per line. End with CNTL/Z.
ATM(config-subif)#interface atm0.2
ATM(config-subif)#lane server-bus ethernet VLAN0002
ATM(config-subif)#end
ATM#
```

- Step 15** Save the configuration as follows:

```
ATM#write memory
```

- Step 16** Configure the address of the new LES/BUS pair in the LECS database on Catalyst 5000 series Switch 1 by entering the **lane database test** command and the **name VLAN0002 server-atm-address atm_address** command in configuration mode. You see this display:

```
ATM#configure terminal
ATM(config)#lane database test
ATM(lane-config-database)#name VLAN0002 server-atm-address 47.009181000000061705b7701.00400BFF0011.02
ATM(lane-config-database)#end
ATM#
```

Step 17 Save the configuration as follows:

```
ATM#write memory
```

Step 18 Start the new LEC on Catalyst 5000 series Switch 2 by entering the **interface atm0.2** command and the **lane client ethernet 2 VLAN0002** command in configuration mode. You see this display:

```
ATM#configure terminal
Enter configuration commands, one per line. End with CNTL/Z.
ATM(config)#interface atm0.2
ATM(config-subif)#lane client ethernet 2 VLAN0002
ATM(config-subif)#end
ATM#
```

Step 19 Save the configuration as follows:

```
ATM#write memory
```

Example Configuration 2

Figure 35-4 shows three Catalyst 5000 series switches (Catalyst 5000 series Switch 1, Switch 2, and Switch 3) and a LightStream 1010 ATM switch. LES/BUS/LECS redundancy is configured. Switches 1 and 2 both have one LES/BUS/LECS for every ELAN. Switch 1 is the master server, and Switch 2 is the backup server. If Switch 1 fails, Switch 2 provides the LES/BUS/LECS components of the ELAN. Once Switch 1 recovers, it becomes the master server again.

Figure 35-4 LES/BUS/LECS Redundancy

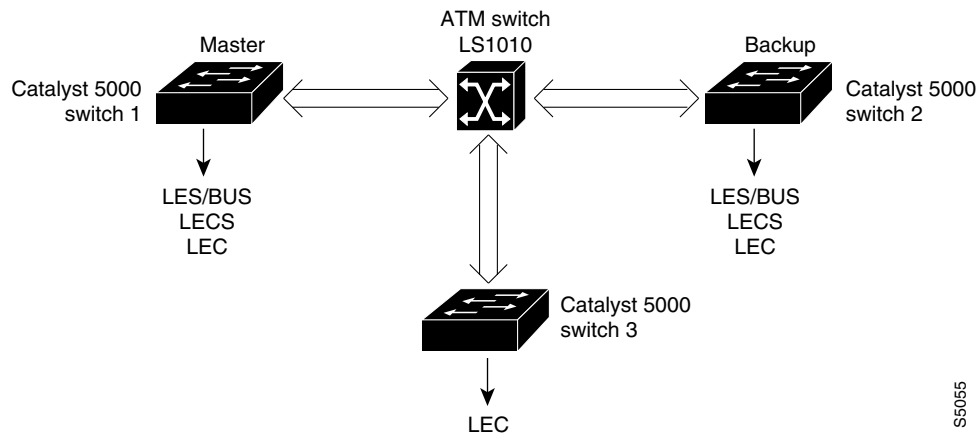

Example Configuration 2 Assumptions

In Figure 35-4, these assumptions apply:

- The Catalyst 5000 series Switch 1 is the master. It runs the LES/BUS and LECS on interface atm0 and runs the LEC on interface atm0.1.
- The Catalyst 5000 series Switch 2 is the backup server. It runs LES/BUS and LECS on interface atm0 and runs the LEC on interface atm0.1.
- The Catalyst 5000 series Switch 3 runs the LEC on interface atm0.1.
- The ATM module is installed in slot 4 of each Catalyst 5000 series switch.

Example Configuration 2 Procedure

To set up the configuration in Figure 35-4, perform these steps:

- Step 1** Set up the prefix of the ATM NSAP address for the switch.

The LightStream 1010 ATM switch provides a default prefix.

- Step 2** Establish a connection with the ATM module from Switch 1 by entering the **session** command. You see this display:

```
Console> session 4
Trying ATM-4...
Connected to ATM-4.
Escape character is '^]'.
```

- Step 3** Obtain the LES and LES/BUS addresses for later use by entering the **show lane default** command. You see this display:

```
ATM>show lane default
interface ATM0:
LANE Client:      47.0091810000000061705b7701.00400BFF0010.**
LANE Server:     47.0091810000000061705b7701.00400BFF0011.**
LANE Bus:        47.0091810000000061705b7701.00400BFF0012.**
LANE Config Server: 47.0091810000000061705b7701.00400BFF0013.00
ATM>
```

Note The two asterisks (**) represent the subinterface number byte displayed in hexadecimal.

- Step 4** Establish a connection to the ATM module from Switch 2 by entering the **session** command. You see this display:

```
Console> session 4
Trying ATM-4...
Connected to ATM-4.
Escape character is '^]'.
```

- Step 5** Obtain the LES and LES/BUS addresses for later use by entering the **show lane default** command from privileged mode. You see this display:

```
ATM>
ATM>enable
ATM#
ATM#show lane default
interface ATM0:
LANE Client:      47.0091810000000061705b7701.00400B583040.**
LANE Server:     47.0091810000000061705b7701.00400B583041.**
LANE Bus:        47.0091810000000061705b7701.00400B583042.**
LANE Config Server: 47.0091810000000061705b7701.00400B583043.00
ATM#
```

Note The two asterisks (**) represent the subinterface number byte displayed in hexadecimal.

- Step 6** Set up the LECS database on Switches 1 and 2. Enter the LES addresses obtained in Steps 3 and 5 and replace the two asterisks (**) with the subinterface numbers of the interfaces in which the LES/BUS is to be configured. In this example, that number is 00.

Enter the **lane database** *database-name* command, the **name** *elan_name* **server-atm-address** *atm_address* command, and the **default-name** *elan_name* commands in configuration mode on both Switch 1 and Switch 2.

Note The order of the entries is critical and should be the same on both the primary and secondary Catalyst 5000 series switches for this configuration to work effectively.

After entering these commands, you see this display:

```
ATM#configure terminal
Enter configuration commands, one per line. End with CNTL/Z.
ATM(config)#lane database test
ATM(lane-config-database)#name default server-atm-address
47.0091810000000061705b7701.00400BFF0011.00
ATM(lane-config-database)#name default server-atm-address
47.0091810000000061705b7701.00400B583041.00
ATM(lane-config-database)#default-name default
ATM(lane-config-database)#end
ATM#
```

In this example, the name of the database is test. The name of the ELAN is default. The first entry is the primary LES. The second entry is the backup LES. The primary LES ATM NSAP address is 47.0091810000000061705b7701.00400BFF0011.00. The backup LES ATM NSAP address is 47.0091810000000061705b7701.00400B583041.00.

Step 7 Save the configuration as follows:

```
ATM#write memory
```

Step 8 Start and bind the LECS on both the Catalyst 5000 series Switches 1 and 2 by entering the **interface atm0** command, the **lane config database** *database_name* command, and the **lane config auto-config-atm-address** command in configuration mode on both Switch 1 and Switch 2. You see this display:

```
ATM#configure terminal
Enter configuration commands, one per line. End with CNTL/Z.
ATM(config)#interface atm0
ATM(config-if)#lane config test
ATM(config-if)#lane config auto-config-atm-address
ATM(config-if)#end
ATM#
```

In this example, the database name is test and the interface on which the LECS is configured is atm0.

Step 9 Save the configuration as follows:

```
ATM#write memory
```

Step 10 Start up a LES/BUS pair on Switch 1 and Switch 2 by entering the **interface atm0** command and the **lane server-bus ethernet default** command on the consoles of Switch 1 and Switch 2. You see this display:

```
ATM#configure terminal
Enter configuration commands, one per line. End with CNTL/Z.
ATM(config)#interface atm0
ATM(config-subif)#lane server-bus ethernet default
ATM(config-subif)#end
ATM#
```

In this example, the ELAN name is default and the interface on which this LES/BUS pair is configured is atm0.

- Step 11** Save the configuration as follows:

```
ATM#write memory
```

- Step 12** Set the LECS addresses on Switches 1 and 2 in the ATM switch by entering the **atm lecs-address atm_address** command in configuration mode on the console of the LightStream 1010 switch for each Catalyst 5000 series switch. These commands configure the address of the primary and the backup LECSs in the ATM switch, in the order presented on the screen. Enter the LANE configuration server address obtained in Steps 3 and 5. You see this display:

```
ATM>enable
ATM#config terminal
Enter configuration commands, one per line. End with CNTL/Z.
ATM(config)#atm lecs-address 47.0091810000000061705b7701.00400BFF0013.00 1
ATM(config)#atm lecs-address 47.0091810000000061705b7701.00400B583043.00 2
ATM(config)#end
ATM#
```

- Step 13** Save the configuration as follows:

```
ATM#write memory
```

- Step 14** Start the LEC on Switches 1, 2, and 3 by entering the **interface atm0.1** command and the **lane client ethernet 1 default** command in configuration mode on the consoles of Switches 1, 2, and 3. You see this display:

```
ATM#configure terminal
Enter configuration commands, one per line. End with CNTL/Z.
ATM(config)#interface atm0.1
ATM(config-subif)#lane client ethernet 1 default
ATM(config-subif)#end
ATM#
```

The interface on which the LEC is configured is atm0.1. The ELAN name is default, and it is configured to emulate Ethernet.

- Step 15** Save the configuration as follows:

```
ATM#write memory
```

Note To use VTP to create the LEC, see the “Creating LECs Automatically Using VTP” section on page 35-24.

- Step 16** Create a LES/BUS pair on Switches 1 and 2 for VLAN 2. Enter the **interface atm0.2** command and the **lane server-bus ethernet VLAN 0002** command in configuration mode on the consoles of Switches 1 and 2. You see this display:

```
ATM#configure terminal
Enter configuration commands, one per line. End with CNTL/Z.
ATM(config-subif)#interface atm0.2
ATM(config-subif)#lane server-bus ethernet VLAN0002
ATM(config-subif)#end
ATM#
```

- Step 17** Save the configuration as follows:

```
ATM#write memory
```

Step 18 Configure the address of the new LES/BUS pair in the LECS database on Switch 1:

```
ATM#configure terminal
ATM(config)#lane database test
ATM(lane-config-database)#name VLAN0002 server-atm-address
47.0091810000000061705b7701.00400BFF0011.02
ATM(lane-config-database)#name VLAN0002 server-atm-address
47.0091810000000061705b7701.00400B583041.02
ATM(lane-config-database)#end
ATM#
```

Step 19 Save the configuration as follows:

```
ATM#write memory
```

Step 20 Start the new LEC on Switch 3 by entering the **interface atm0.2** command and the **lane client ethernet 2 VLAN0002** command on the console of Switch 3.

```
ATM#configure terminal
Enter configuration commands, one per line. End with CNTL/Z.
ATM(config)#interface atm0.2
ATM(config-subif)#lane client ethernet 2 VLAN0002
ATM(config-subif)#end
ATM#
```

Step 21 Save the configuration as follows:

```
ATM#write memory
```

Example Configuration 3

Figure 35-5 shows two ATM switches in an ATM cloud. ATM Switch 1 is connected to two Catalyst 5000 series switches (Catalyst 5000 series Switch 1 and Catalyst 5000 series Switch 2), which have ATM dual PHY modules. ATM Switch 2 is also connected to Catalyst 5000 series Switch 1 and Catalyst 5000 series Switch 2. If PHY A on Catalyst 5000 series Switch 1 is lost, data continues to flow to Catalyst 5000 series Switch 2 on PHY B, showing dual PHY redundancy.

Figure 35-5 LES/BUS/LECS Redundancy with Dual PHYs

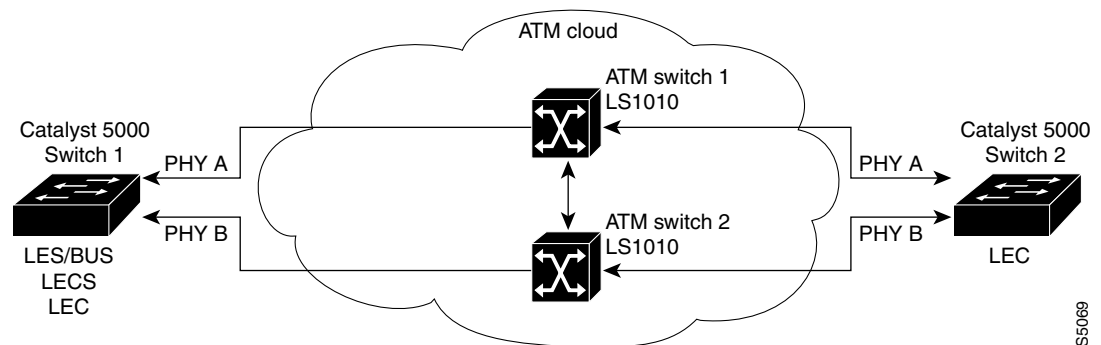

Example Configuration 3 Assumptions

In Figure 35-5, these assumptions apply:

- The LightStream 1010 switch is used.
- Catalyst 5000 series switches with the ATM modules installed are running ATM software release 3.1 or later.
- Catalyst 5000 series Switch 1 runs the LECS on interface atm0.
- Catalyst 5000 series Switch 1 runs the LES/BUS and LEC for VLAN/ELAN1 on interface atm0.1.
- Catalyst 5000 series Switch 1 runs the LES/BUS and LEC for VLAN/ELAN 2 on subinterface atm0.2.
- Catalyst 5000 series Switch 2 runs the LEC for ELAN/VLAN 1 on interface atm0.1.
- Catalyst 5000 series Switch 2 runs the LEC for ELAN/VLAN 2 on interface atm0.2.
- The ATM module is installed in slot 4 of the Catalyst 5000 series switches.
- You can change the ELAN name by entering the **set vlan** *vlan_num* [*name*] command.

Example Configuration 3 Procedure

To set up LANE on the configuration in Figure 35-5, perform these steps:

Step 1 Set up the prefix of the ATM NSAP address for the switch.

The LightStream 1010 ATM switch provides a default prefix.

Step 2 Establish a connection to the ATM module by entering the **session** command at the Catalyst 5000 series switch console prompt. You see this display:

```
Console> session 4
Trying ATM-4...
Connected to ATM-4.
Escape character is '^]'.
```

Step 3 Obtain the LECS and LES/BUS addresses for later use by entering the **show lane default** command in privileged mode at the ATM prompt. You see this display:

```
ATM>enable
ATM#
ATM#show lane default
interface ATM0:
LANE Client:      47.0091810000000061705b7701.00400BFF0010.**
LANE Server:     47.0091810000000061705b7701.00400BFF0011.**
LANE Bus:        47.0091810000000061705b7701.00400BFF0012.**
LANE Config Server: 47.0091810000000061705b7701.00400BFF0013.00
ATM#
```

Note The two asterisks (**) represent the subinterface number byte displayed in hexadecimal.

- Step 4** Access path B by entering the **interface atm0** and the **atm preferred phy B** commands in configuration mode. You see this display:

```
ATM#configure terminal
Enter configuration commands, one per line. End with CNTL/Z.
ATM(config)#interface atm0
ATM(config-subif)#atm preferred phy B
ATM(config-subif)#end
ATM#
```

Wait for approximately one minute while the PHY B comes up.

- Step 5** Enter the **show lane default** command. The two asterisks (**) represent the subinterface number byte displayed in hexadecimal. You see this display:

```
ATM#show lane default
interface ATM0:
LANE Client:      47.0091810000000061705b8301.00400BFF0010.**
LANE Server:     47.0091810000000061705b8301.00400BFF0011.**
LANE Bus:        47.0091810000000061705b8301.00400BFF0012.**
LANE Config Server: 47.0091810000000061705b8301.00400BFF0013.00
ATM#
```

- Step 6** Return to PHY A by entering the **interface atm0** and the **atm preferred phy A** commands in configuration mode. You see this display:

```
ATM#configure terminal
Enter configuration commands, one per line. End with CNTL/Z.
ATM(config)#interface atm0
ATM(config-subif)#atm preferred phy A
ATM(config-subif)#end
ATM#
```

- Step 7** Set the address of the default LECS in the ATM switches by entering the addresses from Steps 3 and 4. Enter the **atm lecs-address atm_address** command on the console of the LightStream 1010 Switch 1. These commands configure the address of the primary and the backup LECSs in the ATM switches in the specific order entered. Only one LECS runs on the Catalyst 5000 series Switch 1, but the address (the first 13 bytes) changes if PHY B is used instead of PHY A. After entering the commands, you see this display:

```
ATM>enable
ATM#configure terminal
Enter configuration commands, one per line. End with CNTL/Z.
ATM(config)#atm lecs-address 47.0091810000000061705b7701.00400BFF0013.00 1
ATM(config)#atm lecs-address 47.0091810000000061705b8301.00400BFF0013.00 2
ATM(config)#end
ATM#
```

- Step 8** Save the configuration as follows:

```
ATM#write memory
```

- Step 9** Enter the **interface atm0** and **lane server-bus ethernet default** commands in configuration mode on the console of Catalyst 5000 series Switch 1. These commands start a LES/BUS pair. The ELAN name is default. The interface on which this LES/BUS pair is configured is atm0. You see this display:

```
ATM#configure terminal
Enter configuration commands, one per line. End with CNTL/Z.
ATM(config)#interface atm0
ATM(config-subif)#lane server-bus ethernet default
ATM(config-subif)#end
ATM#
```

Step 10 Save the configuration as follows:

```
ATM#write memory
```

Step 11 Configure the LECS database of the Catalyst 5000 series Switch 1 by entering the **lane database** *database_name* command, the **name** *elan_name* **server-atm-address** *atm address* command, and the **default-name** *elan_name* command. You see this display:

```
ATM#configure terminal
Enter configuration commands, one per line. End with CNTL/Z.
ATM(config)#lane database test
ATM(lane-config-database)#name default server-atm-address 47.009181000000061705b7701.00400BFF0011.00
ATM(lane-config-database)#name default server-atm-address 47.0091810000000061705b8301.00400BFF0011.00
ATM(lane-config-database)#default-name default
ATM(lane-config-database)#end
ATM#
```

Enter the LANE server addresses from Steps 3 and 4. Replace the two asterisks (**) with the subinterface number of the interface in which the LES/BUS is to be configured. In this example, the number is 00. These commands create the LECS database. The name of the database is test. The name of the ELAN is default.

The ATM NSAP address of the LES is 47.009181000000061705b7701.00400BFF0011.00. The display in Step 3 shows this LANE BUS address.

The ATM NSAP address of the LES is 47.009181000000061705b8301.00400BFF0011.00. The display in Step 4 shows this LANE BUS address.

Step 12 Save the configuration as follows:

```
ATM#write memory
```

Step 13 Start and bind the LECS on the Catalyst 5000 series Switch 1 by entering the **interface atm0** command, the **lane config database** *database_name* command, and the **lane config auto-config-atm-address** command in configuration mode at the ATM prompt. The database name is test. The interface on which the LECS is configured is atm0. After entering these commands, you see this display:

```
ATM#configure terminal
Enter configuration commands, one per line. End with CNTL/Z.
ATM(config)#interface atm0
ATM(config-if)#lane config test
ATM(config-if)#lane config auto-config-atm-address
ATM(config-if)#end
ATM#
```

Step 14 Save the configuration as follows:

```
ATM#write memory
```

- Step 15** Start a LEC on the Catalyst 5000 series Switches 1 and 2 by entering the **interface atm0.1** and **lane client ethernet 1 default** commands in configuration mode on the consoles of each Catalyst 5000 series switch. The interface on which the LEC is configured is atm0.1. The ELAN name is default, and it is configured to emulate Ethernet. After entering the commands, you see this display:

```
ATM#configure terminal
Enter configuration commands, one per line. End with CNTL/Z.
ATM(config)#interface atm0.1
ATM(config-subif)#lane client ethernet 1 default
ATM(config-subif)#end
ATM#
```

- Step 16** Save the configuration as follows:

```
ATM#write memory
```

- Step 17** Create a LES/BUS pair on the Catalyst series Switch 1 for VLAN 2 by entering the **interface atm0.2** and **lane server-bus ethernet VLAN0002** commands in configuration mode. You see this display:

```
ATM#configure terminal
Enter configuration commands, one per line. End with CNTL/Z.
ATM(config)#interface atm0.2
ATM(config-subif)#lane server-bus ethernet VLAN0002
ATM(config-subif)#end
ATM#
```

- Step 18** Save the configuration as follows:

```
ATM#write memory
```

- Step 19** Configure the address of the new LES/BUS pair in the LECS database on the Catalyst 5000 series Switch 1 by entering the **lane database database_name** and **name elan_name server-atm-address atm_address** commands in configuration mode. You see this display:

```
ATM#configure terminal
ATM(config)#lane database test
ATM(lane-config-database)#name VLAN0002 server-atm-address 47.009181000000061705b7701.00400BFF0011.02
ATM(lane-config-database)#name VLAN0002 server-atm-address 47.009181000000061705b8301.00400BFF0011.02
ATM(lane-config-database)#end
ATM#
```

- Step 20** Save the configuration as follows:

```
ATM#write memory
```

- Step 21** Start the new LEC on the Catalyst 5000 series Switch 2 by entering the **interface atm0.2** and **lane client ethernet 2 VLAN0002** commands in configuration mode on the console of Catalyst 5000 series Switch 2. You see this display:

```
ATM#configure terminal
Enter configuration commands, one per line. End with CNTL/Z.
ATM(config)#interface atm0.2
ATM(config-subif)#lane client ethernet 2 VLAN0002
ATM(config-subif)#end
ATM#
```

- Step 22** Save the configuration as follows:

```
ATM#write memory
```