

## Configuring Port Security

This chapter describes how to configure port security on the Catalyst 4500 series switch. It provides an overview of port security on the Catalyst 4500 series switch and details the configuration on various types of ports such as access, voice, trunk and private VLAN.

This chapter consists of these sections:

- [Command List, page 38-1](#)
- [Overview of Port Security, page 38-3](#)
- [Port Security on Access Ports, page 38-6](#)
- [Port Security on a Private VLAN Port, page 38-13](#)
- [Port Security on Trunk Ports, page 38-16](#)
- [Port Security on Voice Ports, page 38-21](#)
- [Displaying Port Security Settings, page 38-27](#)
- [Configuring Port Security with Other Features/Environments, page 38-30](#)
- [Port Security Guidelines and Restrictions, page 38-32](#)

For information on how to troubleshoot Port Security, refer to the “[Troubleshooting Port Security](#)” section on page 51-35.



### Note

For complete syntax and usage information for the switch commands used in this chapter, refer to the *Catalyst 4500 Series Switch Cisco IOS Command Reference* and related publications at this location:

<http://www.cisco.com/univercd/cc/td/doc/product/software/ios122sr/cr/index.htm>

## Command List

This table lists the commands most commonly used with Port Security.

Command	Purpose	Navigation
<code>errdisable recovery cause psecure-violation</code>	Brings a secure port out of error-disabled state	<a href="#">Violation Actions, page 38-6</a>
<code>errdisable recovery interval</code>	Customizes the time to recover from a specified error disable cause	<a href="#">Violation Actions, page 38-6</a>

Command	Purpose	Navigation
<b>port-security mac-address</b>	Configures all secure MAC addresses on each VLAN	<a href="#">Secure MAC Addresses, page 38-3</a>
<b>port-security maximum</b>	Configures a maximum number of MAC addresses on an interface	<a href="#">Configuring Port Security on Access Ports, page 38-7</a>
<b>private-vlan association add</b>	Creates an association between a secondary VLAN and a primary VLAN	<a href="#">Example of Port Security on an Isolated Private VLAN Host Port, page 38-15</a>
<b>private-vlan isolated</b>	Designates the VLAN as a private VLAN	<a href="#">Configuring Port Security on an Isolated Private VLAN Host Port, page 38-14</a>
<b>private-vlan primary</b>	Specifies the VLAN as the primary private VLAN	<a href="#">Configuring Port Security on an Isolated Private VLAN Host Port, page 38-14</a>
<b>switchport mode private-vlan host</b>	Specifies that ports with valid private VLAN trunk association become active host private VLAN trunk ports	<a href="#">Configuring Port Security on an Isolated Private VLAN Host Port, page 38-14</a>
<b>switchport private-vlan host-association</b>	Defines a host association on an isolated host port	<a href="#">Configuring Port Security on an Isolated Private VLAN Host Port, page 38-14</a>
<b>switchport private-vlan mapping</b>	Defines a private VLAN for the promiscuous ports	<a href="#">Configuring Port Security on an Isolated Private VLAN Host Port, page 38-14</a>
<b>switchport port-security</b>	Enables port security	<a href="#">Configuring Port Security on Access Ports, page 38-7</a>
<b>switchport port-security aging static</b>	Configures static aging of MAC address.	<a href="#">Aging Secure MAC Addresses, page 38-5</a>
<b>switchport port-security aging time</b>	Specifies an aging time for a port	<a href="#">Example 3: Setting the Aging Timer, page 38-11</a>
<b>switchport port-security limit rate invalid-source-mac</b>	Sets the rate limit for bad packets	<a href="#">Example 7: Setting a Rate Limit for Bad Packets, page 38-13</a>
<b>switchport port-security mac-address</b>	Configures a secure MAC address for an interface	<a href="#">Example 5: Configuring a Secure MAC Address, page 38-11</a>
<b>switchport port-security mac-address &lt;mac_address&gt; sticky</b>	Specifies the sticky MAC address for an interface	<a href="#">Configuring Port Security on Access Ports, page 38-7</a>
<b>switchport port-security mac-address sticky</b>	Enables sticky Port Security	<a href="#">Sticky Addresses on a Port, page 38-5</a>
<b>no switchport port-security mac-address sticky</b>	Converts a sticky secure MAC address to a dynamic MAC secure address	<a href="#">Configuring Port Security on Access Ports, page 38-7</a>
<b>switchport port-security maximum</b>	Sets the maximum number of secure MAC addresses for an interface	<a href="#">Example 1: Setting Maximum Number of Secure Addresses, page 38-10</a>
<b>switchport port-security violation</b>	Sets the violation mode	<a href="#">Example 2: Setting a Violation Mode, page 38-10</a>

Command	Purpose	Navigation
<code>no switchport port-security violation</code>	Sets the violation mode	<a href="#">Configuring Port Security on Access Ports, page 38-7</a>
<code>switchport trunk encapsulation dot1q</code>	Sets the encapsulation mode to dot1q	<a href="#">Example 1: Configuring a Maximum Limit of Secure MAC Addresses for all VLANs, page 38-18</a>

## Overview of Port Security

Port security enables you to restrict the number of MAC addresses (termed *secure MAC addresses*) on a port, allowing you to prevent access by unauthorized MAC addresses. It also allows you to configure a maximum number of secure MAC addresses on a given port (and optionally for a VLAN for trunk ports). When a secure port exceeds the maximum, a security violation is triggered, and a violation action is performed based on the violation action mode configured on the port.

If you configure the maximum number of secure MAC addresses as 1 on the port, the device attached to the secure port is assured sole access to the port.

If a secure MAC address is secured on a port, that MAC address is not allowed to enter on any other port off that VLAN. If it does, the packet is dropped unnoticed in the hardware. Other than through the interface or port counters, you do not receive a log message reflecting this fact. Be aware that this condition does not trigger a violation. Dropping these packets in the hardware is more efficient and can be done without putting additional load on the CPU.

Port Security has the following characteristics:

- It allows you to age out secure MAC addresses. Two types of aging are supported: inactivity and absolute.
- It supports a sticky feature whereby the secure MAC addresses on a port are retained through switch reboots and link flaps.
- It can be configured on various types of ports such as access, voice, trunk, EtherChannel, and private VLAN ports.

This overview contains the following topics:

- [Secure MAC Addresses, page 38-3](#)
- [Maximum Number of Secure MAC Addresses, page 38-4](#)
- [Aging Secure MAC Addresses, page 38-5](#)
- [Sticky Addresses on a Port, page 38-5](#)
- [Violation Actions, page 38-6](#)

## Secure MAC Addresses

Port Security supports the following types of secure MAC addresses:

- **Dynamic or Learned**—Dynamic secure MAC addresses are learned when packets are received from the host on the secure port. You might want to use this type if the user's MAC address is not fixed (laptop).
- **Static or Configured**—Static secure MAC addresses are configured by the user through CLI or SNMP. You might want to use this type if your MAC address remains fixed (PC).

- Sticky—Sticky addresses are learned like dynamic secure MAC addresses, but persist through switch reboots and link flaps like static secure MAC addresses. You might want to use this type if a large number of fixed MAC addresses exist and you do not want to configure MAC addresses manually (100 PCs secured on their own ports).

If a port has reached its maximum number of secure MAC addresses and you try to configure a static secure MAC address, your configuration is rejected and an error message displays. If a port has reached its maximum number of secure MAC addresses and a new dynamic secure MAC address is added, a violation action is triggered.

You can clear dynamic secure MAC addresses with the **clear port-security** command. You can clear sticky and static secure MAC addresses one at a time with the **no** form of the **switchport port-security mac-address** command.

## Maximum Number of Secure MAC Addresses

A secure port has a default of one MAC address. You can change the default to any value between 1 and 3,000. The upper limit of 3,000 guarantees one MAC address per port and an additional 3,000 across all ports in the system.

After you have set the maximum number of secure MAC addresses on a port, you can include the secure addresses in an address table in one of the following ways:

- You can configure the secure MAC addresses with the **switchport port-security mac-address mac\_address** interface configuration command.
- You can configure all secure MAC addresses on a range of VLANs with the **port-security mac-address VLAN range** configuration command for trunk ports.
- You can allow the port to dynamically configure secure MAC addresses with the MAC addresses of connected devices.
- You can configure some of the addresses and allow the rest to be dynamically configured.



### Note

If a port's link goes down, all dynamically secured addresses on that port are no longer secure.

- You can configure MAC addresses to be sticky. These can be dynamically learned or manually configured, stored in the address table, and added to the running configuration. After these addresses are saved in the configuration file, the interface does not need to dynamically relearn them when the switch restarts. Although you can manually configure sticky secure addresses, this action is not recommended.



### Note

On a trunk port, a maximum number of secure MAC addresses can be configured on both the port and port VLAN. The port's maximum value can be greater than or equal to the port VLAN maximum(s) but not less than the port VLAN maximum(s). If the port's maximum value is less than at least one of the port VLAN's maximum (i.e. if we have max set to 3 on VLAN 10 while no "sw port max" is set (defaults to 1)), the port shuts down when dynamic adds reaches 2 on VLAN 10 (see "Port Security Guidelines and Restrictions" on page 32). The port VLAN maximum enforces the maximum allowed on a given port on a given VLAN. If the maximum is exceeded on a given VLAN but the port's maximum is not exceeded, the port still shuts down. The entire port is shut down even if one of the VLANs on the port has actually caused the violation.

## Aging Secure MAC Addresses

You might want to age secure MAC addresses when the switch may be receiving more than 3,000 MAC addresses ingress.

**Note**

---

Aging of sticky addresses is not supported.

---

By default, port security does not age out the secure MAC addresses. After learned, the MAC addresses remain on the port until either the switch reboots or the link goes down (unless the sticky feature is enabled). However, port security does allow you to configure aging based on the absolute or inactivity mode and aging interval (in minutes, from 1 to n).

- Absolute mode: ages between n and n+1
- Inactivity mode: ages between n+1 and n+2

Use this feature to remove and add PCs on a secure port without manually deleting the existing secure MAC addresses, while still limiting the number of secure addresses on a port.

Unless static aging is explicitly configured with the **switchport port-security aging static** command, static addresses are not aged even if aging is configured on the port.

**Note**

---

The aging increment is one minute.

---

## Sticky Addresses on a Port

By enabling *sticky* port security, you can configure an interface to convert the dynamic MAC addresses to sticky secure MAC addresses and to add them to the running configuration. You might want to do this if you do not expect the user to move to another port, and you want to avoid statically configuring a MAC address on every port.

**Note**

---

If you use a different chassis, you might need another MAC address.

---

To enable sticky port security, enter the **switchport port-security mac-address sticky** command. When you enter this command, the interface converts all the dynamic secure MAC addresses, including those that were dynamically learned before sticky learning was enabled, to sticky secure MAC addresses.

The sticky secure MAC addresses do not automatically become part of the configuration file, which is the startup configuration used each time the switch restarts. If you save the running config file to the configuration file, the interface does not need to relearn these addresses when the switch restarts. If you do not save the configuration, they are lost.

If sticky port security is disabled, the sticky secure MAC addresses are converted to dynamic secure addresses and are removed from the running configuration.

After the maximum number of secure MAC addresses is configured, they are stored in an address table. To ensure that an attached device has sole access of the port, configure the MAC address of the attached device and set the maximum number of addresses to one, which is the default.

A security violation occurs if the maximum number of secure MAC addresses to a port has been added to the address table and a workstation whose MAC address is not in the address table attempts to access the interface.

## Violation Actions

A security violation is triggered when the number of secure MAC addresses on the port exceeds the maximum number of secure MAC addresses allowed on the port.



### Note

A secure violation is not triggered if the host secured on one port shows up on another port. The Catalyst 4500 series switch drops such packets on the new port silently in the hardware and does not overload the CPU.

You can configure the interface for one of following violation modes, which are based on the response to the violation:

- **Restrict**—A port security violation restricts data (that is, packets are dropped in software), causes the SecurityViolation counter to increment, and causes an SNMP Notification to be generated. You might want to configure this mode in order to provide uninterrupted service/access on a secure port.

The rate at which SNMP traps are generated can be controlled by the **snmp-server enable traps port-security trap-rate** command. The default value (“0”) causes an SNMP trap to be generated for every security violation.

- **Shutdown**—A port security violation causes the interface to shut down immediately. You might want to configure this mode in a highly secure environment, where you do not want unsecured MAC addresses to be denied in software and service interruption is not an issue.

When a secure port is in the error-disabled state, you can bring it out of this state automatically by configuring the **errdisable recovery cause psecure-violation** global configuration command or you can manually reenable it by entering the **shutdown** and **no shut down** interface configuration commands. This is the default mode.

You can also customize the time to recover from the specified error disable cause (default is 300 seconds) by entering the **errdisable recovery interval interval** command.

## Invalid Packet Handling

You might want to rate limit invalid source MAC address packets on a secure port if you anticipate that a device will send invalid packets (such as traffic generator, sniffer, and bad NICs). Port security considers packets with all zero MAC addresses, as well as multicast or broadcast source MAC address, as invalid packets. You can chose to rate limit these packets, and if the rate is exceeded, trigger a violation action for the port.

## Port Security on Access Ports

These sections describe how to configure port security:

- [Configuring Port Security on Access Ports, page 38-7](#)
- [Examples, page 38-10](#)



### Note

Port security can be enabled on a Layer 2 port channel interface configured in access mode. The port security configuration on an EtherChannel is kept independent of the configuration of any physical member ports.

## Configuring Port Security on Access Ports

To restrict traffic through a port by limiting and identifying MAC addresses of the stations allowed to the port, perform this task:

	Command	Purpose
Step 1	Switch(config)# <b>interface</b> <i>interface_id</i> <b>interface</b> <i>port-channel port_channel_number</i>	Enters interface configuration mode and specifies the interface to configure.  <b>Note</b> The interface can be a Layer 2 port channel logical interface.
Step 2	Switch(config-if)# <b>switchport mode access</b>	Sets the interface mode.  <b>Note</b> An interface in the default mode (dynamic desirable) cannot be configured as a secure port.
Step 3	Switch(config-if)# [ <b>no</b> ] <b>switchport port-security</b>	Enables port security on the interface.  To return the interface to the default condition as nonsecure port, use the <b>no switchport port-security</b> command.
Step 4	Switch(config-if)# [ <b>no</b> ] <b>switchport port-security maximum value</b>	(Optional) Sets the maximum number of secure MAC addresses for the interface. The range is 1 to 3072; the default is 1.  To return the interface to the default number of secure MAC addresses, use the <b>no switchport port-security maximum value</b> .

Command	Purpose (continued)
<b>Step 5</b> Switch(config-if)# <b>switchport port-security</b> [aging {static   time aging_time   type {absolute   inactivity}}]	Sets the aging time and aging type for all secure addresses on a port.  Use this feature to remove and add PCs on a secure port without manually deleting the existing secure MAC addresses while still limiting the number of secure addresses on a port.  The <b>static</b> keyword enables aging for statically configured secure addresses on this port.  The <b>time aging_time</b> keyword specifies the aging time for this port. Valid range for <i>aging_time</i> is from 0 to 1440 minutes. If the time is equal to 0, aging is disabled for this port.  The <b>type</b> keyword sets the aging type as <b>absolute</b> or <b>inactive</b> . <ul style="list-style-type: none"> <li>• <b>absolute</b>—All the secure addresses on this port age out exactly after the time (minutes) specified and are removed from the secure address list.</li> <li>• <b>inactive</b>—The secure addresses on this port age out only if there is no data traffic from the secure source address for the specified time period.</li> </ul> To disable port security aging for all secure addresses on a port, use the <b>no switchport port-security aging time</b> interface configuration command.
<b>Step 6</b> Switch(config-if)# [no] <b>switchport port-security violation</b> {restrict   shutdown}	(Optional) Sets the violation mode, the action to be taken when a security violation is detected, as one of these: <ul style="list-style-type: none"> <li>• <b>restrict</b>—A port security violation restricts data and causes the SecurityViolation counter to increment and send an SNMP trap notification.</li> <li>• <b>shutdown</b>—The interface is error-disabled when a security violation occurs.</li> </ul> <p><b>Note</b> When a secure port is in the error-disabled state, you can bring it out of this state by entering the <b>errdisable recovery cause psecure-violation</b> global configuration command or you can manually reenale it by entering the <b>shutdown</b> and <b>no shut down</b> interface configuration commands.</p> To return the violation mode to the default condition (shutdown mode), use the <b>no switchport port-security violation shutdown</b> command.
<b>Step 7</b> Switch(config-if)# <b>switchport port-security limit rate invalid-source-mac</b> packets_per_sec	Sets the rate limit for bad packets.  Default is 10 pps.

Command	Purpose (continued)
<b>Step 8</b> Switch(config-if)# [no] <b>switchport port-security mac-address</b> <i>mac_address</i>	<p>(Optional) Enters a secure MAC address for the interface. You can use this command to configure a secure MAC addresses. If you configure fewer secure MAC addresses than the maximum, the remaining MAC addresses are dynamically learned.</p> <p>To delete a MAC address from the address table, use the <b>no switchport port-security mac-address</b> <i>mac_address</i> command.</p> <p><b>Note</b> This command only applies to access, PVLAN host, and PVLAN promiscuous mode. For more details on PVLAN, trunk, or regular trunk mode, refer to the “<a href="#">Port Security on Trunk Ports</a>” section on page 38-16.</p>
<b>Step 9</b> Switch(config-if)# [no] <b>switchport port-security mac-address sticky</b>	<p>(Optional) Enable sticky learning on the interface.</p> <p>To disable sticky learning on an interface, use the <b>no switchport port-security mac-address sticky</b> command. The interface converts the sticky secure MAC addresses to dynamic secure addresses.</p>
<b>Step 10</b> Switch(config-if)# [no] <b>switchport port-security mac-address</b> <i>mac_address</i> <b>sticky</b> [ <b>vlan</b> [ <b>voice</b>   <b>access</b> ]]	<p>Specifies the sticky mac-address for the interface.</p> <p>When you specify the <b>vlan</b> keyword, the mac-address becomes sticky in the specified VLAN.</p> <p>To delete a sticky secure MAC addresses from the address table, use the <b>no switchport port-security mac-address</b> <i>mac_address</i> <b>sticky</b> command. To convert sticky to dynamic addresses, use the <b>no switchport port-security mac-address sticky</b> command.</p> <p><b>Note</b> This command only applies to access, PVLAN host, and PVLAN promiscuous mode. For more details on PVLAN or trunk or regular trunk mode, refer to the “<a href="#">Port Security on Trunk Ports</a>” section on page 38-16.</p>
<b>Step 11</b> Switch(config-if)# <b>end</b>	Returns to privileged EXEC mode.
<b>Step 12</b> Switch# <b>show port-security address</b> <b>interface</b> <i>interface_id</i> Switch# <b>show port-security address</b>	Verifies your entries.

**Note**

To clear dynamically learned port security MAC addresses in the CAM table, use the **clear port-security dynamic** command. The **address** keyword enables you to clear a secure MAC addresses. The **interface** keyword enables you to clear all secure addresses on any interface (including any port channel interface). The **VLAN** keyword allows you to clear port security MACs on a per-VLAN per-port basis.

## Examples

The following examples are provided:

- [Example 1: Setting Maximum Number of Secure Addresses, page 38-10](#)
- [Example 2: Setting a Violation Mode, page 38-10](#)
- [Example 3: Setting the Aging Timer, page 38-11](#)
- [Example 4: Setting the Aging Timer Type, page 38-11](#)
- [Example 5: Configuring a Secure MAC Address, page 38-11](#)
- [Example 6: Configuring Sticky Port Security, page 38-12](#)
- [Example 7: Setting a Rate Limit for Bad Packets, page 38-13](#)
- [Example 8: Clearing Dynamic Secure MAC Addresses, page 38-13](#)

### Example 1: Setting Maximum Number of Secure Addresses

This example shows how to enable port security on the Fast Ethernet interface 3/12 and how to set the maximum number of secure addresses to 5. The violation mode is the default, and no secure MAC addresses are configured.

```
Switch# configure terminal
Enter configuration commands, one per line. End with CNTL/Z.
Switch(config)# interface fastethernet 3/12
Switch(config-if)# switchport mode access
Switch(config-if)# switchport port-security
Switch(config-if)# switchport port-security maximum 5
Switch(config-if)# switchport port-security mac-address sticky
Switch(config-if)# end
Switch# show port-security interface fastethernet 3/12
Port Security           : Enabled
Port Status             : Secure-up
Violation Mode          : Shutdown
Aging Time              : 0 mins
Aging Type              : Absolute
SecureStatic Address Aging : Enabled
Maximum MAC Addresses   : 5
Total MAC Addresses     : 0
Configured MAC Addresses : 0
Sticky MAC Addresses    : 0
Last Source Address:Vlan : 0000.0000.0000:0
Security Violation Count : 0
```

### Example 2: Setting a Violation Mode

This example shows how to set the violation mode on the Fast Ethernet interface 3/12 to restrict.

```
Switch# configure terminal
Enter configuration commands, one per line. End with CNTL/Z.
Switch(config)# interface fastethernet 3/12
Switch(config-if)# switchport port-security violation restrict
Switch(config-if)# end
Switch#
```

SNMP traps can be enabled with a rate-limit to detect port-security violations due to restrict mode. The following example shows how to enable traps for port-security with a rate of 5 traps per second:

```
Switch# configure terminal
Enter configuration commands, one per line. End with CNTL/Z.
Switch(config)# snmp-server enable traps port-security trap-rate 5
Switch(config)# end
Switch#
```

### Example 3: Setting the Aging Timer

This example shows how to set the aging time to 2 hours (120 minutes) for the secure addresses on the Fast Ethernet interface 5/1:

```
Switch# configure terminal
Enter configuration commands, one per line. End with CNTL/Z.
Switch(config)# interface fastethernet 5/1
Switch(config-if)# switchport port-security aging time 120
Switch(config-if)# end
Switch#
```

This example shows how to set the aging time to 2 minutes:

```
Switch(config-if)# switchport port-security aging time 2
```

You can verify the previous commands with the **show port-security interface** command.

### Example 4: Setting the Aging Timer Type

This example shows how to set the aging timer type to Inactivity for the secure addresses on the Fast Ethernet interface 3/5:

```
Switch# configure terminal
Enter configuration commands, one per line. End with CNTL/Z.
Switch(config)# interface fastethernet 3/5
Switch(config-if)# switchport port-security aging type inactivity
Switch(config-if)# end
Switch# show port-security interface fastethernet 3/5
Port Security           : Enabled
Port Status             : Secure-up
Violation Mode         : Shutdown
Aging Time              : 0 mins
Aging Type              : Inactivity
SecureStatic Address Aging : Disabled
Maximum MAC Addresses  : 1
Total MAC Addresses    : 0
Configured MAC Addresses : 0
Sticky MAC Addresses   : 0
Last Source Address:Vlan : 0000.0000.0000:0
Security Violation Count : 0
```

### Example 5: Configuring a Secure MAC Address

This example shows how to configure a secure MAC address on Fast Ethernet interface 5/1 and to verify the configuration:

```
Switch# configure terminal
Enter configuration commands, one per line. End with CNTL/Z.
Switch(config)# interface fastethernet 5/1
Switch(config-if)# switchport mode access
```

```
Switch(config-if)# switchport port-security
Switch(config-if)# switchport port-security maximum 10
Switch(config-if)# switchport port-security mac-address 0000.0000.0003 (Static secure MAC)
Switch(config-if)# end
Switch#show port address
Secure Mac Address Table
-----
Vlan      Mac Address      Type                Ports      Remaining Age
-----  -
1         0000.0000.0003   SecureConfigured    Fa5/1      -

-----
Total Addresses in System (excluding one mac per port)    : 2
Max Addresses limit in System (excluding one mac per port) : 3072
```

## Example 6: Configuring Sticky Port Security

This example shows how to configure a sticky MAC address on Fast Ethernet interface 5/1 and to verify the configuration:

```
Switch# configure terminal
Enter configuration commands, one per line. End with CNTL/Z.
Switch(config)# interface fa5/1
Switch(config-if)# switchport mode access
Switch(config-if)# switchport port-security
Switch(config-if)# switchport port-security mac-address sticky
Switch(config-if)# switchport port-security maximum 5
Switch(config-if)# end
```



### Note

Sending traffic to the ports causes the system to configure the port with sticky secure addresses.

```
Switch# show port-security address
Secure Mac Address Table
-----
Vlan      Mac Address      Type                Ports      Remaining Age
-----  -
1         0000.0000.0001   SecureSticky        Fa5/1      -
1         0000.0000.0002   SecureSticky        Fa5/1      -
1         0000.0000.0003   SecureSticky        Fa5/1      -

-----
Total Addresses in System (excluding one mac per port)    : 2
Max Addresses limit in System (excluding one mac per port) : 3072
Switch# show running-config interface fastEthernet 5/1
Building configuration...

Current configuration : 344 bytes
!
interface FastEthernet5/1
 switchport mode access
 switchport port-security
 switchport port-security maximum 5
 switchport port-security mac-address sticky
 switchport port-security mac-address sticky 0000.0000.0001
 switchport port-security mac-address sticky 0000.0000.0002
 switchport port-security mac-address sticky 0000.0000.0003
end

Switch#
```

## Example 7: Setting a Rate Limit for Bad Packets

The following example shows how to configure rate limit for invalid source packets on Fast Ethernet interface 5/1:

```
Switch# configure terminal
Enter configuration commands, one per line. End with CNTL/Z.
Switch(config)# interface fastethernet 5/1
Switch(config-if)# switchport port-security limit rate invalid-source-mac 100
Switch(config-if)# end
Switch#
```

The following example shows how to configure rate limit for invalid source packets on Fast Ethernet interface 5/1:

```
Switch# configure terminal
Enter configuration commands, one per line. End with CNTL/Z.
Switch(config)# interface fastethernet 5/1
Switch(config-if)# switchport port-security limit rate invalid-source-mac none
Switch(config-if)# end
Switch#
```

## Example 8: Clearing Dynamic Secure MAC Addresses

The following example shows how to clear a dynamic secure MAC address:

```
Switch# clear port-security dynamic address 0000.0001.0001
```

The following example shows how to clear all dynamic secure MAC addresses on Fast Ethernet interface 2/1:

```
Switch# clear port-security dynamic interface fa2/1
```

The following example shows how to clear all dynamic secure MAC addresses in the system:

```
Switch# clear port-security dynamic
```

## Port Security on a Private VLAN Port

You can configure port security on a private VLAN port to take advantage of private VLAN functionality as well as to limit the number of MAC addresses.



### Note

---

This section follows the same configuration model that was presented for access ports.

---

These sections describe how to configure trunk port security on host and promiscuous ports:

- [Configuring Port Security on an Isolated Private VLAN Host Port, page 38-14](#)
- [Example of Port Security on an Isolated Private VLAN Host Port, page 38-15](#)
- [Configuring Port Security on a Private VLAN Promiscuous Port, page 38-15](#)
- [Example of Port Security on a Private VLAN Promiscuous Port, page 38-16](#)

## Configuring Port Security on an Isolated Private VLAN Host Port

Figure 38-1 illustrates a typical topology for port security implemented on private VLAN host ports. In this topology, the PC connected through port a on the switch can communicate only with the router connected through the promiscuous port on the switch. The PC connected through port a cannot communicate with the PC connected through port b.

Figure 38-1 Port Security on Isolated Private VLAN Host Ports

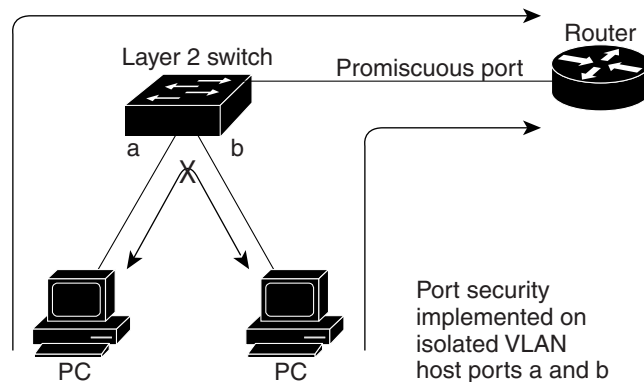

### Note

Dynamic addresses secured on an isolated private VLAN host port on private VLANs are secured on the secondary VLANs, and not primary VLANs.

To configure port security on an isolated private VLAN host port, perform this task:

	Command	Purpose
Step 1	Switch# <b>configure terminal</b>	Enter global configuration mode.
Step 2	Switch(config)# <b>vlan sec_vlan_id</b>	Specifies a secondary VLAN.
Step 3	Switch(config-vlan)# <b>private-vlan isolated</b>	Sets the private VLAN mode to isolated.
Step 4	Switch(config-vlan)# <b>exit</b>	Returns to global configuration mode.
Step 5	Switch(config)# <b>vlan pri_vlan_id</b>	Specifies a primary VLAN.
Step 6	Switch(config-vlan)# <b>private-vlan primary</b>	Specifies the VLAN as the primary private VLAN.
Step 7	Switch(config-vlan)# <b>private-vlan association add sec_vlan_id</b>	Creates an association between a secondary VLAN and a primary VLAN.
Step 8	Switch(config-vlan)# <b>exit</b>	Returns to global configuration mode.
Step 9	Switch(config)# <b>interface interface_id</b>	Enters interface configuration mode and specifies the physical interface to configure.
Step 10	Switch(config-if)# <b>switchport mode private-vlan host</b>	Specifies that the ports with a valid private VLAN trunk association become active host private VLAN trunk ports.
Step 11	Switch(config-if)# <b>switchport private-vlan host-association primary_vlan secondary_vlan</b>	Establishes a host association on an isolated host port.
Step 12	Switch(config-if)# [ <b>no</b> ] <b>switchport port-security</b>	Enables port security on the interface.

	Command	Purpose (continued)
Step 13	Switch(config-if)# <b>end</b>	Returns to privileged EXEC mode.
Step 14	Switch# <b>show port-security address</b> interface <i>interface_id</i> Switch# <b>show port-security address</b>	Verifies your entries.

## Example of Port Security on an Isolated Private VLAN Host Port

The following example shows how to configure port security on an isolated private VLAN host port, Fast Ethernet interface 3/12:

```
Switch# configure terminal
Enter configuration commands, one per line. End with CNTL/Z.
Switch(config)# vlan 6
Switch(config-vlan)# private-vlan isolated
Switch(config-vlan)# exit
Switch(config)# vlan 3
Switch(config-vlan)# private-vlan primary
Switch(config-vlan)# private-vlan association add 6
Switch(config-vlan)# exit
Switch(config)# interface fastethernet 3/12
Switch(config-if)# switchport mode private-vlan host
Switch(config-if)# switchport private-vlan association host 3 6
Switch(config-if)# switchport port-security
Switch(config-if)# end
```

## Configuring Port Security on a Private VLAN Promiscuous Port

To configure port security on a private VLAN promiscuous port, perform this task:

	Command	Purpose
Step 1	Switch# <b>configure terminal</b>	Enter global configuration mode.
Step 2	Switch(config)# <b>vlan sec_vlan_id</b>	Specifies the VLAN.
Step 3	Switch(config-vlan)# <b>private-vlan isolated</b>	Sets the private VLAN mode to isolated.
Step 4	Switch(config-vlan)# <b>exit</b>	Returns to global configuration mode.
Step 5	Switch(config)# <b>vlan pri_vlan_id</b>	Specifies the VLAN.
Step 6	Switch(config-vlan)# <b>private-vlan primary</b>	Designates the VLAN as the primary private VLAN.
Step 7	Switch(config-vlan)# <b>private-vlan association add sec_vlan_id</b>	Creates an association between a secondary VLAN and a primary VLAN.
Step 8	Switch(config-vlan)# <b>exit</b>	Returns to global configuration mode.
Step 9	Switch(config)# <b>interface interface_id</b>	Enters interface configuration mode and specifies the physical interface to configure.
Step 10	Switch(config-if)# <b>switchport mode private-vlan promiscuous</b>	Specifies that the ports with a valid PVLAN mapping become active promiscuous ports.
Step 11	Switch(config-if)# <b>switchport private-vlan mapping primary_vlan secondary_vlan</b>	Configures a private VLAN for the promiscuous ports
Step 12	Switch(config-if)# <b>switchport port-security</b>	Enables port security on the interface.

	Command	Purpose (continued)
Step 13	Switch(config-if)# <b>end</b>	Returns to privileged EXEC mode.
Step 14	Switch# <b>show port-security address</b> interface <i>interface_id</i> Switch# <b>show port-security address</b>	Verifies your entries.

## Example of Port Security on a Private VLAN Promiscuous Port

The following example shows how to configure port security on a private VLAN promiscuous port, Fast Ethernet interface 3/12:

```
Switch# configure terminal
Enter configuration commands, one per line. End with CNTL/Z.
Switch(config)# vlan 6
Switch(config-vlan)# private-vlan isolated
Switch(config-vlan)# exit
Switch(config)# vlan 3
Switch(config-vlan)# private-vlan primary
Switch(config-vlan)# private-vlan association add 6
Switch(config-vlan)# exit
Switch(config)# interface fastethernet 3/12
Switch(config-if)# switchport mode private-vlan promiscuous
Switch(config-if)# switchport mode private-vlan mapping 3 6
Switch(config-if)# switchport port-security
Switch(config-if)# end
```

## Port Security on Trunk Ports

You might want to configure port security on trunk ports in metro aggregation to limit the number of MAC addresses per VLAN. Trunk port security extends port security to trunk ports. It restricts the allowed MAC addresses or the maximum number of MAC addresses to individual VLANs on a trunk port. Trunk port security enables service providers to block the access from a station with a different MAC address than the ones specified for that VLAN on that trunk port. Trunk port security is also supported on private VLAN trunk ports.



### Note

Port security can be enabled on a Layer 2 port channel interface configured in mode. The port security configuration on an EtherChannel is kept independent of the configuration of any physical member ports.

These sections describe how to configure trunk port security:

- [Configuring Trunk Port Security, page 38-16](#)
- [Examples of Trunk Port Security, page 38-18](#)
- [Trunk Port Security Guidelines and Restrictions, page 38-20](#)

## Configuring Trunk Port Security

Trunk port security is used when a Catalyst 4500 series switch has a dot1q or isl trunk attached to a neighborhood Layer 2 switch. This may be used, for example, in metro aggregation networks ([Figure 38-2](#)).

Figure 38-2 Trunk Port Security



You can configure various port security related parameters on a per-port per-VLAN basis.

**Note**

The steps involved in configuring port security parameters is similar to those for access ports. In addition to those steps, the following per-port per-VLAN configuration steps are supported for trunk ports.

To configure port security related parameters on a per-VLAN per-port basis, perform this task:

	Command	Purpose
<b>Step 1</b>	Switch(config)# <b>interface</b> <i>interface_id</i> <b>interface</b> <i>port-channel port_channel_number</i>	Enters interface configuration mode and specifies the interface to configure.  <b>Note</b> The interface can be a Layer 2 port channel logical interface.
<b>Step 2</b>	Switch(config-if)# <b>switchport trunk encapsulation dot1q</b>	Sets the trunk encapsulation format to 802.1Q.
<b>Step 3</b>	Switch(config-if)# <b>switchport mode trunk</b>	Sets the interface mode.  <b>Note</b> An interface in the default mode (dynamic desirable) cannot be configured as a secure port.

	Command	Purpose (continued)
Step 4	Switch(config-if)# <b>switchport port-security maximum value vlan</b>	Configures a maximum number of secure mac-addresses for each VLAN on the interface that are not explicitly configured with a maximum mac-address limit. (See the “Maximum Number of Secure MAC Addresses” section on page 38-4.)
Step 5	Switch(config-if)# <b>vlan-range range</b>	Enters VLAN range sub-mode. <b>Note</b> You can specify single or multiple VLANs.
Step 6	Switch(config-if-vlan-range)# <b>port-security maximum value</b>	Configures a maximum number of secure MAC addresses for each VLAN.
Step 7	Switch(config-if-vlan-range)# <b>no port-security maximum</b>	Removes a maximum number of secure MAC addresses configuration for all the VLANs. Subsequently, the maximum value configured on the port will be used for all the VLANs.
Step 8	Switch(config-if-vlan-range)# <b>[no] port-security mac-address mac_address</b>	Configures a secure MAC-address on a range of VLANs.
Step 9	Switch(config-if-vlan-range)# <b>[no] port-security mac-address sticky mac_address</b>	Configures a sticky MAC-address on a range of VLANs.
Step 10	Switch(config-if-vlan-range)# <b>end</b>	Returns to interface configuration mode.
Step 11	Switch(config-if)# <b>end</b>	Returns to privileged EXEC mode.

## Examples of Trunk Port Security

The following examples are provided:

- [Example 1: Configuring a Maximum Limit of Secure MAC Addresses for all VLANs, page 38-18](#)
- [Example 2: Configuring a Maximum Limit of Secure MAC Addresses for Specific VLANs, page 38-19](#)
- [Example 3: Configuring Secure MAC Addresses in a VLAN Range, page 38-19](#)

### Example 1: Configuring a Maximum Limit of Secure MAC Addresses for all VLANs

This example shows how to configure a secure MAC-address and a maximum limit of secure MAC addresses on Gigabit Ethernet interface 1/1 for all VLANs:

```
Switch# configure terminal
Enter configuration commands, one per line. End with CNTL/Z.
Switch(config)# interface g1/1
Switch(config-if)# switchport trunk encapsulation dot1q
Switch(config-if)# sw mode trunk
Switch(config-if)# switchport port-security
Switch(config-if)# switchport port-security maximum 3

Switch# show port-security in gi1/1 vlan
Default maximum: 3
VLAN Maximum Current
   1         3      0
   2         3      0
   3         3      0
```

```

      4      3      0
      5      3      0
      6      3      0
Switch#

Switch# show running interface g1/1
Building configuration...

Current configuration : 161 bytes
!
interface GigabitEthernet1/1
  switchport trunk encapsulation dot1q
  switchport mode trunk
  switchport port-security
  switchport port-security maximum 3 vlan
end

```

## Example 2: Configuring a Maximum Limit of Secure MAC Addresses for Specific VLANs

This example shows how to configure a secure MAC-address on interface g1/1 in a specific VLAN or range of VLANs:

```

Switch# configure terminal
Enter configuration commands, one per line. End with CNTL/Z.
Switch(config)# interface g1/1
Switch(config-if)# switchport trunk encapsulation dot1q
Switch(config-if)# sw mode trunk
Switch(config-if)# switchport port-security
Switch(config-if)# vlan-range 2-6
Switch(config-if-vlan-range)# port-security maximum 3
Switch(config-if)# exit

Switch# show port-security interface g1/1 vlan
Default maximum: not set, using 3072
VLAN Maximum Current
   2      3      0
   3      3      0
   4      3      0
   5      3      0
   6      3      0
Switch#

```

## Example 3: Configuring Secure MAC Addresses in a VLAN Range

This example shows how to configure a secure MAC-address in a VLAN on interface g1/1:

```

Switch# configure terminal
Enter configuration commands, one per line. End with CNTL/Z.
Switch(config)# interface g1/1
Switch(config-if)# switchport trunk encapsulation dot1q
Switch(config-if)# sw mode trunk
Switch(config-if)# switchport port-security
Switch(config-if)# switchport port-security mac-address sticky
Switch(config-if)# vlan-range 2-6
Switch(config-if-vlan-range)# port-security mac-address 1.1.1
Switch(config-if-vlan-range)# port-security mac-address sticky 1.1.2
Switch(config-if-vlan-range)# port-security mac-address sticky 1.1.3
Switch(config-if-vlan-range)# exit

```

```
Switch# show port-security interface g1/1 address vlan 2-4
Secure Mac Address Table
-----
Vlan    Mac Address      Type                Ports    Remaining Age
-----
2       0001.0001.0001  SecureConfigured   Gi1/1    -
2       0001.0001.0002  SecureSticky       Gi1/1    -
2       0001.0001.0003  SecureSticky       Gi1/1    -
3       0001.0001.0001  SecureConfigured   Gi1/1    -
3       0001.0001.0002  SecureSticky       Gi1/1    -
3       0001.0001.0003  SecureSticky       Gi1/1    -
4       0001.0001.0001  SecureConfigured   Gi1/1    -
4       0001.0001.0002  SecureSticky       Gi1/1    -
4       0001.0001.0003  SecureSticky       Gi1/1    -
-----
Total Addresses: 9

Switch#
```

## Trunk Port Security Guidelines and Restrictions

Follow these guidelines when configuring port security related parameters on a per-port per-VLAN basis:

- A secure MAC-address cannot be configured on a VLAN that is not allowed on a regular trunk port.
- The configuration on the primary VLAN on the private VLAN trunk is not allowed. The CLI is rejected and an error message is displayed.
- If a specific VLAN on a port is not configured with a maximum value (directly or indirectly), the maximum configured for the port is used for that VLAN. In this situation, the maximum number of addresses that can be secured on this VLAN is limited to the maximum value configured on the port.

Each VLAN can be configured with a maximum count that is greater than the value configured on the port. Also, the sum of the maximum configured values for all the VLANs can exceed the maximum configured for the port. In either of these situations, the number of MAC addresses secured on each VLAN is limited to the lesser of the VLAN configuration maximum and the port configuration maximum. Also, the number of addresses secured on the port across all VLANs cannot exceed a maximum that is configured on the port.

- For private VLAN trunk ports, the VLAN on which the configuration is being performed must be in either the allowed VLAN list of the private VLAN trunk or the secondary VLAN list in the association pairs. (The CLI is rejected if this condition is not met.) The allowed VLAN list on a private VLAN trunk is intended to hold the VLAN-IDs of all the regular VLANs that are allowed on the private VLAN trunk.
- Removal of an association pair from a PVLAN trunk causes all static and sticky addresses associated with the secondary VLAN of the pair to be removed from the running configuration. Dynamic addresses associated with the secondary VLAN are deleted from the system.

Similarly, when a VLAN is removed from the list of allowed PVLAN trunks, the addresses associated with that VLAN are removed.



### Note

For a regular or private VLAN trunk port, if the VLAN is removed from the allowed VLAN list, all the addresses associated with that VLAN are removed.

## Port Mode Changes

Generally, when a port mode changes, all dynamic addresses associated with that port are removed. All static or sticky addresses and other port security parameters configured on the native VLAN are moved to the native VLAN of the port in the new mode. All the addresses on the non-native VLANs are removed.

The native VLAN refers to the following VLAN on the specified port type:

Port Type	Native VLAN
access	access VLAN
trunk	native VLAN
isolated	secondary VLAN (from host association)
promiscuous	primary VLAN (from mapping)
private VLAN trunk	private VLAN trunk native VLAN
.1Q tunnel	access VLAN

For example, when the mode changes from access to private VLAN trunk, all the static or sticky addresses configured on the access VLAN of the access port are moved to the private VLAN native VLAN of the private VLAN trunk port. All other addresses are removed.

Similarly, when the mode changes from private VLAN trunk to access mode, all the static or sticky addresses configured on the private VLAN native VLAN are moved to the access VLAN of the access port. All other addresses are removed.

When a port is changed from trunk to private VLAN trunk, addresses associated with a VLAN on the trunk are retained if that VLAN is present in the allowed list of private VLAN trunk or the secondary VLAN of an association on the private VLAN trunk. If the VLAN is not present in either of them, the address is removed from the running configuration.

When a port is changed from private VLAN trunk to trunk, a static or sticky address is retained if the VLAN associated with the address is present in the allowed VLAN list of the trunk. If the VLAN is not present in the allowed list, the address is removed from running configuration.

## Port Security on Voice Ports

You might want to configure port security in an IP Telephony environment when a port is configured with a data VLAN for a PC and a voice VLAN for a Cisco IP Phone.

These sections describe how to configure port security on voice ports:

- [Configuring Port Security on Voice Ports, page 38-22](#)
- [Examples of Voice Port Security, page 38-24](#)
- [Voice Port Security Guidelines and Restrictions, page 38-26](#)

## Configuring Port Security on Voice Ports

To configure port security on a voice port, perform this task:

	Command	Purpose
Step 1	Switch(config)# <b>interface</b> <i>interface_id</i>	Enters interface configuration mode and specifies the physical interface to configure.
Step 2	Switch(config-if)# <b>switchport mode access</b>	Sets the interface mode. <b>Note</b> An interface in the default mode (dynamic desirable) cannot be configured as a secure port.
Step 3	Switch(config-if)# [ <b>no</b> ] <b>switchport port-security</b>	Enables port security on the interface. To return the interface to the default condition as nonsecure port, use the <b>no switchport port-security</b> command.
Step 4	Switch(config-if)# [ <b>no</b> ] <b>switchport port-security violation</b> { <b>restrict</b>   <b>shutdown</b> }	(Optional) Sets the violation mode, the action to be taken when a security violation is detected, as one of these: <ul style="list-style-type: none"> <li>• <b>restrict</b>—A port security violation restricts data and causes the SecurityViolation counter to increment and send an SNMP trap notification.</li> <li>• <b>shutdown</b>—The interface is error-disabled when a security violation occurs.</li> </ul> <b>Note</b> When a secure port is in the error-disabled state, you can bring it out of this state by entering the <b>errdisable recovery cause psecure-violation</b> global configuration command or you can manually reenab it by entering the <b>shutdown</b> and <b>no shut down</b> interface configuration commands. To return the violation mode to the default condition (shutdown mode), use the <b>no switchport port-security violation shutdown</b> command.
Step 5	Switch(config-if)# <b>switchport port-security limit rate invalid-source-mac</b> <i>packets_per_sec</i>	Sets the rate limit for bad packets. Default is 10 pps.

Command	Purpose (continued)
<p><b>Step 6</b> Switch(config-if)# [no] <b>switchport port-security mac-address</b> <i>mac_address</i> [vlan {voice   access}]</p>	<p>(Optional) Specifies a secure MAC address for the interface.</p> <p>When you specify the <b>vlan</b> keyword, addresses are configured in the specified VLAN.</p> <ul style="list-style-type: none"> <li>• <b>voice</b>—MAC address is configured in the voice VLAN.</li> <li>• <b>access</b>—MAC address is configured in the access VLAN.</li> </ul> <p>You can use this command to configure secure MAC addresses. If you configure fewer secure MAC addresses than the maximum, the remaining MAC addresses are dynamically learned.</p> <p>To delete a MAC address from the address table, use the <b>no switchport port-security mac-address</b> <i>mac_address</i> command.</p> <p><b>Note</b> This command only applies to access, PVLAN host, and PVLAN promiscuous mode. For more details on PVLAN, trunk, or regular trunk mode, refer to the “<a href="#">Port Security on Trunk Ports</a>” section on page 38-16.</p>
<p><b>Step 7</b> Switch(config-if)# [no] <b>switchport port-security mac-address sticky</b></p>	<p>(Optional) Enable sticky learning on the interface.</p> <p>To disable sticky learning on an interface, use the <b>no switchport port-security mac-address sticky</b> command. The interface converts the sticky secure MAC addresses to dynamic secure addresses.</p>
<p><b>Step 8</b> Switch(config-if)# [no] <b>switchport port-security mac-address</b> <i>mac_address</i> <b>sticky</b> [vlan {voice   access}]</p>	<p>Specifies the sticky mac-address for the interface.</p> <p>When you specify the <b>vlan</b> keyword, the mac-address becomes sticky in the specified VLAN.</p> <ul style="list-style-type: none"> <li>• <b>voice</b>—MAC address becomes sticky in the voice VLAN.</li> <li>• <b>access</b>—MAC address becomes sticky in the access VLAN.</li> </ul> <p>To delete a sticky secure MAC addresses from the address table, use the <b>no switchport port-security mac-address</b> <i>mac_address</i> <b>sticky</b> command. To convert sticky to dynamic addresses, use the <b>no switchport port-security mac-address sticky</b> command.</p> <p><b>Note</b> This command only applies to access, PVLAN host, and PVLAN promiscuous mode. For more details on PVLAN or trunk or regular trunk mode, refer to the “<a href="#">Port Security on Trunk Ports</a>” section on page 38-16.</p>

	Command	Purpose (continued)
Step 9	Switch(config-if)# <b>end</b>	Returns to privileged EXEC mode.
Step 10	Switch# <b>show port-security address</b> Switch# <b>show port-security address</b> Switch# <b>show port-security address</b>	Verifies your entries.

**Note**

To clear dynamically learned port security MAC addresses in the CAM table, use the **clear port-security dynamic** command. The **address** keyword enables you to clear a secure MAC addresses. The **interface** keyword enables you to clear all secure addresses on an interface (including any port channel interface). The **VLAN** keyword allows you to clear port security MACs on a per-VLAN per-port basis.

**Note**

Each port-security configured interface accepts one mac-address by default. With port-security port level port-security configuration takes precedence over VLAN level port-security configuration. So, to allow one mac-address each for voice and data VLAN, configure the port for a maximum of greater than or equal to two addresses.

## Examples of Voice Port Security

The following examples are provided:

- [Example 1: Configuring Maximum MAC Addresses for Voice and Data VLANs, page 38-24](#)
- [Example 2: Configuring Sticky MAC Addresses for Voice and Data VLANs, page 38-25](#)

### Example 1: Configuring Maximum MAC Addresses for Voice and Data VLANs

This example shows how to designate a maximum of one MAC address for a voice VLAN (for a Cisco IP Phone, let's say) and one MAC address for the data VLAN (for a PC, let's say) on Fast Ethernet interface 5/1 and to verify the configuration:

```
Switch# configure terminal
Enter configuration commands, one per line. End with CNTL/Z.
Switch(config)# interface fa5/1
Switch(config-if)# switchport mode access
Switch(config-if)# switchport port-security
Switch(config-if)# switchport port-security maximum 2
Switch(config-if)# switchport port-security mac-address sticky
Switch(config-if)# switchport port-security maximum 1 vlan voice
Switch(config-if)# switchport port-security maximum 1 vlan access
Switch(config-if)# end
```

**Note**

Sending traffic to the ports causes the system to configure the port with sticky secure addresses.

```
Switch# show port-security address
      Secure Mac Address Table
-----
Vlan    Mac Address      Type                Ports    Remaining Age
-----  -
1       0000.0000.0001   SecureSticky        Fa5/1    -
3       0000.0000.0004   SecureSticky        Fa5/1    -
-----

Total Addresses in System (excluding one mac per port)    : 1
Max Addresses limit in System (excluding one mac per port) : 3072

Switch# show running-config interface fastEthernet 5/1
Building configuration...

Current configuration : 344 bytes
!
interface FastEthernet5/1
 switchport mode access
 switchport voice vlan 3
 switchport port-security
 switchport port-security maximum 1 vlan voice
 switchport port-security maximum 3072
 switchport port-security maximum 1 vlan access
 switchport port-security mac-address sticky
 switchport port-security mac-address sticky 0000.0000.0001
 switchport port-security mac-address sticky 0000.0000.0004 vlan voice
end

Switch#
```

## Example 2: Configuring Sticky MAC Addresses for Voice and Data VLANs

This example shows how to configure sticky MAC addresses for voice and data VLANs on Fast Ethernet interface 5/1 and to verify the configuration:

```
Switch# configure terminal
Enter configuration commands, one per line. End with CNTL/Z.
Switch(config)# interface fa5/1
Switch(config-if)# switchport mode access
Switch(config-if)# switchport port-security
Switch(config-if)# switchport port-security maximum 3072
Switch(config-if)# switchport port-security mac-address sticky 0000.0000.obob vlan voice
Switch(config-if)# switchport port-security mac-address sticky 0000.0000.0005 vlan access
Switch(config-if)# end
```

**Note**

Sending traffic to the ports causes the system to configure the port with sticky secure addresses.

```
Switch# show port-security address
      Secure Mac Address Table
-----
Vlan    Mac Address      Type                Ports    Remaining Age
-----  -
1       0000.0000.0001   SecureSticky        Fa5/1    -
1       0000.0000.0002   SecureSticky        Fa5/1    -
1       0000.0000.0003   SecureSticky        Fa5/1    -
-----
```

```

      3    0000.0000.0004    SecureSticky    Fa5/1    -
      1    0000.0000.0005    SecureSticky    Fa5/1    -
      3    0000.0000.0b0b    SecureSticky    Fa5/1    -
-----
Total Addresses in System (excluding one mac per port)    : 5
Max Addresses limit in System (excluding one mac per port) : 3072

Switch# show running-config interface fastEthernet 5/1
Building configuration...

Current configuration : 344 bytes
!
interface FastEthernet5/1
 switchport mode access
 switchport voice vlan 3
 switchport port-security
 switchport port-security maximum 3072
 switchport port-security maximum 5 vlan voice
 switchport port-security mac-address sticky
 switchport port-security mac-address sticky 0000.0000.0001
 switchport port-security mac-address sticky 0000.0000.0002
 switchport port-security mac-address sticky 0000.0000.0003
 switchport port-security mac-address sticky 0000.0000.0004 vlan voice
 switchport port-security mac-address sticky 0000.0000.0005
 switchport port-security mac-address sticky 0000.0000.0b0b vlan voice
end

Switch#

```

## Voice Port Security Guidelines and Restrictions

Port security as implemented on voice ports behaves the same as port security on access ports:

- You can configure sticky port security on voice ports. If sticky port security is enabled on a voice port, addresses secured on data and voice VLANs are secured as sticky addresses.
- You can configure maximum secure addresses per VLAN. You can set a maximum for either the data VLAN or the voice VLAN. You can also set a maximum per-port, just as with access ports.
- You can configure port security MAC addresses on a per-VLAN basis on either the data or voice VLANs.
- Prior to Cisco IOS Release 12.2(31)SG, you required three MAC addresses as the maximum parameter to support an IP Phone and a PC. With Cisco IOS Release 12.2(31)SG and later releases, the maximum parameter must be configured to two, one for the phone and one for the PC.

# Displaying Port Security Settings

Use the **show port-security** command to display port-security settings for an interface or for the switch.

To display traffic control information, perform one or more of these tasks:

Command	Purpose
Switch# <b>show interface status err-disable</b>	Displays interfaces that have been error-disabled along with the cause for which they were disabled.
Switch# <b>show port-security</b> [ <b>interface</b> <i>interface_id</i>   <b>interface</b> <i>port_channel port_channel_number</i> ]	Displays port security settings for the switch or for the specified interface, including the maximum allowed number of secure MAC addresses for each interface, the number of secure MAC addresses on the interface, the number of security violations that have occurred, and the violation mode.  The interface can be a port channel logical interface.
Switch# <b>show port-security</b> [ <b>interface</b> <i>interface_id</i>   <b>interface</b> <i>port_channel port_channel_number</i> ] <b>address</b>	Displays all secure MAC addresses configured on all switch interfaces or on a specified interface with aging information for each address.
Switch# <b>show port-security</b> [ <b>interface</b> <i>interface_id</i>   <b>interface</b> <i>port_channel port_channel_number</i> ] <b>vlan</b> <i>vlan_list</i>	Displays the maximum allowed number of secure MAC addresses and the current number of secure MAC addresses on a specific VLAN-list and a specific interface.
Switch# <b>show port-security</b> [ <b>interface</b> <i>interface_id</i>   <b>interface</b> <i>port_channel port_channel_number</i> ] [ <b>address</b> [ <b>vlan</b> <i>vlan_list</i> ]]	Displays all secure MAC addresses configured on a specific VLAN-list and a specific interface.

## Examples

The following examples are provided:

- [Example 1: Displaying Security Settings for the Entire Switch, page 38-28](#)
- [Example 2: Displaying Security Settings for an Interface, page 38-28](#)
- [Example 3: Displaying all Secure Addresses for the Entire Switch, page 38-28](#)
- [Example 4: Displaying a Maximum Number of MAC Addresses on an Interface, page 38-29](#)
- [Example 5: Displaying Security Settings on an Interface for a VLAN Range, page 38-29](#)
- [Example 6: Displaying Secured MAC Addresses and Aging Information on an Interface, page 38-29](#)
- [Example 7: Displaying Secured MAC Addresses for a VLAN Range on an Interface, page 38-30](#)

## Example 1: Displaying Security Settings for the Entire Switch

This example shows how to display port security settings for the entire switch:

```
Switch# show port-security
Secure Port  MaxSecureAddr  CurrentAddr  SecurityViolation  Security Action
              (Count)          (Count)      (Count)
-----
    Fa3/1          2             2             0             Restrict
    Fa3/2          2             2             0             Restrict
    Fa3/3          2             2             0             Shutdown
    Fa3/4          2             2             0             Shutdown
    Fa3/5          2             2             0             Shutdown
    Fa3/6          2             2             0             Shutdown
    Fa3/7          2             2             0             Shutdown
    Fa3/8          2             2             0             Shutdown
    Fa3/10         1             0             0             Shutdown
    Fa3/11         1             0             0             Shutdown
    Fa3/12         1             0             0             Restrict
    Fa3/13         1             0             0             Shutdown
    Fa3/14         1             0             0             Shutdown
    Fa3/15         1             0             0             Shutdown
    Fa3/16         1             0             0             Shutdown
    Po2            3             0             0             Shutdown
-----
Total Addresses in System (excluding one mac per port)      :8
Max Addresses limit in System (excluding one mac per port) :3072
Global SNMP trap control for port-security                 :20 (traps per second)
```

## Example 2: Displaying Security Settings for an Interface

This example shows how to display port security settings for Fast Ethernet interface 5/1:

```
Switch# show port-security interface fastethernet 5/1
Port Security          : Enabled
Port Status            : Secure-up
Violation Mode         : Shutdown
Aging Time              : 0 mins
Aging Type              : Absolute
SecureStatic Address Aging : Disabled
Maximum MAC Addresses  : 1
Total MAC Addresses    : 1
Configured MAC Addresses : 0
Sticky MAC Addresses   : 1
Last Source Address:Vlan : 0000.0001.001a:1
Security Violation Count : 0
```

## Example 3: Displaying all Secure Addresses for the Entire Switch

This example shows how to display all secure MAC addresses configured on all switch interfaces:

```
Switch# show port-security address
Secure Mac Address Table
-----
Vlan    Mac Address          Type                Ports    Remaining Age
-----  -
1       0000.0001.0000      SecureConfigured    Fa3/1    15 (I)
1       0000.0001.0001      SecureConfigured    Fa3/1    14 (I)
1       0000.0001.0100      SecureConfigured    Fa3/2    -
1       0000.0001.0101      SecureConfigured    Fa3/2    -
1       0000.0001.0200      SecureConfigured    Fa3/3    -
1       0000.0001.0201      SecureConfigured    Fa3/3    -
```

```

1 0000.0001.0300 SecureConfigured Fa3/4 -
1 0000.0001.0301 SecureConfigured Fa3/4 -
1 0000.0001.1000 SecureDynamic Fa3/5 -
1 0000.0001.1001 SecureDynamic Fa3/5 -
1 0000.0001.1100 SecureDynamic Fa3/6 -
1 0000.0001.1101 SecureDynamic Fa3/6 -
1 0000.0001.1200 SecureSticky Fa3/7 -
1 0000.0001.1201 SecureSticky Fa3/7 -
1 0000.0001.1300 SecureSticky Fa3/8 -
1 0000.0001.1301 SecureSticky Fa3/8 -
1 0000.0001.2000 SecureSticky Po2 -

```

```

-----
Total Addresses in System (excluding one mac per port) :8
Max Addresses limit in System (excluding one mac per port) :3072

```

### Example 4: Displaying a Maximum Number of MAC Addresses on an Interface

This example shows how to display the maximum allowed number of secure MAC addresses and the current number of secure MAC addresses on Gigabit Ethernet interface 1/1:

```

Switch# show port-security interface g1/1 vlan
Default maximum: 22
VLAN Maximum Current
2 22 3
3 22 3
4 22 3
5 22 1
6 22 2

```

### Example 5: Displaying Security Settings on an Interface for a VLAN Range

This example shows how to display the port security settings on Gigabit Ethernet interface 1/1 for VLANs 2 and 3:

```

Switch# show port-security interface g1/1 vlan 2-3
Default maximum: 22
VLAN Maximum Current
2 22 3
3 22 3

```

### Example 6: Displaying Secured MAC Addresses and Aging Information on an Interface

This example shows how to display all secure MAC addresses configured on Gigabit Ethernet interface 1/1 with aging information for each address.

```

Switch# show port-security interface g1/1 address

```

```

Secure Mac Address Table
-----
Vlan Mac Address Type Ports Remaining Age(mins)
----
2 0001.0001.0001 SecureConfigured Gi1/1 -
2 0001.0001.0002 SecureSticky Gi1/1 -
2 0001.0001.0003 SecureSticky Gi1/1 -
3 0001.0001.0001 SecureConfigured Gi1/1 -
3 0001.0001.0002 SecureSticky Gi1/1 -
3 0001.0001.0003 SecureSticky Gi1/1 -
4 0001.0001.0001 SecureConfigured Gi1/1 -
4 0001.0001.0002 SecureSticky Gi1/1 -

```

```

4    0001.0001.0003    SecureSticky          Gi1/1    -
5    0001.0001.0001    SecureConfigured     Gi1/1    -
6    0001.0001.0001    SecureConfigured     Gi1/1    -
6    0001.0001.0002    SecureConfigured     Gi1/1    -
-----
Total Addresses: 12

```

## Example 7: Displaying Secured MAC Addresses for a VLAN Range on an Interface

This example shows how to display all secure MAC addresses configured on VLANs 2 and 3 on Gigabit Ethernet interface 1/1 with aging information for each address:

```

Switch# show port-security interface g1/1 address vlan 2-3

          Secure Mac Address Table
-----
Vlan    Mac Address          Type                Ports    Remaining Age (mins)
-----
2       0001.0001.0001      SecureConfigured    Gi1/1    -
2       0001.0001.0002      SecureSticky        Gi1/1    -
2       0001.0001.0003      SecureSticky        Gi1/1    -
3       0001.0001.0001      SecureConfigured    Gi1/1    -
3       0001.0001.0002      SecureSticky        Gi1/1    -
3       0001.0001.0003      SecureSticky        Gi1/1    -
-----
Total Addresses: 12
Switch#

```

## Configuring Port Security with Other Features/Environments

The following topics are discussed:

- [DHCP and IP Source Guard, page 38-30](#)
- [802.1X Authentication, page 38-31](#)
- [Configuring Port Security in a Wireless Environment, page 38-31](#)
- [Configuring Port Security over Layer 2 EtherChannel, page 38-32](#)

## DHCP and IP Source Guard

You might want to configure port security with DHCP and IP Source Guard to prevent IP spoofing by unsecured MAC addresses. IP Source Guard supports two levels of IP traffic filtering:

- Source IP address filtering
- Source IP and MAC address filtering

When used in source IP and MAC address filtering, IP Source Guard uses private ACLs to filter traffic based on the source IP address, and uses port security to filter traffic based on the source MAC address. So, port security must be enabled on the access port in this mode.

When both features are enabled, the following limitations apply:

- The DHCP packet is not subject to port security dynamic learning.
- If multiple IP clients are connected to a single access port, port security cannot enforce exact binding of source IP and MAC address for each client.

Let's say that clients reside on an access port with the following IP/MAC address:

- client1: MAC1 <---> IP1
- client2: MAC2 <---> IP2

Then, any combination of the source MAC and IP address traffic is allowed:

- MAC1 <---> IP1, valid
- MAC2 <---> IP2, valid
- MAC1 <---> IP2, invalid
- MAC2 <---> IP1, invalid

IP traffic with the correct source IP and MAC address binding will be permitted and port security will dynamically learn its MAC address. IP traffic with source addresses that are not in the binding will be treated as invalid packets and dropped by port security. To prevent a denial of service attack, you must configure port security rate limiting for the invalid source MAC address.

## 802.1X Authentication

You might want to configure port security with 802.1X authentication to prevent MAC spoofing. 802.1X is not supported on regular or private VLAN trunks. On access ports and PVLAN host or promiscuous ports, both port security and 802.1X can be configured simultaneously. When both are configured, hosts must be 802.1X authenticated before port security can secure the MAC address of the host. Both 802.1X and port security must approve of the host or a security violation will be triggered. The type of security violation will depend on which feature rejects the port: if the host is allowed by 802.1X (for example, because the port is in multi-host mode) but is disallowed by port security, the port-security violation action will be triggered. If the host is allowed by port security but rejected by 802.1X (for example, because the host is non-authorized on a single-host mode port) then the 802.1X security violation action will be triggered.

**Note**

---

802.1X, port-security and VVID can all be configured on the same port.

---

For more information on the interaction between 802.1X and Port Security, see “Using 802.1X with Port Security” on page 15.

## Configuring Port Security in a Wireless Environment

If access points are connected to a secure port, do not configure a static MAC address for your users. A MAC address might move from one access point to another and might cause security violations if both the access points are connected on the same switch.

Figure 38-3 illustrates a typical topology of port security in a wireless environment.

Figure 38-3 Port Security in a Wireless Environment

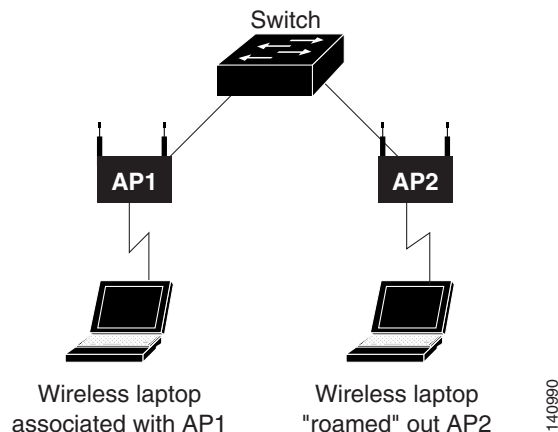

## Configuring Port Security over Layer 2 EtherChannel



### Note

Supervisor Engine 6-E does not support this feature.

Port security can be enabled on an EtherChannel in either trunk or access mode. (Refer to the “[Port Security on Access Ports](#)” section on page 38-6 and the “[Port Security on Trunk Ports](#)” section on page 38-16 for configuration steps.) When you do this in trunking mode, the MAC address restrictions apply to the entire port-channel on a per VLAN basis.

In general, be aware of the following:

- Port security on Layer 2 EtherChannel works only on access mode or trunk mode and is independent of the configuration on any physical member ports.
- If at least one member port is secured, port security cannot be disabled on the channel interface; it is rejected by the CLI.
- A secure port cannot join a non-secure EtherChannel; it is rejected by the CLI.
- Port security over EtherChannel is supported in both PAgP and LACP modes. It does not apply to Layer 3 EtherChannels.

## Port Security Guidelines and Restrictions

Follow these guidelines when configuring port security:

- A secure port cannot be a destination port for the Switch Port Analyzer (SPAN).
- A secure port and a static MAC address configuration for an interface are mutually exclusive.
- When you enter a maximum secure address value for an interface, and the new value is greater than the previous value, the new value overwrites the previously configured value. If the new value is less than the previous value and the number of configured secure addresses on the interface exceeds the new value, the command is rejected.

- While configuring trunk port security on a trunk port, you do not need to account for the protocol packets (like CDP and BPDU) because they are not learned and secured.
- You cannot enable port security aging on sticky secure MAC addresses.
- To restrict MAC spoofing using port security, you must enable 802.1X authentication.
- You cannot configure port security on dynamic ports. You must change the mode to access before you enable port security.
- When port security is enabled on an EtherChannel, 802.1X cannot be enabled.
- A secure EtherChannel does not work in PVLAN mode.

