



Configuring Network Security with ACLs

This chapter describes how to use access control lists (ACLs) to configure network security on the Catalyst 4500 series switch.



Note

For complete syntax and usage information for the commands used in this chapter, refer to the *Catalyst 4500 Series Switch Cisco IOS Command Reference* and related information at <http://www.cisco.com/univercd/cc/td/doc/product/software/ios121/121cgcr/index.htm>.

This chapter consists of the following major sections:

- [Understanding ACLs, page 24-1](#)
- [Hardware and Software ACL Support, page 24-4](#)
- [Layer 4 Operators in ACLs, page 24-5](#)
- [Configuring Unicast MAC Address Filtering, page 24-8](#)
- [Configuring Named MAC Extended ACLs, page 24-8](#)
- [Configuring VLAN Maps, page 24-9](#)
- [Using VLAN Maps with Router ACLs, page 24-15](#)
- [Displaying ACL Information, page 24-17](#)

Understanding ACLs

This section contains the following subsections:

- [ACL Overview, page 24-1](#)
- [Supported Features That Use ACLs, page 24-2](#)
- [Router ACLs, page 24-2](#)
- [VLAN Maps, page 24-3](#)

ACL Overview

An ACL is a collection of sequential permit and deny conditions that applies to packets. When a packet is received on an interface, the switch compares the fields in the packet against any applied ACLs to verify that the packet has the permissions required to be forwarded, based on the conditions specified in

the access lists. It tests the packets against the conditions in an access list one-by-one. The first match determines whether the switch accepts or rejects the packets. Because the switch stops testing conditions after the first match, the order of conditions in the list is critical. If no conditions match, the switch drops the packet. If there are no restrictions, the switch forwards the packet; otherwise, the switch drops the packet.

Switches traditionally operate at Layer 2, switching traffic within a VLAN, whereas routers route traffic between VLANs at Layer 3. The Catalyst 4500 series switch can accelerate packet routing between VLANs by using Layer 3 switching. The Layer 3 switch bridges the packet, and then routes the packet internally without going to an external router. The packet is then bridged again and sent to its destination. During this process, the switch can control all packets, including packets bridged within a VLAN.

You configure access lists on a router or switch to filter traffic and provide basic security for your network. If you do not configure ACLs, all packets passing through the switch could be allowed on all parts of the network. You can use ACLs to control which hosts can access different parts of a network or to decide which types of traffic are forwarded or blocked at router interfaces. For example, you can allow e-mail traffic to be forwarded but not Telnet traffic. ACLs can be configured to block inbound traffic, outbound traffic, or both. However, on Layer 2 interfaces, you can apply ACLs only in the inbound direction.

An ACL contains an ordered list of access control entries (ACEs). Each ACE specifies permit or deny and a set of conditions the packet must satisfy in order to match the ACE. The meaning of permit or deny depends on the context in which the ACL is used.

The Catalyst 4500 series switch supports two types of ACLs:

- IP ACLs, which filter IP traffic, including TCP, the User Datagram Protocol (UDP), Internet Group Management Protocol (IGMP), and Internet Control Message Protocol (ICMP).
- MAC (Ethernet) ACLs, which filter non-IP traffic.

Supported Features That Use ACLs

The switch supports two applications of ACLs to filter traffic:

- Router ACLs are applied to Layer 3 interfaces. They control the access of routed traffic between VLANs. All Catalyst 4500 series switches can create router ACLs, but you must have a Cisco IOS software image on your switch to apply an ACL to a Layer 3 interface and filter packets routed between VLANs.
- VLAN ACLs or VLAN maps control the access of all packets (bridged and routed). You can use VLAN maps to filter traffic between devices in the same VLAN. You do not need the enhanced image to create or apply VLAN maps. VLAN maps are configured to control access based on Layer 3 addresses for IP. MAC addresses using Ethernet ACEs control the access of unsupported protocols. After you apply a VLAN map to a VLAN, all packets (routed or bridged) entering the VLAN are checked against that map. Packets can either enter the VLAN through a switch port or through a routed port after being routed.

You can use both router ACLs and VLAN maps on the same switch.

Router ACLs

You can apply router ACLs on switch virtual interfaces (SVIs), which are Layer 3 interfaces to VLANs; on physical Layer 3 interfaces; and on Layer 3 EtherChannel interfaces. Router ACLs are applied on interfaces for specific directions (inbound or outbound). You can apply one IP access list in each direction.

Multiple features can use one ACL for a given interface, and one feature can use multiple ACLs. When a single router ACL is used by multiple features, it is examined multiple times. The access list type determines the input to the matching operation:

- Standard IP access lists use source addresses for matching operations.
- Extended IP access lists use source and destination addresses and optional protocol type information for matching operations.

The switch examines ACLs associated with features configured on a given interface and a direction. As packets enter the switch on an interface, ACLs associated with all inbound features configured on that interface are examined. After packets are routed and before they are forwarded to the next hop, all ACLs associated with outbound features configured on the egress interface are examined.

ACLs permit or deny packet forwarding based on how the packet matches the entries in the ACL. For example, you can use access lists to allow one host to access a part of a network, but prevent another host from accessing the same part. In [Figure 24-1](#), ACLs applied at the router input allow Host A to access the Human Resources network, but prevent Host B from accessing the same network.

Figure 24-1 Using ACLs to Control Traffic to a Network

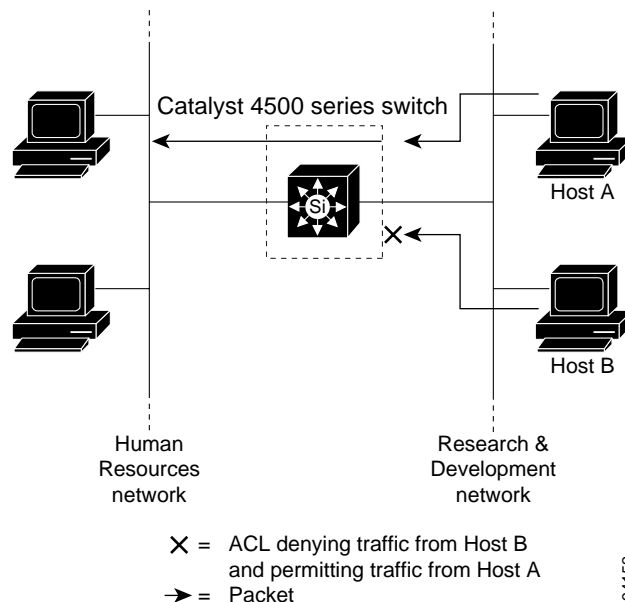

VLAN Maps

VLAN maps can control the access of all traffic in a VLAN. You can apply VLAN maps on the switch to all packets that are routed into or out of a VLAN or are bridged within a VLAN. Unlike router ACLs, VLAN maps are not defined by direction (input or output).

You can configure VLAN maps to match Layer 3 addresses for IP traffic. Access of all non-IP protocols is controlled with a MAC address and an Ethertype using MAC ACLs in VLAN maps. (IP traffic is not controlled by MAC ACLs in VLAN maps.) You can enforce VLAN maps only on packets going through the switch; you cannot enforce VLAN maps on traffic between hosts on a hub or on another switch connected to this switch.

With VLAN maps, forwarding packets is permitted or denied, based on the action specified in the map. Figure 24-2 illustrates how a VLAN map is applied to deny a specific type of traffic from Host A in VLAN 10 from being forwarded.

Figure 24-2 Using VLAN Maps to Control Traffic

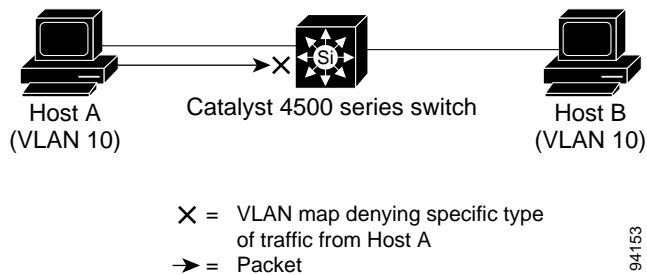

Hardware and Software ACL Support

This section describes how to determine whether ACLs are processed in hardware or in software:

- Flows that match a deny statement in standard and extended ACLs (input only) are dropped in hardware if ICMP unreachable messages are disabled.
- Flows that match a permit statement in standard and extended ACLs (input and output) are processed in hardware.
- The following ACL types are not supported in software:
 - Standard Xerox Network Systems (XNS) Protocol access list
 - Extended XNS access list
 - DECnet access list
 - Protocol type-code access list
 - Standard Internet Packet Exchange (IPX) access list
 - Extended IPX access list



Note

Packets that require logging are processed in software. A copy of the packets is sent to the CPU for logging while the actual packets are forwarded in hardware so that non-logged packet processing is not impacted.

By default, the Catalyst 4500 Series sends ICMP unreachable messages when a packet is denied by an access list; these packets are not dropped in hardware but are forwarded to the switch so that it can generate the ICMP unreachable message.

To drop access-list denied packets in hardware on the input interface, you must disable ICMP unreachable messages using the **no ip unreachable** interface configuration command. The **ip unreachable** command is enabled by default.

Packets denied by an output access list are always forwarded to the CPU.

Layer 4 Operators in ACLs

The following sections describe guidelines and restrictions for configuring ACLs that include Layer 4 port operations:

- [Restrictions for Layer 4 Operations, page 24-5](#)
- [Configuration Guidelines for Layer 4 Operations, page 24-5](#)
- [How ACL Processing Impacts CPU, page 24-6](#)

Restrictions for Layer 4 Operations

You can specify these operator types, each of which uses one Layer 4 operation in the hardware:

- gt (greater than)
- lt (less than)
- neq (not equal)
- range (inclusive range)

We recommend that you not specify more than six different operations on the same ACL. If you exceed this number, each new operation might cause the affected ACE (access control entry) to be translated into multiple ACEs in hardware. If you exceed this number, the affected ACE might be processed in software.

Configuration Guidelines for Layer 4 Operations

Keep the following guidelines in mind when using Layer 4 operators:

- Layer 4 operations are considered different if the operator or operand differ. For example, the following ACL contains three different Layer 4 operations because gt 10 and gt 11 are considered two different Layer 4 operations:

```
... gt 10 permit
... lt 9 deny
... gt 11 deny
```



Note

The eq operator can be used an unlimited number of times because eq does not use a Layer 4 operation in hardware.

- Layer 4 operations are considered different if the same operator/operand couple applies once to a source port and once to a destination port, as in the following example:

```
... Src gt 10...
... Dst gt 10
```

A more detailed example follows:

```
access-list 101
... (dst port) gt 10 permit
... (dst port) lt 9 deny
... (dst port) gt 11 deny
... (dst port) neq 6 permit
... (src port) neq 6 deny
... (dst port) gt 10 deny
```

```

access-list 102
... (dst port) gt 20 deny
... (src port) lt 9 deny
... (src port) range 11 13 deny
... (dst port) neq 6 permit

```

Access lists 101 and 102 use the following Layer 4 operations:

- Access list 101 Layer 4 operations: 5
 - gt 10 permit and gt 10 deny both use the same operation because they are identical and both operate on the destination port.
- Access list 102 Layer 4 operations: 4
- Total Layer 4 operations: 8 (due to sharing between the two access lists)
 - neg6 permit is shared between the two ACLs because they are identical and both operate on the same destination port.
- A description of the Layer 4 operations usage is as follows:
 - Layer 4 operation 1 stores gt 10 permit and gt 10 deny from ACL 101
 - Layer 4 operation 2 stores lt 9 deny from ACL 101
 - Layer 4 operation 3 stores gt 11 deny from ACL 101
 - Layer 4 operation 4 stores neg 6 permit from ACL 101 and 102
 - Layer 4 operation 5 stores neg 6 deny from ACL 101
 - Layer 4 operation 6 stores gt 20 deny from ACL 102
 - Layer 4 operation 7 stores lt 9 deny from ACL 102
 - Layer 4 operation 8 stores range 11 13 deny from ACL 102

How ACL Processing Impacts CPU

ACL processing can impact the CPU in two ways:

- For some packets, when the hardware runs out of resources, the software must perform the ACL matches:
 - TCP flag combinations other than rst ack and syn fin rst are processed in software. rst ack is equivalent to the keyword **established**.
 - You can specify up to six Layer 4 operations (lt, gt, neq, and range) in an ACL in order for all operations to be guaranteed to be processed in hardware. More than six Layer 4 operations will trigger an attempt to translate the excess operations into multiple ACEs in hardware. If this attempt fails, packets will be processed in software. The translation process is less likely to succeed on large ACLs with a great number of Layer 4 operations, and on switches with large numbers of ACLs configured. The precise limit depends on how many other ACLs are configured and which specific Layer 4 operations are used by the ACLs being translated. The eq operator does not require any Layer 4 operations and can be used any number of times.
 - If the total number of Layer 4 operations in an ACL is less than six, you can distribute the operations in any way you choose.

Examples:

The following access lists will be processed completely in hardware:

```
access-list 104 permit tcp any any established
access-list 105 permit tcp any any rst ack
access-list 107 permit tcp any synfin rst
```

Access lists 104 and 105 are identical; established is shorthand for rst and ack.

Access list 101, below, will be processed completely in software:

```
access-list 101 permit tcp any any urg
```

Because four source and two destination operations exist, access list 106, below, will be processed in hardware:

```
access-list 106 permit tcp any range 100 120 any range 120 140
access-list 106 permit tcp any range 140 160 any range 180 200
access-list 106 permit tcp any range 200 220
access-list 106 deny tcp any range 220 240
```

In the following code, the Layer 4 operations for the third ACE will trigger an attempt to translate dst lt 1023 into multiple ACEs in hardware, because three source and three destination operations exist. If the translation attempt fails, the third ACE will be processed in software.

```
access-list 102 permit tcp any lt 80 any gt 100
access-list 102 permit tcp any range 100 120 any range 120 1024
access-list 102 permit tcp any gt 1024 any lt 1023
```

Similarly, for access list 103, below, the third ACE will trigger an attempt to translate dst gt 1023 into multiple ACEs in hardware. If the attempt fails, the third ACE will be processed in software. Although the operations for source and destination ports look similar, they are considered different Layer 4 operations.)

```
access-list 103 permit tcp any lt 80 any lt 80
access-list 103 permit tcp any range 100 120 any range 100 120
access-list 103 permit tcp any gt 1024 any gt 1023
```



Note Remember that source port lt 80 and destination port lt 80 are considered different operations.

- Some packets must be sent to the CPU for accounting purposes, but the action is still performed by the hardware. For example, if a packet must be logged, a copy is sent to the CPU for logging, but the forwarding (or dropping) is performed in the hardware. Although logging slows the CPU, it does not affect the forwarding rate. This sequence of events would happen under the following conditions:
 - When a log keyword is used
 - When an output ACL denies a packet
 - When an input ACL denies a packet, and on the interface where the ACL is applied, **ip unreachable** is enabled (**ip unreachable** is enabled by default on all the interfaces)

Configuring Unicast MAC Address Filtering

To block all unicast traffic to or from a MAC address in a specified VLAN, perform this task:

Command	Purpose
Router(config)# mac-address-table static mac_address vlan vlan_ID drop	Blocks all traffic to or from the configured unicast MAC address in the specified VLAN. To clear MAC address-based blocking, use the no form of this command without the drop keyword.

This example shows how to block all unicast traffic to or from MAC address 0050.3e8d.6400 in VLAN 12:

```
Router# configure terminal
Router(config)# mac-address-table static 0050.3e8d.6400 vlan 12 drop
```

Configuring Named MAC Extended ACLs

You can filter non-IP traffic on a VLAN and on a physical Layer 2 port by using MAC addresses and named MAC extended ACLs. The procedure is similar to that of configuring other extended named ACLs. You can use a number to name the access list, but MAC access list numbers from 700 to 799 are not supported.



Note

Named MAC extended ACLs cannot be applied to Layer 3 interfaces.

For more information about the supported non-IP protocols in the **mac access-list extended** command, refer to the Catalyst 4500 Series Switch Cisco IOS Command Reference.

To create a named MAC extended ACL, perform this task:

	Command	Purpose
Step 1	Switch# configure terminal	Enters global configuration mode.
Step 2	Switch(config)# mac access-list extended name	Defines an extended MAC access list using a name.
Step 3	Switch(config-ext-macl)# {deny permit} {any host source MAC address / source MAC address mask} {any host destination MAC address / destination MAC address mask} [protocol-family {appletalk arp-non-ipv4 decnet ipx ipv6 rarp-ipv4 rarp-non-ipv4 vines xns }]	In extended MAC access-list configuration mode, specify to permit or deny any source MAC address, a source MAC address with a mask, or a specific host source MAC address and any destination MAC address, destination MAC address with a mask, or a specific destination MAC address. (Optional) • [protocol-family {appletalk arp-non-ipv4 decnet ipx ipv6 rarp-ipv4 rarp-non-ipv4 vines xns }]
Step 4	Switch(config-ext-macl)# end	Returns to privileged EXEC mode.
Step 5	Switch# show access-lists [number name]	Shows the access list configuration.
Step 6	Switch(config)# copy running-config startup-config	(Optional) Save your entries in the configuration file.

You can use the **no mac access-list extended** *name* global configuration command to delete the entire ACL. You can also delete individual ACEs from named MAC extended ACLs.

This example shows how to create and display an access list named `mac1`, denying only EtherType DECnet Phase IV traffic, but permitting all other types of traffic.

```
Switch(config)# mac access-list extended mac1
Switch(config-ext-macl)# deny any any decnet-iv (old) protocol-family decnet (new)
Switch(config-ext-macl)# permit any any
Switch(config-ext-macl)# end
Switch # show access-lists
Extended MAC access list mac1
    deny any any decnet-iv (old) protocol-family decnet (new)
    permit any any
```

Configuring VLAN Maps

This section describes how to configure VLAN maps, which is the only way to control filtering within a VLAN. VLAN maps have no direction. To filter traffic in a specific direction by using a VLAN map, you need to include an ACL with specific source or destination addresses. If there is a match clause for that type of packet (IP or MAC) in the VLAN map, the default action is to drop the packet if the packet does not match any of the entries within the map. If there is no match clause for that type of packet, the default is to forward the packet.

To create a VLAN map and apply it to one or more VLANs, perform this task

-
- Step 1** Create the standard or extended IP ACLs or named MAC extended ACLs that you want to apply to the VLAN.
- Step 2** Enter the **vlan access-map** global configuration command to create a VLAN ACL map entry.
- Step 3** In access map configuration mode, you have the optional to enter an **action** (**forward** [the default] or **drop**) and enter the **match** command to specify an IP packet or a non-IP packet and to match the packet against one or more ACLs (standard or extended). If a match clause is not specified, the action is applied to all packets. The match clause can be used to match against multiple ACLs. If a packet matches any of the specified ACLs, the action is applied.



Note If the VLAN map has a match clause for the type of packet (IP or MAC) and the packet does not match the type, the default is to drop the packet. If there is no match clause in the VLAN map for that type of packet, and no action specified, the packet is forwarded.

- Step 4** Use the **vlan filter** global configuration command to apply a VLAN map to one or more VLANs.
-

VLAN Map Configuration Guidelines

Keep the following guidelines in mind when configuring VLAN maps:

- VLAN maps do not filter IPv4 ARP packets.
- If there is no router ACL configured to deny traffic on a routed VLAN interface (input or output), and no VLAN map configured, all traffic is permitted.

- Each VLAN map consists of a series of entries. The order of entries in a VLAN map is important. A packet that comes into the switch is tested against the first entry in the VLAN map. If it matches, the action specified for that part of the VLAN map is taken. If there is no match, the packet is tested against the next entry in the map.
- If the VLAN map has at least one match clause for the type of packet (IP or MAC) and the packet does not match any of these match clauses, the default is to drop the packet. If there is no match clause for that type of packet in the VLAN map, the default is to forward the packet.
- The system might take longer to boot if you have configured a very large number of ACLs.

Creating and Deleting VLAN Maps

Each VLAN map consists of an ordered series of entries. To create, add to, or delete a VLAN map entry, perform this task:

	Command	Purpose
Step 1	Switch# configure terminal	Enters global configuration mode.
Step 2	Switch(config)# vlan access-map <i>name [number]</i>	Creates a VLAN map, and give it a name and (optionally) a number. The number is the sequence number of the entry within the map. When you create VLAN maps with the same name, numbers are assigned sequentially in increments of 10. When modifying or deleting maps, you can enter the number of the map entry that you want to modify or delete. This command enables access-map configuration mode.
Step 3	Switch(config-access-map)# action { drop forward }	(Optional) Sets the action for the map entry. The default is to forward.
Step 4	Switch(config-access-map)# match { ip mac } address { <i>name</i> <i>number</i> } [<i>name</i> <i>number</i>]	Matches the packet (using either the IP or MAC address) against one or more standard or extended access lists. Note that packets are matched only against access lists of the correct protocol type. IP packets are compared with standard or extended IP access lists. Non-IP packets are only compared with named MAC extended access lists. If a match clause is not specified, the action is taken on all packets.
Step 5	Switch(config-access-map)# end	Returns to global configuration mode.
Step 6	Switch(config)# show running-config	Displays the access list configuration.
Step 7	Switch(config)# copy running-config startup-config	(Optional) Saves your entries in the configuration file.

You can use the **no vlan access-map** *name* global configuration command to delete a map. You can use the **no vlan access-map** *name number* global configuration command to delete a single sequence entry from within the map. You can use the **no action** access-map configuration command to enforce the default action, which is to forward.

VLAN maps do not use the specific **permit** or **deny** keywords. To deny a packet by using VLAN maps, create an ACL that would match the packet, and then set the action to drop. A permit in the ACL is the same as a match. A deny in the ACL means no match.

Examples of ACLs and VLAN Maps

These examples show how to create ACLs and VLAN maps that for specific purposes.

Example 1

This example shows how to create an ACL and a VLAN map to deny a packet. In the first map, any packets that match the ip1 ACL (TCP packets) would be dropped. You first create the ip1 ACL to permit any TCP packet and no other packets. Because there is a match clause for IP packets in the VLAN map, the default action is to drop any IP packet that does not match any of the match clauses.

```
Switch(config)# ip access-list extended ip1
Switch(config-ext-nacl)# permit tcp any any
Switch(config-ext-nacl)# exit
Switch(config)# vlan access-map map_1 10
Switch(config-access-map)# match ip address ip1
Switch(config-access-map)# action drop
```

This example shows how to create a VLAN map to permit a packet. ACL ip2 permits UDP packets; and any packets that match the ip2 ACL are forwarded.

```
Switch(config)# ip access-list extended ip2
Switch(config-ext-nacl)# permit udp any any
Switch(config-ext-nacl)# exit
Switch(config)# vlan access-map map_1 20
Switch(config-access-map)# match ip address ip2
Switch(config-access-map)# action forward
```

In this map, any IP packets that did not match any of the previous ACLs (that is, packets that are not TCP packets or UDP packets) would get dropped.

Example 2

In this example, the VLAN map is configured to drop IP packets and to forward MAC packets by default. By applying standard ACL 101 and the extended named access lists **igmp-match** and **tcp-match**, the VLAN map is configured to do the following:

- Forward all UDP packets
- Drop all IGMP packets
- Forward all TCP packets
- Drop all other IP packets
- Forward all non-IP packets

```
Switch(config)# access-list 101 permit udp any any
Switch(config)# ip access-list extended igmp-match
Switch(config-ext-nacl)# permit igmp any any
Switch(config)# ip access-list extended tcp-match
Switch(config-ext-nacl)# permit tcp any any
Switch(config-ext-nacl)# exit
Switch(config)# vlan access-map drop-ip-default 10
Switch(config-access-map)# match ip address 101
Switch(config-access-map)# action forward
Switch(config-access-map)# exit
Switch(config)# vlan access-map drop-ip-default 20
Switch(config-access-map)# match ip address igmp-match
Switch(config-access-map)# action drop
Switch(config-access-map)# exit
Switch(config)# vlan access-map drop-ip-default 30
Switch(config-access-map)# match ip address tcp-match
Switch(config-access-map)# action forward
```

Example 3

In this example, the VLAN map is configured to drop MAC packets and forward IP packets by default. By applying MAC extended access lists, **good-hosts** and **good-protocols**, the VLAN map is configured to do the following:

- Forward MAC packets from hosts 0000.0c00.0111 and 0000.0c00.0211
- Forward MAC packets of DECnet or VINES (Virtual Integrated Network Service) protocol-family
- Drop all other non-IP packets
- Forward all IP packets

```
Switch(config)# mac access-list extended good-hosts
Switch(config-ext-macl)# permit host 000.0c00.0111 any
Switch(config-ext-macl)# permit host 000.0c00.0211 any
Switch(config-ext-nacl)# exit
Switch(config)# mac access-list extended good-protocols
Switch(config-ext-macl)# permit any any protocol-family decnet
Switch(config-ext-macl)# permit any any protocol-family vines
Switch(config-ext-nacl)# exit
Switch(config)# vlan access-map drop-mac-default 10
Switch(config-access-map)# match mac address good-hosts
Switch(config-access-map)# action forward
Switch(config-access-map)# exit
Switch(config)# vlan access-map drop-mac-default 20
Switch(config-access-map)# match mac address good-protocols
Switch(config-access-map)# action forward
```

Example 4

In this example, the VLAN map is configured to drop all packets (IP and non-IP). By applying access lists **tcp-match** and **good-hosts**, the VLAN map is configured to do the following:

- Forward all TCP packets
- Forward MAC packets from hosts 0000.0c00.0111 and 0000.0c00.0211
- Drop all other IP packets
- Drop all other MAC packets

```
Switch(config)# vlan access-map drop-all-default 10
Switch(config-access-map)# match ip address tcp-match
Switch(config-access-map)# action forward
Switch(config-access-map)# exit
Switch(config)# vlan access-map drop-all-default 20
Switch(config-access-map)# match mac address good-hosts
Switch(config-access-map)# action forward
```

Applying a VLAN Map to a VLAN

To apply a VLAN map to one or more VLANs, perform this task:

	Command	Purpose
Step 1	Switch# configure terminal	Enters global configuration mode.
Step 2	Switch(config)# vlan filter <i>mapname vlan-list list</i>	Applies the VLAN map to one or more VLAN IDs. The list can be a single VLAN ID (22), a consecutive list (10-22), or a string of VLAN IDs (12, 22, 30). Spaces around comma, and dash, are optional.
Step 3	Switch(config)# show running-config	Displays the access list configuration.
Step 4	cSwitch(config)# copy running-config startup-config	(Optional) Saves your entries in the configuration file.

This example shows how to apply VLAN map 1 to VLANs 20 through 22:

```
Switch(config)# vlan filter map 1 vlan-list 20-22
```

Using VLAN Maps in Your Network

Figure 24-3 shows a typical wiring closet configuration. Host X and Host Y are in different VLANs, connected to wiring closet switches A and C. Traffic moving from Host X to Host Y is routed by Switch B. Access to traffic moving from Host X to Host Y can be controlled at the entry point of Switch A. In the following configuration, the switch can support a VLAN map and a QoS classification ACL.

Figure 24-3 Wiring Closet Configuration

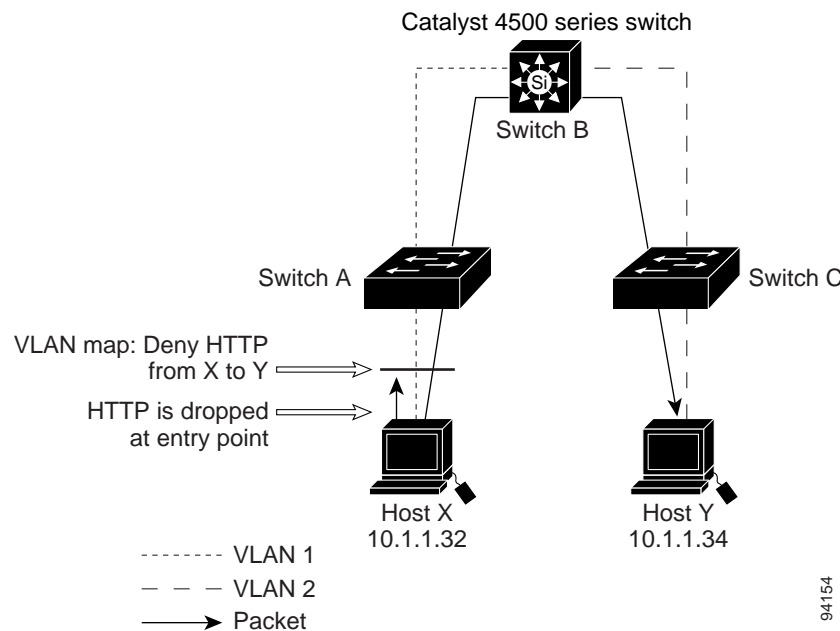

94154

For example, if you do not want HTTP traffic to be switched from Host X to Host Y, you could apply a VLAN map on Switch A to drop all HTTP traffic moving from Host X (IP address 10.1.1.32) to Host Y (IP address 10.1.1.34) at Switch A and not bridge the traffic to Switch B. To configure this scenario, you would do the following:

First, define an IP access list `http` to permit (match) any TCP traffic on the HTTP port, as follows:

```
Switch(config)# ip access-list extended http
Switch(config-ext-nacl)# permit tcp host 10.1.1.32 host 10.1.1.34 eq www
Switch(config-ext-nacl)# exit
```

Next, create a VLAN access map named `map2` so that traffic that matches the `http` access list is dropped and all other IP traffic is forwarded, as follows:

```
Switch(config)# vlan access-map map2 10
Switch(config-access-map)# match ip address http
Switch(config-access-map)# action drop
Switch(config-access-map)# exit
Switch(config)# ip access-list extended match_all
Switch(config-ext-nacl)# permit ip any any
Switch(config-ext-nacl)# exit
Switch(config)# vlan access-map map2 20
Switch(config-access-map)# match ip address match_all
Switch(config-access-map)# action forward
```

Then, apply the VLAN access map named `map2` to VLAN 1, as follows:

```
Switch(config)# vlan filter map2 vlan 1
```

Denying Access to a Server on Another VLAN

Figure 24-4 shows how to restrict access to a server on another VLAN. In this example, server 10.1.1.100 in VLAN 10 has the following access restrictions:

- Hosts in subnet 10.1.2.0/8 in VLAN 20 should not have access.
- Hosts 10.1.1.4 and 10.1.1.8 in VLAN 10 should not have access.

Figure 24-4 Deny Access to a Server on Another VLAN

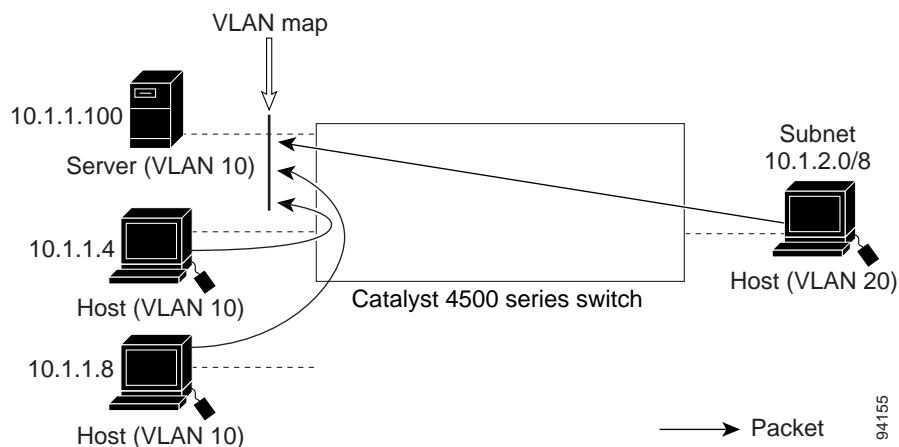

This procedure configures ACLs with VLAN maps to deny access to a server on another VLAN. The VLAN map `SERVER 1_ACL` denies access to hosts in subnet 10.1.2.0/8, host 10.1.1.4, and host 10.1.1.8. Then it permits all other IP traffic. In Step 3, VLAN map `SERVER1` is applied to VLAN 10.

To configure this scenario, you could take the following steps:

- Step 1** Define the IP ACL to match and permit the correct packets.

```
Switch(config)# ip access-list extended SERVER1_ACL
Switch(config-ext-nacl)# permit ip 10.1.2.0 0.0.0.255 host 10.1.1.100
Switch(config-ext-nacl)# permit ip host 10.1.1.4 host 10.1.1.100
Switch(config-ext-nacl)# permit ip host 10.1.1.8 host 10.1.1.100
Switch(config-ext-nacl)# exit
```

- Step 2** Define a VLAN map using the ACL to drop IP packets that match SERVER1_ACL and forward IP packets that do not match the ACL.

```
Switch(config)# vlan access-map SERVER1_MAP
Switch(config-access-map)# match ip address SERVER1_ACL
Switch(config-access-map)# action drop
Switch(config)# vlan access-map SERVER1_MAP 20
Switch(config-access-map)# action forward
Switch(config-access-map)# exit
```

- Step 3** Apply the VLAN map to VLAN 10.

```
Switch(config)# vlan filter SERVER1_MAP vlan-list 10.
```

Using VLAN Maps with Router ACLs

If the VLAN map has a match clause for a packet type (IP or MAC) and the packet does not match the type, the default is to drop the packet. If there is no match clause in the VLAN map, and no action is specified, the packet is forwarded if it does not match any VLAN map entry.

Guidelines for Using Router ACLs and VLAN Maps

Use these guidelines when you need to use a router ACL and a VLAN map on the same VLAN.

Because the switch hardware performs one lookup for each direction (input and output), you must merge a router ACL and a VLAN map when they are configured on the same VLAN. Merging the router ACL with the VLAN map can significantly increase the number of ACEs.

When possible, try to write the ACL so that all entries have a single action except for the final, default action. You should write the ACL using one of these two forms:

```
permit...
permit...
permit...
deny ip any any
```

or

```
deny...
deny...
deny...
permit ip any any
```

To define multiple permit or deny actions in an ACL, group each action type together to reduce the number of entries.

If you need to specify the full-flow mode and the ACL contains both IP ACEs and TCP/UDP/ICMP ACEs with Layer 4 information, put the Layer 4 ACEs at the end of the list. Doing this gives priority to the filtering of traffic based on IP addresses.

Examples of Router ACLs and VLAN Maps Applied to VLANs

These examples show how router ACLs and VLAN maps are applied on a VLAN to control the access of switched, bridged, routed, and multicast packets. Although the following illustrations show packets being forwarded to their destination, each time a packet crosses a line indicating a VLAN map or an ACL, the packet could be dropped rather than forwarded.

ACLs and Switched Packets

Figure 24-5 shows how an ACL processes packets that are switched within a VLAN. Packets switched within the VLAN are not processed by router ACLs.

Figure 24-5 Applying ACLs on Switched Packets

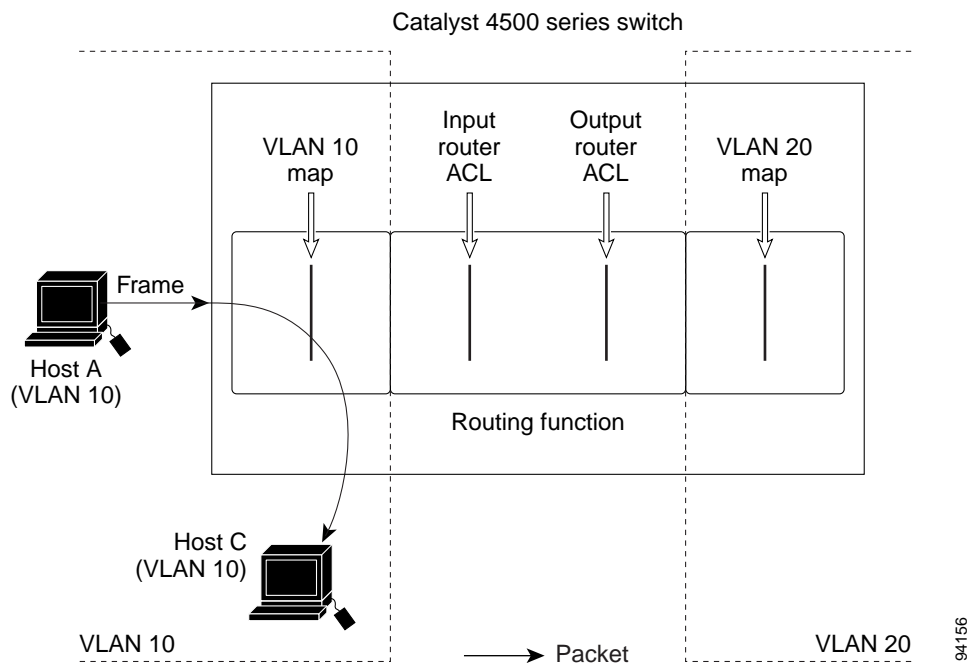

ACLs and Routed Packets

Figure 24-6 shows how ACLs are applied on routed packets. For routed packets, the ACLs are applied in this order:

1. VLAN map for input VLAN
2. Input router ACL
3. Output router ACL
4. VLAN map for output VLAN

Figure 24-6 Applying ACLs on Routed Packets

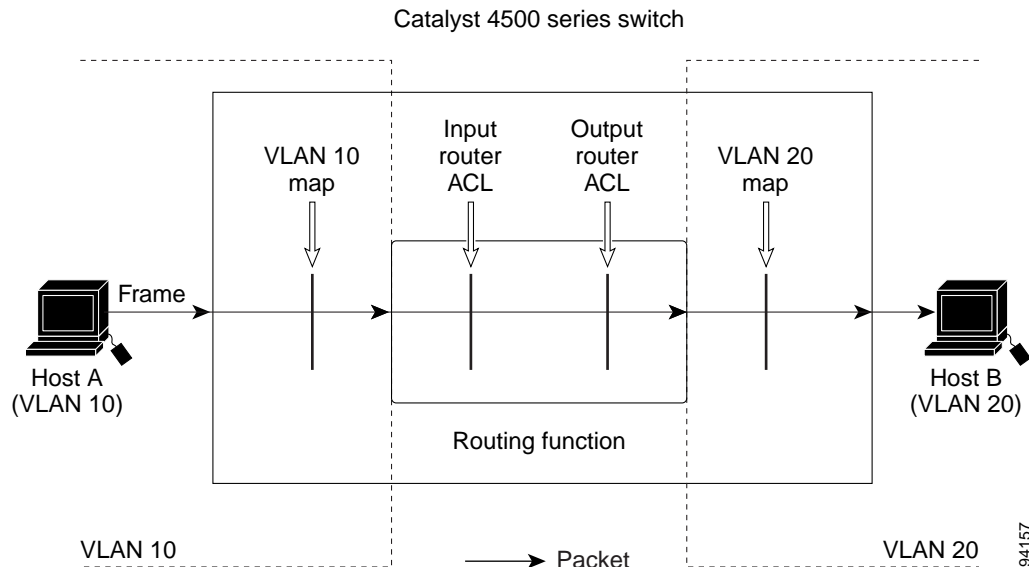

Displaying ACL Information

To display information about VLAN access maps or VLAN filters, perform one of these tasks:

Command	Purpose
Switch# <code>show vlan access-map [mapname]</code>	Show information about all VLAN access-maps or the specified access map.
Switch# <code>show vlan filter [access-map name / vlan vlan-id]</code>	Show information about all VLAN filters or about a specified VLAN or VLAN access map.

This is an example of the `show vlan access-map` command:

```
Switch# show vlan access-map
Vlan access-map "map_1" 10
  Match clauses:
    ip address: ip1
  Action:
    drop
Vlan access-map "map_1" 20
  Match clauses:
    mac address: mac1
  Action:
    forward
Vlan access-map "map_1" 30
  Match clauses:
  Action:
    drop
```



Note

Sequence 30 does not have a match clause. All packets (IP as well as non-IP) will be matched against it and dropped.

This is an example of the **show vlan filter** command:

```
Switch# show vlan filter
VLAN Map map_1 is filtering VLANs:
 20-22
```