



## Understanding and Configuring UDLD

---

This chapter describes how to configure the UniDirectional Link Detection (UDLD) on the Catalyst 4000 family switch. It also provides guidelines, procedures, and configuration examples.

This chapter includes the following major sections:

- [Overview of UDLD, page 16-1](#)
- [Default UDLD Configuration, page 16-2](#)
- [Configuring UDLD, page 16-2](#)



**Note**

For complete syntax and usage information for the commands used in this chapter, refer to the *Cisco IOS Command Reference for the Catalyst 4000 Family Switch* and the publications at: <http://www.cisco.com/univercd/cc/td/doc/product/software/ios121/121cgcr/index.htm>

---

### Overview of UDLD

UDLD allows devices connected through fiber-optic or copper Ethernet cables (for example, Category 5 cabling) to monitor the physical configuration of the cables and detect when a unidirectional link exists. A unidirectional link occurs whenever traffic transmitted by the local device over a link is received by the neighbor but traffic transmitted from the neighbor is not received by the local device. When a unidirectional link is detected, UDLD shuts down the affected interface and alerts the user. Unidirectional links can cause a variety of problems, including spanning tree topology loops.

UDLD is a Layer 2 protocol that works with the Layer 1 mechanisms to determine the physical status of a link. At Layer 1, autonegotiation takes care of physical signaling and fault detection. UDLD performs tasks that autonegotiation cannot perform, such as detecting the identities of neighbors and shutting down misconnected interfaces. When you enable both autonegotiation and UDLD, Layer 1 and Layer 2 detections work together to prevent physical and logical unidirectional connections and the malfunctioning of other protocols.

If one of the fiber strands in a pair is disconnected, as long as autonegotiation is active, the link does not stay up. In this case, the logical link is undetermined, and UDLD does not take any action. If both fibers are working normally from a Layer 1 perspective, then UDLD at Layer 2 determines whether those fibers are connected correctly and whether traffic is flowing bidirectionally between the right neighbors. This check cannot be performed by autonegotiation, because autonegotiation operates at Layer 1.

The switch periodically transmits UDLD packets to neighbor devices on interfaces with UDLD enabled. If the packets are echoed back within a specific time frame and they are lacking a specific acknowledgment (echo), the link is flagged as unidirectional and the interface is shut down. Devices on both ends of the link must support UDLD in order for the protocol to successfully identify and disable unidirectional links.



**Note**

By default, UDLD is locally disabled on copper interfaces to avoid sending unnecessary control traffic on this type of media, since it is often used for access interfaces.

Figure 16-1 shows an example of a unidirectional link condition. Switch B successfully receives traffic from Switch A on the interface. However, Switch A does not receive traffic from Switch B on the same interface. UDLD detects the problem and disables the interface.

**Figure 16-1 Unidirectional Link**

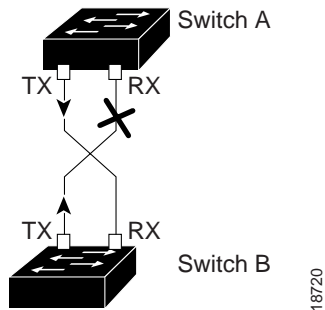

## Default UDLD Configuration

Table 16-1 shows the UDLD default configuration.

**Table 16-1 UDLD Default Configuration**

Feature	Default Status
UDLD global enable state	Globally disabled
UDLD per-interface enable state for fiber-optic media	Enabled on all Ethernet fiber-optic interfaces
UDLD per-interface enable state for twisted-pair (copper) media	Disabled on all Ethernet 10/100 and 1000BaseTX interfaces

## Configuring UDLD

The following sections describe how to configure UDLD:

- [Enabling UDLD Globally, page 16-3](#)
- [Enabling UDLD on Individual Interfaces, page 16-3](#)
- [Disabling UDLD on Nonfiber-Optic Interfaces, page 16-3](#)
- [Disabling UDLD on Fiber-Optic Interfaces, page 16-4](#)
- [Resetting Disabled Interfaces, page 16-4](#)

## Enabling UDLD Globally

To enable UDLD globally on all fiber-optic interfaces on the switch, enter the following command:

Command	Purpose
Switch(config)# <b>[no] udld enable</b>	<p>Enables UDLD globally on fiber-optic interfaces on the switch.</p> <p>Use the <b>no</b> keyword to globally disable UDLD on fiber-optic interfaces.</p> <p><b>Note</b> This command configures only fiber-optic interfaces. An individual interface configuration overrides the setting of this command.</p>

## Enabling UDLD on Individual Interfaces

To enable UDLD on individual interfaces, perform this procedure:

	Task	Command
Step 1	Enable UDLD on a specific interface. On a fiber-optic interface, this command overrides the <b>udld enable</b> global configuration command setting.	Switch(config-if)# <b>udld enable</b>
Step 2	Verify the configuration.	Switch# <b>show udld interface</b>

## Disabling UDLD on Nonfiber-Optic Interfaces

To disable UDLD on individual nonfiber-optic interfaces, perform this procedure:

	Task	Command
Step 1	<p>Disable UDLD on a nonfiber-optic interface.</p> <p><b>Note</b> On fiber-optic interfaces, the <b>no udld enable</b> command reverts the interface configuration to the <b>udld enable</b> global configuration command setting.</p>	Switch(config-if)# <b>no udld enable</b>
Step 2	Verify the configuration.	Switch# <b>show udld interface</b>

## Disabling UDLD on Fiber-Optic Interfaces

To disable UDLD on individual fiber-optic interfaces, perform this procedure:

	Task	Command
Step 1	Disable UDLD on a fiber-optic interface.  <b>Note</b> This command is not supported on nonfiber-optic interfaces.  Use the <b>no</b> keyword to revert to the <b>udld enable</b> global configuration command setting.	<pre>Switch(config-if)# <b>udld disable</b></pre>
Step 2	Verify the configuration.	<pre>Switch# <b>show udld interface</b></pre>

## Resetting Disabled Interfaces

To reset all interfaces that have been shut down by UDLD, enter the following command:

Command	Purpose
<pre>Switch# <b>udld reset</b></pre>	Resets all interfaces that have been shut down by UDLD.