



Configuring Spanning Tree PortFast, BPDU Guard, BPDU Filter, UplinkFast, BackboneFast, and Loop Guard

This chapter describes how to configure the PortFast, BPDU guard, BPDU filter, UplinkFast, BackboneFast, and loop guard spanning tree enhancements on the Catalyst enterprise LAN switches.



Note

For information on configuring spanning tree, see [Chapter 7, “Configuring Spanning Tree.”](#)



Note

For complete syntax and usage information for the commands used in this chapter, refer to the *Catalyst 4500 Series, Catalyst 2948G, and Catalyst 2980G Switches Command Reference*.

This chapter consists of these sections:

- [Understanding How PortFast Works, page 8-1](#)
- [Understanding How PortFast BPDU Guard Works, page 8-2](#)
- [Understanding How PortFast BPDU Filtering Works, page 8-2](#)
- [Understanding How UplinkFast Works, page 8-3](#)
- [Understanding How BackboneFast Works, page 8-4](#)
- [Understanding How Loop Guard Works, page 8-6](#)
- [Configuring PortFast, page 8-8](#)
- [Configuring PortFast BPDU Guard, page 8-11](#)
- [Configuring PortFast BPDU Filtering, page 8-13](#)
- [Configuring UplinkFast, page 8-15](#)
- [Configuring BackboneFast, page 8-17](#)
- [Configuring Loop Guard, page 8-18](#)

Understanding How PortFast Works

PortFast causes a switch or trunk port to enter the spanning tree forwarding state immediately, bypassing the listening and learning states.

You can use PortFast on switch or trunk ports connected to a single workstation, switch, or server to allow those devices to connect to the network immediately, instead of waiting for the port to transition from the listening and learning states to the forwarding state.

**Caution**

You can use PortFast to connect a single end station or a switch port to a switch port. If you enable PortFast on a port that is connected to another Layer 2 device, such as a switch, you might create network loops.

When the switch powers up, or when a device is connected to a port, the port normally enters the spanning tree listening state. When the Forward Delay timer expires, the port enters the learning state. When the Forward Delay timer expires a second time, the port is transitioned to the forwarding or blocking state.

When you enable PortFast on a switch or trunk port, the port is immediately transitioned to the spanning tree forwarding state.

Understanding How PortFast BPDU Guard Works

To prevent loops from occurring in a network, the PortFast mode is supported only on nontrunking access ports because these ports typically do not transmit or receive BPDUs. The most secure implementation of PortFast is to enable it only on ports that connect end stations to switches. Because PortFast can be enabled on nontrunking ports connecting two switches, spanning tree loops can occur because BPDUs are still being transmitted and received on those ports.

The PortFast BPDU guard feature prevents loops by moving a nontrunking port into an errdisable state when a BPDU is received on that port. When the BPDU guard feature is enabled on the switch, spanning tree shuts down PortFast-configured interfaces that receive BPDUs, instead of putting them into the spanning tree blocking state. In a valid configuration, PortFast-configured interfaces do not receive BPDUs. If a PortFast-configured interface receives a BPDU, an invalid configuration exists, such as connection of an unauthorized device. The BPDU guard feature provides a secure response to invalid configurations because the administrator must manually put the interface back in service.

**Note**

When enabled on the switch, spanning tree applies the BPDU guard feature to all PortFast-configured interfaces.

Understanding How PortFast BPDU Filtering Works

BPDU filtering allows you to avoid transmitting BPDUs on PortFast-enabled ports that are connected to an end system. When you enable PortFast on the switch, spanning tree places ports in the forwarding state immediately, instead of going through the listening, learning, and forwarding states.

By default, spanning tree sends BPDUs from all ports regardless of whether PortFast is enabled. BPDU filtering is on a per-switch basis; after you enable BPDU filtering, it applies to all PortFast-enabled ports on the switch.

Understanding How UplinkFast Works

UplinkFast provides fast convergence using uplink groups in the network access layer after a spanning tree topology change. An uplink group is a set of ports (per VLAN), only one of which is forwarding at any given time. Specifically, an uplink group consists of the root port (which is forwarding) and a set of blocked ports (not including self-looped ports). The uplink group provides an alternate path in case the currently forwarding link fails.



Note

UplinkFast is most useful in wiring-closet switches that have a limited number of active VLANs. This enhancement might not be useful for other types of applications and should not be enabled on backbone or distribution layer switches.

Figure 8-1 shows an example UplinkFast network topology. Switch A, the root switch, is connected directly to Switch B over link L1 and to Switch C over link L2. The port on Switch C that is connected to Switch B over link L3 is in blocking state.

Figure 8-1 UplinkFast Example Before Direct Link Failure

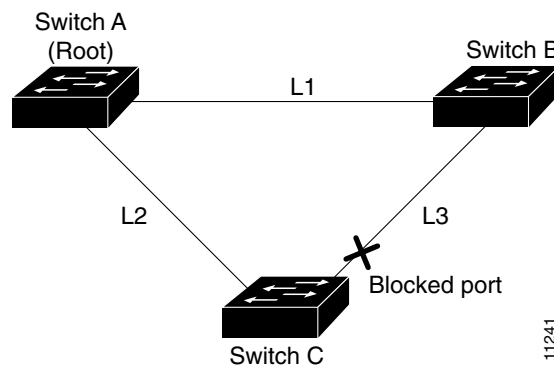

If Switch C detects a link failure on the currently active link L2 (a *direct* link failure), UplinkFast unblocks the blocked port on Switch C and transitions it to the forwarding state immediately, without transitioning the port through the listening and learning states (as shown in Figure 8-2). This switchover takes approximately 1 to 5 seconds.

Figure 8-2 Example of UplinkFast After Direct Link Failure

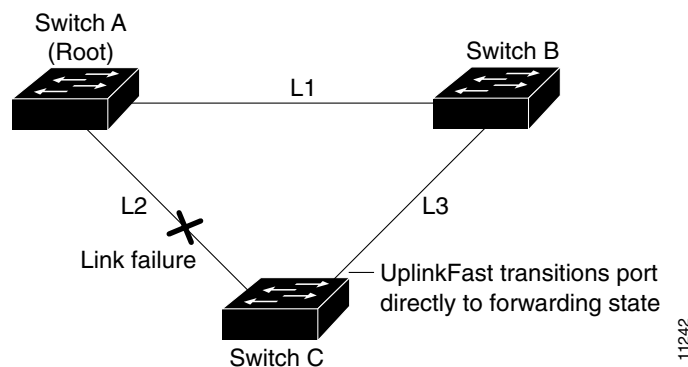

As soon as the switch transitions the alternate port to the forwarding state, the switch begins transmitting dummy multicast frames on that port, one for each entry in the local Enhanced Address Recognition Logic (EARL) table (except those entries that are associated with the failed root port). By default, approximately 15 dummy multicast frames are transmitted per 100 ms.

Each dummy multicast frame uses the station address in the EARL table entry as its source MAC address and a dummy multicast address (01-00-0C-CD-CD-CD) as the destination MAC address.

Switches receiving these dummy multicast frames immediately update their EARL table entries for each source MAC address to use the new port, allowing the switches to begin using the new path almost immediately.

If connectivity on the original root port is restored, the switch waits for a period equal to twice the forward delay time plus 5 seconds before transitioning the port to the forwarding state to allow the neighbor port enough time to transition through the listening and learning states to the forwarding state.

Understanding How BackboneFast Works

BackboneFast provides fast convergence in the network backbone after a spanning tree topology change occurs. A switch detects an indirect link failure (the failure of a link to which the switch is not directly connected) when the switch receives inferior BPDUs from its designated bridge on its root port or blocked ports. These inferior BPDUs indicate that the designated bridge has lost its connection to the root bridge. An inferior BPDU identifies a single switch as both the root bridge and the designated bridge. Under normal spanning tree rules, the switch ignores inferior BPDUs for the configured maximum aging time (specified by the **set spantree maxage** command).

The switch tries to determine if it has an alternate path to the root bridge. If the inferior BPDU arrives on a blocked port, the root port and other blocked ports on the switch become alternate paths to the root bridge. If the inferior BPDU arrives on the root port, all blocked ports become alternate paths to the root bridge. If the inferior BPDU arrives on the root port and there are no blocked ports, the switch assumes that it has lost connectivity to the root bridge, causes the maximum aging time on the root to expire, and becomes the root switch according to normal spanning tree rules.

If the switch has alternate paths to the root bridge, it uses these alternate paths to transmit a new kind of protocol data unit (PDU) called the Root Link Query PDU out all alternate paths to the root bridge. If the switch determines that it still has an alternate path to the root, it causes the maximum aging time on the ports on which it received the inferior BPDU to expire. If all the alternate paths to the root bridge indicate that the switch has lost connectivity to the root bridge, the switch causes the maximum aging times on the ports on which it received an inferior BPDU to expire. If one or more alternate paths can still connect to the root bridge, the switch makes all ports on which it received an inferior BPDU its designated ports and moves them out of the blocking state (if they were in the blocking state), through the listening and learning states, and into the forwarding state.

Figure 8-3 shows an example of a BackboneFast network topology. Switch A, the root switch, connects directly to Switch B over link L1 and to Switch C over link L2. The port on Switch C that connects directly to Switch B over link L3 is in the blocking state.

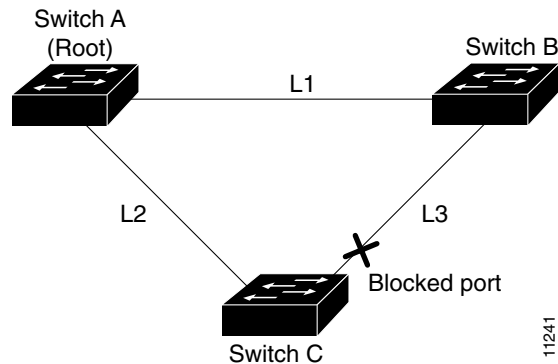
Figure 8-3 Example of BackboneFast before Indirect Link Failure

If link L1 fails, Switch C detects this failure as an *indirect* failure, since it is not connected directly to link L1. Switch B no longer has a path to the root switch. BackboneFast allows the blocked port on Switch C to move immediately to the listening state without waiting for the maximum aging time for the port to expire. BackboneFast then transitions the port on Switch C to the forwarding state, providing a path from Switch B to Switch A. This switchover takes approximately 30 seconds. [Figure 8-4](#) shows how BackboneFast reconfigures the topology to account for the failure of link L1.

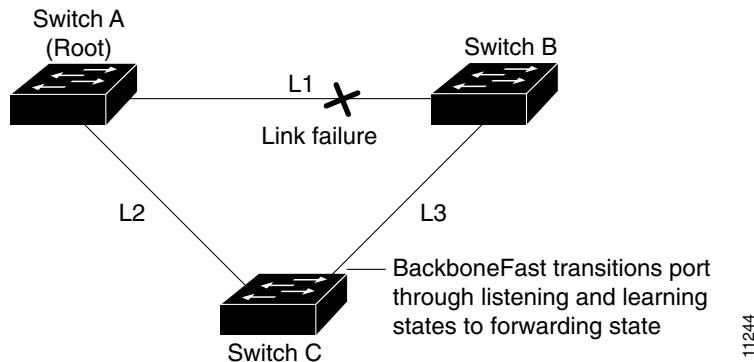
Figure 8-4 Example of BackboneFast after Indirect Link Failure

If a new switch is introduced into a shared-medium topology, BackboneFast is not activated. [Figure 8-5](#) shows a shared-medium topology in which a new switch is added. The new switch begins sending inferior BPDUs, which indicate that it is the root switch. However, the other switches ignore these inferior BPDUs and the new switch learns that Switch B is the designated bridge to Switch A, the root switch.

Figure 8-5 Adding a Switch in a Shared-Medium Topology

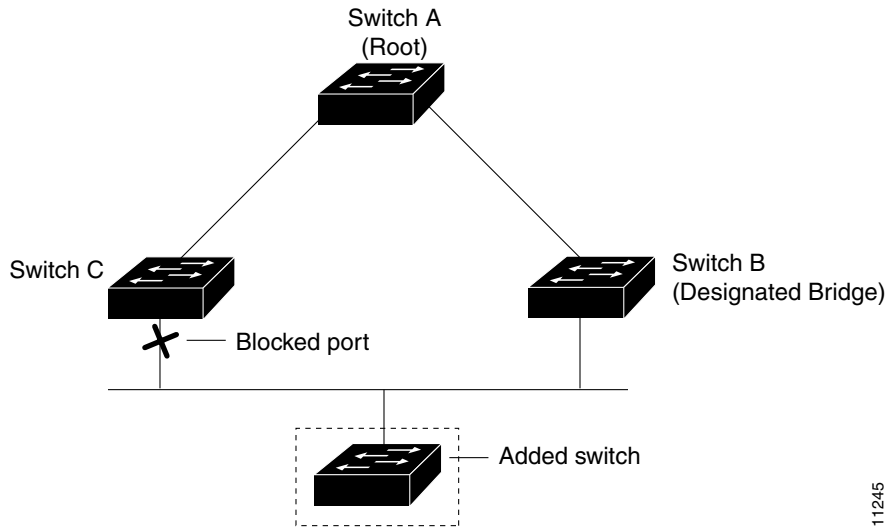

11245

Understanding How Loop Guard Works

Unidirectional link failures may cause a root port or alternate port to become designated as root if BPDUs are absent. Some software failures may introduce temporary loops in the network. The loop guard feature checks if a root port or an alternate root port receives BPDUs. If the port is receiving BPDUs, the loop guard feature puts the port into an inconsistent state until it starts receiving BPDUs again. Loop guard isolates the failure and lets spanning tree converge to a stable topology without the failed link or bridge.

You can enable loop guard on a per-port basis with the **set spantree guard loop** command.



Note

Provided that you are in MST mode, you can set all the ports on a switch with the **set spantree global-defaults loop-guard** command.

When you enable loop guard, it is automatically applied to all of the active instances or VLANs to which that port belongs. When you disable loop guard, it is disabled for the specified ports. Disabling loop guard moves all loop-inconsistent ports to the listening state.

If you enable loop guard on a channel and the first link becomes unidirectional, loop guard blocks the entire channel until the affected port is removed from the channel. [Figure 8-6](#) shows loop guard in a triangle switch configuration.

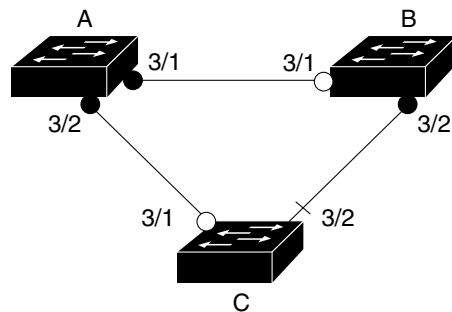
Figure 8-6 Triangle Switch Configuration with Loop Guard

—● Designated port

—○ Root port

—+ Alternate port

55772

Figure 8-6 illustrates the following configuration:

- Switches A and B are distribution switches.
- Switch C is an access switch.
- Loop guard is enabled on ports 3/1 and 3/2 on Switches A, B, and C.

Use loop guard only in topologies where there are blocked ports. Topologies that have no blocked ports, which are loop free, do not need to enable this feature. Enabling loop guard on a root switch has no effect but provides protection when a root switch becomes a nonroot switch.

Follow these guidelines when using loop guard:

- Do not enable loop guard on PortFast-enabled or dynamic VLAN ports.
- Do not enable PortFast on loop guard-enabled ports.
- Do not enable loop guard if root guard is enabled.
- Do not enable loop guard on ports that are connected to a shared link.



Note We recommend that you enable loop guard on root ports and alternate root ports on access switches.

Loop guard interacts with other features as follows:

- Loop guard does not affect the functionality of UplinkFast or BackboneFast.
- Root guard forces a port to always be designated as the root port. Loop guard is effective only if the port is a root port or an alternate port. Do not enable loop guard and root guard on a port at the same time.
- PortFast transitions a port into a forwarding state immediately when a link is established. Because a PortFast-enabled port will not be a root port or alternate port, loop guard and PortFast cannot be configured on the same port. Assigning dynamic VLAN membership for the port requires that the port is PortFast enabled. Do not configure a loop guard-enabled port with dynamic VLAN membership.
- If your network has a type-inconsistent port or a PVID-inconsistent port, all BPDUs are dropped until the misconfiguration is corrected. The port transitions out of the inconsistent state after the message age expires. Loop guard ignores the message age expiration on type-inconsistent ports and

PVID-inconsistent ports. If the port is already blocked by loop guard, misconfigured BPDUs received on the port make loop guard recover, but the port is moved into the type-inconsistent state or PVID-inconsistent state.

- In high-availability switch configurations, if a port is put into the blocked state by loop guard, it remains blocked even after switchover to the redundant supervisor engine. The newly activated supervisor engine recovers the port only after receiving a BPDU on that port.
- Loop guard uses the ports known to spanning tree. Loop guard can take advantage of logical ports provided by the Port Aggregation Protocol (PAgP). However, to form a channel, all the physical ports grouped in the channel must have compatible configurations. PAgP enforces uniform configurations of root guard or loop guard on all the physical ports to form a channel.

These caveats apply to loop guard:

- Spanning tree always chooses the first operational port in the channel to send the BPDUs. If that link becomes unidirectional, loop guard blocks the channel, even if other links in the channel are functioning properly.
- If a set of ports that are already blocked by loop guard are grouped together to form a channel, spanning tree loses all the state information for those ports and the new channel port may obtain the forwarding state with a designated role.
- If a channel is blocked by loop guard and the channel breaks, spanning tree loses all the state information. The individual physical ports may obtain the forwarding state with the designated role, even if one or more of the links that formed the channel are unidirectional.
- You can enable UniDirectional Link Detection (UDLD) to help isolate the link failure. A loop may occur until UDLD detects the failure, but loop guard will not be able to detect it.
- Loop guard has no effect on a disabled spanning tree instance or a VLAN.

Configuring PortFast

The following sections describe how to configure PortFast on the switch.

Enabling PortFast on an Access Port



Caution

You can use PortFast to connect a single end station or a switch port to a switch port. If you enable PortFast on a port that is connected to another Layer 2 device, such as a switch, you might create network loops.

To enable PortFast on a switch port, perform this task in privileged mode:

	Task	Command
Step 1	Enable PortFast on a switch port connected to a single workstation, switch, or server.	set spantree portfast <i>mod_num/port_num</i> enable disable
Step 2	Verify the PortFast setting on a switch port.	show spantree [<i>mod_num/port_num</i>] [<i>vlan</i>]

This example shows how to enable PortFast on port 1 of module 4 and verify the configuration (the PortFast status is shown in the “Fast-Start” column):

```

Console> (enable) set spantree portfast 4/1 enable
Warning:Connecting Layer 2 devices to a fast start port can cause
temporary spanning tree loops. Use with caution.

Spantree port 4/1 fast start enabled.
Console> (enable) show spantree 4/1
Port      Vlan  Port-State      Cost   Priority  Fast-Start  Group-method
-----
4/1      1    blocking        19     20       enabled
4/1     100  forwarding       10     20       enabled
4/1     521  blocking        19     20       enabled
4/1     522  blocking        19     20       enabled
4/1     523  blocking        19     20       enabled
4/1     524  blocking        19     20       enabled
4/1    1003  not-connected   19     20       enabled
4/1    1005  not-connected   19     4        enabled
Console> (enable)

```

Enabling PortFast on a Trunk Port



Caution

You can use PortFast to connect a single end station or a switch port to a switch port. If you enable PortFast on a port that is connected to another Layer 2 device, like a switch, you might create network loops.

To enable PortFast on a trunk port, perform this task in privileged mode:

	Task	Command
Step 1	Enable PortFast on a trunk port that is connected to a single workstation, switch, or server.	set spantree portfast <i>mod_num/port_num</i> enable trunk Note If you enter the set spantree portfast command on a trunk port without entering the trunk keyword, the trunk port stays in disable mode.
Step 2	Verify the PortFast setting on a trunk port.	show spantree portfast [<i>mod_num/port_num</i>]

This example shows how to enable PortFast on port 1 of module 4 of a trunk port, bring the trunk port to a forwarding state, and verify the configuration (the PortFast status is shown in the “Fast-Start” column):

```

Console> (enable) set spantree portfast 4/1 enable trunk
Warning:Connecting Layer 2 devices to a fast start port can cause
temporary spanning tree loops. Use with caution.

Spantree port 4/1 fast start enabled.
Console> (enable) show spantree 4/1
Port      Vlan  Port-State      Cost   Prio  Portfast
Channel_id
-----
4/1      1    blocking        19     4     32  enabled  0
4/1     100  forwarding       10     4     32  enabled  0
4/1     521  blocking        19     4     32  enabled  0
4/1     524  blocking        19     4     32  enabled  0
4/1    1003  not-connected   19     4     32  enabled  0

```

```

4/1          1005 not-connected      4   32 enabled  0
Console> (enable) show spantree portfast 4/1
Portfast:enable trunk
Portfast BPDU guard is disabled.
Portfast BPDU filter is disabled.
Console>

```

**Note**

When you enable PortFast between two switches, the system will verify that there are no loops in the network before bringing the blocking trunk to a forwarding state.

Disabling PortFast

To disable PortFast on a switch or trunk port, perform this task in privileged mode:

	Task	Command
Step 1	Disable PortFast on a switch port.	set spantree portfast <i>mod_num/port_num</i> disable
Step 2	Verify the PortFast setting.	show spantree <i>mod_num/port_num</i>

This example shows how to disable PortFast on port 1 of module 4:

```

Console> (enable) set spantree portfast 4/1 disable
Spantree port 4/1 fast start disabled.
Console> (enable)

```

To reset PortFast on a switch or trunk port to its default settings, perform this task in privileged mode:

	Task	Command
Step 1	Reset PortFast to default setting on a switch port.	set spantree portfast <i>mod_num/port_num</i> default
Step 2	Verify the PortFast setting.	show spantree <i>mod_num/port_num</i>

This example shows how to disable PortFast on port 1 of module 4:

```

Console> (enable) set spantree portfast 4/1 default

Spantree port 4/1 fast start set to default.

Console> (enable) show spantree portfast 4/1
Portfast:default
Portfast BPDU guard is disabled.
Portfast BPDU filter is disabled.
Console> (enable)

```

Resetting PortFast

To reset PortFast on a switch or trunk port to its default settings, perform this task in privileged mode:

	Task	Command
Step 1	Reset PortFast to its default settings on a switch port.	set spantree portfast <i>mod_num/port_num</i> default
Step 2	Verify the PortFast setting.	show spantree <i>mod_num/port_num</i>

This example shows how to reset PortFast to its default settings on port 1 of module 4:

```
Console> (enable) set spantree portfast 4/1 default
```

```
Spanntree port 4/1 fast start set to default.
```

```
Console> (enable) show spantree portfast 4/1
```

```
Portfast:default
```

```
Portfast BPDU guard is disabled.
```

```
Portfast BPDU filter is disabled.
```

```
Console> (enable)
```

Configuring PortFast BPDU Guard

The following sections describe how to configure PortFast BPDU guard on the switch.

Enabling PortFast BPDU Guard

The PortFast feature is configured on an individual port, and the PortFast BPDU guard option is configured either globally or on a per-port basis.

When you disable PortFast on a port, PortFast BPDU guard becomes inactive. The port configuration overrides the global configuration unless the port configuration is set to default. If the port configuration is set to default, the global configuration is checked. If the port configuration is enabled, the port configuration is used and the global configuration is not used.

To enable and verify PortFast BPDU guard on a nontrunking switch port, perform this task in privileged mode:

	Task	Command
Step 1	Enable BPDU guard on an individual port.	set spantree portfast bpdu-guard <i>mod/port</i> [disable enable default]
Step 2	Verify the PortFast BPDU guard setting.	show spantree summary



Note

For additional PVST+ information, see [Chapter 7, “Configuring Spanning Tree.”](#)

This example shows how to enable PortFast BPDU guard on module 6 port 1, and verify the configuration in the Per VLAN Spanning Tree + (PVST+) mode:

```
Console> (enable) set spantree portfast bpdu-guard 6/1 enable
Spantree port 6/1 bpdu guard enabled.
Console> (enable)
Console> (enable) show spantree summary
Root switch for vlans: none.
Portfast bpdu-guard enabled for bridge.
Uplinkfast disabled for bridge.
Backbonefast disabled for bridge.
```

Vlan	Blocking	Listening	Learning	Forwarding	STP Active
1	0	0	0	4	4
2	0	0	0	4	4
3	0	0	0	4	4
4	0	0	0	4	4
5	0	0	0	4	4
6	0	0	0	4	4
10	0	0	0	4	4
20	0	0	0	4	4
.					
.					
.					
999	0	0	0	4	4
1003	0	0	0	0	0
1005	0	0	0	0	0
	Blocking	Listening	Learning	Forwarding	STP Active
Total	0	0	0	85	85

```
Console> (enable)
```

Disabling PortFast BPDU Guard

To disable PortFast BPDU guard, perform this task in privileged mode:

	Task	Command
Step 1	Disable PortFast BPDU guard on the switch.	<code>set spantree portfast bpdu-guard mod/port [disable enable default]</code>
Step 2	Verify the PortFast BPDU guard setting.	<code>show spantree summary</code>

This example shows how to disable PortFast BPDU guard on the switch and verify the configuration:

```
Console> (enable) set spantree portfast bpdu-guard disable
Spantree portfast bpdu-guard disabled on this switch.
Console> (enable) show spantree summary
Summary of connected spanning tree ports by vlan
```

```
→ Portfast bpdu-guard disabled for bridge.
Uplinkfast disabled for bridge.
Backbonefast disabled for bridge.
```

Vlan	Blocking	Listening	Learning	Forwarding	STP Active
1	0	0	0	4	4
2	0	0	0	4	4

```

      3          0          0          0          4          4
      4          0          0          0          4          4
      .
      .
      .
    1003          0          0          0          0          0
    1005          0          0          0          0          0

          Blocking Listening Learning Forwarding STP Active
-----
Total          0          0          0          85          85
Console> (enable)

```

Configuring PortFast BPDU Filtering

The following sections describe how to configure PortFast BPDU filtering on the switch.

Enabling PortFast BPDU Filtering



Note

Although you can configure PortFast on an individual port, you configure the PortFast BPDU filtering option globally. When you disable PortFast on a port, PortFast BPDU filtering becomes inactive for that port.

To enable PortFast BPDU filtering, perform this task in privileged mode:

	Task	Command
Step 1	Enable BPDU filtering state on the port.	set spantree portfast bpdu-filter <i>mod/port</i> [disable enable default]
Step 2	Verify PortFast BPDU filtering setting.	show spantree summary



Note

For additional PVST+ information, see [Chapter 7, “Configuring Spanning Tree.”](#)

By default, BPDU filtering is set for each port. This example shows how to enable PortFast BPDU filtering on the port and verify the configuration in PVST+ mode:

```

Console> (enable) set spantree portfast bpdu-filter 6/1 enable
Warning:Ports enabled with bpdu filter will not send BPDUs and drop all
received BPDUs. You may cause loops in the bridged network if you misuse
this feature.

```

```

Console> (enable) show spantree summary
Root switch for vlans: none.
Portfast bpdu-filter enabled for bridge.
Uplinkfast disabled for bridge.
Backbonefast disabled for bridge.

```

```

Vlan  Blocking Listening Learning Forwarding STP Active
-----
      1          0          0          0          4          4

```

```

      2          0          0          0          4          4
      3          0          0          0          4          4
      4          0          0          0          4          4
      5          0          0          0          4          4
      6          0          0          0          4          4
      .
      .
      .
1003          0          0          0          0          0
1005          0          0          0          0          0

          Blocking Listening Learning Forwarding STP Active
-----
Total          0          0          0          85          85
Console> (enable)

```

Disabling PortFast BPDU Filtering

To disable PortFast BPDU filtering on a switch, perform this task in privileged mode:

	Task	Command
Step 1	Disable PortFast BPDU filtering on the switch.	set spantree portfast bpdu-filter disable
Step 2	Verify the PortFast BPDU filtering setting.	show spantree summary

This example shows how to disable PortFast BPDU filtering on the switch and verify the configuration:

```

Console> (enable) set spantree portfast bpdu-filter disable
Spantree portfast bpdu-filter disabled on this switch.
Console> (enable) show spantree summary
Summary of connected spanning tree ports by vlan

```

```

Portfast bpdu-filter disabled for bridge.
Uplinkfast disabled for bridge.
Backbonefast disabled for bridge.

```

```

Vlan  Blocking Listening Learning Forwarding STP Active
-----
      1          0          0          0          4          4
      2          0          0          0          4          4
      3          0          0          0          4          4
      4          0          0          0          4          4
      5          0          0          0          4          4
      6          0          0          0          4          4
     10          0          0          0          4          4
      .
      .
      .
     999          0          0          0          4          4
    1003          0          0          0          0          0
    1005          0          0          0          0          0

          Blocking Listening Learning Forwarding STP Active
-----
Total          0          0          0          85          85
Console> (enable)

```

Configuring UplinkFast

The following sections describe how to configure the UplinkFast feature on the switch.

Enabling UplinkFast

When you enable UplinkFast on the switch, UplinkFast processing is enabled and the spanning tree bridge priority for all VLANs is set to 49,152, making it unlikely that the switch will become the root switch. In addition, the spanning tree port cost and port-VLAN cost of all ports on the switch is increased by 3000.

The *station_update_rate* value in the UplinkFast command represents the number of dummy multicast packets that are transmitted per 100 ms (the default is 15 packets per 100 ms) in the event of a direct link failure.

Enter the **all-protocols on** keywords on switches that have UplinkFast enabled but do not have protocol filtering enabled, and that are connected to upstream switches in the network that have protocol filtering enabled. The **all-protocols on** keywords cause the switch to generate multicasts for each protocol-filtering group.

On switches with both UplinkFast and protocol filtering enabled, or if no other switches have protocol filtering enabled, you do not need to use the **all-protocols on** keywords.



Note

When you enable UplinkFast, it affects all VLANs on the switch. You cannot configure UplinkFast on a per-VLAN basis.

To enable UplinkFast, perform this task in privileged mode:

	Task	Command
Step 1	Enable UplinkFast on the switch.	set spantree uplinkfast enable [<i>rate station_update_rate</i>] [all-protocols {off on}]
Step 2	Verify that UplinkFast is enabled.	show spantree uplinkfast [<i>vlangs</i>]

This example shows how to enable UplinkFast with a station-update rate of 40 packets per 100 ms and how to verify that UplinkFast is enabled:

```

Console> (enable) set spantree uplinkfast enable rate 40
VLANs 1-1005 bridge priority set to 49152.
The port cost and portvlancost of all ports set to above 3000.
Station update rate set to 40 packets/100ms.
uplinkfast all-protocols field set to off.
uplinkfast enabled for bridge.
Console> (enable) show spantree uplinkfast
Station update rate set to 40 packets/100ms.
uplinkfast all-protocols field set to off.
VLAN          port list
-----
```

```

1          1/1 (fwd) , 1/2
100       1/2 (fwd)
521       1/1 (fwd) , 1/2
522       1/1 (fwd) , 1/2
523       1/1 (fwd) , 1/2
524       1/1 (fwd) , 1/2
Console> (enable)

```

This example shows how to display the UplinkFast feature settings for all VLANs:

```

Console> show spantree uplinkfast
Station update rate set to 15 packets/100ms.
uplinkfast all-protocols field set to off.
VLAN port list
-----
1-20     1/1 (fwd) , 1/2-1/5
21-50    1/9 (fwd) , 1/6-1/8 , 1/10-1/12
51-100   2/1 (fwd) , 2/12
Console>

```

Disabling UplinkFast

To disable UplinkFast and restore the default spanning tree bridge priority, port cost, and port-VLAN cost values to their default values, enter the **clear spantree uplinkfast** command.



Caution

Use caution when entering the **clear spantree uplinkfast** command. This command restores the port-VLAN costs on all ports to the default minus one (18) and the port cost to the default value (19). If you have configured per-VLAN load sharing on redundant trunk links, the load-sharing configuration can be affected by this command.

You can disable only spanning tree UplinkFast processing on the switch using the **set spantree uplinkfast disable** command. This command does not affect the bridge priority, port cost, and port-VLAN cost values on the switch.



Note

When you disable UplinkFast, it affects all VLANs on the switch. You cannot disable UplinkFast on a per-VLAN basis.

To disable UplinkFast on a switch, perform this task in privileged mode:

	Task	Command
Step 1	(Optional) Disable UplinkFast processing on the switch and restore the default bridge priority, port cost, and port-VLAN cost values.	clear spantree uplinkfast
Step 2	(Optional) Disable UplinkFast processing on the switch without affecting the bridge priority, port cost, and port-VLAN cost values.	set spantree uplinkfast disable
Step 3	Verify that UplinkFast is enabled.	show spantree uplinkfast

This example shows how to disable UplinkFast on the switch and restore the default bridge priority, port cost, and port-VLAN cost values:

```

Console> (enable) clear spantree uplinkfast
This command will cause all portcosts, portvlancosts, and the
bridge priority on all vlans to be set to default.
Do you want to continue (y/n) [n]? y
VLANs 1-1005 bridge priority set to 32768.
The port cost of all bridge ports set to default value.
The portvlancost of all bridge ports set to default value.
uplinkfast all-protocols field set to off.
uplinkfast disabled for bridge.
Console> (enable) show spantree uplinkfast
uplinkfast disabled for bridge.
Console> (enable)

```

Configuring BackboneFast

The following sections describe how to configure the BackboneFast feature on the switch.

Enabling BackboneFast



Note

You must enable BackboneFast on all switches in the network. BackboneFast is not supported on Token Ring VLANs. This feature is supported for use with third-party switches.

To enable BackboneFast on the switch, perform this task in privileged mode:

	Task	Command
Step 1	Enable BackboneFast on the switch.	set spantree backbonefast enable
Step 2	Verify that BackboneFast is enabled.	show spantree backbonefast

This example shows how to enable BackboneFast on the switch and how to verify the configuration:

```

Console> (enable) set spantree backbonefast enable
Backbonefast enabled for all VLANs
Console> (enable) show spantree backbonefast
Backbonefast is enabled.
Console> (enable)

```

Displaying BackboneFast Statistics

To display BackboneFast statistics, perform this task in privileged mode:

Task	Command
Display BackboneFast statistics.	show spantree summary

This example shows how to display BackboneFast statistics:

```

Console> (enable) show spantree summary
Summary of connected spanning tree ports by vlan

Uplinkfast disabled for bridge.
Backbonefast enabled for bridge.

Vlan  Blocking Listening Learning Forwarding STP Active
-----
   1      0       0       0       1       1

      Blocking Listening Learning Forwarding STP Active
-----
Total      0       0       0       1       1

BackboneFast statistics
-----
Number of inferior BPDUs received (all VLANs) : 0
Number of RLQ req PDUs received (all VLANs)   : 0
Number of RLQ res PDUs received (all VLANs)   : 0
Number of RLQ req PDUs transmitted (all VLANs): 0
Number of RLQ res PDUs transmitted (all VLANs): 0
Console> (enable)

```

Disabling BackboneFast

To disable BackboneFast on the switch, perform this task in privileged mode:

	Task	Command
Step 1	Disable BackboneFast on the switch.	set spantree backbonefast disable
Step 2	Verify that BackboneFast is disabled.	show spantree backbonefast

This example shows how to disable BackboneFast on the switch and how to verify the configuration:

```

Console> (enable) set spantree backbonefast disable
Backbonefast enabled for all VLANs
Console> (enable) show spantree backbonefast
Backbonefast is disabled.
Console> (enable)

```

Configuring Loop Guard

The following sections describe how to configure loop guard.

Enabling Loop Guard

Enter the **set spantree guard** command to enable the spanning tree loop guard feature on a per-port basis. To set all the ports on the switch, use the **set spantree mst global-defaults loop-guard** command.

To enable loop guard on an individual port, perform this task in privileged mode:

	Task	Command
Step 1	Enable loop guard on a port.	set spantree guard { root loop none } <i>mod/port</i>
Step 2	Verify that loop guard is enabled.	show spantree guard { <i>mod/port</i> <i>vlan</i> } mistp-instance <i>instance</i>

This example shows how to enable loop guard on port 5/1:

```
Console> (enable) set spantree guard loop 5/1
Rootguard is enabled on port 5/1, enabling loopguard will disable rootguard on
this port.
Do you want to continue (y/n) [n]? y
Loopguard on port 5/1 is enabled.
Console> (enable)
```

This example shows how to enable loop guard on all the ports on a switch:

```
Console> (enable) set spantree mst global-defaults loop-guard enable
Spantree global loop-guard state enabled on this switch.
```

Disabling Loop Guard

Enter the **set spantree guard** command to disable the spanning tree loop guard feature on a per-port basis. To disable loop guard on all the ports on a switch, use the **set spantree mst global-defaults loop-guard** command.

To disable loop guard on the switch, perform this task in privileged mode:

	Task	Command
Step 1	Disable loop guard on a port.	set spantree guard { root loop none } <i>mod/port</i>
Step 2	Verify that loop guard is disabled.	show spantree guard { <i>mod/port</i> <i>vlan</i> } mistp-instance <i>instance</i>

This example shows how to disable loop guard on port 5/1:

```
Console> (enable) set spantree guard none 5/1
Rootguard is disabled on port 5/1, disabling loopguard will disable rootguard on
this port.
Do you want to continue (y/n) [n]? y
Loopguard on port 5/1 is disabled.
Console> (enable)
```

This example shows how to disable loop guard on all the ports on a switch:

```
Console> (enable) set spantree mst global-defaults loop-guard disable
Spantree global loop-guard state disabled on this switch.
```

