



Configuring Switch Acceleration

This chapter describes the Backplane Channel module and the switch acceleration feature supported on the Catalyst 4000 family supervisor engine.

This chapter consists of these sections:

- [Understanding Switch Acceleration, page 32-1](#)
- [Configuring Switch Acceleration, page 32-3](#)
- [Backplane Channel Module, page 32-4](#)



Note

For complete syntax and usage information for the commands used in this chapter, refer to the *Command Reference—Catalyst 4000 Family, Catalyst 2948G, and Catalyst 2980G Switches*.

Understanding Switch Acceleration

The switch acceleration feature provides the following supervisor engine performance benefits:

- Increased bandwidth between switch engines
- Full-mesh connectivity between switch engines
- Reduced internal traffic congestion

The switch acceleration feature is supported on Catalyst 4006 switches with Supervisor Engine II and on the Catalyst 4000 family Backplane Channel module. The switch acceleration feature reduces internal traffic congestion by creating a full-mesh connection between the switch engines (SEs). The Supervisor Engine II has three switch engines that switch traffic to and from the modules and the uplink ports. This chapter refers to these switch engines as SE1, SE2, and SE3.

- SE1 handles traffic for Gigabit Ethernet uplink port 1/1 and traffic between modules installed in the chassis.
- SE3 handles traffic for Gigabit Ethernet uplink port 1/2 and traffic between modules installed in the chassis.
- SE2 switches internal traffic and forwards traffic bound for the uplink ports to the correct SE for that port.

By default, there is no direct internal connection between SE1 and SE3. As a result, traffic coming in on SE1 destined for SE3 or vice versa must go through SE2, which could potentially create congestion. To avoid such congestion, you can disable the uplink ports and create a direct internal link between SE1 and SE3.

Switch Acceleration Configuration Modes

Switch acceleration is supported in different configuration modes. The Supervisor Engine II supports a mesh configuration with no uplink connections. With the Backplane Channel module installed, two additional modes are supported.

Figure 32-1 shows the possible configurations.

Figure 32-1 Switch Acceleration Configuration Modes

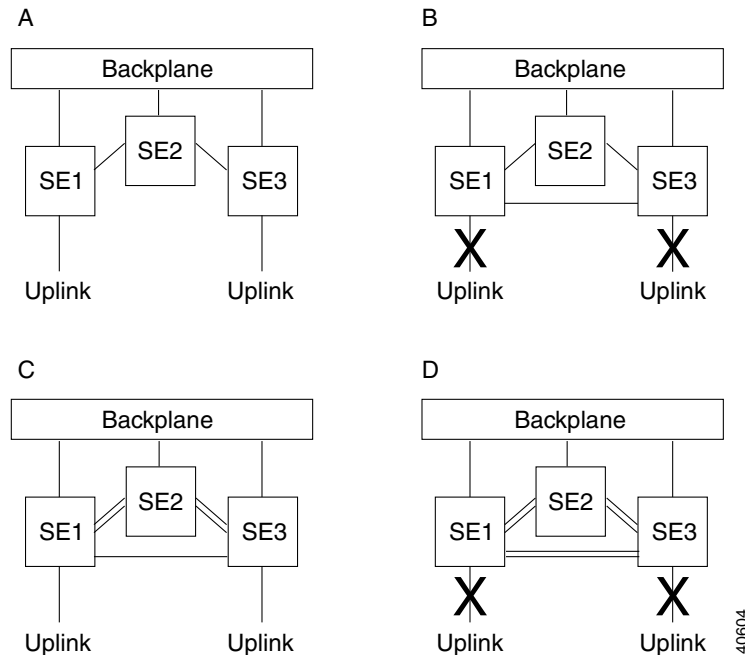

- Option A—no switch acceleration configured (default).
- Option B—Fully meshed interconnections between SEs; no Gigabit Ethernet uplink port connections.

This mode requires that you enable switch acceleration on the supervisor engine.

- Option C—Fully meshed interconnections between SEs; dual-link load-balancing between SE1 and SE2 and between SE2 and SE3; Gigabit Ethernet uplink port connections.

This mode requires that the Backplane Channel module is installed and that switch acceleration is configured on the supervisor engine.

- Option D—Fully meshed interconnections and multi link load balancing between all SEs; no Gigabit Ethernet uplink port connections.

This mode requires that the Backplane Channel module is installed and that switch acceleration is configured on the supervisor engine.

Configuring Switch Acceleration

By default, switch acceleration is disabled on the Supervisor Engine II.

Before you enable switch acceleration, you need to disable the two front-panel Gigabit Ethernet uplink ports on Supervisor Engine II.

To enable switch acceleration, perform this task in privileged mode:

	Task	Command
Step 1	Disable front-panel Gigabit Ethernet ports.	set port disable <i>mod_num/port_num</i>
Step 2	Enable switch acceleration.	set switchacceleration {enable disable} <i>mod-num</i>

This example shows how to enable switch acceleration on the switch:

```
Console> (enable) set port disable 1/1-2
Port(s) 1/1-2 disabled.
Console> (enable)
```

```
Console> (enable) set switchacceleration enable 1
Enabling or Disabling switch acceleration may impact performance for 1-2 seconds.
Do you want to continue (y/n) [n]? y
Switch Acceleration on module 1 enabled.
Console> (enable)
```

This example shows how to disable switch acceleration on the switch:

```
Console> (enable) set switchacceleration disable 1
Enabling or Disabling switch acceleration may impact performance for 1-2 seconds.
Do you want to continue (y/n) [n]? y
Switch Acceleration on module 1 disabled.
Console> (enable)
```

Displaying Switch Acceleration Information

To display switch acceleration status, perform this task in privileged mode:

Task	Command
Display current status of switch acceleration.	show switchacceleration <i>mod_num</i>

This example shows how to display the current status of the switch acceleration feature:

```
Console> show switchacceleration 1
Module 1 has switch acceleration enabled.
Console>
```

Backplane Channel Module

The Backplane Channel module extends the benefits of switch acceleration by providing multilink load balancing between the switch engines. A Backplane Channel module also allows you to retain the Gigabit Ethernet uplinks on the supervisor engine.

The Backplane Channel module provides the following benefits in the default configuration mode:

- Full-mesh connection between all three switch engines
- Multilink load balancing between SE1 and SE2 and between SE2 and SE3
- Supervisor engine Gigabit Ethernet uplink connections

As an alternative, you can configure switch acceleration on the supervisor engine to get dual-link load balancing between all three SEs.

**Note**

If you want to keep the uplink connections, do not enable switch acceleration on the supervisor engine.

You can insert or remove a Backplane Channel module at any time. When you remove the Backplane Channel module, traffic might be interrupted for a short time. For minimal disruption, disable the Backplane Channel module for a short time, and then remove it.

You do not need to configure the Backplane Channel module because it is enabled by default.