



Installation Notes for the Catalyst 3750-X and 3560-X Switch Power Supply Modules

Published: April, 2010

Revised: April, 2013

For information about using the power supply modules with a switch, see the *Catalyst 3750-X and 3560-X Switch Hardware Installation Guide*. For translations of the safety warnings in this publication, see the *Regulatory Compliance and Safety Information for the Catalyst 3750-X and 3560-X Switch* on Cisco.com:

http://www.cisco.com/en/US/products/ps10745/tsd_products_support_general_information.html

- [Product Overview, page 1](#)
- [Installation Guidelines, page 6](#)
- [Installing or Replacing an AC Power Supply, page 8](#)
- [Installing a DC Power Supply, page 9](#)
- [Finding the Power Supply Module Serial Number, page 13](#)
- [Technical Specifications, page 16](#)
- [Related Publications, page 18](#)
- [Obtaining Documentation and Submitting a Service Request, page 19](#)

Product Overview

The switch operates with either one or two active power supply modules or with power supplied by an expandable power supply, XPS-2200. A Catalyst 3750-X switch that is part of a StackPower stack operates with power supplied by other stack switches.

You can use two AC modules, two DC modules, one AC and one DC module, or one module and a blank cover.

All power supply modules have internal fans. All switches ship with a blank cover in the second power supply slot.



Americas Headquarters:
Cisco Systems, Inc., 170 West Tasman Drive, San Jose, CA 95134-1706 USA

The XPS-2200 operates in two modes:

- In StackPower mode, it supplies power to the switches in the power stack (only Catalyst 3750-X switches with IP Base image).
- In expandable power supply mode, it supplies power to a switch when the switch power supply is removed or fails. When you install or replace a power supply module, the switch software polls the device. After polling, the power supply module provides power to the switch, and the XPS-2200 is available to power other devices.

Table 1 describes the supported internal power supply modules.

Table 1 Power Supply Module Part Numbers and Descriptions

Part Number	Description
C3KX-PWR-1100WAC	1100-W AC power supply module
C3KX-PWR-715WAC	715-W AC power supply module
C3KX-PWR-350WAC	350-W AC power supply module
C3KX-PWR-440WDC	440-W DC power supply module
C3KX-PS-BLANK	Blank cover

Table 2 and Table 3 show the power supply modules available for Catalyst 3750-X and 3560-X switches and power supply configurations based on switch models.

Table 2 Available PoE with AC Power Supply

Switch Models	Default Power Supply	Available PoE Power
12- and 24-port data (SFP)	C3KX-PWR-350WAC	–
24-port data		
48-port data		
24-port PoE+	C3KX-PWR-715WAC	495
48-port PoE+		462
48-port full PoE+	¹ C3KX-PWR-1100WAC	847

1. **Japan only:** To satisfy regulatory requirements, you must use the CAB-3KX-250VAC-JP power cord with the 1100-W power supply module.

Table 3 Available PoE with DC Power Supply

Switch Models	Power Supply	Available PoE Power
24-port PoE+	1	220 W
	2	660 W
48-port PoE+	1	187 W
	2	627 W

Table 1-4 Switch Power Supply Requirements for PoE, PoE+

PoE Option	24-Port Switch	48-Port Switch
PoE (up to 15.4 W per port)	(1) 715-W power supply (2) 440-W DC power supplies	(1) 1100-W power supply
PoE+ (up to 30 W per port)	(1) 1100-W power supply	(1) 1100-W power supply plus (1) 715-W power supply or (2) 1100-W power supplies

**Note**

A 48-port switch with one 715-W power supply provides up to 7.7 W of PoE to all ports.

The 350-W and 715-W AC power supply modules are autoranging units that support input voltages between 100 and 240 VAC. The 1100-W power supply module is an autoranging unit that supports input voltages between 115 and 240 VAC. The 440-W DC power supply module has dual input feeds (A and B) and supports input voltages between 36 and 72 VDC. The output voltage range is 51 to 57 V.

Each AC power supply module has a power cord for connection to an AC power outlet. The 1100-W and 715-W modules use a 16-AWG cord (only North America). All other modules use an 18-AWG cord. The DC power supply module must be wired to a DC power source.

**Note**

Only the DC power module is NEBS-compliant.

[Figure 1](#) to [Figure 4](#) show the power supply modules.

Figure 1 1100-W AC Power Supply

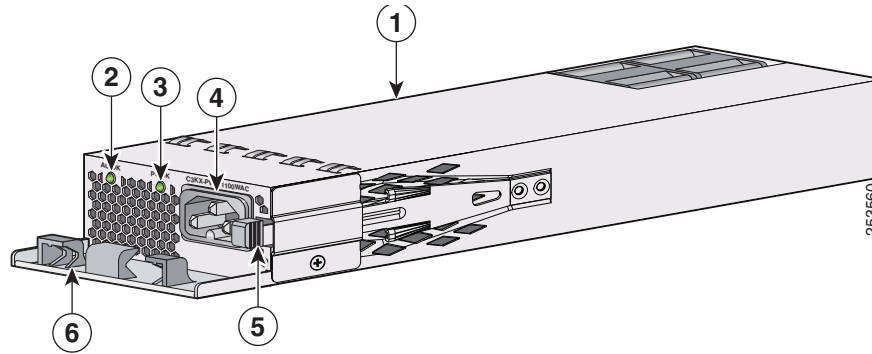

1	1100-W AC power supply module	4	AC power cord connector
2	AC OK LED	5	Release latch
3	PS OK LED	6	Power cord retainer

Figure 2 715-W AC Power Supply Module

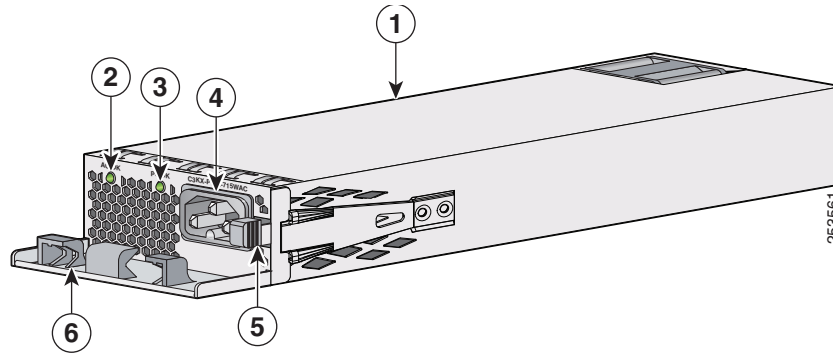

1	715-W AC power supply module	4	AC power cord connector
2	AC OK LED	5	Release latch
3	PS OK LED	6	Power cord retainer

Figure 3 350-W AC Power Supply Module

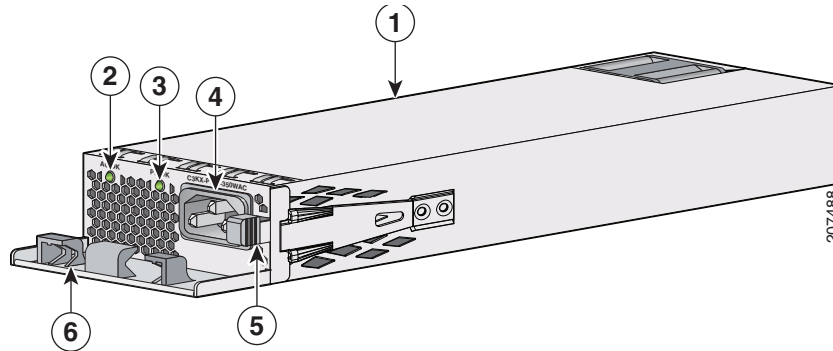

1	350-W AC power supply module	4	AC power cord connector
2	AC OK LED	5	Release latch
3	PS OK LED	6	Power cord retainer

Figure 4 440-W DC Power Supply Module

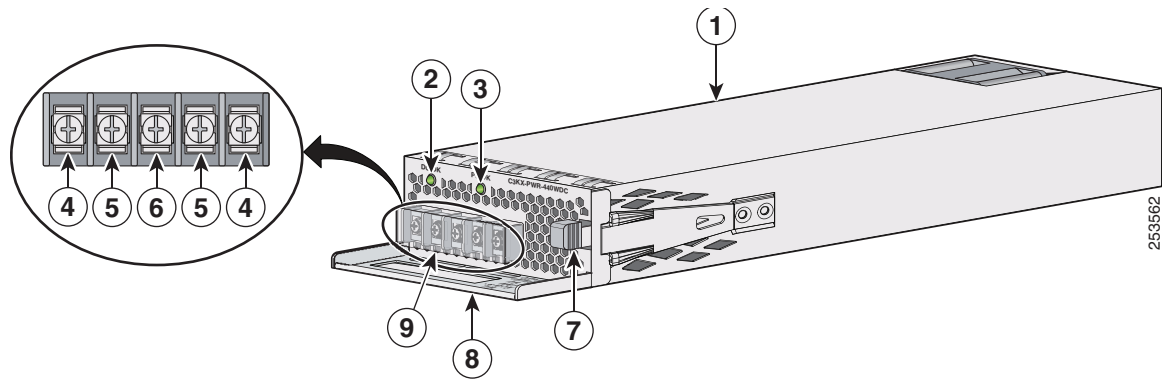

1	440-W DC power supply module	6	Grounding terminal
2	DC OK LED	7	Release latch
3	PS OK LED	8	Extraction handle
4	Input power terminals (positive polarity)	9	Terminal block safety cover
5	Input power terminals (negative polarity)		

If no power supply is installed in a power supply slot, install a power supply slot cover (Figure 5).

Figure 5 Power Supply Slot Cover

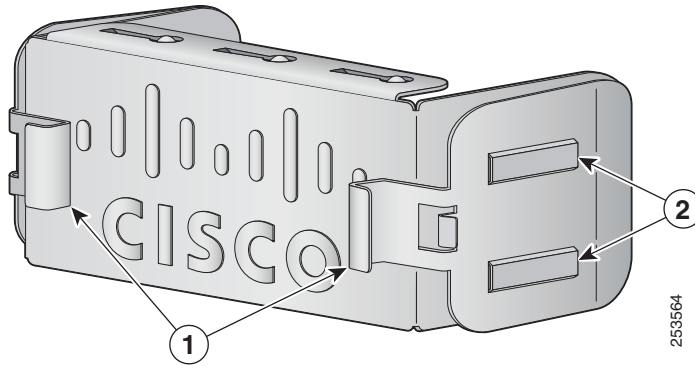

1	Release handles	2	Retainer clips
----------	-----------------	----------	----------------

The power supply modules have two status LEDs.

Table 5 Switch Power Supply Module LEDs

AC Power Supply Module LEDs			
AC OK	Description	PS OK	Description
Off (AC LED is off)	No AC input power.	Off	Output is disabled, or input is outside operating range.
Green	AC input power present.	Green	Power output to switch.
		Red	Output has failed.
DC Power Supply Module LEDs			
DC OK	Description	PS OK	Description
Off (DC LED is off)	No DC input power.	Off	Output is disabled, or input is outside operating range.
Green	DC input power present.	Green	Power output to switch.
		Red	Output has failed.

Installation Guidelines

Observe these guidelines when removing or installing a power supply module:

- Do not force the power supply into the slot. This can damage the switch pins if they are not aligned with the module.
- A power supply that is only partially connected to the switch can disrupt the system operation.
- Remove power from the power-supply module before removing or installing it.

- The power supply is hot-swappable. In some configurations, such as full PoE+ or power sharing mode, removing a power supply causes powered devices to shut down until the power budget matches the input power of a single power supply. To minimize network interruption, hot swap the power supply under these circumstances:
 - The switch is connected to an XPS-2200 and sufficient power is available.
 - The switch is in StackPower mode and sufficient power is available (Catalyst 3750-X only).
 - The switch is powered by other switches in a power stack, and no active backup is in progress.

For the switch commands for displaying the available power budget, see the *Catalyst 3750-X and 3560-X Software Configuration Guide*.

**Caution**

Do not operate the switch with one power-supply module slot empty. For proper chassis cooling, both module slots must have either a power supply module or a blank cover installed.

**Warning**

Blank faceplates and cover panels serve three important functions: they prevent exposure to hazardous voltages and currents inside the chassis; they contain electromagnetic interference (EMI) that might disrupt other equipment; and they direct the flow of cooling air through the chassis. Do not operate the system unless all cards, faceplates, front covers, and rear covers are in place.

Statement 1029

- Make sure that all power supply and fan modules are securely seated before moving the switch.

**Warning**

Do not reach into a vacant slot or chassis while you install or remove a module or a fan. Exposed circuitry could constitute an energy hazard. Statement 206

**Warning**

Only trained and qualified personnel should be allowed to install, replace, or service this equipment.

Statement 1030

Statement 371—Power Cable and AC Adapter

接続ケーブル、電源コード、ACアダプタ、バッテリーなどの部品は、必ず添付品または指定品をご使用ください。添付品・指定品以外の部品をご使用になると故障や動作不良、火災の原因となります。また、電気用品安全法により、当該法の認定（PSEとコードに表記）でなくUL認定（ULまたはCSAマークがコードに表記）の電源ケーブルは弊社が指定する製品以外の電気機器には使用できないためご注意ください。

Installing or Replacing an AC Power Supply

- Step 1** Turn off the power at its source, unless you are hot-swapping a power supply. If you are not replacing a power supply, go to Step 5.
- Step 2** Remove the power cord from the power cord retainer.
- Step 3** Remove the power cord from the power connector.
- Step 4** Press the release latch on the right side of the power supply module in, and slide the power supply out (Figure 6).

Caution

Do not leave the power-supply slot empty for more than 90 seconds while the switch is operating.

- Step 5** Install the new power supply into the power-supply slot, and gently push it into the slot. When correctly inserted, the 350-W and 715-W power supplies (excluding the power cord retainer) are flush with the switch rear panel. The 1100-W power-supply module extends 1.5 inches from the switch rear panel.
- If you are hot-swapping a power supply in a switch connected to an XPS-2200, the replacement power supply automatically provides power to the switch after about 3 seconds, leaving the XPS-2200 available to power other devices.

Figure 6 *Installing the AC Power Supply in the Switch*

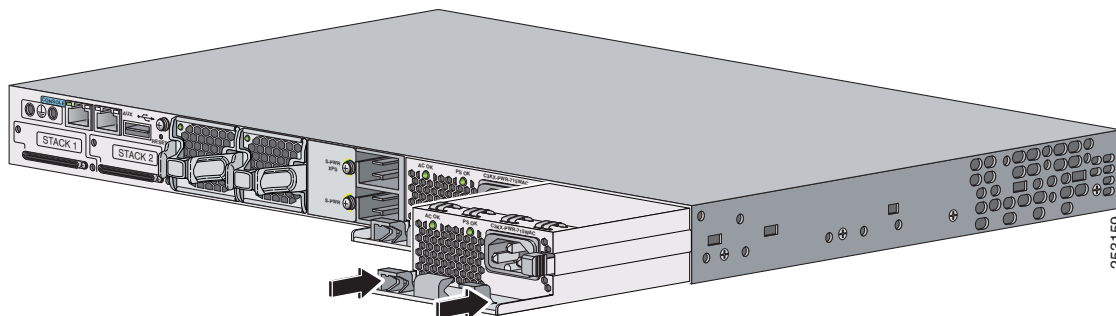

- Step 6** (Optional) Make a loop in the power cord, and thread it through the power cord retainer (Figure 7).

Figure 7 *AC Power Supply with Power Cord Retainer*

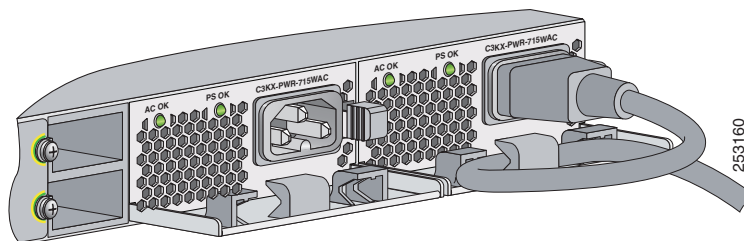

- Step 7** Connect the power cord to the power supply and to an AC power outlet. Turn on the power at the power source.
- Step 8** Confirm that the power supply *AC OK* and *PS OK* LEDs are green. See Table 5 for the LED descriptions.

Installing a DC Power Supply

- [Equipment That You Need](#), page 9
- [Grounding the Switch](#), page 10
- [Installing a DC Power Supply](#), page 9
- [Wiring the DC Input Power Source](#), page 12



Warning

An exposed wire lead from a DC-input power source can conduct harmful levels of electricity. Be sure that no exposed portion of the DC-input power source wire extends from the terminal block plug.

Statement 122



Warning

Before connecting or disconnecting ground or power wires to the chassis, ensure that power is removed from the DC circuit. To ensure that all power is OFF, locate the circuit breaker on the panel board that services the DC circuit, switch the circuit breaker to the OFF position, and tape the switch handle of the circuit breaker in the OFF position. Use a voltmeter to test for 0 (zero) voltage at the power terminals on the chassis. Statement 196



Warning

This product relies on the building's installation for short-circuit (overcurrent) protection. Ensure that the protective device is rated not greater than: 20 A. Statement 1005



Warning

A readily accessible two-poled disconnect device must be incorporated in the fixed wiring.

Statement 1022



Warning

Blank faceplates and cover panels serve three important functions: they prevent exposure to hazardous voltages and currents inside the chassis; they contain electromagnetic interference (EMI) that might disrupt other equipment; and they direct the flow of cooling air through the chassis. Do not operate the system unless all cards, faceplates, front covers, and rear covers are in place.

Statement 1029



Note

The grounding architecture of this product is DC-isolated (DC-I)

Equipment That You Need

- Ratcheting torque screwdriver with a number-2 Phillips head that exerts up to 15 pound-force inches (lbf-in.) of pressure
- Panduit crimping tool with optional controlled-cycle mechanism (model CT-720, CT-920, CT-920CH, CT-930, or CT-940CH)
- Wire-stripping tools
- 12-gauge copper ground wire (insulated or not) when using a single-ground connection
- 8-gauge copper ground wire (insulated or not) when using a dual-ground connection

- Ground lug screw and ring lug connector. For a dual-ground connection, use a dual-ground adaptor and dual lug connector.
- Four leads of 14-gauge copper wire
- Four fork-type terminals from the DC power supply accessory kit. The terminals must be the proper size for M3 screws in a Dinkle DT-35-B25-style terminal block

Grounding the Switch

Follow the grounding procedures at your site and observe these warnings:



Warning

This equipment must be grounded. Never defeat the ground conductor or operate the equipment in the absence of a suitably installed ground conductor. Contact the appropriate electrical inspection authority or an electrician if you are uncertain that suitable grounding is available. Statement 1024



Warning

When installing or replacing the unit, the ground connection must always be made first and disconnected last. Statement 1046



Caution

Follow the grounding procedure instructions, and use a UL-listed lug.

Follow these steps to install either a single-ground lug or a dual-ground lug on the switch. Make sure to follow any grounding requirements at your site.

- Step 1** Use the ground lug screw and the lug ring for a single-ground connection. Use the dual-ground adaptor and dual-hole lug for a dual-ground connection.
- Step 2** Strip the 12-gauge or 8-gauge ground wire to 0.5 inch (12.7 mm) \pm 0.02 inch (0.5 mm) (Figure 8). Stripping more than the recommended amount of wire can leave exposed wire from the connector. Use 12-gauge copper ground wire for the single-ground connection. Use 8-gauge copper ground wire for the dual-ground connection.

Figure 8 Stripping the Ground Wire

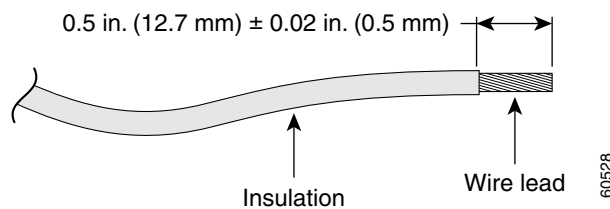

- Step 3** Slide the open end of the ground lug over the exposed area of the wire.
- Step 4** Using a Panduit crimping tool, crimp the ground lug to the wire (Figure 9).

Figure 9 *Crimping the Ground Lug*

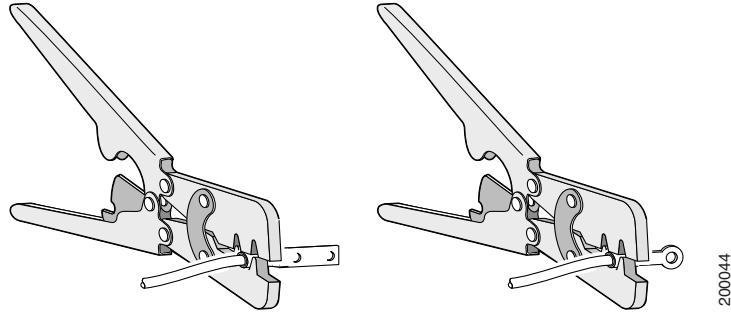

- Step 5** Use the ground screw to attach the single-ground lug to the switch rear panel. Use two ground screws to attach the dual-hole lug to the switch rear panel (Figure 10).
- Step 6** Using a ratcheting torque screwdriver, torque the ground-lug screws to 60 lbf-in. (960 ozf-in.).
- Step 7** Connect the other end of the grounding wire to an appropriate grounding point at your site or to the rack.

Figure 10 *Attaching the Ground Lug and Wire Assembly*

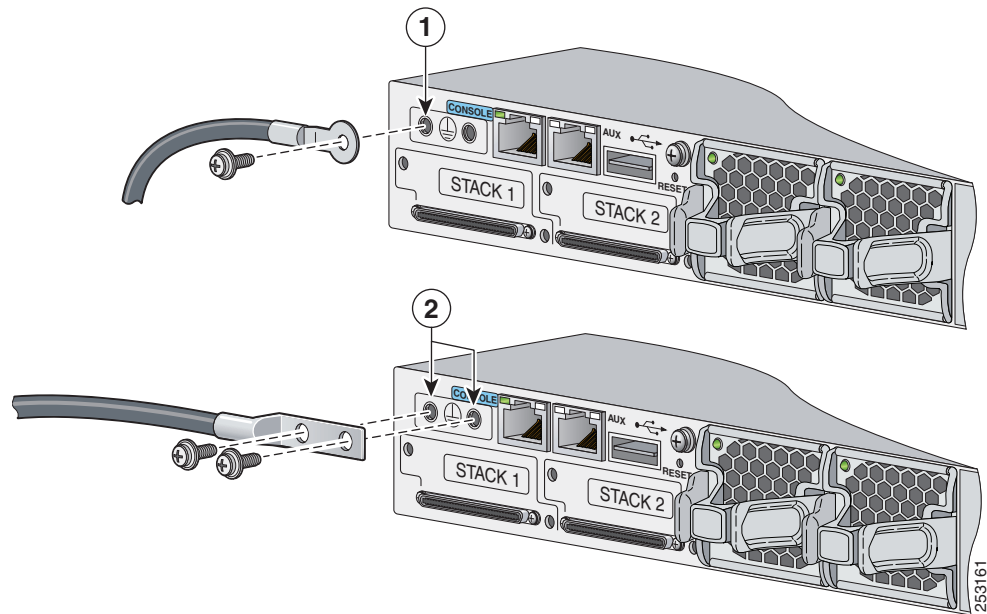

1	Single-ground screw and lug ring	2	Dual-ground adaptor and dual-hole lug
----------	----------------------------------	----------	---------------------------------------

Installing the DC Power Supply in the Switch

See the “[Installation Guidelines](#)” section on page 6.

-
- Step 1** Turn off DC power. To ensure that power is off, change the circuit breakers to the OFF position, and tape the circuit-breaker switches in the OFF position.
 - Step 2** Remove the plastic safety cover from the power supply terminal blocks ([Figure 4](#)). If you are not replacing a DC power supply, go to [Step 5](#).
 - Step 3** Use a number-2 Phillips screwdriver to remove the DC-input power wires from the power terminals.
 - Step 4** Press the release latch at the right side of the power supply module inward, and pull the power supply out.
 - Step 5** Install the power supply in the power-supply slot, and gently push it into the slot ([Figure 11](#)). When correctly inserted, the DC power supply (excluding the extraction handle) is flush with the switch rear panel.

Figure 11 Inserting the DC Power Supply in the Switch

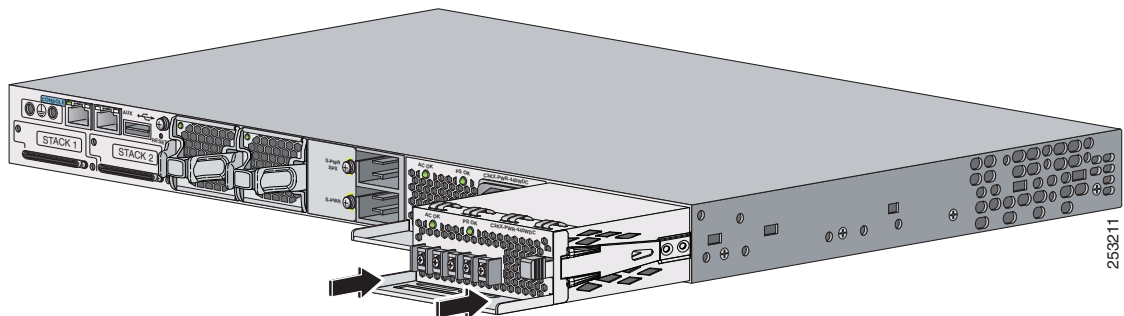

-
- Step 6** Connect the input power as described in the “[Wiring the DC Input Power Source](#)” section.
-

Wiring the DC Input Power Source

-
- Step 1** Using a wire-stripping tool, strip each of the four wires from the DC-input power source to the appropriate length for the terminals.



Warning

Use copper conductors only. Statement 1025

-
- Step 2** Using a Panduit crimping tool, crimp the fork-type terminals to the copper conductor, 90C, 14-AWG DC power input wires.
 - Step 3** Connect the DC-input power terminals to the terminal blocks. See [Figure 12](#) or [Figure 13](#). Make sure to match the polarity (negative to negative, positive to positive) when connecting the wires to the terminal blocks. Connect the ground wire to a grounded metal rack or to earth ground if the switch is not in a grounded rack.

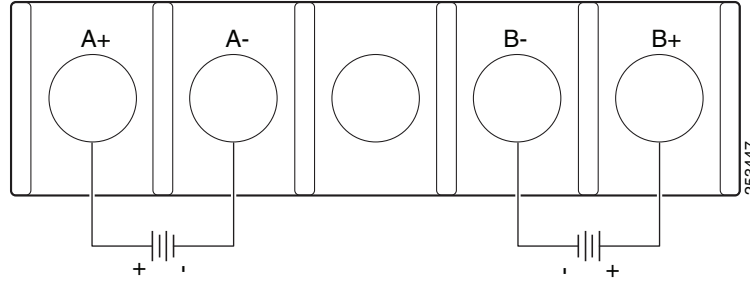
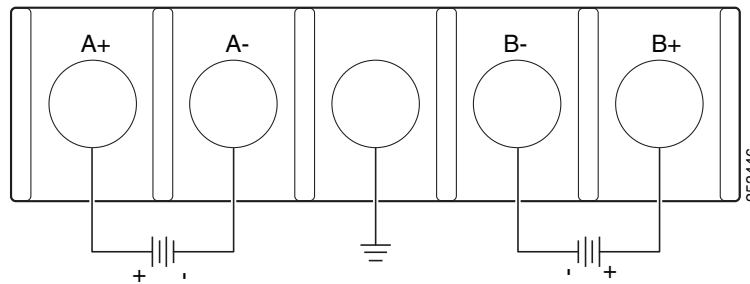
Figure 12 DC Source A Isolated From Source B with No Common Ground**Figure 13** DC Source A and Source B Connections with Common Ground

- Step 4** Torque all terminal block screws to 11 lbf-in.
- Step 5** Replace the terminal block safety cover.
- Step 6** Move the DC power source circuit-breakers to the ON position.
- Step 7** Confirm that the power-supply *DC OK* and *PS OK* LEDs are green. See [Table 5](#) for a description of the module LEDs.

Finding the Power Supply Module Serial Number

If you contact Cisco Technical Assistance regarding a power supply module, you need to know the serial number. See [Figure 14](#) to [Figure 16](#) to find the serial number.

Figure 14 1100-W AC Power Supply Serial Number

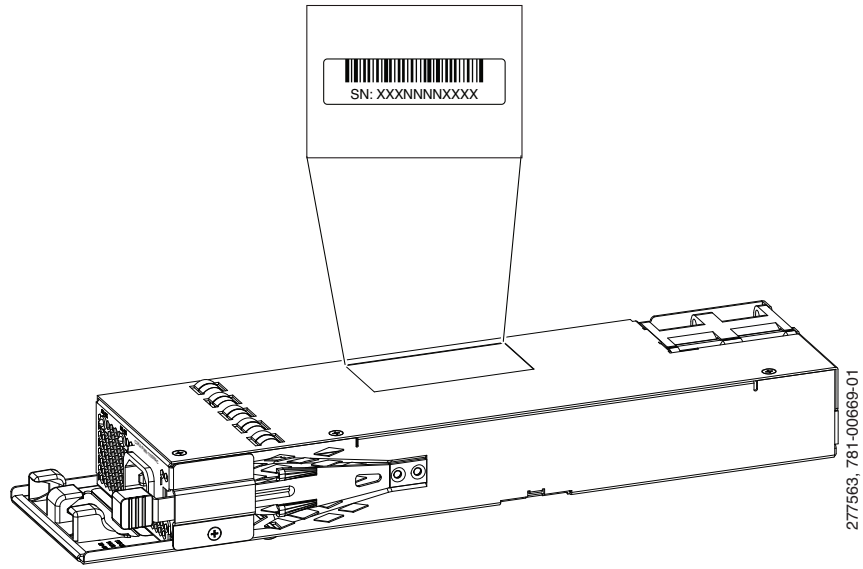

Figure 15 715-W and 350-W AC Power Supply Module Serial Number

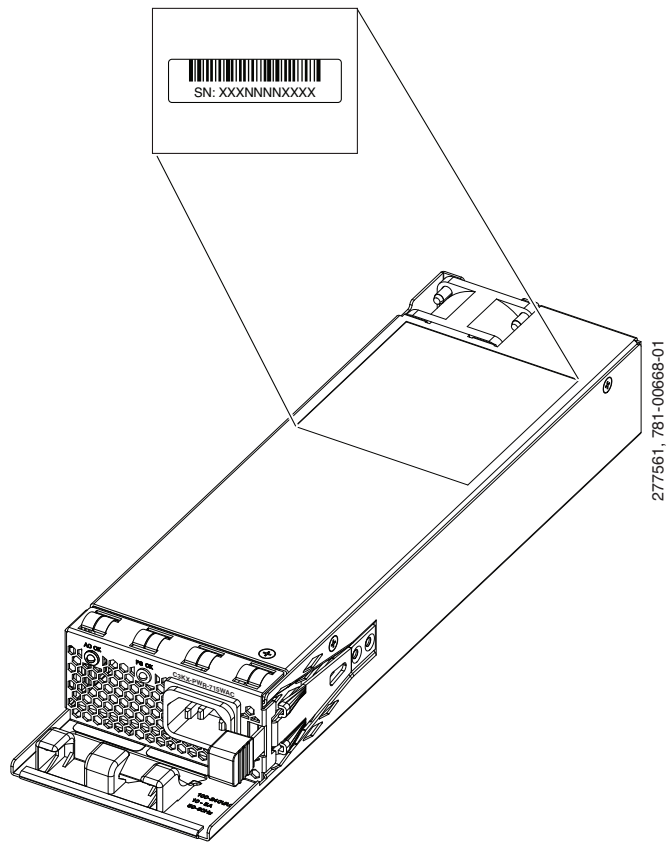
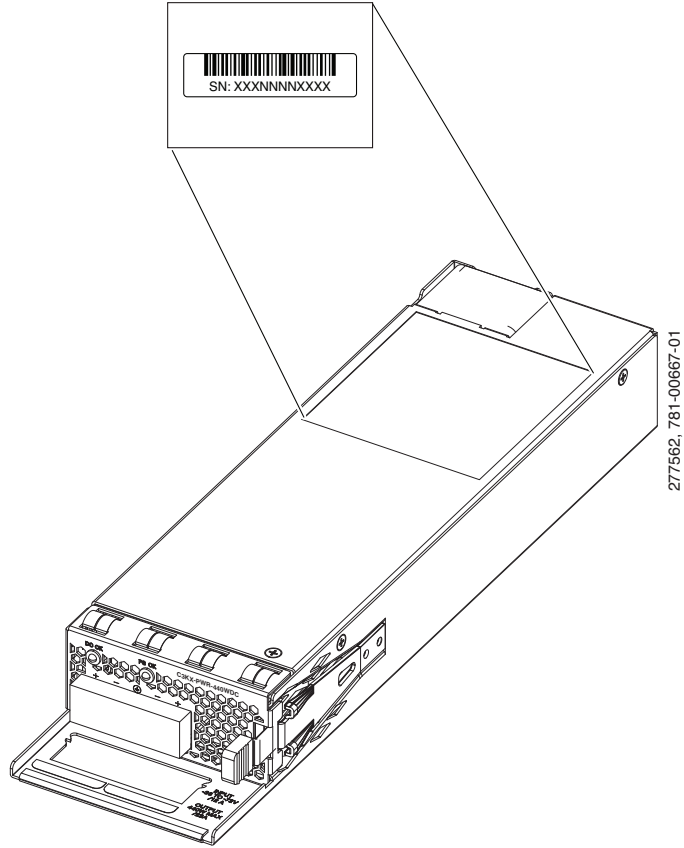

Figure 16 **440-W DC Power Supply Module Serial Number**



Technical Specifications

Table 6 Power Supply Module Environmental and Physical Specifications

Environmental Ranges	
Operating temperature	23 to 113° F (–5 to 45° C)
Storage temperature	–40 to 158° F (–40 to 70° C)
Relative humidity	10 to 95% (noncondensing)
Altitude	Up to 10,000 ft (3049 m)
Physical Specifications	
Weight	
C3KX-PWR-1100WAC	3 lb (1.4 kg)
C3KX-PWR-715WAC	2.8 lb (1.3 kg)
C3KX-PWR-350WAC	2.7 lb (1.2 kg)
C3KX-PWR-440WDC	3.5 lb (1.6 kg)
Dimensions (H x D x W)	
C3KX-PWR-1100WAC	1.38 x 11.72 x 3.25 in. (3.5 x 29.8 x 8.3 cm)
C3KX-PWR-715WAC	1.38 x 10.22 x 3.25 in. (3.5 x 26 x 8.3 cm)
C3KX-PWR-350WAC	1.38 x 10.22 x 3.25 in. (3.5 x 26 x 8.3 cm)
C3KX-PWR-440WDC	Note 1.38 x 10.22 x 3.25 in. (3.5 x 26 x 8.3 cm)
	Dimensions shown exclude the attached power cord retainer (AC power supplies) or the extraction handle (DC power supplies), which measures 1.55 in. (3.9 cm).

Table 7 AC Power Supply Module Power Specifications

Power Specifications	
Maximum output power	C3KX-PWR-1100WAC: 1100 W C3KX-PWR-715WAC: 715 W C3KX-PWR-350WAC: 350 W
Input voltage range and frequency	C3KX-PWR-1100WAC: 1100-W, 115 to 240 VAC (autoranging) 50 to 60 Hz C3KX-PWR-715WAC: 715 W, 100 to 240 VAC (autoranging), 50 to 60 Hz C3KX-PWR-350WAC: 350 W, 100 to 240 VAC (autoranging), 50 to 60 Hz
Input current	C3KX-PWR-1100WAC: 12–6 A C3KX-PWR-715WAC: 10–5 A C3KX-PWR-350WAC: 4–2 A
Output ratings	C3KX-PWR-1100WAC: –56 V@19.64 A C3KX-PWR-715WAC: –56 V@12.8 A C3KX-PWR-350WAC: –56 V@6.25 A
Total input BTU ¹	C3KX-PWR-1100WAC: 4263 Btus per hour, 1250 W C3KX-PWR-715WAC: 2742 Btus per hour, 804 W C3KX-PWR-350WAC: 1357 Btus per hour, 398 W
Total output BTU ¹	C3KX-PWR-1100WAC: 3751 Btus per hour, 1100W C3KX-PWR-715WAC: 2438 Btus per hour, 765 W C3KX-PWR-350WAC: 1194 Btus per hour, 350 W

1. The total input and total output BTU ratings refer to input power to the power supply and output power to the switch. The BTU ratings are based on 100 VAC for the 350-W and 715-W power supplies and 115 VAC for the 1100-W power supply.

Table 8 Power Specifications for DC-Power 12-, 24-, and 48-Port Switches

Power Specifications	
Maximum output power	C3KX-PWR-440WDC: 440 W
Input current	C3KX-PWR-440WDC: 16 – 8 A
DC input voltage	C3KX-PWR-440WDC: –36 to –72 VDC
Output ratings	C3KX-PWR-440WDC: –56 V@7.86 A
Voltage range domestic	C3KX-PWR-440WDC: –36 VDC (minimum) –48 VDC (nominal), –72 VDC (maximum)
Voltage range international	C3KX-PWR-440WDC: –36 VDC (minimum) –60 VDC (nominal), –72 VDC (maximum)
Total input BTU ¹	C3KX-PWR-440WDC: 1841 Btus per hour, 540 W
Total output BTU ¹	C3KX-PWR-440WDC: 1502 Btus per hour, 440 W
Wire gauge for ground connection	C3KX-PWR-440WDC: 12 AWG or 8 AWG
Branch circuit protection	C3KX-PWR-440WDC: 20 A

1. The total input and total output BTU ratings refer to input power to the power supply and output power to the switch. The BTU ratings are based on –36 VDC.

Table 9 Standards and Certifications

Description	Specification
Safety certifications	UL 60950-1 C-UL to CAN/CSA 22.2 No.60950-1 TUV/GS to EN 60950-1 CB to IEC 60950-1 with all country deviations CE marking CCC (China compulsory certification)
Electromagnetic compatibility certifications	FCC Part 15 Class A EN55022 Class A (CISPR22) EN55024 (CISPR24) CE VCCI Class A AS/NZS CISPR22 Class A KCC China EMC certifications
Environmental	Reduction of Hazardous Substances (ROHS) 5
Noise specifications	Office product spec: 48 dBA at 86° F (30° C)
Telco	CLEI code

Related Publications

These documents are on Cisco.com:

http://www.cisco.com/en/US/products/ps10745/tsd_products_support_general_information.html

- *Catalyst 3750-X and 3560-X Switch Getting Started Guide*
- *Catalyst 3750-X and 3560-X Switch Hardware Installation Guide*
- *Regulatory Compliance and Safety Information for the Catalyst 3750-X and 3560-X Switch*
- *Installation Notes for the Catalyst 3750-X, Catalyst 3560-X Switch Power Supply Modules*
- *Installation Notes for the Catalyst 3750-X and 3560-X Switch Fan Module*
- *Installation Notes for the Catalyst 3750-X and 3560-X Switch Network Modules*
- *Release Notes for the Catalyst 3750-X and 3560-X Switch*
- *Catalyst 3750-X and 3560-X Switch Software Configuration Guide*
- *Catalyst 3750-X and 3560-X Switch Command Reference*
- *Catalyst 3750-X, 3750-E, 3560-X, and 3560-E Switch System Message Guide*
- *Cisco IOS Software Installation Document*

Information about Cisco SFP and SFP+ modules is available from this Cisco.com site:

http://www.cisco.com/en/US/products/hw/modules/ps5455/prod_installation_guides_list.html

SFP compatibility matrix documents are available from this Cisco.com site:

http://www.cisco.com/en/US/products/hw/modules/ps5455/products_device_support_tables_list.html

Obtaining Documentation and Submitting a Service Request

For information on obtaining documentation, submitting a service request, and gathering additional information, see the monthly *What's New in Cisco Product Documentation*, which also lists all new and revised Cisco technical documentation, at:

<http://www.cisco.com/en/US/docs/general/whatsnew/whatsnew.html>

Subscribe to the *What's New in Cisco Product Documentation* as a Really Simple Syndication (RSS) feed and set content to be delivered directly to your desktop using a reader application. The RSS feeds are a free service and Cisco currently supports RSS Version 2.0.

This document is to be used in conjunction with the documents listed in the “[Related Publications](#)” section.

Cisco and the Cisco logo are trademarks or registered trademarks of Cisco and/or its affiliates in the U.S. and other countries. To view a list of Cisco trademarks, go to this URL: www.cisco.com/go/trademarks. Third-party trademarks mentioned are the property of their respective owners. The use of the word partner does not imply a partnership relationship between Cisco and any other company. (1110R)

© 2010 Cisco Systems, Inc. All rights reserved.

