



Configuring VLANs

This chapter describes how to configure normal-range VLANs (VLAN IDs 1 to 1005) and extended-range VLANs (VLAN IDs 1006 to 4094). It includes information about VLAN modes and the VLAN Membership Policy Server (VMPS).



Note

For complete syntax and usage information for the commands used in this chapter, refer to the command reference for this release.

The chapter includes these sections:

- [Understanding VLANs, page 10-1](#)
- [Configuring Normal-Range VLANs, page 10-4](#)
- [Configuring Extended-Range VLANs, page 10-12](#)
- [Displaying VLANs, page 10-15](#)
- [Configuring VLAN Trunks, page 10-16](#)
- [Configuring VMPS, page 10-26](#)

Understanding VLANs

A VLAN is a switched network that is logically segmented by function, project team, or application, without regard to the physical locations of the users. VLANs have the same attributes as physical LANs, but you can group end stations even if they are not physically located on the same LAN segment. Any switch port can belong to a VLAN, and unicast, broadcast, and multicast packets are forwarded and flooded only to end stations in the VLAN. Each VLAN is considered a logical network, and packets destined for stations that do not belong to the VLAN must be forwarded through a router or bridge as shown in [Figure 10-1](#). Because a VLAN is considered a separate logical network, it contains its own bridge Management Information Base (MIB) information and can support its own implementation of spanning tree. See [Chapter 14, “Configuring STP”](#) and [Chapter 15, “Configuring RSTP and MSTP.”](#)



Note

Before you create VLANs, you must decide whether to use VLAN Trunking Protocol (VTP) to maintain global VLAN configuration for your network. For more information on VTP, see [Chapter 11, “Configuring VTP.”](#)

Figure 10-1 shows an example of VLANs segmented into logically defined networks.

Figure 10-1 VLANs as Logically Defined Networks

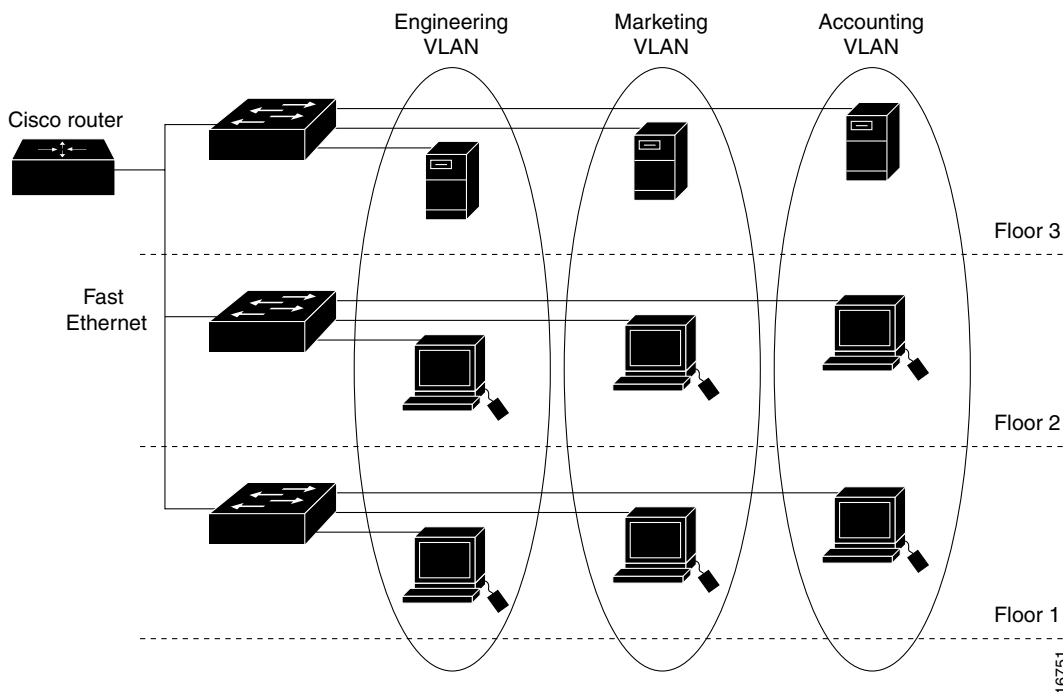

VLANs are often associated with IP subnetworks. For example, all the end stations in a particular IP subnet belong to the same VLAN. Interface VLAN membership on the switch is assigned manually on an interface-by-interface basis. When you assign switch interfaces to VLANs by using this method, it is known as interface-based, or static, VLAN membership.

Traffic between VLANs must be routed or fallback bridged. A Catalyst 3550 switch can route traffic between VLANs by using switch virtual interfaces (SVIs). An SVI must be explicitly configured and assigned an IP address to route traffic between VLANs. For more information, see the “Switch Virtual Interfaces” section on page 9-4 and the “Configuring Layer 3 Interfaces” section on page 9-17.

Supported VLANs

The Catalyst 3550 switch supports 1005 VLANs in VTP client, server, and transparent modes. VLANs are identified with a number from 1 to 4094. VLAN IDs 1002 through 1005 are reserved for Token Ring and FDDI VLANs. VTP only learns normal-range VLANs, with VLAN IDs 1 to 1005; VLAN IDs greater than 1005 are extended-range VLANs and are not stored in the VLAN database. The switch must be in VTP transparent mode when you create VLAN IDs from 1006 to 4094.

The switch supports per-VLAN spanning tree (PVST) with a maximum of 128 spanning-tree instances. One spanning-tree instance is allowed per VLAN. See the “Normal-Range VLAN Configuration Guidelines” section on page 10-5 for more information about the number of spanning-tree instances and the number of VLANs. The switch supports both Inter-Switch Link (ISL) and IEEE 802.1Q trunking methods for sending VLAN traffic over Ethernet ports.

VLAN Port Membership Modes

You configure a port to belong to a VLAN by assigning a membership mode that determines the kind of traffic the port carries and the number of VLANs to which it can belong. [Table 10-1](#) lists the membership modes and membership and VTP characteristics.

Table 10-1 Port Membership Modes

Membership Mode	VLAN Membership Characteristics	VTP Characteristics
Static-access	A static-access port can belong to one VLAN and is manually assigned to that VLAN. For more information, see the “Assigning Static-Access Ports to a VLAN” section on page 10-11.	VTP is not required. If you do not want VTP to globally propagate information, set the VTP mode to transparent to disable VTP. To participate in VTP, there must be at least one trunk port on the switch connected to a trunk port of a second switch.
Trunk (ISL or IEEE 802.1Q)	A trunk port is a member of all VLANs by default, including extended-range VLANs, but membership can be limited by configuring the allowed-VLAN list. You can also modify the pruning-eligible list to block flooded traffic to VLANs on trunk ports that are included in the list. For information about configuring trunk ports, see the “Configuring an Ethernet Interface as a Trunk Port” section on page 10-19.	VTP is recommended but not required. VTP maintains VLAN configuration consistency by managing the addition, deletion, and renaming of VLANs on a network-wide basis. VTP exchanges VLAN configuration messages with other switches over trunk links.
Dynamic access	A dynamic-access port can belong to one normal-range VLAN (VLAN ID 1 to 1005) and is dynamically assigned by a VMPS. The VMPS can be a Catalyst 5000 or Catalyst 6000 series switch, for example, but never a Catalyst 3550 switch. You can have dynamic-access ports and trunk ports on the same switch, but you must connect the dynamic-access port to an end station and not to another switch. For configuration information, see the “Configuring Dynamic Access Ports on VMPS Clients” section on page 10-31.	VTP is required. Configure the VMPS and the client with the same VTP domain name. You can change the reconfirmation interval and retry count on the VMPS client switch.
Tunnel (dot1q-tunnel)	Tunnel ports are used for 802.1Q tunneling to maintain customer VLAN integrity across a service provider network. You configure a tunnel port on an edge switch in the service provider network and connect it to an 802.1Q trunk port on a customer interface, creating an asymmetric link. A tunnel port belongs to a single VLAN that is dedicated to tunneling. For more information about tunnel ports, see Chapter 13 , “Configuring 802.1Q and Layer 2 Protocol Tunneling.”	VTP is not required. You manually assign the tunnel port to a VLAN by using the switchport access vlan interface configuration command.

For more detailed definitions of the modes and their functions, see [Table 10-4](#) on page 10-17.

When a port belongs to a VLAN, the switch learns and manages the addresses associated with the port on a per-VLAN basis. For more information, see the [“Managing the MAC Address Table”](#) section on page 7-54.

Configuring Normal-Range VLANs

Normal-range VLANs are VLANs with VLAN IDs 1 to 1005. If the switch is in VTP server or transparent mode, you can add, modify or remove configurations for VLANs 2 to 1001 in the VLAN database. (VLAN IDs 1 and 1002 to 1005 are automatically created and cannot be removed.)



Note

When the switch is in VTP transparent mode, you can also create extended-range VLANs (VLANs with IDs from 1006 to 4094), but these VLANs are not saved in the VLAN database. See the “[Configuring Extended-Range VLANs](#)” section on page 10-12.

Configurations for VLAN IDs 1 to 1005 are written to the file *vlan.dat* (VLAN database), and you can display them by entering the **show vlan** privileged EXEC command. The *vlan.dat* file is stored in nonvolatile RAM (NVRAM).



Caution

You can cause inconsistency in the VLAN database if you attempt to manually delete the *vlan.dat* file. If you want to modify the VLAN configuration, use the commands described in these sections and in the command reference for this release. To change the VTP configuration, see [Chapter 11, “Configuring VTP.”](#)

You use the interface configuration mode to define the port membership mode and to add and remove ports from VLANs. The results of these commands are written to the running-configuration file, and you can display the file by entering the **show running-config** privileged EXEC command.

You can set these parameters when you create a new normal-range VLAN or modify an existing VLAN in the VLAN database:

- VLAN ID
- VLAN name
- VLAN type (Ethernet, Fiber Distributed Data Interface [FDDI], FDDI network entity title [NET], TrBRF, or TrCRF, Token Ring, Token Ring-Net)
- VLAN state (active or suspended)
- Maximum transmission unit (MTU) for the VLAN
- Security Association Identifier (SAID)
- Bridge identification number for TrBRF VLANs
- Ring number for FDDI and TrCRF VLANs
- Parent VLAN number for TrCRF VLANs
- Spanning Tree Protocol (STP) type for TrCRF VLANs
- VLAN number to use when translating from one VLAN type to another



Note

This section does not provide configuration details for most of these parameters. For complete information on the commands and parameters that control VLAN configuration, refer to the command reference for this release.

This section includes information about these topics about normal-range VLANs:

- [Token Ring VLANs, page 10-5](#)
- [Normal-Range VLAN Configuration Guidelines, page 10-5](#)
- [VLAN Configuration Mode Options, page 10-6](#)
- [Saving VLAN Configuration, page 10-7](#)
- [Default Ethernet VLAN Configuration, page 10-8](#)
- [Creating or Modifying an Ethernet VLAN, page 10-8](#)
- [Deleting a VLAN, page 10-10](#)
- [Assigning Static-Access Ports to a VLAN, page 10-11](#)

Token Ring VLANs

Although the switch does not support Token Ring connections, a remote device such as a Catalyst 5000 series switch with Token Ring connections could be managed from one of the supported switches. Switches running VTP version 2 advertise information about these Token Ring VLANs:

- Token Ring TrBRF VLANs
- Token Ring TrCRF VLANs

For more information on configuring Token Ring VLANs, refer to the *Catalyst 5000 Series Software Configuration Guide*.

Normal-Range VLAN Configuration Guidelines

Follow these guidelines when creating and modifying normal-range VLANs in your network:

- The switch supports 1005 VLANs in VTP client, server, and transparent modes. Normal-range VLANs are identified with a number between 1 and 1001. VLAN numbers 1002 through 1005 are reserved for Token Ring and FDDI VLANs.
- VLAN configuration for VLANs 1 to 1005 are always saved in the VLAN database. If VTP mode is transparent, VTP and VLAN configuration is also saved in the switch running configuration file.
- The switch also supports VLAN IDs 1006 through 4094 in VTP transparent mode (VTP disabled). These are extended-range VLANs and configuration options are limited. Extended-range VLANs are not saved in the VLAN database. See the [“Configuring Extended-Range VLANs” section on page 10-12](#).
- Before you can create a VLAN, the switch must be in VTP server mode or VTP transparent mode. If the switch is a VTP server, you must define a VTP domain or VTP will not function.
- The switch does not support Token Ring or FDDI media. The switch does not forward FDDI, FDDI-Net, TrCRF, or TrBRF traffic, but it does propagate the VLAN configuration through VTP.
- The switch supports 128 spanning-tree instances. If a switch has more active VLANs than supported spanning-tree instances, spanning tree can be enabled on 128 VLANs and is disabled on the remaining VLANs. If you have already used all available spanning-tree instances on a switch, adding another VLAN anywhere in the VTP domain creates a VLAN on that switch that is not running spanning-tree. If you have the default allowed list on the trunk ports of that switch (which is to allow all VLANs), the new VLAN is carried on all trunk ports. Depending on the topology of the network, this could create a loop in the new VLAN that would not be broken, particularly if there

are several adjacent switches that all have run out of spanning-tree instances. You can prevent this possibility by setting allowed lists on the trunk ports of switches that have used up their allocation of spanning-tree instances.

If the number of VLANs on the switch exceeds the number of supported spanning tree instances, we recommend that you configure the IEEE 802.1S Multiple STP (MSTP) on your switch to map multiple VLANs to a single STP instance. For more information about MSTP, see [Chapter 15, “Configuring RSTP and MSTP.”](#)

VLAN Configuration Mode Options

You can configure normal-range VLANs (with VLAN IDs 1 to 1005) by using these two configuration modes:

- [VLAN Configuration in config-vlan Mode, page 10-6](#)

You access config-vlan mode by entering the **vlan** *vlan-id* global configuration command.

- [VLAN Configuration in VLAN Configuration Mode, page 10-6](#)

You access VLAN configuration mode by entering the **vlan database** privileged EXEC command.

VLAN Configuration in config-vlan Mode

To access config-vlan mode, enter the **vlan** global configuration command with a VLAN ID. Enter a new VLAN ID to create a VLAN or with an existing VLAN ID to modify the VLAN. You can use the default VLAN configuration ([Table 10-2](#)) or enter multiple commands to configure the VLAN. For more information about commands available in this mode, refer to the **vlan** global configuration command description in the command reference for this release. When you have finished the configuration, you must exit config-vlan mode for the configuration to take effect. To display the VLAN configuration, enter the **show vlan** privileged EXEC command.

You must use this config-vlan mode when creating extended-range VLANs (VLAN IDs greater than 1005). See the [“Configuring Extended-Range VLANs”](#) section on page 10-12.

VLAN Configuration in VLAN Configuration Mode

To access VLAN configuration mode, enter the **vlan database** privileged EXEC command. Then enter the **vlan** command with a new VLAN ID to create a VLAN or with an existing VLAN ID to modify the VLAN. You can use the default VLAN configuration ([Table 10-2](#)) or enter multiple commands to configure the VLAN. For more information about keywords available in this mode, refer to the **vlan** VLAN configuration command description in the command reference for this release. When you have finished the configuration, you must enter **apply** or **exit** for the configuration to take effect. When you enter the **exit** command, it applies all commands and updates the VLAN database. VTP messages are sent to other switches in the VTP domain, and the privileged EXEC mode prompt appears.

Saving VLAN Configuration

The configurations of VLAN IDs 1 to 1005 are always saved in the VLAN database (vlan.dat file). If VTP mode is transparent, they are also saved in the switch running configuration file and you can enter the **copy running-config startup-config** privileged EXEC command to save the configuration in the startup configuration file. You can use the **show running-config vlan** privileged EXEC command to display the switch running configuration file. To display the VLAN configuration, enter the **show vlan** privileged EXEC command.

When you save VLAN and VTP information (including extended-range VLAN configuration information) in the startup configuration file and reboot the switch, the switch configuration is determined as follows:

- If the VTP mode is transparent in the startup configuration, and the VLAN database and the VTP domain name from the VLAN database matches that in the startup configuration file, the VLAN database is ignored (cleared), and the VTP and VLAN configurations in the startup configuration file are used. The VLAN database revision number remains unchanged in the VLAN database.
- If the VTP mode or domain name in the startup configuration does not match the VLAN database, the domain name and VTP mode and configuration for the first 1005 VLANs use the VLAN database information.
- If VTP mode is server, the domain name and VLAN configuration for the first 1005 VLANs use the VLAN database information.
- If the switch is running IOS Release 12.1(9)EA1 or later and you use an older startup configuration file to boot up the switch, the configuration file does not contain VTP or VLAN information, and the switch uses the VLAN database configurations.
- If the switch is running an IOS release earlier than 12.1(9)EA1 and you use a startup configuration file from IOS Release 12.1(9)EA1 or later to boot up the switch, the image on the switch does not recognize the VLAN and VTP configurations in the startup configuration file, so the switch uses the VLAN database configuration.

**Caution**

If the VLAN database configuration is used at startup and the startup configuration file contains extended-range VLAN configuration, this information is lost when the system boots up.

Default Ethernet VLAN Configuration

Table 10-2 shows the default configuration for Ethernet VLANs.

Note

The switch supports Ethernet interfaces exclusively. Because FDDI and Token Ring VLANs are not locally supported, you only configure FDDI and Token Ring media-specific characteristics for VTP global advertisements to other switches.

Table 10-2 Ethernet VLAN Defaults and Ranges

Parameter	Default	Range
VLAN ID	1	1 to 4094. Note Extended-range VLANs (VLAN IDs 1006 to 4094) are not saved in the VLAN database.
VLAN name	VLANxxxx, where xxxx represents four numeric digits (including leading zeros) equal to the VLAN ID number	No range
802.10 SAID	100001 (100000 plus the VLAN ID)	1–4294967294
MTU size	1500	1500–18190
Translational bridge 1	0	0–1005
Translational bridge 2	0	0–1005
VLAN state	active	active, suspend

Creating or Modifying an Ethernet VLAN

Each Ethernet VLAN in the VLAN database has a unique, 4-digit ID that can be a number from 1 to 1001. VLAN IDs 1002 to 1005 are reserved for Token Ring and FDDI VLANs. To create a normal-range VLAN to be added to the VLAN database, assign a number and name to the VLAN.

Note

When the switch is in VTP transparent mode, you can assign VLAN IDs greater than 1006, but they are not added to the VLAN database. See the “[Configuring Extended-Range VLANs](#)” section on [page 10-12](#).

For the list of default parameters that are assigned when you add a VLAN, see the “[Configuring Normal-Range VLANs](#)” section on [page 10-4](#).

Beginning in privileged EXEC mode, follow these steps to use config-vlan mode to create or modify an Ethernet VLAN:

	Command	Purpose
Step 1	configure terminal	Enter global configuration mode.
Step 2	vlan <i>vlan-id</i>	Enter a VLAN ID, and enter config-vlan mode. Enter a new VLAN ID to create a VLAN, or enter an existing VLAN ID to modify a VLAN. Note The available VLAN ID range for this command is 1 to 4094; do not enter leading zeros. For information about adding VLAN IDs greater than 1005 (extended-range VLANs), see the “Configuring Extended-Range VLANs” section on page 10-12.
Step 3	name <i>vlan-name</i>	(Optional) Enter a name for the VLAN. If no name is entered for the VLAN, the default is to append the <i>vlan-id</i> with leading zeros to the word VLAN. For example, VLAN0004 is a default VLAN name for VLAN 4.
Step 4	mtu <i>mtu-size</i>	(Optional) Change the MTU size (or other VLAN characteristic).
Step 5	end	Return to privileged EXEC mode.
Step 6	show vlan { name <i>vlan-name</i> id <i>vlan-id</i> }	Verify your entries.
Step 7	copy running-config startup config	(Optional) If the switch is in VTP transparent mode, the VLAN configuration is saved in the running configuration file as well as in the VLAN database. This saves the configuration in the switch startup configuration file.

To return the VLAN name to the default settings, use the **no vlan name** or **no vlan mtu** config-vlan commands.

This example shows how to use config-vlan mode to create Ethernet VLAN 20, name it *test20*, and add it to the VLAN database:

```
Switch# configure terminal
Switch(config)# vlan 20
Switch(config-vlan)# name test20
Switch(config-vlan)# end
```

Beginning in privileged EXEC mode, follow these steps to use VLAN configuration mode to create or modify an Ethernet VLAN:

	Command	Purpose
Step 1	vlan database	Enter VLAN configuration mode.
Step 2	vlan <i>vlan-id</i> name <i>vlan-name</i>	Add an Ethernet VLAN by assigning a number to it. The range is 1 to 1001; do not enter leading zeros. If no name is entered for the VLAN, the default is to append the <i>vlan-id</i> with leading zeros to the word VLAN. For example, VLAN0004 is a default VLAN name for VLAN 4.
Step 3	vlan <i>vlan-id</i> mtu <i>mtu-size</i>	(Optional) To modify a VLAN, identify the VLAN and change a characteristic, such as the MTU size.
Step 4	exit	Update the VLAN database, propagate it throughout the administrative domain, and return to privileged EXEC mode.

	Command	Purpose
Step 5	<code>show vlan {name <i>vlan-name</i> id <i>vlan-id</i>}</code>	Verify your entries.
Step 6	<code>copy running-config startup config</code>	(Optional) If the switch is in VTP transparent mode, the VLAN configuration is saved in the running configuration file as well as in the VLAN database. This saves the configuration in the switch startup configuration file.

To return the VLAN name to the default settings, use the `no vlan vlan-id name` or `no vlan vlan-id mtu` VLAN configuration command.

This example shows how to use VLAN configuration mode to create Ethernet VLAN 20, name it `test20`, and add it to the VLAN database:

```
Switch# vlan database
Switch(vlan)# vlan 20 name test20
Switch(vlan)# exit
APPLY completed.
Exiting...
Switch#
```

Deleting a VLAN

When you delete a VLAN from a switch that is in VTP server mode, the VLAN is removed from the VLAN database for all switches in the VTP domain. When you delete a VLAN from a switch that is in VTP transparent mode, the VLAN is deleted only on that specific switch.

You cannot delete the default VLANs for the different media types: Ethernet VLAN 1 and FDDI or Token Ring VLANs 1002 to 1005.



Caution

When you delete a VLAN, any ports assigned to that VLAN become inactive. They remain associated with the VLAN (and thus inactive) until you assign them to a new VLAN.

Beginning in privileged EXEC mode, follow these steps to delete a VLAN on the switch by using global configuration mode:

	Command	Purpose
Step 1	<code>configure terminal</code>	Enter global configuration mode.
Step 2	<code>no vlan <i>vlan-id</i></code>	Remove the VLAN by entering the VLAN ID.
Step 3	<code>end</code>	Return to privileged EXEC mode.
Step 4	<code>show vlan brief</code>	Verify the VLAN removal.
Step 5	<code>copy running-config startup config</code>	(Optional) If the switch is in VTP transparent mode, the VLAN configuration is saved in the running configuration file as well as in the VLAN database. This saves the configuration in the switch startup configuration file.

To delete a VLAN by using VLAN configuration mode, use the `vlan database` privileged EXEC command to enter VLAN configuration mode and the `no vlan vlan-id` VLAN configuration command.

Assigning Static-Access Ports to a VLAN

You can assign a static-access port to a VLAN without having VTP globally propagate VLAN configuration information (VTP is disabled). If you are assigning a port on a cluster member switch to a VLAN, first use the **rcommand** privileged EXEC command to log in to the member switch.



Note

If you assign an interface to a VLAN that does not exist, the new VLAN is created. (See the [“Creating or Modifying an Ethernet VLAN”](#) section on page 10-8.)

Beginning in privileged EXEC mode, follow these steps to assign a port to a VLAN in the VLAN database:

	Command	Purpose
Step 1	configure terminal	Enter global configuration mode
Step 2	interface <i>interface-id</i>	Enter the interface to be added to the VLAN.
Step 3	switchport mode access	Define the VLAN membership mode for the port (Layer 2 access port).
Step 4	switchport access vlan <i>vlan-id</i>	Assign the port to a VLAN. Valid VLAN IDs are 1 to 4094; do not enter leading zeros.
Step 5	end	Return to privileged EXEC mode.
Step 6	show running-config interface <i>interface-id</i>	Verify the VLAN membership mode of the interface.
Step 7	show interfaces <i>interface-id</i> switchport	Verify your entries in the <i>Administrative Mode</i> and the <i>Access Mode VLAN</i> fields of the display.
Step 8	copy running-config startup-config	(Optional) Save your entries in the configuration file.

To return an interface to its default configuration, use the **default interface** *interface-id* interface configuration command.

This example shows how to configure Fast Ethernet interface 0/1 as an access port in VLAN 2:

```
Switch# configure terminal
Enter configuration commands, one per line.  End with CNTL/Z.
Switch(config)# interface fastethernet0/1
Switch(config-if)# switchport mode access
Switch(config-if)# switchport access vlan 2
Switch(config-if)# end
Switch#
```

Configuring Extended-Range VLANs

When the switch is in VTP transparent mode (VTP disabled), you can create extended-range VLANs (in the range 1006 to 4094). Extended-range VLANs enable service providers to extend their infrastructure to a greater number of customers. The extended-range VLAN IDs are allowed for any switchport commands that allow VLAN IDs. You always use config-vlan mode (accessed by entering the **vlan *vlan-id*** global configuration command) to configure extended-range VLANs. The extended range is not supported in VLAN configuration mode (accessed by entering the **vlan database** privileged EXEC command).

Extended-range VLAN configurations are not stored in the VLAN database, but because VTP mode is transparent, they are stored in the switch running configuration file, and you can save the configuration in the startup configuration file by using the **copy running-config startup-config** privileged EXEC command.



Note

Although the switch supports 4094 VLAN IDs, see the “Supported VLANs” section on page 10-2 for the actual number of VLANs supported.

This section includes this information about extended-range VLANs:

- [Default VLAN Configuration, page 10-12](#)
- [Extended-Range VLAN Configuration Guidelines, page 10-12](#)
- [Creating an Extended-Range VLAN, page 10-13](#)
- [Creating an Extended-Range VLAN with an Internal VLAN ID, page 10-14](#)

Default VLAN Configuration

See [Table 10-2 on page 10-8](#) for the default configuration for Ethernet VLANs. You can change only the MTU size on extended-range VLANs; all other characteristics must remain at the default state.

Extended-Range VLAN Configuration Guidelines

Follow these guidelines when creating extended-range VLANs:

- To add an extended-range VLAN, you must use the **vlan *vlan-id*** global configuration command and access config-vlan mode. You cannot add extended-range VLANs in VLAN configuration mode (accessed by entering the **vlan database** privileged EXEC command).
- VLAN IDs in the extended range are not saved in the VLAN database and are not recognized by VTP.
- You cannot include extended-range VLANs in the pruning eligible range.
- The switch must be in VTP transparent mode when you create extended-range VLANs. If VTP mode is server or client, an error message is generated, and the extended-range VLAN is rejected.
- You can set the VTP mode to transparent in global configuration mode or in VLAN configuration mode. See the “[Disabling VTP \(VTP Transparent Mode\)](#)” section on page 11-12. You should save this configuration to the startup configuration so that the switch will boot up in VTP transparent mode. Otherwise, you will lose extended-range VLAN configuration if the switch resets.
- VLANs in the extended range are not supported by VQP. They cannot be configured by VMPS.

- STP is enabled by default on extended-range VLANs, but you can disable it by using the **no spanning-tree vlan *vlan-id*** global configuration command. When the maximum number of spanning-tree instances(128) are on the switch, spanning tree is disabled on any newly created VLANs. If the number of VLANs on the switch exceeds the maximum number of spanning tree instances, we recommend that you configure the IEEE 802.1S Multiple STP (MSTP) on your switch to map multiple VLANs to a single STP instance. For more information about MSTP, see [Chapter 15, “Configuring RSTP and MSTP.”](#)
- Each routed port on a Catalyst 3550 switch creates an internal VLAN for its use. These internal VLANs use extended-range VLAN numbers, and the internal VLAN ID cannot be used for an extended-range VLAN. If you try to create an extended-range VLAN with a VLAN ID that is already allocated as an internal VLAN, an error message is generated, and the command is rejected.
 - Because internal VLAN IDs are in the lower part of the extended range, we recommend that you create extended-range VLANs beginning from the highest number (4094) and moving to the lowest (1006) to reduce the possibility of using an internal VLAN ID.
 - Before configuring extended-range VLANs, enter the **show vlan internal usage** privileged EXEC command to see which VLANs have been allocated as internal VLANs.
 - If necessary, you can shut down the routed port assigned to the internal VLAN, which frees up the internal VLAN, and then create the extended-range VLAN and re-enable the port, which then uses another VLAN as its internal VLAN. See the [“Creating an Extended-Range VLAN with an Internal VLAN ID”](#) section on page 10-14.

Creating an Extended-Range VLAN

You create an extended-range VLAN in global configuration mode by entering the **vlan** global configuration command with a VLAN ID from 1006 to 4094. This command accesses the **config-vlan** mode. The extended-range VLAN has the default Ethernet VLAN characteristics (see [Table 10-2](#)) and the MTU size is the only parameter you can change. Refer to the description of the **vlan** global configuration command in the command reference for defaults of all parameters. If you enter an extended-range VLAN ID when the switch is not in VTP transparent mode, an error message is generated when you exit from **config-vlan** mode, and the extended-range VLAN is not created.

Extended-range VLANs are not saved in the VLAN database; they are saved in the switch running configuration file. You can save the extended-range VLAN configuration in the switch startup configuration file by using the **copy running-config startup-config** privileged EXEC command.



Note

Before you create an extended-range VLAN, you can verify that the VLAN ID is not used internally by entering the **show vlan internal usage** privileged EXEC command. If the VLAN ID is used internally and you want to free it up, go to the [“Creating an Extended-Range VLAN with an Internal VLAN ID”](#) section on page 10-14 before creating the extended-range VLAN.

Beginning in privileged EXEC mode, follow these steps to create an extended-range VLAN:

	Command	Purpose
Step 1	configure terminal	Enter global configuration mode.
Step 2	vtp mode transparent	Configure the switch for VTP transparent mode, disabling VTP.
Step 3	vlan <i>vlan-id</i>	Enter an extended-range VLAN ID and enter config-vlan mode. The range is 1006 to 4094.

	Command	Purpose
Step 4	mtu <i>mtu-size</i>	(Optional) Modify the VLAN by changing the MTU size. Note Although all commands appear in the CLI help in config-vlan mode, only the mtu <i>mtu-size</i> command is supported for extended-range VLANs.
Step 5	end	Return to privileged EXEC mode.
Step 6	show vlan id <i>vlan-id</i>	Verify that the VLAN has been created.
Step 7	copy running-config startup config	Save your entries in the switch startup configuration file. To save extended-range VLAN configurations, you need to save the VTP transparent mode configuration and the extended-range VLAN configuration in the switch startup configuration file. Otherwise, if the switch resets, it will default to VTP server mode, and the extended-range VLAN IDs will not be saved.

To delete an extended-range VLAN, use the **no vlan** *vlan-id* global configuration command.

The procedure for assigning static-access ports to an extended-range VLAN is the same as for normal-range VLANs. See the “[Assigning Static-Access Ports to a VLAN](#)” section on page 10-11.

This example shows how to create a new extended-range VLAN with all default characteristics, enter config-vlan mode, and save the new VLAN in the switch startup configuration file:

```
Switch(config)# vtp mode transparent
Switch(config)# vlan 2000
Switch(config-vlan)# end
Switch# copy running-config startup config
```

Creating an Extended-Range VLAN with an Internal VLAN ID

If you enter an extended-range VLAN ID that is already assigned to an internal VLAN, an error message is generated, and the extended-range VLAN is rejected. To manually free an internal VLAN ID, you must temporarily shut down the routed port that is using the internal VLAN ID.

Beginning in privileged EXEC mode, follow these steps to release a VLAN ID that is assigned to an internal VLAN and to create an extended-range VLAN with that ID:

	Command	Purpose
Step 1	show vlan internal usage	Display the VLAN IDs being used internally by the switch. If the VLAN ID that you want to use is an internal VLAN, the display shows the routed port that is using the VLAN ID. Enter that port number in Step 3.
Step 2	configure terminal	Enter global configuration mode.
Step 3	interface <i>interface-id</i>	Enter the interface ID for the routed port that is using the VLAN ID.
Step 4	shutdown	Shut down the port to free the internal VLAN ID.
Step 5	exit	Return to global configuration mode.
Step 6	vtp mode transparent	Set the VTP mode to transparent for creating extended-range VLANs.
Step 7	vlan <i>vlan-id</i>	Enter the new extended-range VLAN ID, and enter config-vlan mode.
Step 8	exit	Exit from config-vlan mode, and return to global configuration mode.
Step 9	interface <i>interface-id</i>	Enter the interface ID for the routed port that you shut down in Step 4.

	Command	Purpose
Step 10	no shutdown	Re-enable the routed port. It will be assigned a new internal VLAN ID.
Step 11	end	Return to privileged EXEC mode.
Step 12	copy running-config startup config	Save your entries in the switch startup configuration file. To save an extended-range VLAN configuration, you need to save the VTP transparent mode configuration and the extended-range VLAN configuration in the switch startup configuration file. Otherwise, if the switch resets, it will default to VTP server mode, and the extended-range VLAN IDs will not be saved.

Displaying VLANs

Use the **show vlan** privileged EXEC command to display a list of all VLANs on the switch, including extended-range VLANs. The display includes VLAN status, ports, and configuration information. To view normal-range VLANs in the VLAN database (1 to 1005,) use the **show VLAN** configuration command (accessed by entering the **vlan database** privileged EXEC command). For a list of the VLAN IDs on the switch, use the **show running-config vlan** privileged EXEC command, optionally entering a VLAN ID range.

Table 10-3 lists the commands for monitoring VLANs.

Table 10-3 VLAN Monitoring Commands

Command	Command Mode	Purpose
show	VLAN configuration	Display status of VLANs in the VLAN database.
show current [vlan-id]	VLAN configuration	Display status of all or the specified VLAN in the VLAN database.
show interfaces [vlan vlan-id]	Privileged EXEC	Display characteristics for all interfaces or for the specified VLAN configured on the switch.
show running-config vlan	Privileged EXEC	Display all or a range of VLANs on the switch.
show vlan [id vlan-id]	Privileged EXEC	Display parameters for all VLANs or the specified VLAN on the switch.

For more details about the show command options and explanations of output fields, refer to the command reference for this release.

Configuring VLAN Trunks

These sections describe how VLAN trunks function on the switch:

- [Trunking Overview, page 10-16](#)
- [Encapsulation Types, page 10-18](#)
- [Default Layer 2 Ethernet Interface VLAN Configuration, page 10-18](#)

Trunking Overview

A trunk is a point-to-point link between one or more Ethernet switch interfaces and another networking device such as a router or a switch. Fast Ethernet and Gigabit Ethernet trunks carry the traffic of multiple VLANs over a single link, and you can extend the VLANs across an entire network.

Two trunking encapsulations are available on all Ethernet interfaces:

- Inter-Switch Link (ISL)—ISL is Cisco-proprietary trunking encapsulation.
- 802.1Q—802.1Q is industry-standard trunking encapsulation.

Figure 10-2 shows a network of switches that are connected by ISL trunks.

Figure 10-2 Switches in an ISL Trunking Environment

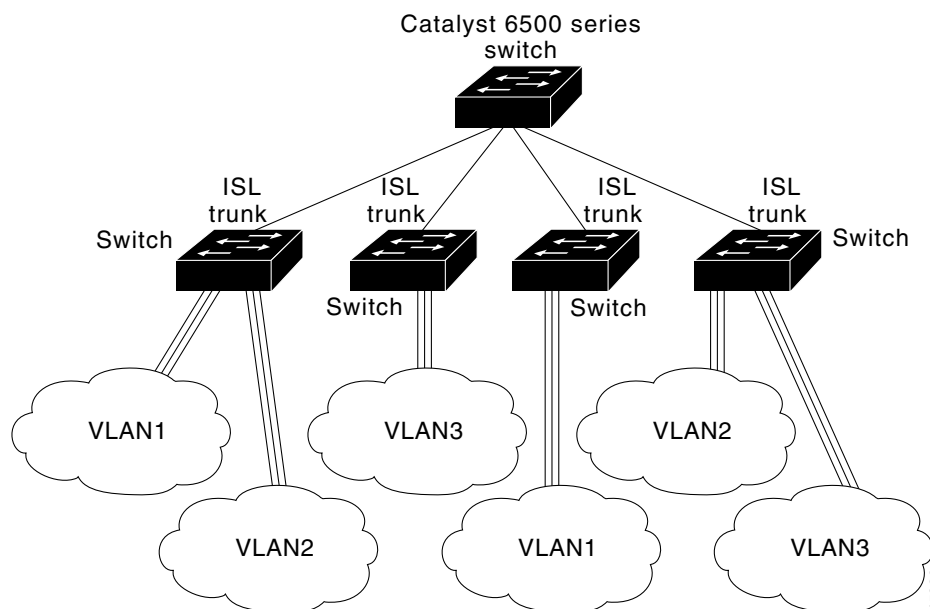

You can configure a trunk on a single Ethernet interface or on an EtherChannel bundle. For more information about EtherChannel, see [Chapter 28, “Configuring EtherChannels.”](#)

Ethernet trunk interfaces support different trunking modes (see [Table 10-4](#)). You can set an interface as trunking or nontrunking or to negotiate trunking with the neighboring interface. To autonegotiate trunking, the interfaces must be in the same VTP domain.

Trunk negotiation is managed by the Dynamic Trunking Protocol (DTP), which is a Point-to-Point Protocol. However, some networking devices might forward DTP frames improperly, which could cause misconfigurations.

To avoid this, you should configure interfaces connected to devices that do not support DTP to not forward DTP frames, that is, to turn off DTP.

- If you do not intend to trunk across those links, use the **switchport mode access** interface configuration command to disable trunking.
- To enable trunking to a device that does not support DTP, use the **switchport mode trunk** and **switchport nonegotiate** interface configuration commands to cause the interface to become a trunk but to not generate DTP frames.

**Note**

On GigaStack GBICs, dynamic trunking is only supported when only one port of a GigaStack GBIC is being used. If trunking is required on a GigaStack GBIC where both ports are in use, use the **switchport mode trunk** and **switchport nonegotiate** interface configuration commands on both GBIC interfaces to cause the interfaces to become trunks.

You can also specify whether the trunk uses ISL or 802.1Q encapsulation or if the encapsulation type is autonegotiated. The DTP supports autonegotiation of both ISL and 802.1Q trunks.

**Note**

Tunnel ports do not support DTP. See [Chapter 13, “Configuring 802.1Q and Layer 2 Protocol Tunneling,”](#) for more information on tunnel ports.

Table 10-4 Layer 2 Interface Modes

Mode	Function
switchport mode access	Puts the interface (access port) into permanent nontrunking mode and negotiates to convert the link into a nontrunk link. The interface becomes a nontrunk interface even if the neighboring interface is not a trunk interface.
switchport mode dynamic desirable	Makes the interface actively attempt to convert the link to a trunk link. The interface becomes a trunk interface if the neighboring interface is set to <i>trunk</i> , <i>desirable</i> , or <i>auto</i> mode. The default switch-port mode for all Ethernet interfaces is dynamic desirable .
switchport mode dynamic auto	Makes the interface able to convert the link to a trunk link. The interface becomes a trunk interface if the neighboring interface is set to <i>trunk</i> or <i>desirable</i> mode.
switchport mode trunk	Puts the interface into permanent trunking mode and negotiates to convert the link into a trunk link. The interface becomes a trunk interface even if the neighboring interface is not a trunk interface.
switchport nonegotiate	Prevents the interface from generating DTP frames. You can use this command only when the interface switchport mode is access or trunk . You must manually configure the neighboring interface as a trunk interface to establish a trunk link.
switchport mode dot1q-tunnel	Configures the interface as a tunnel (nontrunking) port to be connected in an asymmetric link with an 802.1Q trunk port. 802.1Q tunneling is used to maintain customer VLAN integrity across a service provider network. See Chapter 13, “Configuring 802.1Q and Layer 2 Protocol Tunneling,” for more information on tunnel ports.

Encapsulation Types

Table 10-5 lists the Ethernet trunk encapsulation types and keywords.

Table 10-5 Ethernet Trunk Encapsulation Types

Encapsulation	Function
<code>switchport trunk encapsulation isl</code>	Specifies ISL encapsulation on the trunk link.
<code>switchport trunk encapsulation dot1q</code>	Specifies 802.1Q encapsulation on the trunk link.
<code>switchport trunk encapsulation negotiate</code>	Specifies that the interface negotiate with the neighboring interface to become an ISL (preferred) or 802.1Q trunk, depending on the configuration and capabilities of the neighboring interface.



Note

The switch does not support Layer 3 trunks; you cannot configure subinterfaces or use the **encapsulation** keyword on Layer 3 interfaces. The switch does support Layer 2 trunks and Layer 3 VLAN interfaces, which provide equivalent capabilities.

The trunking mode, the trunk encapsulation type, and the hardware capabilities of the two connected interfaces determine whether a link becomes an ISL or 802.1Q trunk.

802.1Q Configuration Considerations

802.1Q trunks impose these limitations on the trunking strategy for a network:

- In a network of Cisco switches connected through 802.1Q trunks, the switches maintain one instance of spanning tree for each VLAN allowed on the trunks. Non-Cisco devices might support one spanning-tree instance for all VLANs.

When you connect a Cisco switch to a non-Cisco device through an 802.1Q trunk, the Cisco switch combines the spanning-tree instance of the VLAN of the trunk with the spanning-tree instance of the non-Cisco 802.1Q switch. However, spanning-tree information for each VLAN is maintained by Cisco switches separated by a cloud of non-Cisco 802.1Q switches. The non-Cisco 802.1Q cloud separating the Cisco switches is treated as a single trunk link between the switches.

- Make sure the native VLAN for an 802.1Q trunk is the same on both ends of the trunk link. If the native VLAN on one end of the trunk is different from the native VLAN on the other end, spanning-tree loops might result.
- Disabling spanning tree on the native VLAN of an 802.1Q trunk without disabling spanning tree on every VLAN in the network can potentially cause spanning-tree loops. We recommend that you leave spanning tree enabled on the native VLAN of an 802.1Q trunk or disable spanning tree on every VLAN in the network. Make sure your network is loop-free before disabling spanning tree.

Default Layer 2 Ethernet Interface VLAN Configuration

Table 10-6 shows the default Layer 2 Ethernet interface VLAN configuration.

Table 10-6 Default Layer 2 Ethernet Interface VLAN Configuration

Feature	Default Setting
Interface mode	switchport mode dynamic desirable
Trunk encapsulation	switchport trunk encapsulation negotiate
Allowed VLAN range	VLANs 1 to 4094
VLAN range eligible for pruning	VLANs 2 to 1001
Default VLAN (for access ports)	VLAN 1
Native VLAN (for 802.1Q trunks)	VLAN 1

Configuring an Ethernet Interface as a Trunk Port

Because trunk ports send and receive VTP advertisements, to use VTP you must ensure that at least one trunk port is configured on the switch and that this trunk port is connected to the trunk port of a second switch. Otherwise, the switch cannot receive any VTP advertisements.

This section includes these procedures for configuring an Ethernet interface as a trunk port on the switch:

- [Interaction with Other Features, page 10-19](#)
- [Defining the Allowed VLANs on a Trunk, page 10-21](#)
- [Changing the Pruning-Eligible List, page 10-22](#)
- [Configuring the Native VLAN for Untagged Traffic, page 10-22](#)



Note

By default, an interface is in Layer 2 mode. The default mode for Layer 2 interfaces is **switchport mode dynamic desirable**. If the neighboring interface supports trunking and is configured to allow trunking, the link is a Layer 2 trunk or, if the interface is in Layer 3 mode, it becomes a Layer 2 trunk when you enter the **switchport** interface configuration command. By default, trunks negotiate encapsulation. If the neighboring interface supports ISL and 802.1Q encapsulation and both interfaces are set to negotiate the encapsulation type, the trunk uses ISL encapsulation.

Interaction with Other Features

Trunking interacts with other features in these ways:

- A trunk port cannot be a secure port.
- A trunk port cannot be a tunnel port.
- Trunk ports can be grouped into EtherChannel port groups, but all trunks in the group must have the same configuration. When a group is first created, all ports follow the parameters set for the first port to be added to the group. If you change the configuration of one of these parameters, the switch propagates the setting you entered to all ports in the group:
 - allowed-VLAN list
 - STP port priority for each VLAN
 - STP Port Fast setting
 - trunk status: if one port in a port group ceases to be a trunk, all ports cease to be trunks.

- If you try to enable 802.1X on a trunk port, an error message appears, and 802.1X is not enabled. If you try to change the mode of an 802.1X-enabled port to trunk, the port mode is not changed.
- A port in dynamic mode can negotiate with its neighbor to become a trunk port. If you try to enable 802.1X on a dynamic port, an error message appears, and 802.1X is not enabled. If you try to change the mode of an 802.1X-enabled port to dynamic, the port mode is not changed.

Configuring a Trunk Port

Beginning in privileged EXEC mode, follow these steps to configure a port as an ISL or 802.1Q trunk port:

	Command	Purpose
Step 1	<code>configure terminal</code>	Enter global configuration mode.
Step 2	<code>interface interface-id</code>	Enter the interface configuration mode and the port to be configured for trunking.
Step 3	<code>switchport trunk encapsulation {isl dot1q negotiate}</code>	Configure the port to support ISL or 802.1Q encapsulation or to negotiate (the default) with the neighboring interface for encapsulation type. You must configure each end of the link with the same encapsulation type.
Step 4	<code>switchport mode {dynamic {auto desirable} trunk}</code>	Configure the interface as a Layer 2 trunk (required only if the interface is a Layer 2 access port or tunnel port, or to specify the trunking mode). <ul style="list-style-type: none"> • dynamic auto—Set the interface to a trunk link if the neighboring interface is set to trunk or desirable mode. • dynamic desirable—Set the interface to a trunk link if the neighboring interface is set to trunk, desirable, or auto mode. • trunk—Set the interface in permanent trunking mode and negotiate to convert the link to a trunk link even if the neighboring interface is not a trunk interface.
Step 5	<code>switchport access vlan vlan-id</code>	(Optional) Specify the default VLAN, which is used if the interface stops trunking.
Step 6	<code>switchport trunk native vlan vlan-id</code>	Specify the native VLAN for 802.1Q trunks.
Step 7	<code>end</code>	Return to privileged EXEC mode.
Step 8	<code>show interfaces interface-id switchport</code>	Display the switchport configuration of the interface in the <i>Administrative Mode</i> and the <i>Administrative Trunking Encapsulation</i> fields of the display.
Step 9	<code>show interfaces interface-id trunk</code>	Display the trunk configuration of the interface.
Step 10	<code>copy running-config startup-config</code>	(Optional) Save your entries in the configuration file.

To return an interface to its default configuration, use the **default interface interface-id** interface configuration command. To reset all trunking characteristics of a trunking interface to the defaults, use the **no switchport trunk** interface configuration command. To disable trunking, use the **switchport mode access** interface configuration command to configure the port as a static-access port.

This example shows how to configure the Fast Ethernet interface 0/4 as an 802.1Q trunk. The example assumes that the neighbor interface is configured to support 802.1Q trunking.

```
Switch# configure terminal
Enter configuration commands, one per line. End with CNTL/Z.
Switch(config)# interface fastethernet0/4
Switch(config-if)# switchport mode dynamic desirable
Switch(config-if)# switchport trunk encapsulation dot1q
Switch(config-if)# end
```

Defining the Allowed VLANs on a Trunk

By default, a trunk port sends traffic to and receives traffic from all VLANs. All VLAN IDs, 1 to 4094, are allowed on each trunk. However, you can remove VLANs from the allowed list, preventing traffic from those VLANs from passing over the trunk. To restrict the traffic a trunk carries, use the **switchport trunk allowed vlan remove *vlan-list*** interface configuration command to remove specific VLANs from the allowed list.



Note

You cannot remove VLAN 1 or VLANs 1002 to 1005 from the allowed VLAN list.

A trunk port can become a member of a VLAN if the VLAN is enabled, if VTP knows of the VLAN, and if the VLAN is in the allowed list for the port. When VTP detects a newly enabled VLAN and the VLAN is in the allowed list for a trunk port, the trunk port automatically becomes a member of the enabled VLAN. When VTP detects a new VLAN and the VLAN is not in the allowed list for a trunk port, the trunk port does not become a member of the new VLAN.

Beginning in privileged EXEC mode, follow these steps to modify the allowed list of an ISL or 802.1Q trunk:

	Command	Purpose
Step 1	configure terminal	Enter global configuration mode.
Step 2	interface <i>interface-id</i>	Enter interface configuration mode and the port to be configured.
Step 3	switchport mode trunk	Configure the interface as a VLAN trunk port.
Step 4	switchport trunk allowed vlan {add all except remove} <i>vlan-list</i>	(Optional) Configure the list of VLANs allowed on the trunk. For explanations about using the add , all , except , and remove keywords, refer to the command reference for this release. The <i>vlan-list</i> parameter is either a single VLAN number from 1 to 4094 or a range of VLANs described by two VLAN numbers, the lower one first, separated by a hyphen. Do not enter any spaces between comma-separated VLAN parameters or in hyphen-specified ranges. All VLANs are allowed by default. You cannot remove any of the default VLANs (1 or 1002 to 1005) from a trunk.
Step 5	end	Return to privileged EXEC mode.
Step 6	show interfaces <i>interface-id</i> switchport	Verify your entries in the <i>Trunking VLANs Enabled</i> field of the display.
Step 7	copy running-config startup-config	(Optional) Save your entries in the configuration file.

To return to the default allowed VLAN list of all VLANs, use the **no switchport trunk allowed vlan** interface configuration command.

This example shows how to remove VLAN 2 from the allowed VLAN list:

```
Switch(config)# interface fastethernet0/1
Switch(config-if)# switchport trunk allowed vlan remove 2
Switch(config-if)# end
Switch#
```

Changing the Pruning-Eligible List

The pruning-eligible list applies only to trunk ports. Each trunk port has its own eligibility list. VTP pruning must be enabled for this procedure to take effect. The [“Enabling VTP Pruning”](#) section on page 11-14 describes how to enable VTP pruning.

Beginning in privileged EXEC mode, follow these steps to remove VLANs from the pruning-eligible list on a trunk port:

	Command	Purpose
Step 1	configure terminal	Enter global configuration mode.
Step 2	interface <i>interface-id</i>	Enter interface configuration mode, and select the trunk port for which VLANs should be pruned.
Step 3	switchport trunk pruning vlan { add except none remove } <i>vlan-list</i> [, <i>vlan</i> [, <i>vlan</i> [,]]]	Configure the list of VLANs allowed to be pruned from the trunk. (See the “VTP Pruning” section on page 11-4). For explanations about using the add , except , none , and remove keywords, refer to the command reference for this release. Separate nonconsecutive VLAN IDs with a comma and no spaces; use a hyphen to designate a range of IDs. Valid IDs are from 2 to 1001. Extended-range VLANs (VLAN IDs 1006 to 4094) cannot be pruned. VLANs that are pruning-ineligible receive flooded traffic. The default list of VLANs allowed to be pruned contains VLANs 2 to 1001.
Step 4	end	Return to privileged EXEC mode.
Step 5	show interfaces <i>interface-id</i> switchport	Verify your entries in the <i>Pruning VLANs Enabled</i> field of the display.
Step 6	copy running-config startup-config	(Optional) Save your entries in the configuration file.

To return to the default pruning-eligible list of all VLANs, use the **no switchport trunk pruning vlan** interface configuration command.

Configuring the Native VLAN for Untagged Traffic

A trunk port configured with 802.1Q tagging can receive both tagged and untagged traffic. By default, the switch forwards untagged traffic in the native VLAN configured for the port. The native VLAN is VLAN 1 by default.



Note

The native VLAN can be assigned any VLAN ID.

For information about 802.1Q configuration issues, see the [“802.1Q Configuration Considerations”](#) section on page 10-18.

Beginning in privileged EXEC mode, follow these steps to configure the native VLAN on an 802.1Q trunk:

	Command	Purpose
Step 1	configure terminal	Enter global configuration mode.
Step 2	interface <i>interface-id</i>	Enter interface configuration mode, and define the interface that is configured as the 802.1Q trunk.
Step 3	switchport trunk native vlan <i>vlan-id</i>	Configure the VLAN that is sending and receiving untagged traffic on the trunk port. For <i>vlan-id</i> , the range is 1 to 4094. Do not enter leading zeros.
Step 4	end	Return to privileged EXEC mode.
Step 5	show interfaces <i>interface-id</i> switchport	Verify your entries in the <i>Trunking Native Mode VLAN</i> field.
Step 6	copy running-config startup-config	(Optional) Save your entries in the configuration file.

To return to the default native VLAN, VLAN 1, use the **no switchport trunk native vlan** interface configuration command.

If a packet has a VLAN ID that is the same as the outgoing port native VLAN ID, the packet is sent untagged; otherwise, the switch sends the packet with a tag.

Load Sharing Using STP

Load sharing divides the bandwidth supplied by parallel trunks connecting switches. To avoid loops, STP normally blocks all but one parallel link between switches. Using load sharing, you divide the traffic between the links according to which VLAN the traffic belongs.

You configure load sharing on trunk ports by using STP port priorities or STP path costs. For load sharing using STP port priorities, both load-sharing links must be connected to the same switch. For load sharing using STP path costs, each load-sharing link can be connected to the same switch or to two different switches. For more information about STP, see [Chapter 14, “Configuring STP.”](#)

Load Sharing Using STP Port Priorities

When two ports on the same switch form a loop, the STP port priority setting determines which port is enabled and which port is in a blocking state. You can set the priorities on a parallel trunk port so that the port carries all the traffic for a given VLAN. The trunk port with the higher priority (lower values) for a VLAN is forwarding traffic for that VLAN. The trunk port with the lower priority (higher values) for the same VLAN remains in a blocking state for that VLAN. One trunk port sends or receives all traffic for the VLAN.

[Figure 10-3](#) shows two trunks connecting supported switches. In this example, the switches are configured as follows:

- VLANs 8 through 10 are assigned a port priority of 10 on Trunk 1.
- VLANs 3 through 6 retain the default port priority of 128 on Trunk 1.
- VLANs 3 through 6 are assigned a port priority of 10 on Trunk 2.
- VLANs 8 through 10 retain the default port priority of 128 on Trunk 2.

In this way, Trunk 1 carries traffic for VLANs 8 through 10, and Trunk 2 carries traffic for VLANs 3 through 6. If the active trunk fails, the trunk with the lower priority takes over and carries the traffic for all of the VLANs. No duplication of traffic occurs over any trunk port.

Figure 10-3 Load Sharing by Using STP Port Priorities

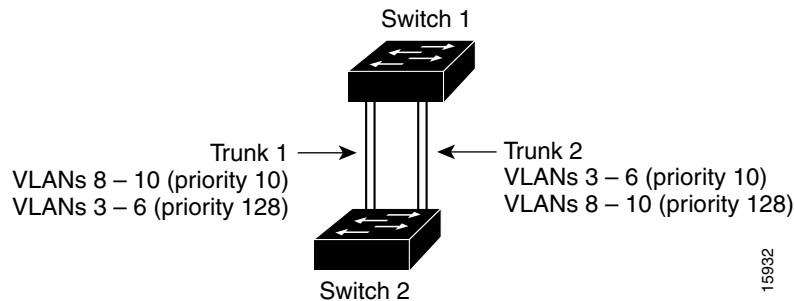

Beginning in privileged EXEC mode, follow these steps to configure the network shown in [Figure 10-3](#).

	Command	Purpose
Step 1	configure terminal	Enter global configuration mode on Switch 1.
Step 2	vtp domain <i>domain-name</i>	Configure a VTP administrative domain. The domain name can be from 1 to 32 characters.
Step 3	vtp mode server	Configure Switch 1 as the VTP server.
Step 4	end	Return to privileged EXEC mode.
Step 5	show vtp status	Verify the VTP configuration on both Switch 1 and Switch 2. In the display, check the <i>VTP Operating Mode</i> and the <i>VTP Domain Name</i> fields.
Step 6	show vlan	Verify that the VLANs exist in the database on Switch 1.
Step 7	configure terminal	Enter global configuration mode.
Step 8	interface fastethernet 0/1	Enter interface configuration mode, and define Fast Ethernet port 0/1 as the interface to be configured as a trunk.
Step 9	switchport trunk encapsulation {isl dot1q negotiate}	Configure the port to support ISL or 802.1Q encapsulation or to negotiate with the neighboring interface. You must configure each end of the link with the same encapsulation type.
Step 10	switchport mode trunk	Configure the port as a trunk port.
Step 11	end	Return to privilege EXEC mode.
Step 12	show interfaces fastethernet0/1 switchport	Verify the VLAN configuration.
Step 13		Repeat Steps 7 through 11 on Switch 1 for Fast Ethernet port 0/2.
Step 14		Repeat Steps 7 through 11 on Switch 2 to configure the trunk ports on Fast Ethernet ports 0/1 and 0/2.
Step 15	show vlan	When the trunk links come up, VTP passes the VTP and VLAN information to Switch 2. Verify that Switch 2 has learned the VLAN configuration.

	Command	Purpose
Step 16	<code>configure terminal</code>	Enter global configuration mode on Switch 1.
Step 17	<code>interface fastethernet0/1</code>	Enter interface configuration mode, and define the interface to set the STP port priority.
Step 18	<code>spanning-tree vlan 8 port-priority 10</code>	Assign the port priority of 10 for VLAN 8.
Step 19	<code>spanning-tree vlan 9 port-priority 10</code>	Assign the port priority of 10 for VLAN 9.
Step 20	<code>spanning-tree vlan 10 port-priority 10</code>	Assign the port priority of 10 for VLAN 10.
Step 21	<code>exit</code>	Return to global configuration mode.
Step 22	<code>interface fastethernet0/2</code>	Enter interface configuration mode, and define the interface to set the STP port priority.
Step 23	<code>spanning-tree vlan 3 port-priority 10</code>	Assign the port priority of 10 for VLAN 3.
Step 24	<code>spanning-tree vlan 4 port-priority 10</code>	Assign the port priority of 10 for VLAN 4.
Step 25	<code>spanning-tree vlan 5 port-priority 10</code>	Assign the port priority of 10 for VLAN 5.
Step 26	<code>spanning-tree vlan 6 port-priority 10</code>	Assign the port priority of 10 for VLAN 6.
Step 27	<code>end</code>	Return to privileged EXEC mode.
Step 28	<code>show running-config</code>	Verify your entries.
Step 29	<code>copy running-config startup-config</code>	(Optional) Save your entries in the configuration file.

Load Sharing Using STP Path Cost

You can configure parallel trunks to share VLAN traffic by setting different path costs on a trunk and associating the path costs with different sets of VLANs. The VLANs keep the traffic separate. Because no loops exist, STP does not disable the ports, and redundancy is maintained in the event of a lost link.

In [Figure 10-4](#), Trunk ports 1 and 2 are 100BASE-T ports. The path costs for the VLANs are assigned as follows:

- VLANs 2 through 4 are assigned a path cost of 30 on Trunk port 1.
- VLANs 8 through 10 retain the default 100BASE-T path cost on Trunk port 1 of 19.
- VLANs 8 through 10 are assigned a path cost of 30 on Trunk port 2.
- VLANs 2 through 4 retain the default 100BASE-T path cost on Trunk port 2 of 19.

Figure 10-4 Load-Sharing Trunks with Traffic Distributed by Path Cost

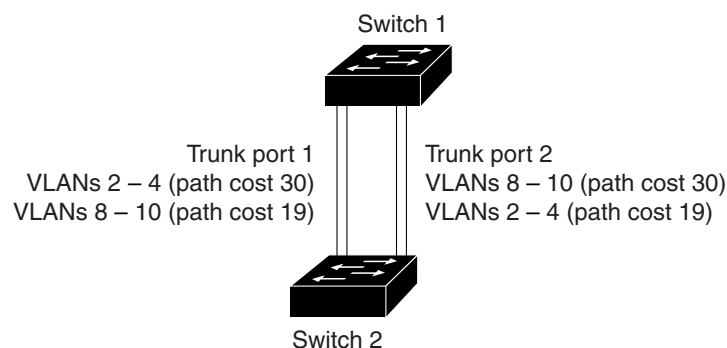

Beginning in privileged EXEC mode, follow these steps to configure the network shown in [Figure 10-4](#):

	Command	Purpose
Step 1	<code>configure terminal</code>	Enter global configuration mode on Switch 1.
Step 2	<code>interface fastethernet 0/1</code>	Enter interface configuration mode, and define Fast Ethernet port 0/1 as the interface to be configured as a trunk.
Step 3	<code>switchport trunk encapsulation {isl dot1q negotiate}</code>	Configure the port to support ISL or 802.1Q encapsulation. You must configure each end of the link with the same encapsulation type.
Step 4	<code>switchport mode trunk</code>	Configure the port as a trunk port. The trunk defaults to ISL trunking.
Step 5	<code>exit</code>	Return to global configuration mode.
Step 6		Repeat Steps 2 through 4 on Switch 1 interface Fast Ethernet 0/2.
Step 7	<code>end</code>	Return to privileged EXEC mode.
Step 8	<code>show running-config</code>	Verify your entries. In the display, make sure that interfaces Fast Ethernet 0/1 and Fast Ethernet 0/2 are configured as trunk ports.
Step 9	<code>show vlan</code>	When the trunk links come up, Switch 1 receives the VTP information from the other switches. Verify that Switch 1 has learned the VLAN configuration.
Step 10	<code>configure terminal</code>	Enter global configuration mode.
Step 11	<code>interface fastethernet 0/1</code>	Enter interface configuration mode, and define Fast Ethernet port 0/1 as the interface to set the STP cost.
Step 12	<code>spanning-tree vlan 2 cost 30</code>	Set the spanning-tree path cost to 30 for VLAN 2.
Step 13	<code>spanning-tree vlan 3 cost 30</code>	Set the spanning-tree path cost to 30 for VLAN 3.
Step 14	<code>spanning-tree vlan 4 cost 30</code>	Set the spanning-tree path cost to 30 for VLAN 4.
Step 15	<code>end</code>	Return to global configuration mode.
Step 16		Repeat Steps 9 through 11 on Switch 1 interface Fast Ethernet 0/2, and set the spanning-tree path cost to 30 for VLANs 8, 9, and 10.
Step 17	<code>exit</code>	Return to privileged EXEC mode.
Step 18	<code>show running-config</code>	Verify your entries. In the display, verify that the path costs are set correctly for interfaces Fast Ethernet 0/1 and 0/2.
Step 19	<code>copy running-config startup-config</code>	(Optional) Save your entries in the configuration file.

Configuring VMPS

The switch cannot be a VMPS server but can act as a client to the VMPS and communicate with it through the VLAN Query Protocol (VQP). VMPS dynamically assigns dynamic access port VLAN membership.

This section includes this information about configuring VMPS:

- “Understanding VMPS” section on page 10-27
- “Default VMPS Configuration” section on page 10-29
- “VMPS Configuration Guidelines” section on page 10-30
- “Configuring the VMPS Client” section on page 10-31
- “Monitoring the VMPS” section on page 10-33
- “Troubleshooting Dynamic Port VLAN Membership” section on page 10-34
- “VMPS Configuration Example” section on page 10-34

Understanding VMPS

When the VMPS receives a VQP request from a client switch, it searches its database for a MAC-address-to-VLAN mapping. The server response is based on this mapping and whether or not the server is in secure mode. Secure mode determines whether the server shuts down the port when a VLAN is not allowed on it or just denies the port access to the VLAN.

In response to a request, the VMPS takes one of these actions:

- If the assigned VLAN is restricted to a group of ports, the VMPS verifies the requesting port against this group and responds as follows:
 - If the VLAN is allowed on the port, the VMPS sends the VLAN name to the client in response.
 - If the VLAN is not allowed on the port and the VMPS is not in secure mode, the VMPS sends an *access-denied* response.
 - If the VLAN is not allowed on the port and the VMPS is in secure mode, the VMPS sends a *port-shutdown* response.
- If the VLAN in the database does not match the current VLAN on the port and active hosts exist on the port, the VMPS sends an *access-denied* or a *port-shutdown* response, depending on the secure mode of the VMPS.

If the switch receives an *access-denied* response from the VMPS, it continues to block traffic from the MAC address to or from the port. The switch continues to monitor the packets directed to the port and sends a query to the VMPS when it identifies a new address. If the switch receives a *port-shutdown* response from the VMPS, it disables the port. The port must be manually re-enabled by using the CLI, CMS, or SNMP.

You can also use an explicit entry in the configuration table to deny access to specific MAC addresses for security reasons. If you enter the **none** keyword for the VLAN name, the VMPS sends an *access-denied* or *port-shutdown* response, depending on the VMPS secure mode setting.

Dynamic Port VLAN Membership

A dynamic (nontrunking) port on the switch can belong to only one VLAN, with a VLAN ID from 1 to 1005. When the link comes up, the switch does not forward traffic to or from this port until the VMPS provides the VLAN assignment. The VMPS receives the source MAC address from the first packet of a new host connected to the dynamic port and attempts to match the MAC address to a VLAN in the VMPS database.

If there is a match, the VMPS sends the VLAN number for that port. If the client switch was not previously configured, it uses the domain name from the first VTP packet it receives on its trunk port from the VMPS. If the client switch was previously configured, it includes its domain name in the query packet to the VMPS to obtain its VLAN number. The VMPS verifies that the domain name in the packet matches its own domain name before accepting the request and responds to the client with the assigned VLAN number for the client. If there is no match, the VMPS either denies the request or shuts down the port (depending on the VMPS secure mode setting).

Multiple hosts (MAC addresses) can be active on a dynamic port if they are all in the same VLAN; however, the VMPS shuts down a dynamic port if more than 20 hosts are active on the port.

If the link goes down on a dynamic port, the port returns to an isolated state and does not belong to a VLAN. Any hosts that come online through the port are checked again through the VQP with the VMPS before the port is assigned to a VLAN.

VMPS Database Configuration File

The VMPS contains a database configuration file that you create. This ASCII text file is stored on a switch-accessible TFTP server that functions as a VMPS server. The file contains VMPS information, such as the domain name, the fallback VLAN name, and the MAC-address-to-VLAN mapping. The switch cannot act as the VMPS, but you can use a Catalyst 5000 or Catalyst 6000 series switch as the VMPS.

You can configure a fallback VLAN name. If you connect a device with a MAC address that is not in the database, the VMPS sends the fallback VLAN name to the client. If you do not configure a fallback VLAN and the MAC address does not exist in the database, the VMPS sends an *access-denied* response. If the VMPS is in secure mode, it sends a *port-shutdown* response.

Whenever port names are used in the VMPS database configuration file, the server must use the switch convention for naming ports. For example, Fa0/4 is fixed Fast Ethernet port number 4. If the switch is a cluster member, the command switch adds the name of the switch before the type. For example, *es3%Fa0/4* refers to fixed Fast Ethernet port 4 on member switch 3. When port names are required, these naming conventions must be followed in the VMPS database configuration file when it is configured to support a cluster.

This example shows an example of a VMPS database configuration file as it appears on a Catalyst 6000 series switch. The file has these characteristics:

- The security mode is open.
- The default is used for the fallback VLAN.
- MAC address-to-VLAN name mappings—The MAC address of each host and the VLAN to which each host belongs is defined.
- Port groups are defined.
- VLAN groups are defined.
- VLAN port policies are defined for the ports associated with restricted VLANs.

```
!VMPS File Format, version 1.1
! Always begin the configuration file with
! the word "VMPS"
!
!vmps domain <domain-name>
! The VMPS domain must be defined.
!vmps mode {open | secure}
! The default mode is open.
!vmps fallback <vlan-name>
!vmps no-domain-req { allow | deny }
```

```

!
! The default value is allow.
vmmps domain DSBU
vmmps mode open
vmmps fallback default
vmmps no-domain-req deny
!
!
!MAC Addresses
!
vmmps-mac-addr
!
! address <addr> vlan-name <vlan_name>
!
address 0012.2233.4455 vlan-name hardware
address 0000.6509.a080 vlan-name hardware
address aabb.ccdd.eeff vlan-name Green
address 1223.5678.9abc vlan-name ExecStaff
address fedc.ba98.7654 vlan-name --NONE--
address fedc.ba23.1245 vlan-name Purple
!
!Port Groups
!
!vmmps-port-group <group-name>
! device <device-id> { port <port-name> | all-ports }
!
vmmps-port-group WiringCloset1
  device 198.92.30.32 port 0/2
  device 172.20.26.141 port 0/8
vmmps-port-group "Executive Row"
  device 198.4.254.222 port 0/2
  device 198.4.254.222 port 0/3
  device 198.4.254.223 all-ports
!
!
!VLAN groups
!
!vmmps-vlan-group <group-name>
! vlan-name <vlan-name>
!
vmmps-vlan-group Engineering
  vlan-name hardware
  vlan-name software
!
!
!VLAN port Policies
!
!vmmps-port-policies {vlan-name <vlan_name> | vlan-group <group-name> }
! { port-group <group-name> | device <device-id> port <port-name> }
!
vmmps-port-policies vlan-group Engineering
  port-group WiringCloset1
vmmps-port-policies vlan-name Green
  device 198.92.30.32 port 0/8
vmmps-port-policies vlan-name Purple
  device 198.4.254.22 port 0/2
  port-group "Executive Row"

```

Default VMPS Configuration

Table 10-7 shows the default VMPS and dynamic port configuration on client switches.

Table 10-7 Default VMPS Client and Dynamic Port Configuration

Feature	Default Setting
VMPS domain server	None
VMPS reconfirm interval	60 minutes
VMPS server retry count	3
Dynamic ports	None configured

VMPS Configuration Guidelines

These guidelines and restrictions apply to dynamic port VLAN membership:

- You must configure the VMPS before you configure ports as dynamic.
- The communication between a cluster of switches and VMPS is managed by the command switch and includes port-naming conventions that are different from standard port names. For the cluster-based port-naming conventions, see the [“VMPS Database Configuration File”](#) section on page 10-28.
- When you configure a port as dynamic, the spanning-tree Port Fast feature is automatically enabled for that port. The Port Fast mode accelerates the process of bringing the port into the forwarding state. You can disable Port Fast mode on a dynamic port.
- 802.1X ports cannot be configured as dynamic ports. If you try to enable 802.1X on a dynamic-access (VQP) port, an error message appears, and 802.1X is not enabled. If you try to change an 802.1X-enabled port to dynamic VLAN assignment, an error message appears, and the VLAN configuration is not changed.
- Trunk ports cannot be dynamic ports, but you can enter the **switchport access vlan dynamic** interface configuration command for a trunk port. In this case, the switch retains the setting and applies it if the port is later configured as an access port.

You must turn off trunking on the port before the dynamic access setting takes effect.

- Dynamic ports cannot be monitor ports.
- Secure ports cannot be dynamic ports. You must disable port security on a port before it becomes dynamic.
- Dynamic ports cannot be members of an EtherChannel group.
- Port channels cannot be configured as dynamic ports.
- A dynamic access port can participate in fallback bridging.
- The VTP management domain of the VMPS client and the VMPS server must be the same.
- VQP does not support extended-range VLANs (VLAN IDs higher than 1006). Extended-range VLANs cannot be configured by VMPS.
- The VLAN configured on the VMPS server should not be a voice VLAN.

Configuring the VMPS Client

You configure dynamic VLANs by using the VMPS (server). The switch can be a VMPS client; it cannot be a VMPS server.

Entering the IP Address of the VMPS

You must first enter the IP address of the server to configure the switch as a client.

Note

If the VMPS is being defined for a cluster of switches, enter the address on the command switch.

Beginning in privileged EXEC mode, follow these steps to enter the IP address of the VMPS:

	Command	Purpose
Step 1	<code>configure terminal</code>	Enter global configuration mode.
Step 2	<code>vmps server ipaddress primary</code>	Enter the IP address of the switch acting as the primary VMPS server.
Step 3	<code>vmps server ipaddress</code>	Enter the IP address of the switch acting as a secondary VMPS server. You can enter up to three secondary server addresses.
Step 4	<code>end</code>	Return to privileged EXEC mode.
Step 5	<code>show vmps</code>	Verify your entries in the <i>VMPS Domain Server</i> field of the display.
Step 6	<code>copy running-config startup-config</code>	(Optional) Save your entries in the configuration file.

Note

The switch port that is connected to the VMPS server cannot be a dynamic access port. It can be either a static access port or a trunk port. See the [“Configuring an Ethernet Interface as a Trunk Port”](#) section on page 10-19.

Configuring Dynamic Access Ports on VMPS Clients

If you are configuring a port on a cluster member switch as a dynamic port, first use the **rcommand** privileged EXEC command to log into the member switch.

Caution

Dynamic port VLAN membership is for end stations or hubs connected to end stations. Connecting dynamic access ports to other switches can cause a loss of connectivity.

Beginning in privileged EXEC mode, follow these steps to configure a dynamic access port on a VMPS client switch:

	Command	Purpose
Step 1	<code>configure terminal</code>	Enter global configuration mode.
Step 2	<code>interface interface-id</code>	Enter interface configuration mode and the switch port that is connected to the end station.
Step 3	<code>switchport mode access</code>	Set the port to access mode.

	Command	Purpose
Step 4	switchport access vlan dynamic	Configure the port as eligible for dynamic VLAN membership. The dynamic access port must be connected to an end station.
Step 5	end	Return to privileged EXEC mode.
Step 6	show interfaces <i>interface-id</i> switchport	Verify your entries in the <i>Operational Mode</i> field of the display.
Step 7	copy running-config startup-config	(Optional) Save your entries in the configuration file.

To return an interface to its default configuration, use the **default interface *interface-id*** interface configuration command. To return an interface to its default switchport mode (dynamic desirable), use the **no switchport mode** interface configuration command. To reset the access mode to the default VLAN for the switch, use the **no switchport access** interface configuration command.

Reconfirming VLAN Memberships

Beginning in privileged EXEC mode, follow these steps to confirm the dynamic port VLAN membership assignments that the switch has received from the VMPS:

	Command	Purpose
Step 1	vmmps reconfirm	Reconfirm dynamic port VLAN membership.
Step 2	show vmmps	Verify the dynamic VLAN reconfirmation status.

Changing the Reconfirmation Interval

VMPS clients periodically reconfirm the VLAN membership information received from the VMPS. You can set the number of minutes after which reconfirmation occurs.

If you are configuring a member switch in a cluster, this parameter must be equal to or greater than the reconfirmation setting on the command switch. You must also first use the **recommand** privileged EXEC command to log into the member switch.

Beginning in privileged EXEC mode, follow these steps to change the reconfirmation interval:

	Command	Purpose
Step 1	configure terminal	Enter global configuration mode.
Step 2	vmmps reconfirm <i>minutes</i>	Enter the number of minutes between reconfirmations of the dynamic VLAN membership. Enter a number from 1 to 120. The default is 60 minutes.
Step 3	end	Return to privileged EXEC mode.
Step 4	show vmmps	Verify the dynamic VLAN reconfirmation status in the <i>Reconfirm Interval</i> field of the display.
Step 5	copy running-config startup-config	(Optional) Save your entries in the configuration file.

To return the switch to its default setting, use the **no vmmps reconfirm** global configuration command.

Changing the Retry Count

Beginning in privileged EXEC mode, follow these steps to change the number of times that the switch attempts to contact the VMPS before querying the next server:

	Command	Purpose
Step 1	configure terminal	Enter global configuration mode.
Step 2	vmpls retry count	Change the retry count. The retry range is from 1 to 10; the default is 3.
Step 3	end	Return to privileged EXEC mode.
Step 4	show vmpls	Verify your entry in the <i>Server Retry Count</i> field of the display.
Step 5	copy running-config startup-config	(Optional) Save your entries in the configuration file.

To return the switch to its default setting, use the **no vmpls retry** global configuration command.

Monitoring the VMPS

You can display information about the VMPS by using the **show vmpls** privileged EXEC command. The switch displays this information about the VMPS:

VMPS VQP Version	The version of VQP used to communicate with the VMPS. The switch queries the VMPS that is using VQP version 1.
Reconfirm Interval	The number of minutes the switch waits before reconfirming the VLAN-to-MAC-address assignments.
Server Retry Count	The number of times VQP resends a query to the VMPS. If no response is received after this many tries, the switch starts to query the secondary VMPS.
VMPS domain server	The IP address of the configured VLAN membership policy servers. The switch sends queries to the one marked <i>current</i> . The one marked <i>primary</i> is the primary server.
VMPS Action	The result of the most recent reconfirmation attempt. A reconfirmation attempt can occur automatically when the reconfirmation interval expired, or you can force it by entering the vmpls reconfirm privileged EXEC command or its CMS or SNMP equivalent.

This is an example of output for the **show vmps** privileged EXEC command:

```
Switch# show vmps

VQP Client Status:
-----
VMPS VQP Version: 1
Reconfirm Interval: 60 min
Server Retry Count: 3
VMPS domain server: 172.20.128.86 (primary, current)
                   172.20.128.87

Reconfirmation status
-----
VMPS Action:          No Dynamic Port
```

Troubleshooting Dynamic Port VLAN Membership

The VMPS shuts down a dynamic port under these conditions:

- The VMPS is in secure mode, and it does not allow the host to connect to the port. The VMPS shuts down the port to prevent the host from connecting to the network.
- More than 20 active hosts reside on a dynamic port.

To re-enable a disabled dynamic port, enter the **no shutdown** interface configuration command.

VMPS Configuration Example

Figure 10-5 shows a network with a VMPS server switch and VMPS client switches with dynamic ports. In this example, these assumptions apply:

- The VMPS server and the VMPS client are separate switches.
- The Catalyst 6000 series Switch 1 is the primary VMPS server.
- The Catalyst 6000 series Switch 3 and Switch 10 are secondary VMPS servers.
- End stations are connected to the Catalyst 3550 clients, Switch 2 and Switch 9.
- The database configuration file is stored on the TFTP server with the IP address 172.20.22.7.

Figure 10-5 Dynamic Port VLAN Membership Configuration

