



## Connector and Cable Specifications

---

This appendix describes the Catalyst 2960 switch ports and the cables and adapters that you use to connect the switch to other devices and includes these sections:

- [Connector Specifications, page B-1](#)
- [Cable and Adapter Specifications, page B-4](#)

### Connector Specifications

These sections describe the connectors used with the Catalyst 2960 switch:

- [10/100/1000 Ports, page B-1](#)
- [SFP Module Ports, page B-3](#)
- [Dual-Purpose Ports, page B-3](#)
- [Console Port, page B-4](#)

### 10/100/1000 Ports

The 10/100/1000 Ethernet ports on the Catalyst 2960 switch use standard RJ-45 connectors. [Figure B-1](#) shows the pinout.

**Note**

The auto-MDIX feature is enabled by default. For configuration information for this feature, see the switch software configuration guide or the switch command reference.

### Connecting to 10BASE-T- and 100BASE-TX-Compatible Devices

When connecting the ports to 10BASE-T- and 100BASE-TX-compatible devices, such as servers, workstations, and routers, you can use a two or four twisted-pair, straight-through cable wired for 10BASE-T and 100BASE-TX. [Figure B-5](#) shows the two twisted-pair, straight-through cable schematics. [Figure B-7](#) shows the four twisted-pair, straight-through cable schematics.

When connecting the ports to 10BASE-T- and 100BASE-TX-compatible devices, such as switches or repeaters, you can use a two or four twisted-pair, crossover cable. [Figure B-6](#) shows the two twisted-pair, crossover cable schematics. [Figure B-8](#) shows the four twisted-pair, crossover cable schematics.

You can use Category 3, 4, or 5 cabling when connecting to 10BASE-T-compatible devices. You must use Category 5 cabling when connecting to 100BASE-TX-compatible devices.

## Connecting to 1000BASE-T Devices

When connecting the ports to 1000BASE-T devices, such as servers, workstations, and routers, you must use a four twisted-pair, Category 5, straight-through cable wired for 10BASE-T, 100BASE-TX, and 1000BASE-T. [Figure B-7](#) shows the straight-through cable schematics.

When connecting the ports to other devices, such as switches or repeaters, you must use a four twisted-pair, Category 5 or higher crossover cable. [Figure B-8](#) shows the crossover cable schematics.



### Note

Be sure to use a four twisted-pair, Category 5 cable when connecting to a 1000BASE-T-compatible device.



### Note

Use a straight-through cable to connect two ports only when one port is designated with an X. Use a crossover cable to connect two ports when both ports are designated with an X or when both ports do not have an X.

**Figure B-1** 10/100/1000 Port Pinouts

Pin	Label	1	2	3	4	5	6	7	8
1	TP0+								
2	TP0-								
3	TP1+								
4	TP2+								
5	TP2-								
6	TP1-								
7	TP3+								
8	TP3-								

## SFP Module Ports

The Catalyst 2960 switch uses SFP modules for fiber-optic and copper uplink ports. See the Catalyst 2960 switch release notes for a list of supported SFP modules.

**Figure B-2** Fiber-Optic SFP Module LC Connector

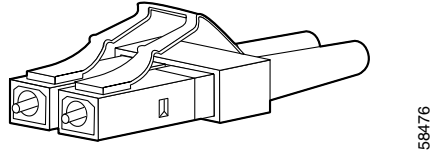

**Warning**

Invisible laser radiation may be emitted from disconnected fibers or connectors. Do not stare into beams or view directly with optical instruments.

**Figure B-3** Copper SFP Module RJ-45 Connector

Pin	Label	1 2 3 4 5 6 7 8
1	TP0+	
2	TP0-	
3	TP1+	
4	TP2+	
5	TP2-	
6	TP1-	
7	TP3+	
8	TP3-	

60915

## Dual-Purpose Ports

The Ethernet port on a dual-purpose port uses standard RJ-45 connectors. [Figure B-4](#) shows the pinouts.

The SFP module slot on a dual-purpose port uses SFP modules for fiber-optic and copper uplink ports. See the Catalyst 2960 switch release notes for a list of supported SFP modules.



**Note**

The auto-MDIX feature is enabled by default. For configuration information for this feature, see the switch software configuration guide or the switch command reference.

**Figure B-4** 10/100/1000 Port Pinouts

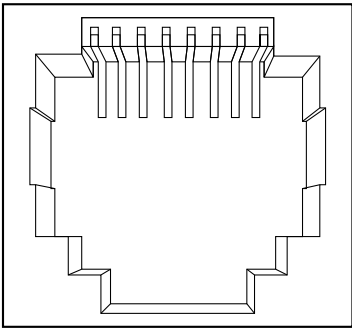
Pin	Label	1 2 3 4 5 6 7 8
1	TP0+	
2	TP0-	
3	TP1+	
4	TP2+	
5	TP2-	
6	TP1-	
7	TP3+	
8	TP3-	

60915

## Console Port

The console port uses an 8-pin RJ-45 connector, which is described in [Table B-2](#) and [Table B-3](#). The supplied RJ-45-to-DB-9 adapter cable is used to connect the console port of the switch to a console PC. You need to provide a RJ-45-to-DB-25 female DTE adapter if you want to connect the switch console port to a terminal. You can order a kit (part number ACS-DSBUASYN=) containing that adapter from Cisco. For console port and adapter pinout information, see [Table B-2](#) and [Table B-3](#).

## Cable and Adapter Specifications

These sections describe the cables and adapters used with Catalyst 2960 switches:

- [SFP Module Cable Specifications](#), page B-4
- [Two Twisted-Pair Cable Pinouts](#), page B-6
- [Four Twisted-Pair Cable Pinouts for 1000BASE-T Ports](#), page B-6
- [Crossover Cable and Adapter Pinouts](#), page B-7

## SFP Module Cable Specifications

[Table B-1](#) lists the cable specifications for the fiber-optic SFP module connections. Each port must match the wave-length specifications on the other end of the cable, and for reliable communications, the cable must not exceed the required cable length. Copper 1000BASE-T SFP transceivers use standard four twisted-pair, Category 5 or greater cable at lengths up to 328 feet (100 meters).

Table B-1 Fiber-Optic SFP Module Port Cabling Specifications

SFP Module	Wavelength (nanometers)	Fiber Type	Core Size/Cladding Size (micron)	Modal Bandwidth (MHz/km) <sup>1</sup>	Cable Distance
100BASE-BX (GLC-FE-100BX-D GLC-FE-100BX-U)	1310 TX 1550 RX	SMF	G.652 <sup>2</sup>	—	32,810 feet (10 km)
100BASE-FX (GLC-GE-100FX)	1310	MMF	50/125 62.5/125	500 500	6,562 feet (2 km) 6,562 feet (2 km)
100BASE-FX (GLC-FE-100FX)	1310	MMF	50/125 62.5/125	500 500	6,562 feet (2 km) 6,562 feet (2 km)
100BASE-LX (100BASE-LX10)	1310	SMF	G.652 <sup>2</sup>	—	32,810 feet (10 km)
1000BASE-BX10-D (GLC-BX-D)	1490 TX 1310 RX	SMF	G.652 <sup>2</sup>	—	32,810 feet (10 km)
1000BASE-BX10-U (GLC-BX-U)	1310 TX 1490 RX	SMF	G.652 <sup>2</sup>	—	32,810 feet (10 km)
1000BASE-SX (GLC-SX-MM)	850	MMF	62.5/125 62.5/125 50/125 50/125	160 200 400 500	722 feet (220 m) 902 feet (275 m) 1640 feet (500 m) 1804 feet (550 m)
1000BASE-LX/LH (GLC-LH-SM)	1310	MMF <sup>3</sup>  SMF	62.5/125 50/125 50/125 G.652 <sup>2</sup>	500 400 500 —	1804 feet (550 m) 1804 feet (550 m) 1804 feet (550 m) 32,810 feet (10 km)
1000BASE-ZX (GLC-ZX-SM)	1550	SMF	G.652 <sup>2</sup>	—	43.4 to 62 miles (70 to 100 km) <sup>4</sup>
CWDM	1470, 1490, 1510, 1530, 1550, 1570, 1590, 1610	SMF	G.652 <sup>2</sup>	—	62 miles (100 km)

1. Modal bandwidth applies only to multimode fiber.
2. A mode-field diameter/cladding diameter = 9 micrometers/125 micrometers
3. A mode-conditioning patch cord is required. Using an ordinary patch cord with MMF, 1000BASE-LX/LH SFP modules, and a short link distance can cause transceiver saturation, resulting in an elevated bit error rate (BER). When using the LX/LH SFP module with 62.5-micron diameter MMF, you must also install a mode-conditioning patch cord between the SFP module and the MMF cable on both the sending and receiving ends of the link. The mode-conditioning patch cord is required for link distances greater than 984 feet (300 m).
4. 1000BASE-ZX SFP modules can send data up to 62 miles (100 km) by using dispersion-shifted SMF or low-attenuation SMF; the distance depends on the fiber quality, the number of splices, and the connectors.

## Two Twisted-Pair Cable Pinouts

Figure B-5 and Figure B-6 show the schematics of two twisted-pair cables for connecting to 10BASE-T- and 100BASE-TX-compatible devices.

**Figure B-5** Two Twisted-Pair Straight-Through Cable Schematic

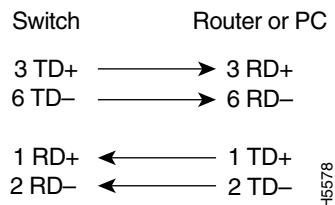

**Figure B-6** Two Twisted-Pair Crossover Cable Schematic

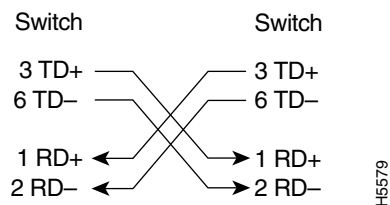

## Four Twisted-Pair Cable Pinouts for 1000BASE-T Ports

Figure B-7 and Figure B-8 show the schematics of four twisted-pair cables for 10/100/1000 ports on Catalyst 2960 switches.

**Figure B-7** Four Twisted-Pair Straight-Through Cable Schematic for 10/100/1000 Ports

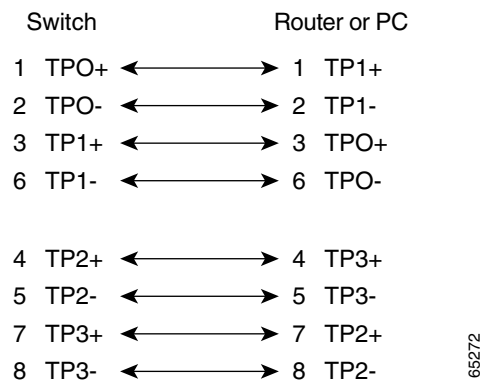

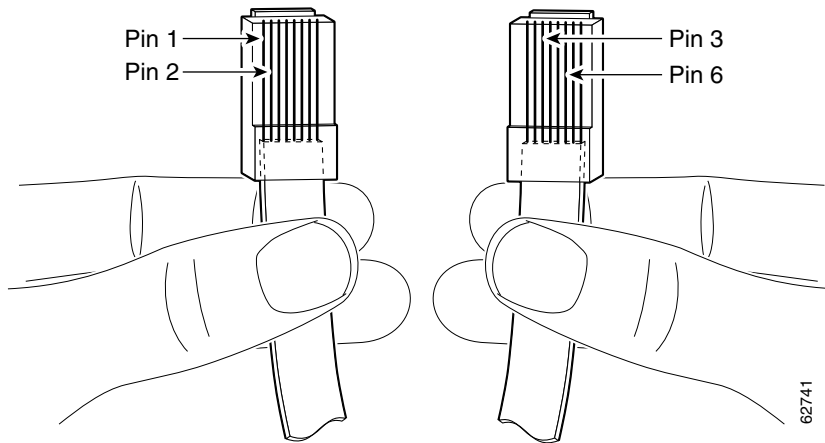

**Figure B-10 RJ-45 Crossover Cable Identification**

## Adapter Pinouts

Table B-2 lists the pinouts for the console port, the RJ-45-to-DB-9 adapter cable, and the console device.

**Table B-2 Console Port Signaling Using a DB-9 Adapter**

Switch Console Port (DTE)	RJ-45-to-DB-9 Terminal Adapter	Console Device
Signal	DB-9 Pin	Signal
RTS	8	CTS
DTR	6	DSR
TxD	2	RxD
GND	5	GND
GND	5	GND
RxD	3	TxD
DSR	4	DTR
CTS	7	RTS

Table B-3 lists the pinouts for the console port, RJ-45-to-DB-25 female DTE adapter, and the console device.



### Note

The RJ-45-to-DB-25 female DTE adapter is not supplied with the switch. You can order a kit (part number ACS-DSBUASYN=) containing this adapter from Cisco.

**Table B-3 Console Port Signaling Using a DB-25 Adapter**

<b>Switch Console Port (DTE)</b>	<b>RJ-45-to-DB-25 Terminal Adapter</b>	<b>Console Device</b>
<b>Signal</b>	<b>DB-25 Pin</b>	<b>Signal</b>
RTS	5	CTS
DTR	6	DSR
TxD	3	RxD
GND	7	GND
GND	7	GND
RxD	2	TxD
DSR	20	DTR
CTS	4	RTS

