



# Catalyst 2950 Desktop Switch Hardware Installation Guide

May 2003

Corporate Headquarters  
Cisco Systems, Inc.  
170 West Tasman Drive  
San Jose, CA 95134-1706  
USA  
<http://www.cisco.com>  
Tel: 408 526-4000  
800 553-NETS (6387)  
Fax: 408 526-4100

Customer Order Number: DOC-7811157=  
Text Part Number: 78-11157-05



THE SPECIFICATIONS AND INFORMATION REGARDING THE PRODUCTS IN THIS MANUAL ARE SUBJECT TO CHANGE WITHOUT NOTICE. ALL STATEMENTS, INFORMATION, AND RECOMMENDATIONS IN THIS MANUAL ARE BELIEVED TO BE ACCURATE BUT ARE PRESENTED WITHOUT WARRANTY OF ANY KIND, EXPRESS OR IMPLIED. USERS MUST TAKE FULL RESPONSIBILITY FOR THEIR APPLICATION OF ANY PRODUCTS.

THE SOFTWARE LICENSE AND LIMITED WARRANTY FOR THE ACCOMPANYING PRODUCT ARE SET FORTH IN THE INFORMATION PACKET THAT SHIPPED WITH THE PRODUCT AND ARE INCORPORATED HEREIN BY THIS REFERENCE. IF YOU ARE UNABLE TO LOCATE THE SOFTWARE LICENSE OR LIMITED WARRANTY, CONTACT YOUR CISCO REPRESENTATIVE FOR A COPY.

The following information is for FCC compliance of Class A devices: This equipment has been tested and found to comply with the limits for a Class A digital device, pursuant to part 15 of the FCC rules. These limits are designed to provide reasonable protection against harmful interference when the equipment is operated in a commercial environment. This equipment generates, uses, and can radiate radio-frequency energy and, if not installed and used in accordance with the instruction manual, may cause harmful interference to radio communications. Operation of this equipment in a residential area is likely to cause harmful interference, in which case users will be required to correct the interference at their own expense.

The following information is for FCC compliance of Class B devices: The equipment described in this manual generates and may radiate radio-frequency energy. If it is not installed in accordance with Cisco's installation instructions, it may cause interference with radio and television reception. This equipment has been tested and found to comply with the limits for a Class B digital device in accordance with the specifications in part 15 of the FCC rules. These specifications are designed to provide reasonable protection against such interference in a residential installation. However, there is no guarantee that interference will not occur in a particular installation.

Modifying the equipment without Cisco's written authorization may result in the equipment no longer complying with FCC requirements for Class A or Class B digital devices. In that event, your right to use the equipment may be limited by FCC regulations, and you may be required to correct any interference to radio or television communications at your own expense.

You can determine whether your equipment is causing interference by turning it off. If the interference stops, it was probably caused by the Cisco equipment or one of its peripheral devices. If the equipment causes interference to radio or television reception, try to correct the interference by using one or more of the following measures:

- Turn the television or radio antenna until the interference stops.
- Move the equipment to one side or the other of the television or radio.
- Move the equipment farther away from the television or radio.
- Plug the equipment into an outlet that is on a different circuit from the television or radio. (That is, make certain the equipment and the television or radio are on circuits controlled by different circuit breakers or fuses.)

Modifications to this product not authorized by Cisco Systems, Inc. could void the FCC approval and negate your authority to operate the product.

The Cisco implementation of TCP header compression is an adaptation of a program developed by the University of California, Berkeley (UCB) as part of UCB's public domain version of the UNIX operating system. All rights reserved. Copyright © 1981, Regents of the University of California.

NOTWITHSTANDING ANY OTHER WARRANTY HEREIN, ALL DOCUMENT FILES AND SOFTWARE OF THESE SUPPLIERS ARE PROVIDED "AS IS" WITH ALL FAULTS. CISCO AND THE ABOVE-NAMED SUPPLIERS DISCLAIM ALL WARRANTIES, EXPRESSED OR IMPLIED, INCLUDING, WITHOUT LIMITATION, THOSE OF MERCHANTABILITY, FITNESS FOR A PARTICULAR PURPOSE AND NONINFRINGEMENT OR ARISING FROM A COURSE OF DEALING, USAGE, OR TRADE PRACTICE.

IN NO EVENT SHALL CISCO OR ITS SUPPLIERS BE LIABLE FOR ANY INDIRECT, SPECIAL, CONSEQUENTIAL, OR INCIDENTAL DAMAGES, INCLUDING, WITHOUT LIMITATION, LOST PROFITS OR LOSS OR DAMAGE TO DATA ARISING OUT OF THE USE OR INABILITY TO USE THIS MANUAL, EVEN IF CISCO OR ITS SUPPLIERS HAVE BEEN ADVISED OF THE POSSIBILITY OF SUCH DAMAGES.

CCIP, CCSP, the Cisco Arrow logo, the Cisco *Powered* Network mark, Cisco Unity, Follow Me Browsing, FormShare, and StackWise are trademarks of Cisco Systems, Inc.; Changing the Way We Work, Live, Play, and Learn, and iQuick Study are service marks of Cisco Systems, Inc.; and Aironet, ASIST, BPX, Catalyst, CCDA, CCDP, CCIE, CCNA, CCNP, Cisco, the Cisco Certified Internetwork Expert logo, Cisco IOS, the Cisco IOS logo, Cisco Press, Cisco Systems, Cisco Systems Capital, the Cisco Systems logo, Empowering the Internet Generation, Enterprise/Solver, EtherChannel, EtherSwitch, Fast Step, GigaStack, Internet Quotient, IOS, IP/TV, iQ Expertise, the iQ logo, iQ Net Readiness Scorecard, LightStream, MGX, MICA, the Networkers logo, Networking Academy, Network Registrar, *Packet*, PIX, Post-Routing, Pre-Routing, RateMUX, Registrar, ScriptShare, SlideCast, SMARTnet, StrataView Plus, Stratm, SwitchProbe, TeleRouter, The Fastest Way to Increase Your Internet Quotient, TransPath, and VCO are registered trademarks of Cisco Systems, Inc. and/or its affiliates in the U.S. and certain other countries.

All other trademarks mentioned in this document or Web site are the property of their respective owners. The use of the word partner does not imply a partnership relationship between Cisco and any other company. (0304R)

*Catalyst 2950 Desktop Switch Hardware Installation Guide*

Copyright © 2001–2003, Cisco Systems, Inc.

All rights reserved.





## **Cisco Limited Lifetime Hardware Warranty Terms** xi

### **Preface** xv

Audience xv

Purpose xv

Conventions xvi

Related Publications xxiii

Obtaining Documentation xxv

    Cisco.com xxv

    Documentation CD-ROM xxvi

    Ordering Documentation xxvi

    Documentation Feedback xxvi

Obtaining Technical Assistance xxvii

    Cisco.com xxvii

    Technical Assistance Center xxviii

        Cisco TAC Website xxviii

        Cisco TAC Escalation Center xxix

Obtaining Additional Publications and Information xxix

---

## CHAPTER 1

### **Quick Installation** 1-1

Taking Out What You Need 1-2

Connecting to the Console Port 1-3

Starting the Terminal Emulation Software 1-4

Connecting to a Power Source 1-5

- Entering the Initial Configuration Information 1-6
  - IP Settings 1-6
  - Completing the Setup Program 1-6
- Connecting to an Ethernet Port 1-10
- Accessing the Switch from Your Browser 1-11
  - Recommended Platform Configuration for Web-Based Management 1-12
  - Operating System and Browser Support 1-12
  - Guidelines for Installing and Enabling the Java Plug-In 1-13
  - Installing the Required Java Plug-In 1-14

CHAPTER 2

**Overview 2-1**

- Features 2-1
- Front-Panel Description 2-4
  - 10/100 Ports 2-9
  - 10/100/1000 Ports 2-10
  - 100BASE-FX and 1000BASE-SX Ports 2-11
  - LRE Port 2-12
  - GBIC Module Ports 2-13
  - SFP Module Slots 2-14
    - SFP Modules 2-15
  - LEDs 2-17
    - System LED 2-20
    - RPS LED 2-21
    - Port Mode and Port Status LEDs 2-21
- Rear-Panel Description 2-27
  - Power Connectors 2-29
    - Internal Power Supply Connector 2-29
    - DC Power Connector 2-30
    - Cisco RPS Connector 2-30

Console Port	2-31
Management Options	2-32

---

**CHAPTER 3**

<b>Installation</b>	<b>3-1</b>
Preparing for Installation	3-2
Warnings	3-2
EMC Regulatory Statements	3-4
U.S.A.	3-4
Taiwan	3-5
Japan	3-5
Korea	3-6
Hungary	3-6
Installation Guidelines	3-7
Verifying Package Contents	3-8
Verifying Switch Operation	3-10
Installing the Switch in a Rack	3-10
Attaching the Brackets to the Switch	3-11
Mounting the Switch in a Rack	3-21
Attaching the Optional Cable Guide	3-22
Installing the Switch on a Table, Shelf, or Desk	3-22
Installing the Switch on a Wall	3-23
Attaching the Brackets to the Switch	3-23
Attaching the RPS Connector Cover	3-24
Mounting the Switch to a Wall	3-25
Installing the GBIC Modules	3-26
Installing and Removing SFP Modules	3-28
Installing SFP Modules into SFP Module Slots	3-28
Removing SFP Modules from SFP Module Slots	3-30
Connecting to 10/100 and 10/100/1000 Ports	3-32

- Connecting to 100BASE-FX and 1000BASE-SX Ports 3-36
- Connecting to an LRE Port 3-38
  - Connection Guidelines 3-38
  - Limitations and Restrictions with POTS Splitters 3-39
  - Required Cables 3-40
  - Connecting to a Patch Panel or POTS Splitter 3-41
- Connecting to GBIC Module Ports 3-44
  - Connecting to 1000BASE-X GBIC Module Ports 3-45
  - Connecting to 1000BASE-T GBIC Module Ports 3-47
  - Connecting to GigaStack GBIC Module Ports 3-48
- Connecting to an SFP Module 3-49
- Where to Go Next 3-50

---

CHAPTER 4

- Troubleshooting 4-1**
  - Understanding POST Results 4-2
  - Diagnosing Problems 4-2

---

APPENDIX A

- Technical Specifications A-1**

---

APPENDIX B

- Connectors and Cables B-1**
  - Connector Specifications B-1
    - 10/100 Ports B-2
    - 10/100/1000 Ports B-3
      - Connecting to 10BASE-T and 100BASE-TX Devices B-4
      - Connecting to 1000BASE-T Devices B-4
  - LRE Port B-5
  - 100BASE-FX and 1000BASE-SX Ports B-6
  - 1000BASE-X GBIC Module Ports B-6
  - 1000BASE-T GBIC Module Ports B-7



GigaStack GBIC Module Ports **B-7**

SFP Module Ports **B-7**

Console Port **B-8**

Cable and Adapter Specifications **B-8**

Two Twisted-Pair Cable Pinouts **B-8**

Four Twisted-Pair Cable Pinouts for 10/100 Ports **B-9**

Four Twisted-Pair Cable Pinouts for 1000BASE-T Ports **B-10**

RJ-21 Cable Pinouts **B-11**

Rollover Cable and Adapter Pinouts **B-14**

Identifying a Rollover Cable **B-14**

Adapter Pinouts **B-15**

---

## APPENDIX C

**Connecting to DC Power** **C-1**

Preparing for Installation **C-2**

Grounding the Switch **C-2**

Wiring the DC-Input Power Source **C-5**

---

## APPENDIX D

**Translated Safety Warnings** **D-1**

Attaching the Cisco RPS (model PWR300-AC-RPS-N1) **D-1**

Attaching the Cisco RPS (model PWR675-AC-RPS-N1) **D-2**

Lightning Activity Warning **D-4**

Installation Warning **D-5**

Main Disconnecting Device **D-6**

Chassis Warning—Rack-Mounting and Servicing **D-8**

Overtemperature Warning **D-12**

No On/Off Switch Warning **D-14**

Grounded Equipment Warning **D-16**

Product Disposal Warning **D-17**

Ground Connection Warning D-18

Jewelry Removal Warning D-20

Stacking the Chassis Warning D-22

Switch Installation Warning D-23

Redundant Power Supply Connection Warning D-25

Installation Warning D-26

Class 1 Laser Product Warning D-27

Laser Beam Exposure Warning D-29

Laser Radiation Warning D-30

Catalyst 2950G-24-EI-DC Service Requirement D-31

Catalyst 2950ST-24 LRE 997 Service Requirement D-34

Restricted Area Warning D-36

Ethernet Cable Shielding in Offices D-38

Chassis Power Connection D-39

Exposed DC Power Wire Warning D-42

Service Personnel Warning D-44

---

INDEX



# Cisco Limited Lifetime Hardware Warranty Terms

---

There are special terms applicable to your hardware warranty and various services that you can use during the warranty period. Follow these steps to access and download the *Cisco Information Packet* and your warranty document from Cisco.com.

1. Launch your browser, and go to this URL:

[http://www.cisco.com/univercd/cc/td/doc/es\\_inpk/cetrans.htm](http://www.cisco.com/univercd/cc/td/doc/es_inpk/cetrans.htm)

The Warranties and License Agreements page appears.

2. To read the *Cisco Information Packet*, follow these steps:

- a. Click the **Information Packet Number** field, and make sure that the part number 78-5235-02F0 is highlighted.
- b. Select the language in which you would like to read the document.
- c. Click **Go**.

The Cisco Limited Warranty and Software License page from the Information Packet appears.

- d. Read the document online, or click the **PDF** icon to download and print the document in Adobe Portable Document Format (PDF).



---

#### Note

You must have Adobe Acrobat Reader to view and print PDF files. You can download the reader from Adobe's website:

<http://www.adobe.com>

---

3. To read translated and localized warranty information about your product, follow these steps:
  - a. Enter this part number in the Warranty Document Number field:  
78-6310-02C0
  - b. Select the language in which you would like to view the document.
  - c. Click **Go**.  
The Cisco warranty page appears.
  - d. Read the document online, or click the **PDF** icon to download and print the document in Adobe Portable Document Format (PDF).

You can also contact the Cisco service and support website for assistance:

[http://www.cisco.com/public/Support\\_root.shtml](http://www.cisco.com/public/Support_root.shtml).

#### **Duration of Hardware Warranty**

A Cisco product hardware warranty is supported for as long as the original end user continues to own or use the product, provided that the fan and power supply warranty is limited to five (5) years. In the event of a discontinuance of product manufacture, the Cisco warranty support is limited to five (5) years from the announcement of the discontinuance.

#### **Replacement, Repair, or Refund Policy for Hardware**

Cisco or its service center will use commercially reasonable efforts to ship a replacement part within ten (10) working days after receipt of the Return Materials Authorization (RMA) request. Actual delivery times can vary, depending on the customer location.

Cisco reserves the right to refund the purchase price as its exclusive warranty remedy.

#### **To Receive a Return Materials Authorization (RMA) Number**

Contact the company from whom you purchased the product. If you purchased the product directly from Cisco, contact your Cisco Sales and Service Representative.

Complete the information below, and keep it for reference.

Company product purchased from	
Company telephone number	
Product model number	
Product serial number	
Maintenance contract number	





## Preface

---

### Audience

This guide is for the networking or computer technician responsible for installing a Catalyst 2950 switch, hereafter referred to as the *switch*. We assume that you are familiar with the concepts and terminology of Ethernet and local area networking.

### Purpose

This guide describes the hardware features of the Catalyst 2950 switch. It describes the physical and performance characteristics of the switch, explains how to install a switch, and provides troubleshooting information and specifications.

This guide does not describe how to configure software features on your switch or describe the Catalyst 2950-specific system messages that you might encounter. It also does not provide information about command-line interface (CLI) commands that have been created or changed for use by the switch. For more information, refer to the switch software configuration guide, the switch system message guide, and the switch command reference.

# Conventions

Command descriptions use these conventions:

- Commands and keywords are in **boldface** text.
- Arguments for which you supply values are in *italic*.
- Square brackets ([ ]) mean optional elements.
- Braces ({ }) group required choices, and vertical bars (|) separate the alternative elements.
- Braces and vertical bars within square brackets ({ | }) mean a required choice within an optional element.

Notes, cautions, and warnings use these conventions and symbols:



Note

---

Means *reader take note*. Notes contain helpful suggestions or references to materials not contained in this manual.

---



Caution

---

Means *reader be careful*. In this situation, you might do something that could result in equipment damage or loss of data.

---



**Warning****IMPORTANT SAFETY INSTRUCTIONS**

This warning symbol means danger. You are in a situation that could cause bodily injury. Before you work on any equipment, be aware of the hazards involved with electrical circuitry and be familiar with standard practices for preventing accidents. To see translations of the warnings that appear in this publication, refer to the translated safety warnings that accompanied this device.

**Note: SAVE THESE INSTRUCTIONS**

**Note:** This documentation is to be used in conjunction with the specific product installation guide that shipped with the product. Please refer to the Installation Guide, Configuration Guide, or other enclosed additional documentation for further details.

**Waarschuwing****BELANGRIJKE VEILIGHEIDSINSTRUCTIES**

Dit waarschuwingssymbool betekent gevaar. U verkeert in een situatie die lichamelijk letsel kan veroorzaken. Voordat u aan enige apparatuur gaat werken, dient u zich bewust te zijn van de bij elektrische schakelingen betrokken risico's en dient u op de hoogte te zijn van de standaard praktijken om ongelukken te voorkomen. Voor een vertaling van de waarschuwingen die in deze publicatie verschijnen, dient u de vertaalde veiligheidswaarschuwingen te raadplegen die bij dit apparaat worden geleverd.

**Opmerking BEWAAR DEZE INSTRUCTIES.**

**Opmerking** Deze documentatie dient gebruikt te worden in combinatie met de installatiehandleiding voor het specifieke product die bij het product wordt geleverd. Raadpleeg de installatiehandleiding, configuratiehandleiding of andere verdere ingesloten documentatie voor meer informatie.

**Varoitus TÄRKEITÄ TURVALLISUUTEEN LIITTYVIÄ OHJEITA**

Tämä varoitusmerkki merkitsee vaaraa. Olet tilanteessa, joka voi johtaa ruumiinvammaan. Ennen kuin työskentelet minkään laitteiston parissa, ota selvää sähkökytkentöihin liittyvistä vaaroista ja tavanomaisista onnettomuuksien ehkäisykeinoista. Tässä asiakirjassa esitettyjen varoitusten käännökset löydät laitteen mukana toimitetuista ohjeista.

**Huomautus SÄILYTÄ NÄMÄ OHJEET**

Huomautus Tämä asiakirja on tarkoitettu käytettäväksi yhdessä tuotteen mukana tulleen asennusoppaan kanssa. Katso lisätietoja asennusoppaasta, kokoonpano-oppaasta ja muista mukana toimitetuista asiakirjoista.

**Attention IMPORTANTES INFORMATIONS DE SÉCURITÉ**

Ce symbole d'avertissement indique un danger. Vous vous trouvez dans une situation pouvant causer des blessures ou des dommages corporels. Avant de travailler sur un équipement, soyez conscient des dangers posés par les circuits électriques et familiarisez-vous avec les procédures couramment utilisées pour éviter les accidents. Pour prendre connaissance des traductions d'avertissements figurant dans cette publication, consultez les consignes de sécurité traduites qui accompagnent cet appareil.

**Remarque CONSERVEZ CES INFORMATIONS**

Remarque Cette documentation doit être utilisée avec le guide spécifique d'installation du produit qui accompagne ce dernier. Veuillez vous reporter au Guide d'installation, au Guide de configuration, ou à toute autre documentation jointe pour de plus amples renseignements.

**Warnung WICHTIGE SICHERHEITSANWEISUNGEN**

Dieses Warnsymbol bedeutet Gefahr. Sie befinden sich in einer Situation, die zu einer Körperverletzung führen könnte. Bevor Sie mit der Arbeit an irgendeinem Gerät beginnen, seien Sie sich der mit elektrischen Stromkreisen verbundenen Gefahren und der Standardpraktiken zur Vermeidung von Unfällen bewusst. Übersetzungen der in dieser Veröffentlichung enthaltenen Warnhinweise sind im Lieferumfang des Geräts enthalten.

**Hinweis BEWAHREN SIE DIESE SICHERHEITSANWEISUNGEN AUF**

Hinweis Dieses Handbuch ist zum Gebrauch in Verbindung mit dem Installationshandbuch für Ihr Gerät bestimmt, das dem Gerät beiliegt. Entnehmen Sie bitte alle weiteren Informationen dem Handbuch (Installations- oder Konfigurationshandbuch o. Ä.) für Ihr spezifisches Gerät.

**Figyelem! FONTOS BIZTONSÁGI ELŐÍRÁSOK**

Ez a figyelmeztető jel veszélyre utal. Sérülésveszélyt rejtő helyzetben van. Mielőtt bármely berendezésen munkát végezte, legyen figyelemmel az elektromos áramkörök okozta kockázatokra, és ismerkedjen meg a szokásos balesetvédelmi eljárásokkal. A kiadványban szereplő figyelmeztetések fordítása a készülékhez mellékelt biztonsági figyelmeztetések között található.

**Megjegyzés ŐRIZZE MEG EZEKET AZ UTASÍTÁSOKAT!**

Megjegyzés Ezt a dokumentációt a készülékhez mellékelt üzembe helyezési útmutatóval együtt kell használni. További tudnivalók a mellékelt Üzembe helyezési útmutatóban (Installation Guide), Konfigurációs útmutatóban (Configuration Guide) vagy más dokumentumban található.

**Avvertenza      IMPORTANTI ISTRUZIONI SULLA SICUREZZA**

Questo simbolo di avvertenza indica un pericolo. La situazione potrebbe causare infortuni alle persone. Prima di intervenire su qualsiasi apparecchiatura, occorre essere al corrente dei pericoli relativi ai circuiti elettrici e conoscere le procedure standard per la prevenzione di incidenti. Per le traduzioni delle avvertenze riportate in questo documento, vedere le avvertenze di sicurezza che accompagnano questo dispositivo.

**Nota      CONSERVARE QUESTE ISTRUZIONI**

Nota La presente documentazione va usata congiuntamente alla guida di installazione specifica spedita con il prodotto. Per maggiori informazioni, consultare la Guida all'installazione, la Guida alla configurazione o altra documentazione acclusa.

**Advarsel      VIKTIGE SIKKERHETSINSTRUKSJONER**

Dette varselssymbolet betyr fare. Du befinner deg i en situasjon som kan forårsake personskade. Før du utfører arbeid med utstyret, bør du være oppmerksom på farene som er forbundet med elektriske kretssystemer, og du bør være kjent med vanlig praksis for å unngå ulykker. For å se oversettelser av advarslene i denne publikasjonen, se de oversatte sikkerhetsvarslene som følger med denne enheten.

**Merk      TA VARE PÅ DISSE INSTRUKSJONENE**

Merk Denne dokumentasjonen skal brukes i forbindelse med den spesifikke installasjonsveiledningen som fulgte med produktet. Vennligst se installasjonsveiledningen, konfigureringsveiledningen eller annen vedlagt tilleggsdokumentasjon for detaljer.

**Aviso INSTRUÇÕES IMPORTANTES DE SEGURANÇA**

Este símbolo de aviso significa perigo. O utilizador encontra-se numa situação que poderá ser causadora de lesões corporais. Antes de iniciar a utilização de qualquer equipamento, tenha em atenção os perigos envolvidos no manuseamento de circuitos eléctricos e familiarize-se com as práticas habituais de prevenção de acidentes. Para ver traduções dos avisos incluídos nesta publicação, consulte os avisos de segurança traduzidos que acompanham este dispositivo.

**Nota GUARDE ESTAS INSTRUÇÕES**

Nota Esta documentação destina-se a ser utilizada em conjunto com o manual de instalação incluído com o produto específico. Consulte o manual de instalação, o manual de configuração ou outra documentação adicional inclusa, para obter mais informações.

**¡Advertencia! INSTRUCCIONES IMPORTANTES DE SEGURIDAD**

Este símbolo de aviso indica peligro. Existe riesgo para su integridad física. Antes de manipular cualquier equipo, considere los riesgos de la corriente eléctrica y familiarícese con los procedimientos estándar de prevención de accidentes. Vea las traducciones de las advertencias que acompañan a este dispositivo.

**Nota GUARDE ESTAS INSTRUCCIONES**

Nota Esta documentación está pensada para ser utilizada con la guía de instalación del producto que lo acompaña. Si necesita más detalles, consulte la Guía de instalación, la Guía de configuración o cualquier documentación adicional adjunta.

**Varning! VIKTIGA SÄKERHETSANVISNINGAR**

Denna varningssignal signalerar fara. Du befinner dig i en situation som kan leda till personskada. Innan du utför arbete på någon utrustning måste du vara medveten om farorna med elkretsar och känna till vanliga förfaranden för att förebygga olyckor. Se översättningarna av de varningsmeddelanden som finns i denna publikation, och se de översatta säkerhetsvarningarna som medföljer denna anordning.

**OBS! SPARA DESSA ANVISNINGAR**

**OBS!** Denna dokumentation ska användas i samband med den specifika produktinstallationshandbok som medföljde produkten. Se installationshandboken, konfigurationshandboken eller annan bifogad ytterligare dokumentation för närmare detaljer.

**Предупреждение ВАЖНЫЕ СВЕДЕНИЯ ПО БЕЗОПАСНОСТИ**

Этот символ предупреждает о наличии опасности. При неправильных действиях возможно получение травм. Перед началом работы с любым оборудованием необходимо ознакомиться с ситуациями, в которых возможно поражение электротоком, и со стандартными действиями для предотвращения несчастных случаев. Переведенный текст предупреждений содержится в соответствующем документе, поставляемом вместе с устройством.

Примечание **СОХРАНЯЙТЕ ЭТУ ИНСТРУКЦИЮ**

Примечание Эта инструкция должна использоваться вместе с руководством по установке конкретного изделия, входящим в комплект поставки. Дополнительные сведения см. в руководстве по установке, руководстве по настройке и другой документации, поставляемой с изделием.

**警告** 有关安全的重要说明

这个警告符号指有危险。您所处的环境可能使身体受伤。操作设备前必须意识到电流的危险性，务必熟悉操作标准，以防发生事故。如果需要了解本说明中出现的警告符号的译文，请参阅本装置所附之安全警告译文。

注意 保存这些说明

注意 本文件应与本产品附带的具体安装说明一并阅读。如欲了解详情，请参阅《安装说明》、《配置说明》或所附的其他文件。

**警告** 安全上の重要な注意事項

「危険」の意味です。人身事故を予防するための注意事項が記述されています。装置の取り扱い作業を行うときは、電気回路の危険性に注意し、一般的な事故防止対策に留意してください。このマニュアルに記載されている警告の各国語版は、装置に付属の「Translated Safety Warnings」を参照してください。

注 これらの注意事項を保管しておいてください。

注 この資料は、製品に付属のインストレーション ガイドと併用してください。詳細は、インストレーション ガイド、コンフィギュレーション ガイド、または添付されているその他のマニュアルを参照してください。

## Related Publications

These documents provide complete information about the switch and are available from this URL:

<http://www.cisco.com/univercd/cc/td/doc/product/lan/cat2950/index.htm>

You can order printed copies of documents with a DOC-xxxxxx= number from the Cisco.com sites and from the telephone numbers listed in the “[Ordering Documentation](#)” section on page xxvi.

- *Release Notes for the Catalyst 2950 and Catalyst 2955 Switches* (not orderable but is available on Cisco.com)
- *Release Notes for the Catalyst 2950 LRE Switches* (not orderable but is available on Cisco.com)

**Note**

---

Switch requirements and procedures for initial configurations and software upgrades tend to change and therefore appear only in the release notes. Before installing, configuring, or upgrading the switch, refer to the release notes on Cisco.com for the latest information.

---

For hardware information about the switch, refer to the *Catalyst 2950 Desktop Switch Hardware Installation Guide* (order number DOC-7811157=)

For software information about the switch, refer to these documents:

- *Catalyst 2950 and Catalyst 2955 Switch Software Configuration Guide* (order number DOC-7811380=)
- *Catalyst 2950 and Catalyst 2955 Switch Command Reference* (order number DOC-7811381=)
- *Catalyst 2950 and Catalyst 2955 Switch System Message Guide* (order number DOC-7814233=)

For information about the Catalyst 2950 Long-Reach Ethernet (LRE) switches, refer to these documents:

- *Catalyst 2950 Desktop Switch Software Configuration Guide* (order number DOC-7814982=)
- *Catalyst 2950 Desktop Switch Command Reference* (order number DOC-7814984=)
- *Catalyst 2950 Desktop Switch System Message Guide* (order number DOC-7814981=)
- *Release Notes for the Catalyst 2950 LRE Switch* (not orderable but available on Cisco.com)

For other information about related products, refer to these documents:

- *1000BASE-T Gigabit Interface Converter Installation Notes* (not orderable but is available on Cisco.com)
- *Catalyst GigaStack Gigabit Interface Converter Hardware Installation Guide* (order number DOC-786460=)
- *Cisco LRE CPE Hardware Installation Guide* (order number DOC-7811469=)
- *Cisco RPS 300 Redundant Power System Hardware Installation Guide* (order number DOC-7810372=)



- *Cisco RPS 675 Redundant Power System Hardware Installation Guide* (order number DOC-7815201=)
- Cluster Management Suite (CMS) online help (available only from the switch CMS software)
- *Course Wave Division Multiplexer (CWDM) Passive Optical System Installation Note* (not orderable but is available on Cisco.com)
- *Installation Notes for the Catalyst Family Small-Form-Factor Pluggable Modules* (order number DOC-7815160=)
- *Installation and Warranty Notes for the Cisco LRE 48 POTS Splitter* (order number DOC-7812250=)
- *Installation Notes for Wall-Mount Brackets* (order number DOC-7813035=)

## Obtaining Documentation

Cisco provides several ways to obtain documentation, technical assistance, and other technical resources. These sections explain how to obtain technical information from Cisco Systems.

### Cisco.com

You can access the most current Cisco documentation on the World Wide Web at this URL:

<http://www.cisco.com/univercd/home/home.htm>

You can access the Cisco website at this URL:

<http://www.cisco.com>

You can access international Cisco websites from this URL:

[http://www.cisco.com/public/countries\\_languages.shtml](http://www.cisco.com/public/countries_languages.shtml)

## Documentation CD-ROM

Cisco documentation and additional literature are available in a Cisco Documentation CD-ROM package, which may have shipped with your product. The Documentation CD-ROM is updated monthly and may be more current than printed documentation. The CD-ROM package is available as a single unit or through an annual subscription.

Registered Cisco.com users can order the Documentation CD-ROM (product number DOC-CONDOCCD=) through the online Subscription Store:

<http://www.cisco.com/go/subscription>

## Ordering Documentation

You can find instructions for ordering documentation at this URL:

[http://www.cisco.com/univercd/cc/td/doc/es\\_inpk/pdi.htm](http://www.cisco.com/univercd/cc/td/doc/es_inpk/pdi.htm)

You can order Cisco documentation in these ways:

- Registered Cisco.com users (Cisco direct customers) can order Cisco product documentation from the Networking Products MarketPlace:

<http://www.cisco.com/en/US/partner/ordering/index.shtml>

- Registered Cisco.com users can order the Documentation CD-ROM (Customer Order Number DOC-CONDOCCD=) through the online Subscription Store:

<http://www.cisco.com/go/subscription>

- Nonregistered Cisco.com users can order documentation through a local account representative by calling Cisco Systems Corporate Headquarters (California, U.S.A.) at 408 526-7208 or, elsewhere in North America, by calling 800 553-NETS (6387).

## Documentation Feedback

You can submit comments electronically on Cisco.com. On the Cisco Documentation home page, click **Feedback** at the top of the page.

You can e-mail your comments to [bug-doc@cisco.com](mailto:bug-doc@cisco.com).

You can submit your comments by mail by using the response card behind the front cover of your document or by writing to the following address:

Cisco Systems  
Attn: Customer Document Ordering  
170 West Tasman Drive  
San Jose, CA 95134-9883

We appreciate your comments.

## Obtaining Technical Assistance

Cisco provides Cisco.com, which includes the Cisco Technical Assistance Center (TAC) Website, as a starting point for all technical assistance. Customers and partners can obtain online documentation, troubleshooting tips, and sample configurations from the Cisco TAC website. Cisco.com registered users have complete access to the technical support resources on the Cisco TAC website, including TAC tools and utilities.

### Cisco.com

Cisco.com offers a suite of interactive, networked services that let you access Cisco information, networking solutions, services, programs, and resources at any time, from anywhere in the world.

Cisco.com provides a broad range of features and services to help you with these tasks:

- Streamline business processes and improve productivity
- Resolve technical issues with online support
- Download and test software packages
- Order Cisco learning materials and merchandise
- Register for online skill assessment, training, and certification programs

To obtain customized information and service, you can self-register on Cisco.com at this URL:

<http://www.cisco.com>

## Technical Assistance Center

The Cisco TAC is available to all customers who need technical assistance with a Cisco product, technology, or solution. Two levels of support are available: the Cisco TAC website and the Cisco TAC Escalation Center. The avenue of support that you choose depends on the priority of the problem and the conditions stated in service contracts, when applicable.

We categorize Cisco TAC inquiries according to urgency:

- Priority level 4 (P4)—You need information or assistance concerning Cisco product capabilities, product installation, or basic product configuration.
- Priority level 3 (P3)—Your network performance is degraded. Network functionality is noticeably impaired, but most business operations continue.
- Priority level 2 (P2)—Your production network is severely degraded, affecting significant aspects of business operations. No workaround is available.
- Priority level 1 (P1)—Your production network is down, and a critical impact to business operations will occur if service is not restored quickly. No workaround is available.

## Cisco TAC Website

You can use the Cisco TAC website to resolve P3 and P4 issues yourself, saving both cost and time. The site provides around-the-clock access to online tools, knowledge bases, and software. To access the Cisco TAC website, go to this URL:

<http://www.cisco.com/tac>

All customers, partners, and resellers who have a valid Cisco service contract have complete access to the technical support resources on the Cisco TAC website. Some services on the Cisco TAC website require a Cisco.com login ID and password. If you have a valid service contract but do not have a login ID or password, go to this URL to register:

<http://tools.cisco.com/RPF/register/register.do>

If you are a Cisco.com registered user, and you cannot resolve your technical issues by using the Cisco TAC website, you can open a case online at this URL:

<http://www.cisco.com/en/US/support/index.html>

If you have Internet access, we recommend that you open P3 and P4 cases through the Cisco TAC website so that you can describe the situation in your own words and attach any necessary files.

## Cisco TAC Escalation Center

The Cisco TAC Escalation Center addresses priority level 1 or priority level 2 issues. These classifications are assigned when severe network degradation significantly impacts business operations. When you contact the TAC Escalation Center with a P1 or P2 problem, a Cisco TAC engineer automatically opens a case.

To obtain a directory of toll-free Cisco TAC telephone numbers for your country, go to this URL:

<http://www.cisco.com/warp/public/687/Directory/DirTAC.shtml>

Before calling, please check with your network operations center to determine the level of Cisco support services to which your company is entitled: for example, SMARTnet, SMARTnet Onsite, or Network Supported Accounts (NSA). When you call the center, please have available your service agreement number and your product serial number.

## Obtaining Additional Publications and Information

Information about Cisco products, technologies, and network solutions is available from various online and printed sources.

- The *Cisco Product Catalog* describes the networking products offered by Cisco Systems as well as ordering and customer support services. Access the *Cisco Product Catalog* at this URL:

[http://www.cisco.com/en/US/products/products\\_catalog\\_links\\_launch.html](http://www.cisco.com/en/US/products/products_catalog_links_launch.html)

- Cisco Press publishes a wide range of networking publications. Cisco suggests these titles for new and experienced users: *Internetworking Terms and Acronyms Dictionary*, *Internetworking Technology Handbook*, *Internetworking Troubleshooting Guide*, and the *Internetworking Design Guide*. For current Cisco Press titles and other information, go to Cisco Press online at this URL:

<http://www.ciscopress.com>

- *Packet* magazine is the Cisco monthly periodical that provides industry professionals with the latest information about the field of networking. You can access *Packet* magazine at this URL:  
[http://www.cisco.com/en/US/about/ac123/ac114/about\\_cisco\\_packet\\_magazine.html](http://www.cisco.com/en/US/about/ac123/ac114/about_cisco_packet_magazine.html)
- *iQ Magazine* is the Cisco monthly periodical that provides business leaders and decision makers with the latest information about the networking industry. You can access *iQ Magazine* at this URL:  
[http://business.cisco.com/prod/tree.taf%3fasset\\_id=44699&public\\_view=true&kbns=1.html](http://business.cisco.com/prod/tree.taf%3fasset_id=44699&public_view=true&kbns=1.html)
- *Internet Protocol Journal* is a quarterly journal published by Cisco Systems for engineering professionals involved in the design, development, and operation of public and private internets and intranets. You can access the *Internet Protocol Journal* at this URL:  
[http://www.cisco.com/en/US/about/ac123/ac147/about\\_cisco\\_the\\_internet\\_protocol\\_journal.html](http://www.cisco.com/en/US/about/ac123/ac147/about_cisco_the_internet_protocol_journal.html)
- Training—Cisco offers world-class networking training, with current offerings in network training listed at this URL:  
[http://www.cisco.com/en/US/learning/1e31/learning\\_recommended\\_training\\_list.html](http://www.cisco.com/en/US/learning/1e31/learning_recommended_training_list.html)



# Quick Installation

---

This chapter provides a quick step-by-step installation and setup procedure for a standalone switch.



## Note

---

For detailed installation procedures on rack-mounting your switch, connecting to the Gigabit Ethernet Interface Converter (GBIC) modules, or connecting to the small form-factor pluggable (SFP) modules, see [Chapter 3, “Installation.”](#) For product overview information, see [Chapter 2, “Overview.”](#)

---

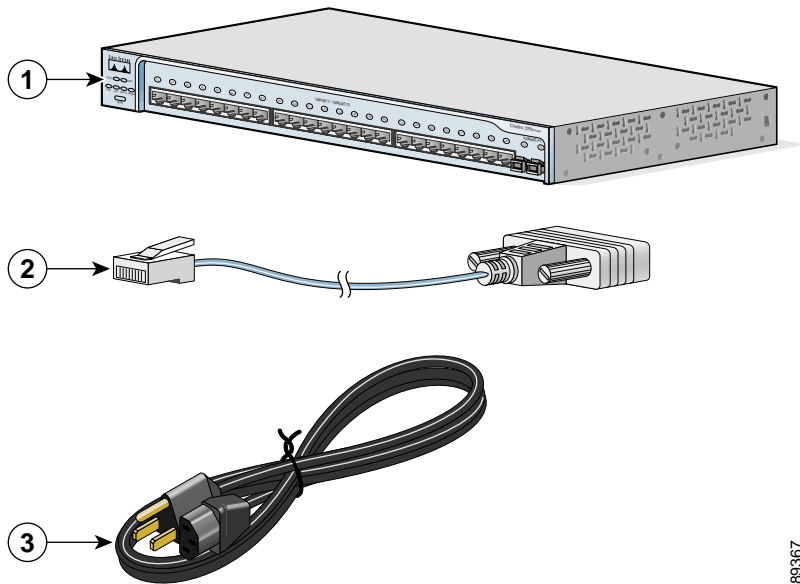
These steps describe how to do a simple installation:

1. [Taking Out What You Need, page 1-2](#)
2. [Connecting to the Console Port, page 1-3](#)
3. [Starting the Terminal Emulation Software, page 1-4](#)
4. [Connecting to a Power Source, page 1-5](#)
5. [Entering the Initial Configuration Information, page 1-6](#)
6. [Connecting to an Ethernet Port, page 1-10](#)
7. [Accessing the Switch from Your Browser, page 1-11](#)

# Taking Out What You Need

Remove the items shown in [Figure 1-1](#) from the shipping container:

**Figure 1-1** Catalyst 2950 Switch, Adapter Cable, and AC Power Cord



1	Catalyst 2950 switch
2	RJ-45-to-DB-9 adapter cable
3	AC power cord



## Note

You need to provide the Category 5 straight-through cables to connect the switch ports to other Ethernet devices.

89367



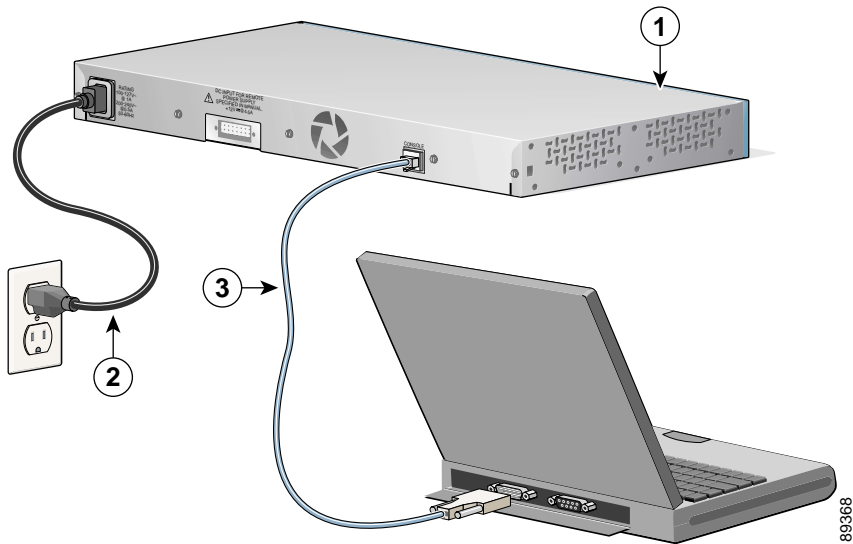
# Connecting to the Console Port

You can use the console port to perform the initial configuration. To connect the switch console port to a PC, use the supplied RJ-45-to-DB-9 adapter cable.

Follow these steps to connect the PC or terminal to the switch:

- 
- Step 1** Using the supplied RJ-45-to-DB-9 adapter cable, insert the RJ-45 connector into the console port on the rear of a switch, as shown in [Figure 1-2](#).
- Step 2** Attach the DB-9 female DTE of the adapter cable to a PC serial port, or attach an appropriate adapter to the terminal.
- 

**Figure 1-2** Connecting a Switch to a PC



1	Catalyst 2950 switch
2	Power cord
3	RJ-45-to-DB-9 adapter cable

# Starting the Terminal Emulation Software

Before you power on the switch, start the terminal-emulation session so that you can see the output display from the power-on self-test (POST).

The terminal-emulation software—frequently a PC application such as Hyperterminal or ProcommPlus—makes communication between the switch and your PC or terminal possible.

Follow these steps to start a terminal-emulation session:

- 
- Step 1** Start the terminal-emulation program if you are using a PC or terminal.
- Step 2** Start a terminal-emulation session.
- Step 3** Configure the baud rate and character format of the PC or terminal to match these console port default characteristics:
- 9600 baud
  - 8 data bits
  - 1 stop bit
  - No parity
  - None (flow control)
-

# Connecting to a Power Source

**Note**

---

For instructions about connecting the Catalyst 2950G-24-EI-DC or Catalyst 2950ST-24 LRE 997 switch to direct current (DC) power, see [Appendix C, “Connecting to DC Power.”](#)

---

For a switch other than a Catalyst 2950G-24-EI-DC and Catalyst 2950ST-24 LRE 997 switch, follow these steps to connect to a power source:

- 
- Step 1** For a switch other than a Catalyst 2950 Long-Reach Ethernet (LRE) switch, connect one end of the supplied AC power cord to the power connector on a switch rear panel. For an LRE switch, connect one end of the supplied AC power cord to the power connector on a switch front panel.

[Figure 1-2](#) shows how to connect the AC power cord to the connector on a switch rear panel.

- Step 2** Connect the other end of the power cable to a grounded AC outlet.

**Note**

---

If you are connecting the switch to a Cisco redundant power system (RPS), refer to the documentation that shipped with your RPS.

---

As the switch powers on, it begins the power-on self-test (POST), a series of tests that runs automatically to ensure that the switch functions properly. If POST fails, see [Chapter 4, “Troubleshooting,”](#) to determine a course of action.

---

If you started the terminal-emulation program before you powered on your switch, the PC or terminal displays the bootloader sequence. You need to press **Enter** to display the setup program prompt.

# Entering the Initial Configuration Information

To set up the switch, you need to complete the setup program, which runs automatically after the switch is powered up. You must assign an IP address and other configuration information necessary for the switch to communicate with the local routers and the Internet. This information is also required if you plan to use the Cluster Management Suite (CMS) to configure and manage the switch.

## IP Settings

You will need this information from your network administrator before you complete the setup program:

- Switch IP address
- Subnet mask (IP netmask)
- Default gateway (router)
- Enable secret password
- Enable password
- Telnet password

## Completing the Setup Program

Follow these steps to complete the setup program and to create an initial configuration for the switch:

---

**Step 1** Enter **Yes** at these two prompts.

```
Would you like to enter the initial configuration dialog? [yes/no]:  
yes
```

```
At any point you may enter a question mark '?' for help.  
Use ctrl-c to abort configuration dialog at any prompt.  
Default settings are in square brackets '['].
```

Basic management setup configures only enough connectivity for management of the system, extended setup will ask you to configure each interface on the system.

Would you like to enter basic management setup? [yes/no]: **yes**

**Step 2** Enter a host name for the switch, and press **Return**.

On a command switch, the host name is limited to 28 characters; on a member switch to 31 characters. Do not use *-n*, where *n* is a number, as the last character in a host name for any switch.

Enter host name [Switch]: *host\_name*

**Step 3** Enter an enable secret password, and press **Return**.

The password can be from 1 to 25 alphanumeric characters, can start with a number, is case sensitive, allows spaces, but ignores leading spaces. The secret password is encrypted, and the enable password is in plain text.

Enter enable secret: *secret\_password*

**Step 4** Enter an enable password, and press **Return**.

Enter enable password: *enable\_password*

**Step 5** Enter a virtual terminal (Telnet) password, and press **Return**.

The password can be from 1 to 25 alphanumeric characters, is case sensitive, allows spaces, but ignores leading spaces.

Enter virtual terminal password: *terminal-password*

**Step 6** (Optional) Configure Simple Network Management Protocol (SNMP) by responding to the prompts. You can also configure SNMP later through the command-line interface (CLI) or Cluster Management Suite (CMS) interface. To configure SNMP later, enter **no**.

Configure SNMP Network Management? [no]: **no**

**Step 7** Enter the interface name (physical interface or virtual local-area network [VLAN] name) of the interface that connects to the management network, and press **Return**. For this release, always use *vlan1* as that interface.

Enter interface name used to connect to the management network from the above interface summary: **vlan1**

- Step 8** Configure the interface by entering the switch IP address and subnet mask and pressing **Return**. The IP address and subnet masks shown below are examples.

```
Configuring interface vlan1:
Configure IP on this interface? [yes]: yes
IP address for this interface: 10.4.120.106
Subnet mask for this interface [255.0.0.0]: 255.0.0.0
```

- Step 9** Enter **Y** to configure the switch as the cluster command switch. Enter **N** to configure it as a member switch or as a standalone switch.

If you enter **N**, the switch appears as a candidate switch in the CMS. You can configure the switch as a command switch later through the CLI or CMS interface. To configure it later, type **no**.

```
Would you like to enable as a cluster command switch? [yes/no]: no
```

You have now completed the initial configuration of the switch, and the switch displays that configuration. This is an example of the output that appears:

```
The following configuration command script was created:
hostname host_name
enable secret 5 $1$Max7$Qgr9eXBhtcBJw3KK7bc850
enable password my
line vty 0 15
password my_password
snmp-server community public
!
no ip routing
!
interface Vlan1
no shutdown
ip address 172.20.139.145 255.255.255.224
!
interface Vlan2
shutdown
no ip address
!
interface FastEthernet0/1
!
interface FastEthernet0/2
!
...<output abbreviated>
!!!
interface GigabitEthernet0/1
!
```

```
interface GigabitEthernet0/2
!
end
```

**Step 10** These choices appear:

- [0] Go to the IOS command prompt without saving this config.
- [1] Return back to the setup without saving this config.
- [2] Save this configuration to nvram and exit.

If you want to save the configuration and use it the next time the switch reboots, save it in nonvolatile RAM (NVRAM) by selecting option 2.

Enter your selection [2]:2

Make your selection, and press **Return**.

---

After you complete the setup program, the switch can run the default configuration that you created. If you want to change this configuration or want to perform other management tasks, use one of these tools:

- CLI
- CMS from your browser

To use the CLI, enter commands at the *Switch>* prompt through the console port by using a terminal program or through the network by using Telnet. For configuration information, refer to the switch software configuration guide or the switch command reference.

To use the CMS, go to [“Accessing the Switch from Your Browser”](#) section on page 1-11.

# Connecting to an Ethernet Port

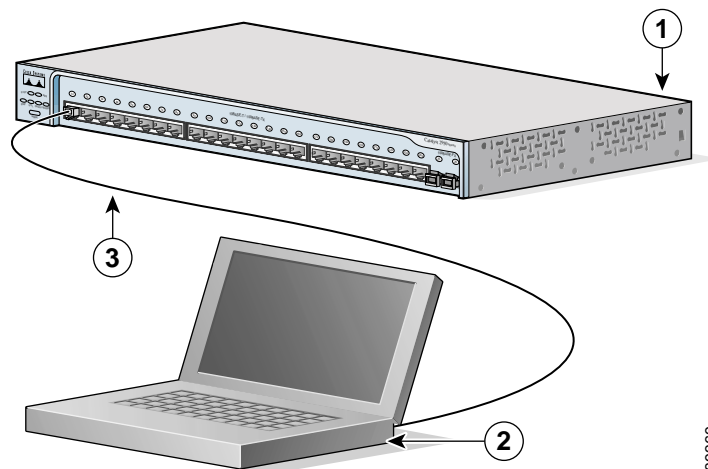
Follow these steps to connect to an 10/100 or 10/100/1000 Ethernet port:

- 
- Step 1** Connect a Category 5 straight-through cable (not supplied) to an 10/100 or 10/100/1000 port on a switch front panel. See [Figure 1-3](#).
- Step 2** Connect the other end of the cable to the Ethernet (RJ-45) port of the workstation, PC, server, or router.
- 

For information about connecting to the GBIC module ports, see the “[Connecting to GBIC Module Ports](#)” section on page 3-44.

For information about connecting to the SFP ports, see the “[Connecting to an SFP Module](#)” section on page 3-49.

**Figure 1-3** Connecting to a Front-Panel Port



89369

1	Catalyst 2950 switch
2	PC
3	Category 5 straight-through cable



# Accessing the Switch from Your Browser

Before using the web-based CMS tools, see these sections for information about appropriate browser and plug-in requirements:

- [Recommended Platform Configuration for Web-Based Management, page 1-12](#)
- [Operating System and Browser Support, page 1-12](#)
- [Guidelines for Installing and Enabling the Java Plug-In, page 1-13](#)
- [Installing the Required Java Plug-In, page 1-14](#)

After you have assigned an IP address to the switch and installed the plug-in, you can access the switch from your browser and use the CMS to configure the switch.



## Note

---

If you have downloaded a new version of CMS, you must clear your browser cache before launching the new CMS version.

When you clear the cache, remove all the jar\_cache\*.tmp files from the temporary directory. The path to the directory is different for these operating systems:

Windows NT and Windows 2000: \TEMP

Windows 95 and 98: \Windows\Temp

---

The browser prompts for a username and password when you access CMS. If no username is configured on your switch (the default), enter only the enable password in the password field.

To display the switch access page, follow these steps:

- 
- Step 1** Enter the switch IP address in the browser **Location** field (Netscape Communicator) or **Address** field (Internet Explorer), and press **Return**.
  - Step 2** Enter your username and password when prompted.  
The Cisco Systems Access page appears. For more information about setting passwords and privilege levels, refer to the switch software configuration guide.
  - Step 3** Click **Web Console** to launch the CMS interface.
-

## Recommended Platform Configuration for Web-Based Management

[Table 1-1](#) lists the recommended platforms for web-based management.

**Table 1-1 Recommended Platform Configuration for Web-Based Management**

OS	Processor Speed	DRAM	Number of Colors	Resolution	Font Size
Windows NT 4.0 <sup>1</sup>	Pentium 300 MHz	128 MB	65,536	1024 x 768	Small
Solaris 2.5.1 or higher	SPARC 333 MHz	128 MB	Most colors for applications	—	Small (3)

1. Service Pack 3 or higher is required.

The minimum PC requirement is a Pentium processor running at 233 MHz with 64 MB of DRAM. The minimum UNIX workstation requirement is a Sun Ultra 1 running at 143 MHz with 64 MB of DRAM.

For information about supported operating systems, see the next section.

## Operating System and Browser Support

You can access the web-based interfaces by using the operating systems and browsers listed in [Table 1-2](#). CMS checks the browser version when starting a session to ensure that the browser is supported. If the browser is not supported, CMS displays an error message, and the session does not start.

**Table 1-2 Supported Operating Systems and Browsers**

Operating System	Minimum Service Pack or Patch	Netscape Communicator <sup>1</sup>	Microsoft Internet Explorer <sup>2</sup>
Windows 95	Service Pack 1	4.75 or 6.2	5.5 or 6.0
Windows 98	Second Edition	4.75 or 6.2	5.5 or 6.0
Windows NT 4.0	Service Pack 3 or later	4.75 or 6.2	5.5 or 6.0
Windows 2000	None	4.75 or 6.2	5.5 or 6.0

**Table 1-2 Supported Operating Systems and Browsers (continued)**

Operating System	Minimum Service Pack or Patch	Netscape Communicator <sup>1</sup>	Microsoft Internet Explorer <sup>2</sup>
Windows XP	None	4.75 or 6.2	5.5 or 6.0
Solaris 2.5.1 or later	Sun-recommended patch cluster for the OS and Motif library patch 103461-24	4.75 or 6.2	Not supported

1. Netscape Communicator version 6.0 is not supported.
2. Service Pack 1 or higher is required for Internet Explorer 5.5.

**Note**

If your browser is Internet Explorer and you receive an error message stating that the page might not display correctly because your security settings prohibit running ActiveX controls, this might mean that your security settings are set too high. To lower security settings, go to **Tools > Internet Options**, and select the **Security** tab. Select the indicated **Zone**, and move the **Security Level for this Zone** slider from **High** to **Medium** (the default) or select the **Custom Level** button and enable the **Run ActiveX controls and plug-ins**.

**Note**

In Cluster Management displays, Internet Explorer versions 4.01 and 5.0 might not display edge devices that are not connected to the command switch. Other functionality is similar to that of Netscape Communicator.

## Guidelines for Installing and Enabling the Java Plug-In

A Java plug-in is required for the browser to access and run the Java-based CMS. Download and install the plug-in before you start CMS.

If CMS does not launch automatically, you might not have a supported Java plug-in installed, or the Java plug-in might not be enabled. CMS does not automatically detect if a supported Java plug-in is installed. If you start CMS without the required Java plug-in installed, the CMS splash screen remains open, and CMS does not launch.

To make sure that a supported Java plug-in is correctly installed and enabled, follow these guidelines:

- If you are using a supported browser and are connected to the Internet, click the Java Plug-In link to download and install a supported Java plug-in.
- If you have installed the Java plug-in but CMS still does not launch, make sure that the plug-in is enabled by selecting **Start > Settings > Control Panel > Java Plug-in**. Click the Basic tab, select Enable Java Plug-in, and click Apply.
- To verify that a supported version of the Java plug-in is installed, select **Start > Settings > Control Panel**. The Java plug-in is listed with the version number in the Control Panel menu.

## Installing the Required Java Plug-In

Each platform, Windows and Solaris, supports three plug-in versions. For information on the supported plug-ins, see the “[Windows XP, Windows 2000, Windows 95, Windows 98, and Windows NT 4.0 Plug-Ins](#)” section on page 1-15 and the “[Solaris Platforms](#)” section on page 1-15.

You can download the recommended plug-ins from this URL:

<http://www.cisco.com/pcgi-bin/tablebuild.pl/java>



### Note

---

Uninstall older versions of the Java plug-ins before installing the Java plug-in.

---

If the Java applet does not initialize after you have installed the plug-in, open the Java Plug-in Control Panel (**Start > Programs > Java Plug-in Control Panel**), and verify these settings:

In the Proxies tab, verify that **Use browser settings** is checked and that no proxies are enabled.

**Note**

If you are running an Internet virus checker on Windows 2000 and the plug-in takes a long time to load, you can speed up CMS operation by disabling the virus checker filter option or download option or both.

From the Start menu on McAfee VirusScan, disable the VirusScan Internet Filter option, the Download Scan option, or both by selecting **Start > Programs > Network Associates > Virus Scan Console > Configure**.

or

From the taskbar, right-click the Virus Shield icon and in the Quick Enable menu, disable the options by deselecting **Internet Filter** or **Download Scan**.

### Windows XP, Windows 2000, Windows 95, Windows 98, and Windows NT 4.0 Plug-Ins

One of these Java plug-ins is required for the browser to access and run the Java-based CMS. These Java plug-ins are supported in Windows environments:

- Java plug-in 1.4
- Java plug-in 1.3.1
- Java plug-in 1.3.0

You can download these plug-ins from this URL:

<http://www.cisco.com/pcgi-bin/tablebuild.pl/java>

### Solaris Platforms

One of these Java plug-ins is required for the browser to access and run the Java-based CMS. These Java plug-ins are supported on the Solaris platform:

- Java plug-in 1.4
- Java plug-in 1.3.1
- Java plug-in 1.3.0

You can download these plug-ins and instructions from this URL:

<http://www.cisco.com/pcgi-bin/tablebuild.pl/java>

To install the Java plug-in, follow the instructions in the README\_FIRST.txt file.





## Overview

---

This chapter provides information about these topics:

- [Features, page 2-1](#)
- [Front-Panel Description, page 2-4](#)
- [Rear-Panel Description, page 2-27](#)
- [Management Options, page 2-32](#)

## Features

The Catalyst 2950 switches are a family of Ethernet switches that you can use to connect workstations and other network devices, such as servers, routers, and other switches. All models of the switch are cluster-capable, but only some models are stackable. You can use switches with Gigabit Interface Converter (GBIC) module slots to create switch stacks by using Gigastack GBICs. Some switch models can be deployed as backbone switches, aggregating 10BASE-T, 100BASE-TX, Gigabit Ethernet, and Long-Reach Ethernet (LRE) traffic from other switches and network devices. Refer to the switch software configuration guide for examples that show how you might deploy the switches in your network.

Figure 2-1 through Figure 2-12 show the Catalyst 2950 switches.

These are the switch features:

- Hardware
  - Catalyst 2950-12 switch—12 10/100 Ethernet ports.
  - Catalyst 2950-24 switch—24 10/100 Ethernet ports.
  - Catalyst 2950C-24 switch—24 10/100 Ethernet ports and 2 100BASE-FX ports.
  - Catalyst 2950G-12-EI—12 10/100 Ethernet ports and 2 GBIC module slots.
  - Catalyst 2950G-24-EI—24 10/100 Ethernet ports and 2 GBIC module slots.
  - Catalyst 2950G-24-EI-DC—24 10/100 Ethernet ports and 2 GBIC module slots with direct current (DC)-input power.
  - Catalyst 2950G-48-EI—48 10/100 Ethernet ports and 2 GBIC module slots.
  - Catalyst 2950ST-8 LRE switch—8 LRE ports, 2 10/100/1000 Ethernet ports, and 2 small-form-factor pluggable (SFP) module slots. (Two of the four uplink ports are active at one time.)
  - Catalyst 2950ST-24 LRE switch—24 LRE ports, 2 10/100/1000 Ethernet ports, and 2 SFP module slots. (Two of the four uplink ports are active at one time.)
  - Catalyst 2950ST-24 LRE 997 switch—24 LRE ports, 2 10/100/1000 Ethernet ports, and 2 SFP module slots with DC-input power. (Two of the four uplink ports are active at one time.)

**Note**

---

Refer to the Catalyst 2950 LRE switch release notes for a list of supported SFP modules for the Catalyst 2950 LRE switches.

---

- Catalyst 2950SX-24 switch—24 10/100 Ethernet ports and 2 1000BASE-SX ports.
- Catalyst 2950T-24 switch—24 10/100 Ethernet ports and 2 10/100/1000 Ethernet ports.



- On Catalyst 2950G-12-EI, 2950G-24-EI, 2950G-24-EI-DC, and 2950G-48-EI switches, support for these GBIC modules:
  - 1000BASE-SX GBIC
  - 1000BASE-LX/LH GBIC
  - 1000BASE-ZX GBIC
  - 1000BASE-T GBIC (model WS-5483)
  - Coarse Wave Division Multiplexer (CWDM) fiber-optic GBIC
  - GigaStack GBIC
- Configuration
  - For 10/100 ports, autonegotiates the speed and duplex settings.
  - For 10/100/1000 ports on the Catalyst 2950T-24 switch, autonegotiates the speed and supports only full-duplex mode.
  - For 10/100/1000 ports on the Catalyst 2950 LRE switches, autonegotiates the speed and duplex setting when operating at 10 or 100 Mbps. When the switch is running at 1000 Mbps, it supports only full-duplex mode.
  - For 100BASE-FX ports, supports only 100-Mbps and full-duplex settings.
  - For 1000BASE-SX ports, supports only 1000-Mbps and full-duplex settings.
  - Supports 8192 MAC addresses.
  - Checks for errors on a received packet, determines the destination port, stores the packet in shared memory, and then forwards the packet to the destination port.
- Power redundancy
  - Connection for an optional Cisco RPS 300 redundant power system (RPS) that uses AC input and supplies DC output to the switch
  - Connection for an optional Cisco RPS 675 that uses AC input and supplies DC output to the switch

Certain Cisco LRE customer premises equipment (CPE) devices are not supported by certain Catalyst 2950 LRE switches. In [Table 2-1](#), *Yes* means that the CPE is supported by the switch; *No* means that the CPE is not supported by the switch.

**Table 2-1** LRE Switch and CPE Compatibility Matrix

LRE Devices	Catalyst 2950ST-8 LRE switch	Catalyst 2950ST-24 LRE switch	Catalyst 2950ST-24 LRE 997 switch
Cisco 575 LRE CPE	Yes	Yes	No
Cisco 576 LRE 997 CPE	No	No	Yes
Cisco 585 LRE CPE	Yes	Yes	No

## Front-Panel Description

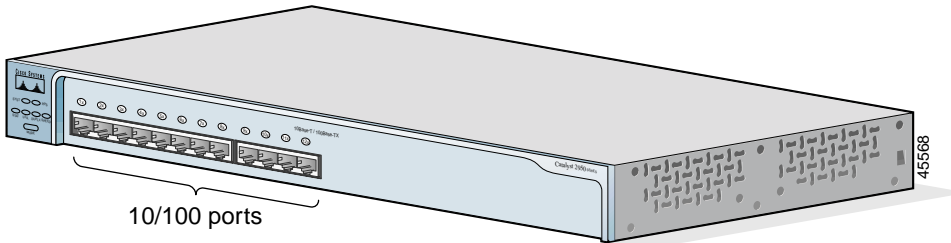
The switch front panel contains the ports, the LEDs, and the Mode button.

Other than the Catalyst 2950ST-24 LRE 997 switch, the front panel of the Catalyst 2950 LRE switches also contains the console port and AC power connector. On the Catalyst 2950ST-24 LRE 997 switch, the front panel contains a DC power connector (also referred to as the terminal block header), a DC ground lug, and an RJ-45 console port.

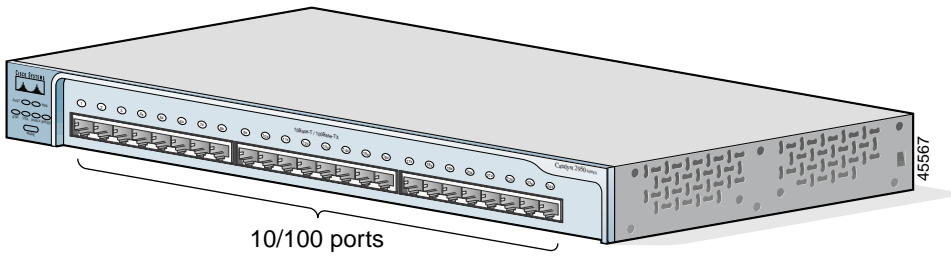
For more information about the power connectors on the LRE switches, see the [“Power Connectors” section on page 2-29](#). For more information on the console port on these switches, see the [“Console Port” section on page 2-31](#).

Figure 2-1 to Figure 2-12 show the switches.

**Figure 2-1 Catalyst 2950-12 Switch**



**Figure 2-2 Catalyst 2950-24 Switch**



**Figure 2-3 Catalyst 2950C-24 Switch**

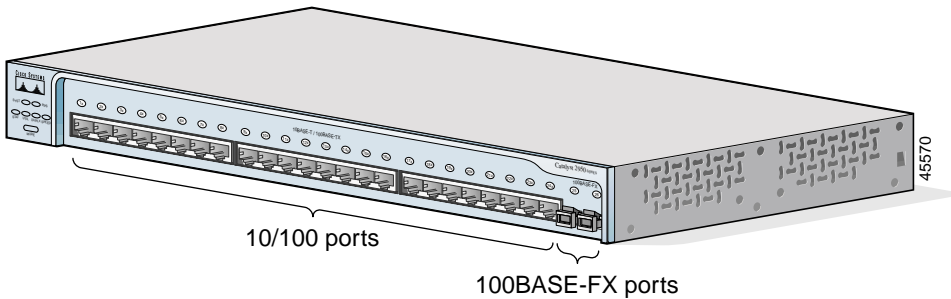


Figure 2-4 Catalyst 2950G-12-EI Switch

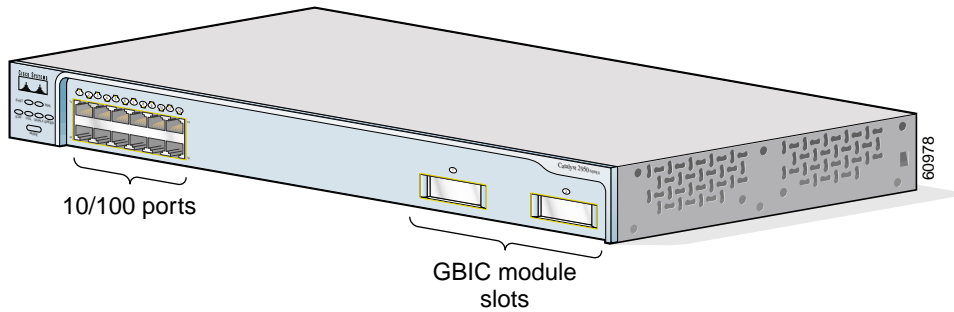


Figure 2-5 Catalyst 2950G-24-EI Switch

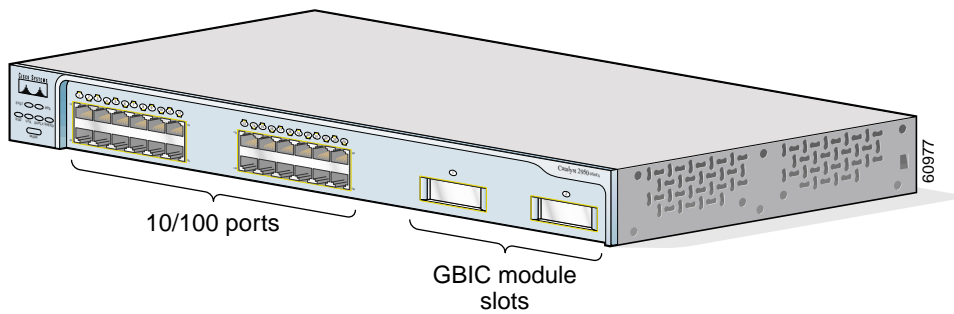


Figure 2-6 Catalyst 2950G-24-EI-DC Switch

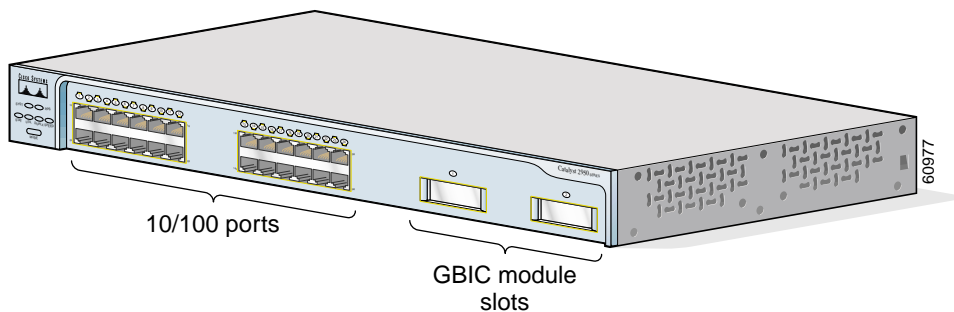


Figure 2-7 Catalyst 2950G-48-EI Switch

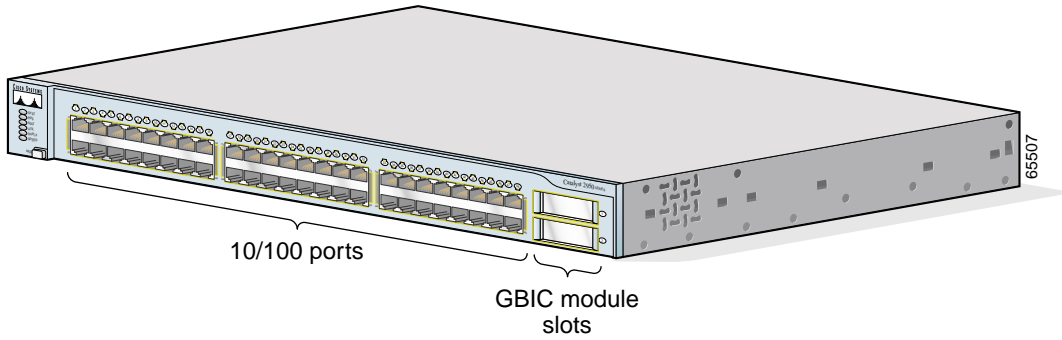


Figure 2-8 Catalyst 2950ST-8 LRE Switch

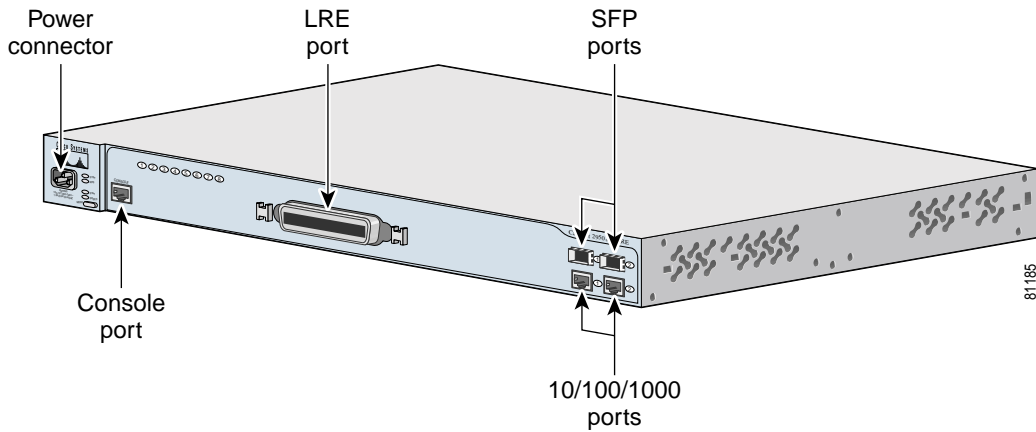


Figure 2-9 Catalyst 2950ST-24 LRE Switch

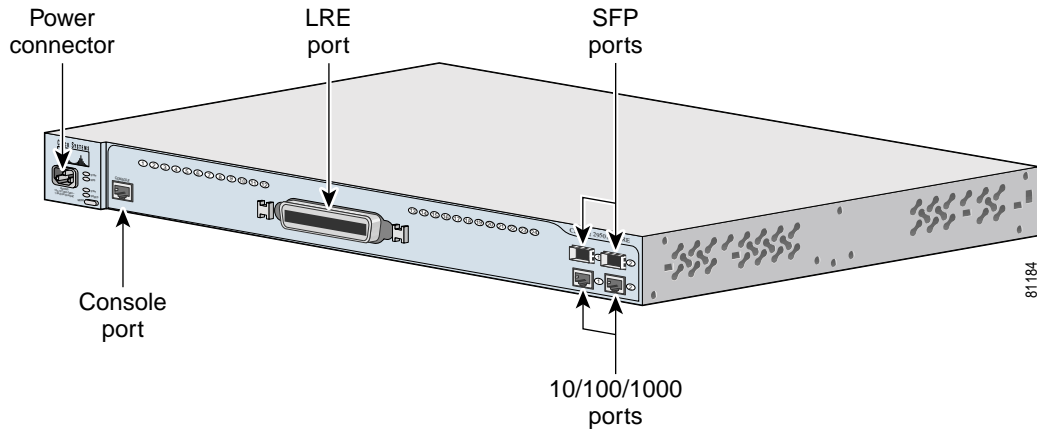


Figure 2-10 Catalyst 2950ST-24 LRE 997 Switch

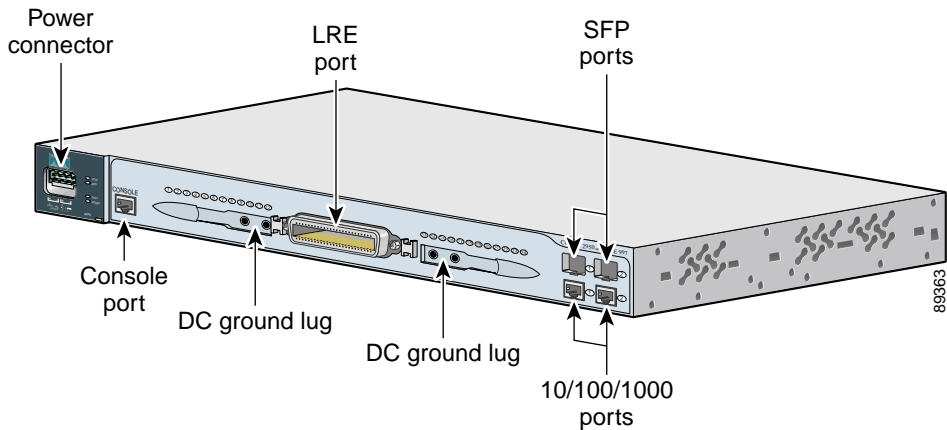


Figure 2-11 Catalyst 2950SX-24 Switch

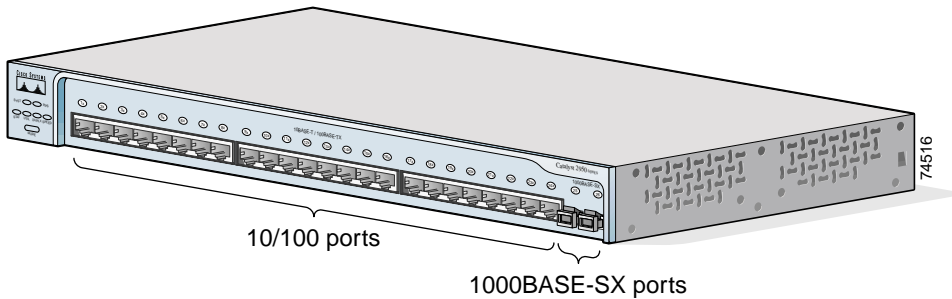
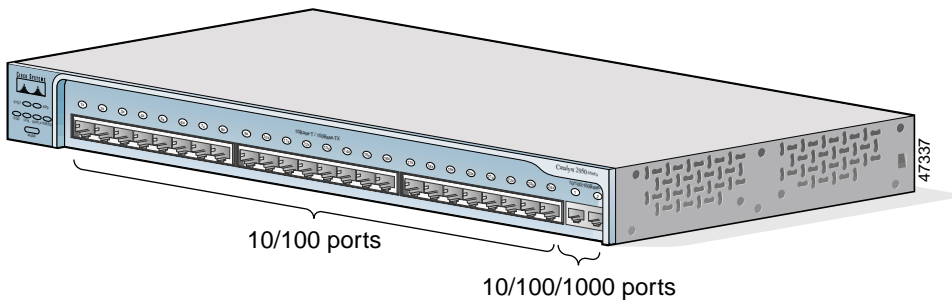


Figure 2-12 Catalyst 2950T-24 Switch



## 10/100 Ports

The 10/100 ports use RJ-45 connectors and twisted-pair cabling. The ports can connect to these devices:

- 10BASE-T devices, such as workstations and hubs, through standard RJ-45 connectors and two twisted-pair cabling. You can use Category 3, 4, or 5 cabling.
- 100BASE-TX devices, such as high-speed workstations, servers, hubs, routers, and other switches, through standard RJ-45 connectors and two or four twisted-pair, Category 5 cabling.

**Note**

---

When connecting the switch to workstations, servers, and routers, be sure that the cable is a twisted-pair straight-through cable. When connecting the switch to hubs or other switches, use a twisted-pair crossover cable. Pinouts for the cables are described in [Appendix B, “Connectors and Cables.”](#)

---

The 10/100 ports can be explicitly set to operate in any combination of half duplex, full duplex, 10 Mbps, or 100 Mbps. They can also be set for speed and duplex autonegotiation, compliant with IEEE 802.3U. In all cases, the cable length from a switch to an attached device cannot exceed 328 feet (100 meters).

When set for autonegotiation, a port senses the speed and duplex settings of the attached device and advertises its own capabilities. If the attached device supports autonegotiation, the port negotiates the best connection (that is, the fastest line speed that both devices support and full-duplex transmission, if the attached device supports it) and configures itself accordingly.

## 10/100/1000 Ports

The 10/100/1000 ports on the Catalyst 2950T-24 and the Catalyst 2950 LRE switches use RJ-45 connectors and twisted-pair cabling. The ports can connect to these devices:

- 10BASE-T devices, such as workstations and hubs, through standard RJ-45 connectors and two or four twisted-pair, Category 5 cabling.
- 100BASE-TX devices, such as high-speed workstations, servers, hubs, routers, and other switches, through standard RJ-45 connectors and two or four twisted-pair, Category 5 cabling.
- 1000BASE-T devices, such as high-speed workstations, servers, hubs, routers, and other switches, through standard RJ-45 connectors and four twisted-pair, Category 5 cabling.

**Note**

---

When connecting the switch to a 1000BASE-T device, be sure to use a four twisted-pair, Category 5 cable.

---



**Note**

---

When connecting the switch to workstations, servers, and routers, be sure to use a twisted-pair straight-through cable. When connecting the switch to hubs or other switches, use a twisted-pair crossover cable. Pinouts for the cables are described in [Appendix B, “Connectors and Cables.”](#)

---

The 10/100/1000 ports on the Catalyst 2950T-24 switch can be explicitly set to operate at 10, 100, or 1000 Mbps but only in full-duplex mode. The 10/100/1000 ports on the Catalyst 2950 LRE switches can be explicitly set to operate at 10 or 100 Mbps in full- or half-duplex mode or at 1000 Mbps in full-duplex mode.

The 10/100/1000 ports can also be set for speed autonegotiation, compliant with IEEE 802.3AB. In all cases, the cable length from a switch to an attached device cannot exceed 328 feet (100 meters).

**Note**

---

On the Catalyst 2950 LRE switches, the four input uplink ports are bundled as two logical ports, each consisting of a copper 10/100/1000 port and a fiber-optic SFP module slot, respectively.

Within each logical port, you can use only the copper or the fiber-optic port at one time. If a Catalyst 2950 LRE switch senses more than two connections for both logical ports, the switch chooses the fiber-optic connections over the copper connections in default operation.

See the [“SFP Module Slots” section on page 2-14](#) for more information on LRE uplink logical ports.

---

## 100BASE-FX and 1000BASE-SX Ports

The 100BASE-FX and 1000BASE-SX ports both use 50/125- or 62.5/125-micron multimode fiber-optic cabling. The 100BASE-FX ports operate only at 100 Mbps in full-duplex mode, and the 1000BASE-SX ports operate only at 1000 Mbps in full-duplex mode.

In full-duplex mode, the cable length from a 100BASE-FX port on a switch to an attached device cannot exceed 6562 feet (2 kilometers). The cable length from a 1000BASE-SX port on a switch to an attached device cannot exceed 1804 feet (550 meters).

You can connect a 100BASE-FX or 1000BASE-SX port to an SC or ST port on a target device by using one of the MT-RJ fiber-optic patch cables listed in [Table 3-1 on page 3-36](#). Use the Cisco part numbers in [Table 3-1](#) to order the patch cables that you need.

## LRE Port

The LRE port (shown in [Figure 2-8](#)) uses one RJ-21 connector to connect up to 24 Cisco LRE CPE devices through structured or unstructured wiring, such as existing telephone lines. The link between the LRE switch port and each CPE device can reach speeds of up to 15 Mbps (full duplex) over distances of up to 4921 feet (1500 meters).

Certain Catalyst 2950 LRE switches support certain Cisco LRE CPE devices. [Table 2-1 on page 2-4](#) shows which LRE switches support which CPE devices.

You can connect the Cisco 575 LRE CPE and Cisco 585 LRE CPE devices to LRE ports on the same Catalyst 2950ST-8 LRE or 2950ST-24 LRE switch. You can connect the Cisco 576 LRE CPE 997 device only to LRE ports on a Catalyst 2950ST-24 LRE 997 switch. You can hot swap the CPE devices without powering down the switch or disrupting the other switch ports.

The default mode for each LRE port is speed autosensing and half-duplex operation. For information about configuring the LRE ports, refer to the switch software configuration guide.

If telephone services, such as voice or an Integrated Services Digital Network (ISDN), use the same cabling as LRE traffic, the LRE port must be connected to the patch panel through a *plain old telephone service* (POTS) splitter. The splitter routes LRE data (high-frequency) and voice (low-frequency) traffic from the telephone line to the switch and private branch exchange (PBX) switch or public switched telephone network (PSTN).

If the other telephone services are connected through a PBX switch, a non-homologated POTS splitter, such as the Cisco LRE 48 POTS Splitter, can be used. The PBX routes voice traffic to private telephone networks and the PSTN. For more information about the Cisco LRE 48 POTS Splitter (PS-1M-LRE-48), refer to the *Installation and Warranty Notes for the Cisco LRE 48 POTS Splitter*.

For limitations and restrictions when you use a POTS splitter with the Catalyst 2950 LRE switches and Cisco LRE CPE, see the [“Limitations and Restrictions with POTS Splitters” section on page 3-39](#).

If the installation does not have a PBX, a homologated POTS splitter is required to connect directly to the PSTN. For more information about homologated POTS splitters, contact your Cisco sales representative.

If a connection to a telephone network is not required, a splitter is not needed, and the switch can connect directly to the patch panel.

For more information about the Cisco LRE CPE devices, refer to the *Cisco LRE CPE Hardware Installation Guide*.

## GBIC Module Ports

The GBIC module slots support these modules:

- 1000BASE-SX GBIC module for fiber-optic connections that cannot exceed 1804 feet (550 meters).
- 1000BASE-LX/LH GBIC module for fiber-optic connections that cannot exceed 32,810 feet (10 kilometers).
- 1000BASE-ZX GBIC module for fiber-optic connections that cannot exceed 328,100 feet (100 kilometers).
- 1000BASE-T GBIC module for copper connections that cannot exceed 328 feet (100 meters).
- CWDM GBIC module for single-mode fiber-optic connections that cannot exceed 393,719 feet (120 kilometers).
- GigaStack GBIC module for creating a 1-Gbps stack configuration of up to nine supported switches. The GigaStack GBIC supports one full-duplex link (in a point-to-point configuration) or up to nine half-duplex links (in a stack configuration) to other Gigabit Ethernet devices. Using the required Cisco proprietary signaling and cabling, the GigaStack GBIC-to-GigaStack GBIC connection cannot exceed 3 feet (1 meter).

**Note**

---

Cisco-approved CWDM GBIC modules have a serial EEPROM that contains the module serial number, the vendor name and ID, a unique security code, and cyclic redundancy check (CRC). When a GBIC module is inserted in the switch, the switch software reads the EEPROM to check the serial number, vendor name, and vendor ID and recomputes the security code and CRC. If the serial number, the vendor name or ID, security code, or CRC is invalid, the switch places the interface in an error-disabled state.

---

**Note**

---

If you are using a non-Cisco approved CWDM GBIC module, remove the module from the switch, and replace it with a Cisco-approved module.

---

For more information about these GBIC modules, refer to your GBIC module documentation.

## SFP Module Slots

On the Catalyst 2950 LRE switch, the SFP module slots support the SFP modules listed in the Catalyst 2950 LRE switch release notes.

The Catalyst 2950 LRE switch has four physical input ports that are logically bundled as two ports. Each logical port consists of a copper 10/100/1000 port and a fiber-optic SFP module slot. These ports appear as a vertical column on the front panel and are labeled Uplink Port 1 and Uplink Port 2.

Within each port, you can use only one of the two physical ports, either the SFP module port or the 10/100/1000 port. For example, you can connect to either the SFP module port or the 10/100/1000 port on Uplink Port 1. If you connect to both, in default operation, the SFP module port has priority over the 10/100/1000 port. Using this example, a valid configuration would be connecting to the fiber-optic port on Uplink Port 1 and the copper port on Uplink Port 2.

**Note**

---

By using the **media-type {sfp | rj45 | auto-select}** command at the Cisco IOS command-line interface (CLI), you can configure the Catalyst 2950 LRE switch so that the SFP module port does not take precedence over the 10/100/1000 port. In that scenario, whichever media type establishes a link first has precedence over the other.

For more information about the **media-type {sfp | rj45 | auto-select}** command, refer to the switch command reference.

---

## SFP Modules

The LRE switch uses Gigabit Ethernet SFP modules to establish fiber-optic connections. These laser optical-transceiver modules are field-replaceable, and you can insert them into an SFP module slot. Use fiber-optic cables with LCs to connect to an SFP module. You can use the SFP modules for Gigabit uplink connections to other switches.

The SFP modules support nominal wavelengths from 850 to 1550 nanometers (nm). The Catalyst 2950 LRE switches support these Cisco SFP options:

- 1000BASE-LX
- 1000BASE-SX
- 1000BASE-ZX

Refer to the Catalyst 2950 LRE switch release notes for the list of supported SFPs.

The two SFP modules are inserted into SFP module slots on the front of the Catalyst 2950 LRE switches. These field-replaceable modules provide the uplink optical interfaces, laser send (TX), and laser receive (RX).

You can use any combination of SFP modules that the switch supports. Each port must match the wave-length specifications on the other end of the cable, and the cable must not exceed the stipulated cable length for reliable communications.

[Table 2-2](#) lists these stipulations.

**Table 2-2 Cabling Stipulations for SFP Modules**

SFP Module	62.5/125 micron Multimode 850 nm <sup>1</sup> Fiber	50/125 micron Multimode 850 nm Fiber	62.5/125 micron Multimode 1310 nm Fiber	50/125 micron Multimode 1310 nm Fiber	9/125 micron Single-mode 1310 nm fiber	9/10 micron Single-mode 1550 nm fiber
SX	275 m <sup>2</sup> at 200 Mhz <sup>3</sup> -km <sup>4</sup>	550 m at 500 Mhz-km	—	—	—	—
LX	—	—	550 m at 500 Mhz-km	550 m at 400 Mhz-km	10 km	—
ZX	—	—	—	—	—	70 to 100 km (43.4 to 62 miles) <sup>5</sup>

1. nm = nanometer
2. m = meter
3. Mhz = megahertz
4. km = kilometer
5. You need to use dispersion-shifted or low-attenuation single-mode fiber (SMF) for connections of up to 100 kilometers (328,100 feet). The actual distance depends on the fiber quality, the number of splices, and the type of connectors used.

Use only Cisco-approved SFP modules on the Catalyst 2950 LRE switch.

**Note**

Cisco-approved SFP modules have a serial EEPROM that contains the module serial number, the vendor name and ID, a unique security code, and cyclic redundancy check (CRC). When an SFP module is inserted in the switch, the switch software reads the EEPROM to check the serial number, vendor name, and vendor ID and recomputes the security code and CRC. If the serial number, the vendor name or ID, security code, or CRC is invalid, the switch places the interface in an error-disabled state.

**Note**

If you are using a non-Cisco approved SFP module, remove the module from the switch, and replace it with a Cisco-approved module.

For more information about these SFP modules, refer to your SFP module documentation.

## LEDs

You can use the LEDs to monitor switch activity and performance. The locations of the LEDs vary among switch models. The Mode button that you use to select the port mode also varies by model. See these figures:

- [Figure 2-13](#) for the Catalyst 2950-12, 2950-24, 2950C-24, 2950SX-24, and 2950T-24 switches
- [Figure 2-14](#) for the Catalyst 2950G-12-EI, 2950G-24-EI, and 2950G-24-EI-DC switches
- [Figure 2-15](#) for the Catalyst 2950G-48-EI switches
- [Figure 2-16](#) for the Catalyst 2950ST-8 LRE and 2950ST-24 LRE switches
- [Figure 2-16](#) for the Catalyst 2950ST-24 LRE 997 switches

All of the LEDs described in this section (except the utilization meter [UTIL]) are visible in the Cluster Management Suite (CMS). The switch software configuration guide describes how to use CMS to configure and to monitor individual switches and switch clusters.

**Figure 2-13 LEDs on Catalyst 2950-12, 2950-24, 2950C-24, 2950SX-24, and 2950T-24 Switches**

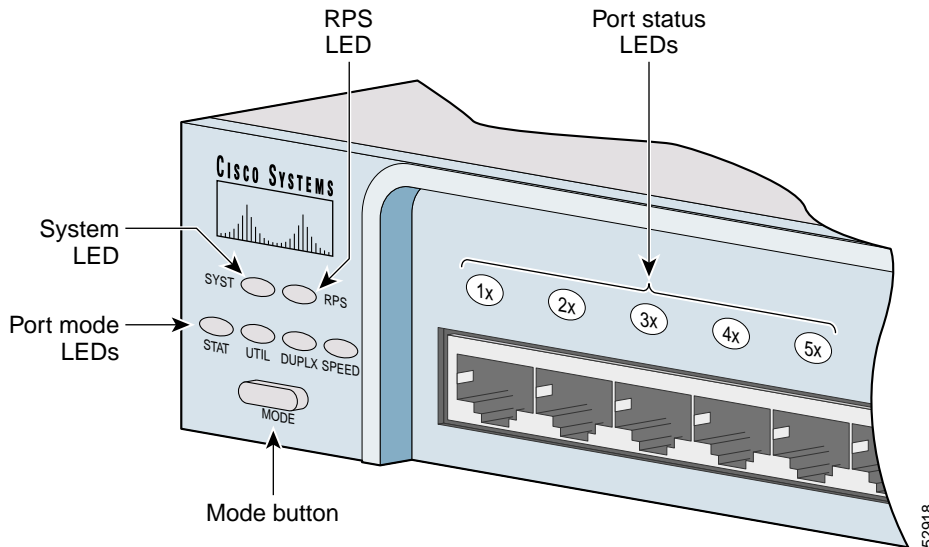


Figure 2-14 LEDs on Catalyst 2950G-12-EI, 2950G-24-EI, and 2950G-24-EI-DC Switches

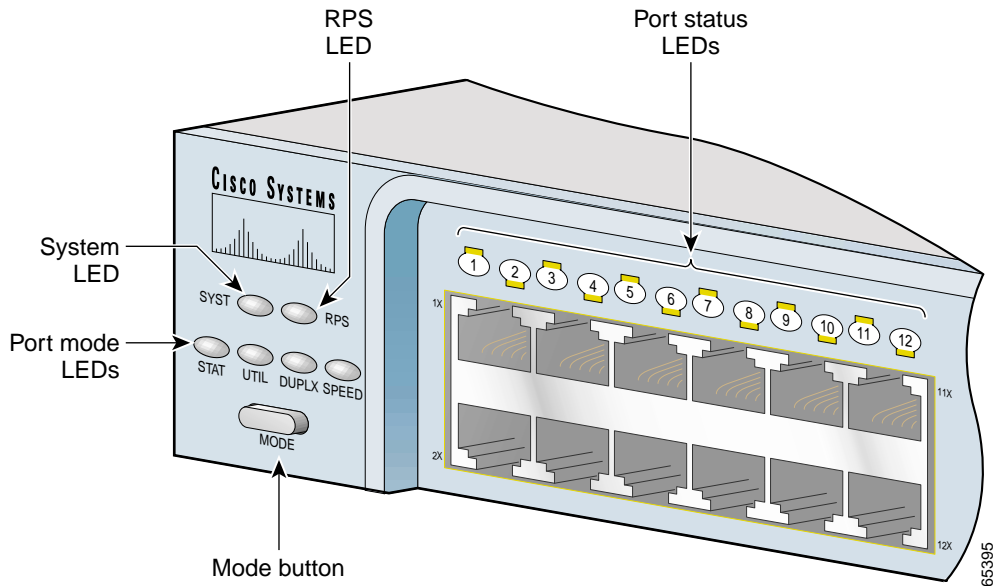


Figure 2-15 LEDs on Catalyst 2950G-48-EI Switches

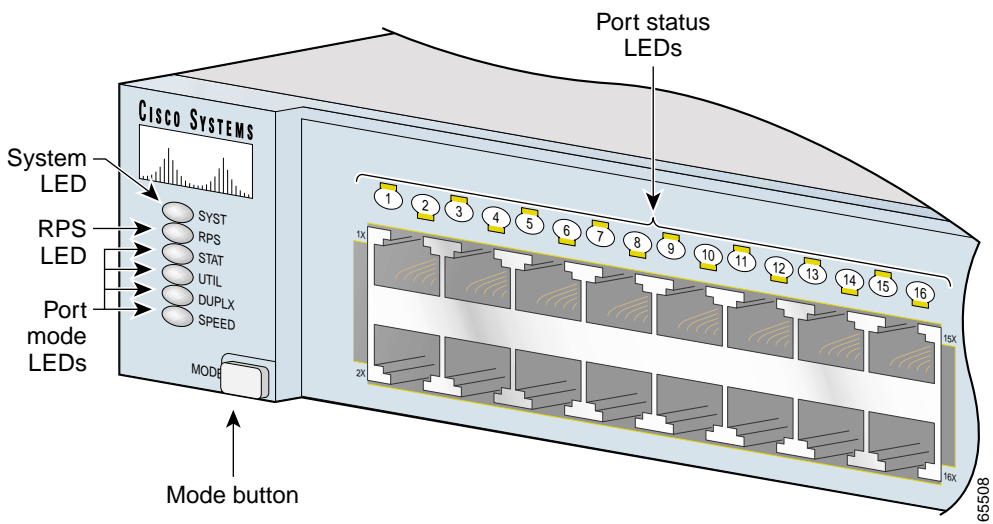




Figure 2-16 LEDs on Catalyst 2950ST-8 LRE and 2950ST-24 LRE Switches

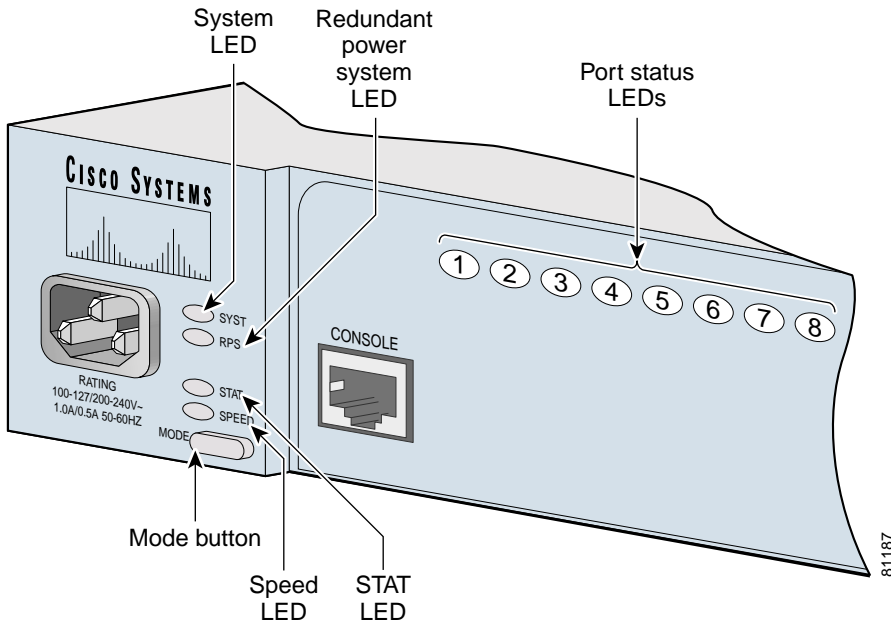
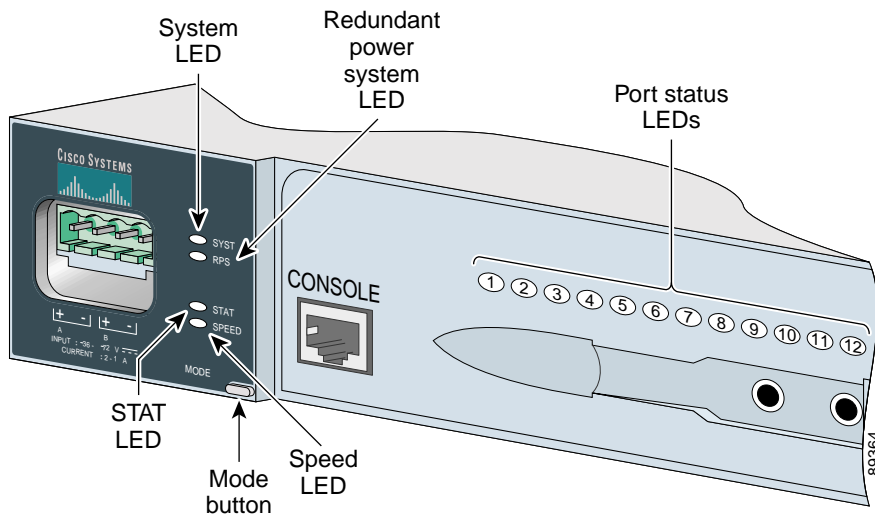


Figure 2-17 LEDs on Catalyst 2950ST-24 LRE 997 Switches



## System LED

The system LED shows whether the system is receiving power and functioning properly. [Table 2-3](#) lists the LED colors and meanings.

**Table 2-3** System LED

Color	System Status
Off	System is not powered up.
Green	System is operating normally.
Amber	System is receiving power but is not functioning properly.

For information about the system LED colors during the power-on self-test (POST), see the [“Connecting to a Power Source”](#) section on page 1-5.

## RPS LED

The RPS LED shows the RPS status. [Table 2-4](#) lists the LED colors and meanings.

**Table 2-4 RPS LED**

Color	RPS Status
Off	RPS is off or is not installed.
Solid green	RPS is connected and ready to provide back-up power.
Flashing green	RPS is connected but is unavailable because it is providing power to another device (redundancy has been allocated to a neighboring device).
Solid amber	RPS is in standby mode or in a fault condition. Press the Standby/Active button on the RPS, and the LED should turn green. If it does not, the RPS fan could have failed. Contact Cisco Systems.
Flashing amber	The internal power supply in a switch has failed, and the RPS is providing power to the switch (redundancy has been allocated to this device).

For more information about the Cisco RPS 300, refer to the *Cisco RPS 300 Redundant Power System Hardware Installation Guide*.

For more information about the Cisco RPS 675, refer to the *Cisco RPS 675 Redundant Power System Hardware Installation Guide*.

## Port Mode and Port Status LEDs

To select or change the port mode, press the Mode button (see [Figure 2-13](#) to [Figure 2-16](#)) to highlight the mode that you want. Release the button to enable the highlighted mode.

Each port has a port status LED, also called a port LED. These LEDs, as a group or individually, display information about the switch and the individual ports. The port modes (see [Table 2-5](#)) determine the type of information displayed.

**Table 2-5 Port Mode LEDs**

Mode LED	Port Mode	Description
STAT	Port status	The port status. This is the default mode.
UTIL <sup>1</sup>	Switch utilization	The bandwidth in use by the switch.
DUPLX <sup>2</sup>	Port duplex mode	The port duplex mode: half duplex or full duplex.
SPEED	Port speed	The port operating speed: 10 or 100 Mbps for 10/100 ports and 10, 100, or 1000 Mbps for 10/100/1000 ports.

1. A Catalyst 2950 LRE switch does not have a UTIL LED.
2. A Catalyst 2950 LRE switch does not have a DUPLX LED.

When you change the port mode, the meanings of the port LED colors change. [Table 2-6](#) explains how to interpret these colors for the non-LRE switches. [Table 2-7](#) explains how to interpret the colors for the LRE switches. The port LEDs are off when the MODE is set to SPEED.

**Table 2-6 Meaning of Port LED Colors in Different Modes for Non-LRE Switches**

Port Mode	Color	Meaning
STAT (port status)	Off	No link.
	Solid green	Link present.
	Flashing green	Activity. Port is sending or receiving data.
	Alternating green-amber	Link fault. Error frames can affect connectivity, and errors such as excessive collisions, CRC errors, and alignment and jabber errors are monitored for a link-fault indication.
	Solid amber	Port is not forwarding. Port was disabled by management, an address violation, or Spanning Tree Protocol (STP).  <b>Note</b> After a port is reconfigured, the port LED can remain amber for up to 30 seconds while STP checks the switch for possible loops.

Table 2-6 Meaning of Port LED Colors in Different Modes for Non-LRE Switches (continued)

Port Mode	Color	Meaning
UTIL (utilization)	Green	The current backplane utilization that is displayed over the amber LED background on a logarithmic scale.
	Amber	The maximum backplane utilization since the switch was powered on.
	Green and amber	See <a href="#">Figure 2-18</a> to <a href="#">Figure 2-22</a> for details. <b>Note</b> If the current utilization exceeds the maximum utilization, the maximum utilization is automatically updated.
DUPLX (half or full duplex)	Off	Port is operating in half duplex.
	Green	Port is operating in full duplex.
SPEED	10/100 ports	
	Off	Port is operating at 10 Mbps.
	Green	Port is operating at 100 Mbps.
	10/100/1000 ports	
	Off	Port is operating at 10 Mbps.
	Green	Port is operating at 100 Mbps.
	Flashing green	Port is operating at 1000 Mbps.
	1000BASE-X GBIC module ports	
	Off	Port is not operating.
Green	Port is operating at 1000 Mbps.	

Table 2-7 Meaning of Port LED Colors in Different Modes for the LRE Switches

Port Mode	Color	Meaning
STAT (port status)	Off	No link.
	Solid green	Link present. <b>Note</b> The LRE port LED turns green approximately 30 seconds after the LRE port detects a connection to an LRE CPE.
	Flashing green	Activity. Port is sending or receiving data.
	Alternating green-amber	Link fault. Error frames can affect connectivity, and errors such as excessive collisions, CRC errors, and alignment and jabber errors are monitored for a link-fault indication.
	Solid amber	A link is established on a nonassigned LRE profile, or a port is not forwarding. If a port is not forwarding, it was disabled by management, an address violation, or STP. <b>Note</b> After a port is reconfigured, the port LED can remain amber for up to 30 seconds while STP checks the switch for possible loops.
DUPLX (half or full duplex)	Off	Port is operating in half duplex.
	Green	Port is operating in full duplex.
SPEED	10/100/1000 ports <sup>1 2</sup>	
	Off	Port is operating at 10 Mbps.
	Green	Port is operating at 100 Mbps.
	Flashing green	Port is operating at 1000 Mbps.
	SFP modules <sup>1 2</sup>	
	Off	Port is operating at 10 Mbps
	Green	Port is operating at 100 Mbps
Flashing green	Port is operating at 1000 Mbps	

- On an LRE switch, the LEDs for Uplink Port 1 and Uplink Port 2 correspond either to the SFP module port or to the 10/100/1000 port, depending on which is active.
- If an LRE switch senses connections to both ports, by default, the switch chooses the fiber-optic connection over the copper connection.

For more information about GBIC LEDs, refer to your GBIC module documentation.

Figure 2-18 to Figure 2-22 show the bandwidth utilization percentages displayed by the right-most LEDs.

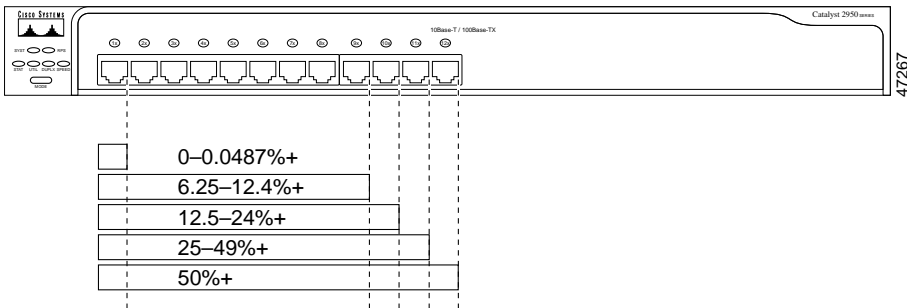


**Note**

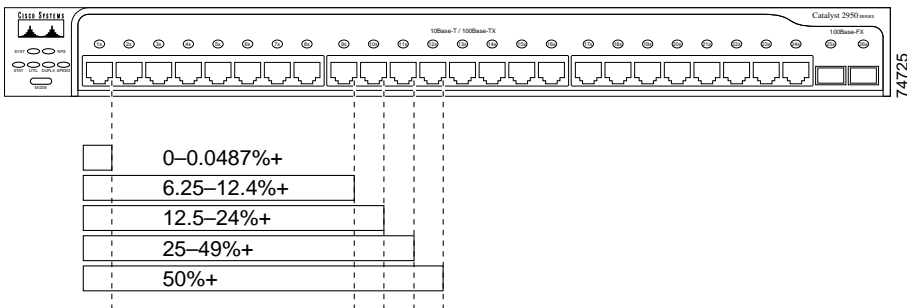
The Catalyst 2950 LRE switch LEDs do not give utilization status.

If all LEDs on a Catalyst 2950-12, 2950-24, 2950C-24, 2950SX-24, or 2950T-24 switch are green (no amber showing), the switch is using 50 percent or more of the total bandwidth. If the far-right LED is off, the switch is using more than 25 but less than 50 percent of the total bandwidth, and so on. If only the far-left LED is green, the switch is using less than 0.0488 percent of the total bandwidth. (See Figure 2-18 and Figure 2-19.)

**Figure 2-18 Bandwidth Utilization on Catalyst 2950-12 Switches**

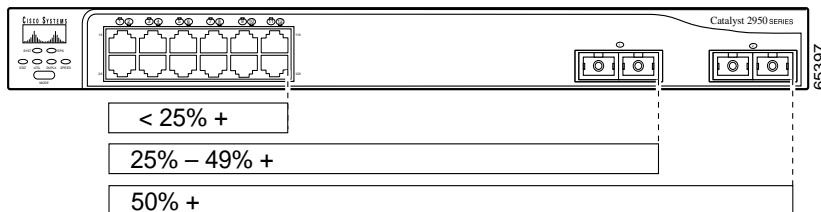


**Figure 2-19 Bandwidth Utilization on Catalyst 2950-24, 2950C-24, 2950SX-24, and 2950T-24 Switches**



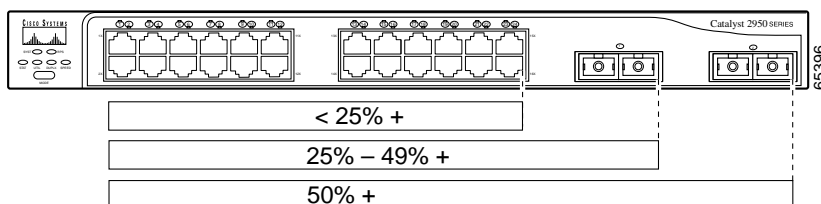
If all LEDs on a Catalyst 2950G-12-EI switch are green (no amber showing), the switch is using 50 percent or more of the total bandwidth. If the LED for GBIC module slot 2 is off, the switch is using more than 25 but less than 50 percent of the total bandwidth. If LEDs for both GBIC module slots are off, the switch is using less than 25 percent of the total bandwidth, and so on. (See [Figure 2-20](#).)

**Figure 2-20** Bandwidth Utilization on Catalyst 2950G-12-EI Switches



If all LEDs on a Catalyst 2950G-24-EI or 2950G-24-EI-DC switch are green (no amber showing), the switch is using 50 percent or more of the total bandwidth. If the LED for GBIC module slot 2 is off, the switch is using more than 25 but less than 50 percent of the total bandwidth. If LEDs for both GBIC module slots are off, the switch is using less than 25 percent of the total bandwidth, and so on. (See [Figure 2-21](#).)

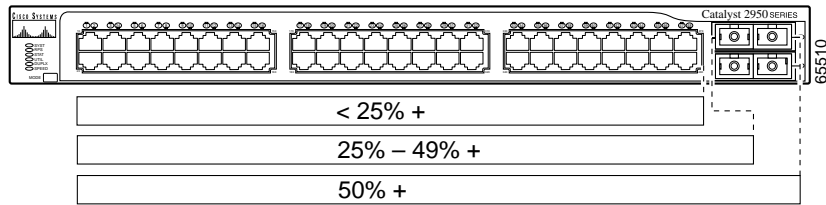
**Figure 2-21** Bandwidth Utilization on Catalyst 2950G-24-EI and 2950G-24-EI-DC Switches



If all LEDs on a Catalyst 2950G-48-EI switch are green (no amber showing), the switch is using 50 percent or more of the total bandwidth. If the LED for GBIC module slot 2 is off, the switch is using more than 25 but less than 50 percent of the total bandwidth. If LEDs for both GBIC module slots are off, the switch is using less than 25 percent of the total bandwidth, and so on. (See [Figure 2-22](#).)



Figure 2-22 Bandwidth Utilization on Catalyst 2950G-48-EI Switches



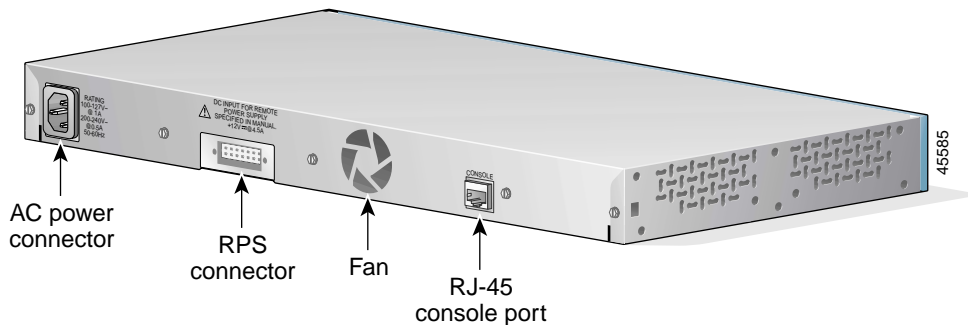
## Rear-Panel Description

Other than the Catalyst 2950G-24-EI-DC switch and the Catalyst 2950 LRE switches, the rear panel of a Catalyst 2950 switch has an AC power connector, an RPS connector, and an RJ-45 console port. (See [Figure 2-23](#) and [Figure 2-24](#).)

The rear panel of the Catalyst 2950G-24-EI-DC switch has a DC power connector (also referred to as the terminal block header), a DC ground lug, an RPS connector, and an RJ-45 console port. (See [Figure 2-25](#).)

The rear panel of the Catalyst 2950ST-8 LRE, 2950ST-24 LRE, and 2950ST-24 LRE 997 switches has only an RPS connector. (See [Figure 2-26](#).)

Figure 2-23 Catalyst 2950 Switch Rear Panel



## Rear-Panel Description

Figure 2-24 Catalyst 2950G-48-EI Switch Rear Panel

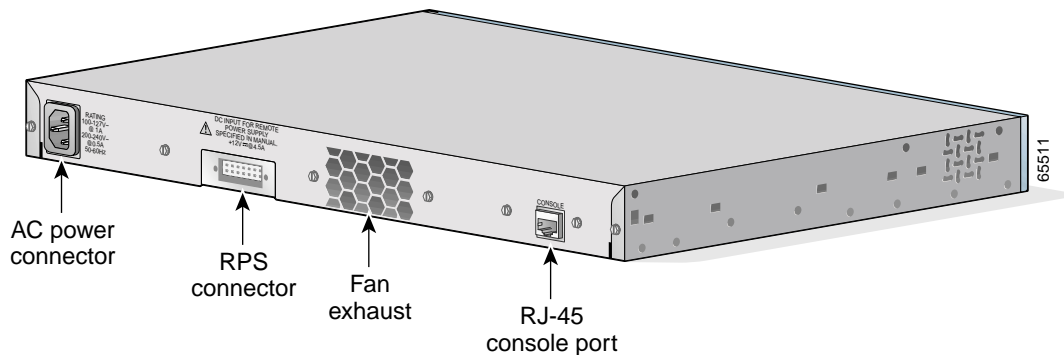
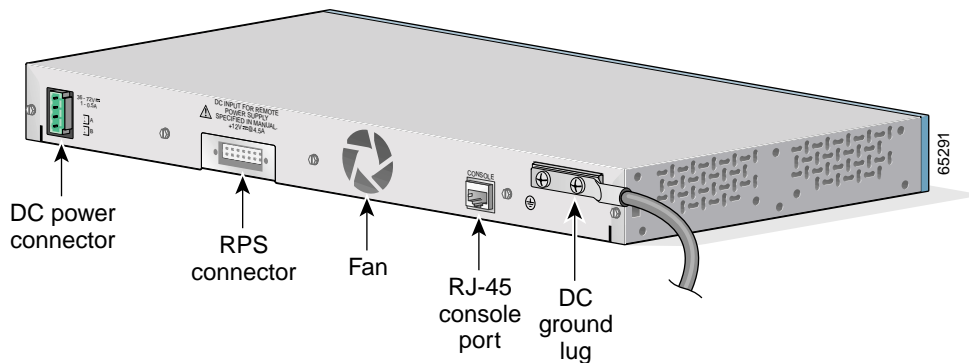
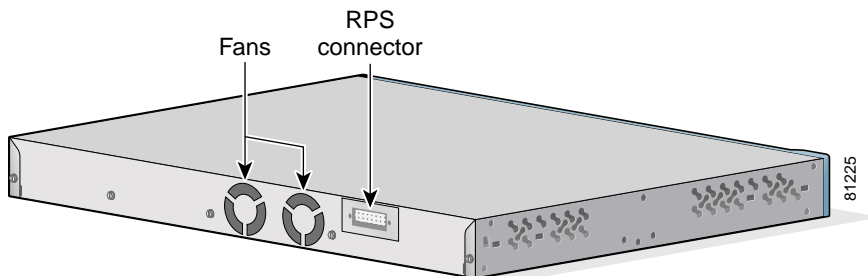


Figure 2-25 Catalyst 2950G-24-EI-DC Switch Rear Panel



**Figure 2-26** Catalyst 2950ST-8 LRE Switch, Catalyst 2950ST-24 LRE, and Catalyst 2950ST-24 LRE 997 Switch Rear Panel



## Power Connectors

You can provide power to a switch by using the AC internal power supply, the DC-input power source, or the Cisco RPS.

### Internal Power Supply Connector

The internal AC power supply is an autoranging unit that supports input voltages between 100 and 240 VAC. Other than for the Catalyst 2950G-24-EI-DC and the Catalyst 2950ST-24 LRE 997 switches, use the supplied AC power cord to connect the AC power connector to an AC power outlet.



#### Note

---

The AC power connector is on the front panel of the Catalyst 2950ST-8 LRE and Catalyst 2950ST-24 LRE switches.

---

You can order these L-shaped AC power cords from your Cisco sales representative:

- CAB-NP1200-AC-AR=
- CAB-NP1200-AC-AU=
- CAB-NP1200-AC-CH=
- CAB-NP1200-AC-EU=
- CAB-NP1200-AC-IT=

- CAB-NP1200-AC-JP=
- CAB-NP1200-AC-UK=
- CAB-NP1200-AC-US=

## DC Power Connector

The Catalyst 2950G-24-EI-DC and Catalyst 2950ST-24 LRE 997 switches have an internal DC-power converter. It has dual feeds (A and B) that are diode-OR-ed into a single power block. For installation instructions, see [Appendix C, “Connecting to DC Power.”](#)



### Caution

---

You must connect the Catalyst 2950G-24-EI-DC and 2950ST-24 LRE 997 switches only to a DC-input power source that has an input supply voltage from –36 to –72 VDC. If the supply voltage is not in this range, the switch might not operate properly or might be damaged.

---

## Cisco RPS Connector

Specific Cisco RPS models support specific Catalyst 2950 switches:

- Cisco RPS 300 (model PWR300-AC-RPS-N1)
- Cisco RPS 675 (model PWR675-AC-RPS-N1=)

### Cisco RPS 300

The Cisco RPS 300 has two output levels: –48V and 12V with a total maximum output power of 300W. Use the supplied RPS connector cable to connect the RPS to the switch.



### Warning

---

**Attach only the Cisco RPS 300 (model PWR300-AC-RPS-N1) to the RPS receptacle.**

---

The RPS is a 300W redundant power system that can support six external network devices and provides DC power to one failed device at a time. It automatically senses when the internal power supply of a connected device fails and provides power to that device, preventing loss of network traffic.

For more information, refer to the Cisco RPS 300 documentation.

## Cisco RPS 675

The Cisco RPS 675 has two output levels: –48V and 12V with a total maximum output power of 675W. Use the supplied RPS connector cable to connect the RPS to the switch.



### Warning

---

**Attach only the Cisco RPS 675 (model PWR675-AC-RPS-N1=) to the RPS receptacle.**

---

The RPS is a 675W redundant power system that can support six external network devices and provides DC power to one failed device at a time. It automatically senses when the internal power supply of a connected device fails and provides power to that device, preventing loss of network traffic.

For more information, refer to the Cisco RPS 675 documentation.

## Console Port

You can connect a switch to a PC through the console port and the supplied RJ-45-to-DB-9 adapter cable. If you want to connect a switch to a terminal, you need to provide an RJ-45-to-DB-25 female DTE adapter. You can order a kit (part number ACS-DSBUASYN=) with that adapter from Cisco. For console-port and adapter-pinout information, see the [“Cable and Adapter Specifications” section on page B-8](#).

# Management Options

Catalyst 2950 switches offer these management options:

- Cluster Management Suite (CMS)

CMS is made up of three web-based applications that you use to manage switches. You can use Cluster Builder, which includes Cluster View, and Cluster Manager to create, configure, and monitor switch clusters. You can also use Device Manager to manage individual and standalone switches. For more information, refer to the switch software configuration guide and the CMS online help.

- IOS command-line interface (CLI)

You can manage switches by using command-line entries. To access the CLI, connect a PC or a terminal directly to the console port on the switch. If the switch is attached to your network, you can use a Telnet connection to manage the switch from a remote location. For more information, refer to the switch command reference.

- CiscoView application

You can use the CiscoView device-management application to set configuration parameters and to view switch status and performance information. This application, which you purchase separately, can be a standalone application or part of an Simple Network Management Protocol (SNMP) network-management platform. For more information, refer to the documentation that came with your CiscoView application.

- SNMP network management

You can manage switches by using an SNMP-compatible management station running platforms such as HP OpenView and SunNet Manager. The switch supports a comprehensive set of management information base (MIB) extensions and MIB II, the IEEE 802.1D bridge MIB, and four Remote Monitoring (RMON) groups. For more information, refer to the documentation that came with your SNMP application.

- Cisco Intelligence Engine 2100 (IE2100)

The Cisco IE200 Series Configuration Registrar is a network management device that works with embedded Cisco Networking Services (CNS) agents in the switch software. You can automate initial configurations and configuration updates by generating switch-specific configuration changes, sending them to the switch, executing the configuration change, and logging the results. For more information, refer to the switch software configuration guide and the documentation that came with your application.







# Installation

---

This chapter describes how to install your switch, interpret the power-on self-test (POST), and connect the switch to other devices. Read these topics, and perform the procedures in this order:

- [Preparing for Installation, page 3-2](#)
- [Verifying Switch Operation, page 3-10](#)
- [Installing the Switch in a Rack, page 3-10](#)
- [Installing the Switch on a Table, Shelf, or Desk, page 3-22](#)
- [Installing the Switch on a Wall, page 3-23](#)
- [Installing the GBIC Modules, page 3-26](#)
- [Installing and Removing SFP Modules, page 3-28](#)
- [Connecting to 10/100 and 10/100/1000 Ports, page 3-32](#)
- [Connecting to 100BASE-FX and 1000BASE-SX Ports, page 3-36](#)
- [Connecting to an LRE Port, page 3-38](#)
- [Connecting to GBIC Module Ports, page 3-44](#)
- [Connecting to an SFP Module, page 3-49](#)
- [Where to Go Next, page 3-50](#)

# Preparing for Installation

This section provides information about these topics:

- [Warnings, page 3-2](#)
- [EMC Regulatory Statements, page 3-4](#)
- [Installation Guidelines, page 3-7](#)
- [Verifying Package Contents, page 3-8](#)

## Warnings

These warnings are translated into several languages in [Appendix D, “Translated Safety Warnings.”](#)



Warning

---

**This equipment is to be installed and maintained by service personnel only as defined by AS/NZS 3260 Clause 1.2.14.3 Service Personnel.**

---



Warning

---

**This unit is intended for installation in restricted access areas. A restricted access area can be accessed only through the use of a special tool, lock and key, or other means of security.**

---



Warning

---

**Only trained and qualified personnel should be allowed to install or replace this equipment.**

---



Warning

---

**Read the installation instructions before you connect the system to its power source.**

---



Warning

---

**Unplug the power cord before you work on a system that does not have an on/off switch.**

---



Warning

Do not stack the chassis on any other equipment. If the chassis falls, it can cause severe bodily injury and equipment damage.



Warning

To comply with safety regulations, mount switches on a wall with the front panel facing up.



Warning

If a redundant power system (RPS) is not connected to the switch, install an RPS connector cover on the back of the switch.



Warning

The plug-socket combination must be accessible at all times because it serves as the main disconnecting device.



Warning

To prevent the switch from overheating, do not operate it in an area that exceeds the maximum recommended ambient temperature of 113°F (45°C). To prevent airflow restriction, allow at least 3 inches (7.6 cm) of clearance around the ventilation openings.



Warning

When installing the unit, always make the ground connection first and disconnect it last.



Warning

This equipment is intended to be grounded. Ensure that the host is connected to earth ground during normal use.



Warning

Before working on equipment that is connected to power lines, remove jewelry (including rings, necklaces, and watches). Metal objects will heat up when connected to power and ground and can cause serious burns or weld the metal object to the terminals.

**Warning**

Do not work on the system or connect or disconnect cables during periods of lightning activity.

**Warning**

Ultimate disposal of this product should be handled according to all national laws and regulations.

**Warning**

Attach only the Cisco RPS (model PWR300-AC-RPS-N1) to the RPS receptacle.

**Warning**

Invisible laser radiation may be emitted from disconnected fibers or connectors. Do not stare into beams or view directly with optical instruments.

**Warning**

Class 1 laser product

**Warning**

Avoid direct exposure to the laser beam

## EMC Regulatory Statements

This section includes specific regulatory statements about the Catalyst 2950 switches.

### U.S.A.

U.S. regulatory information for this product is in the front matter of this manual.

## Taiwan



### Warning

This is a Class A Information Product, when used in residential environment, it may cause radio frequency interference, under such circumstances, the user may be requested to take appropriate countermeasures.

### 警告

這是甲類資訊產品，在居住環境中使用時，可能會造成射頻干擾，在這種情況下，使用者會被要求採取某些適當的對策。

## Japan

This is a Class A product based on the standard of the Voluntary Control Council for Interference by Information Technology Equipment (VCCI). If this equipment is used in a domestic environment, radio disturbance may arise. When such trouble occurs, the user may be required to take corrective actions.

この装置は、情報処理装置等電波障害自主規制協議会（VCCI）の基準に基づくクラスA情報技術装置です。この装置を家庭環境で使用すると電波妨害を引き起こすことがあります。この場合には使用者が適切な対策を講ずるよう要求されることがあります。

46464

## Korea



Warning

This is a Class A Device and is registered for EMC requirements for industrial use. The seller or buyer should be aware of this. If this type was sold or purchased by mistake, it should be replaced with a residential-use type.

주의 A급 기기 이 기기는 업무용으로 전자파 적합 등록을 한 기기이  
오니 판매자 또는 사용자는 이 점을 주의하시기 바라며 만약  
잘못 판매 또는 구입하였을 때에는 가정용으로 교환하시기 바랍니다.

## Hungary



Warning

This equipment is a class A product and should be used and installed properly according to the Hungarian EMC Class A requirements (MSZEN55022). Class A equipment is designed for typical commercial establishments for which special conditions of installation and protection distance are used.

Figyelmeztetés Figyelmeztetés a felhasználói kézikönyv számára: Ez a berendezés "A"  
osztályú termék, felhasználására és üzembe helyezésére a magyar EMC "A"  
osztályú követelményeknek (MSZ EN 55022) megfelelően kerülhet sor, illetve  
ezen "A" osztályú berendezések csak megfelelő kereskedelmi forrásból  
származhatnak, amelyek biztosítják a megfelelő speciális üzembe helyezési  
körülményeket és biztonságos üzemelési távolságok alkalmazását.

## Installation Guidelines

When determining where to place the switch, observe these guidelines.

- Before installing the switch, first verify that the switch is operational by powering it on and running POST. Follow the procedures in the [“Verifying Switch Operation” section on page 3-10](#).
- For 10/100 ports and 10/100/1000 ports, the cable length from a switch to an attached device cannot exceed 328 feet (100 meters).
- For 100BASE-FX ports, the cable length from a switch to an attached device cannot exceed 6562 feet (2 kilometers).
- For 1000BASE-SX ports and 1000BASE-SX Gigabit Interface Converter (GBIC) module ports, the cable length from a switch to an attached device cannot exceed 1804 feet (550 meters).
- For 1000BASE-LX/LH GBIC module ports, the cable length from a switch to an attached device cannot exceed 32,810 feet (10 kilometers).
- For 1000BASE-ZX GBIC module ports, the cable length from a switch to an attached device cannot exceed 328,100 feet (100 kilometers).
- For 1000BASE-T GBIC module ports, the cable length from a switch to an attached device cannot exceed 328 feet (100 meters).
- For Coarse Wave Division Multiplexing (CWDM) GBIC module ports, the cable length from a switch to an attached device cannot exceed 393,719 feet (120 kilometers). For specific cable lengths, refer to the CWDM GBIC module documentation.
- For GigaStack GBIC module ports, the cable length from a switch to an attached device cannot exceed 3 feet (1 meter).
- For Long-Reach Ethernet (LRE) ports, cable-length specifications vary. See the [“LRE Port” section on page 2-12](#).
- Operating environment is within the ranges listed in [Appendix A, “Technical Specifications.”](#)
- Clearance to front and rear panels meet these conditions:
  - Front-panel LEDs can be easily read.
  - Access to ports is sufficient for unrestricted cabling.
  - Rear-panel AC power connector on switches other than the LRE switches is within reach of an AC power outlet.

- Rear-panel direct current (DC) power connector on the Catalyst 2950G-24-EI-DC switch is within reach of a circuit breaker.
- Front-panel AC power connector on the LRE switches is within reach of an AC power outlet.
- Front-panel DC power connector on the Catalyst 2950ST-24 LRE 997 switch is within reach of a circuit breaker.
- Airflow around the switch and through the vents is unrestricted.
- Temperature around the unit does not exceed 113°F (45°C).




---

**Note** If the switch is installed in a closed or multitrack assembly, the temperature around it might be greater than normal room temperature.

---

- Cabling is away from sources of electrical noise, such as radios, power lines, and fluorescent lighting fixtures.

## Verifying Package Contents



### Note

---

Carefully remove the contents from the shipping container, and check each item for damage. If any item is missing or damaged, contact your Cisco representative or reseller for support. Return all packing materials to the shipping container and save them.

---

The switch is shipped with these items:

- This *Catalyst 2950 Desktop Switch Hardware Configuration Guide*
- *About the Catalyst 2950 and Catalyst 2955 Documentation*
- AC power cord (not shipped with the Catalyst 2950G-24-EI-DC switch or the Catalyst 2950ST-24 LRE 997 switch)
- Mounting kit containing these items:
  - Four rubber feet for mounting the switch on a table, shelf, or desk
  - Two 19-inch or 24-inch rack-mounting brackets



- Six number-8 Phillips flat-head screws for attaching the brackets to the switch
- Four number-8 Phillips truss-head screws for attaching the brackets to the switch
- Four number-12 Phillips machine screws for attaching the brackets to a rack
- One cable guide and one black Phillips machine screw for attaching the cable guide to one of the mounting brackets
- One RPS connector cover and two number-4 pan-head screws
- DC-switch kit containing these items:
  - One DC terminal block plug (also called a terminal block header)
  - One ground lug
  - Two number-10-32 screws for attaching the ground lug to the switch
  - Two 23-inch rack-mounting brackets (with 1-inch spacing for telco racks)
  - Four number-8 Phillips truss-head screws for attaching the brackets to the switch
  - Two number-12 Phillips machine screws for attaching the brackets to a rack



---

**Note** The DC-switch kit ships only with the Catalyst 2950G-24-EI-DC or Catalyst 2950ST-24 LRE 997 switch.

---

- One RJ-45-to-DB-9 adapter cable
- Product ownership registration card

If you want to connect a terminal to the switch console port, you need to provide an RJ-45-to-DB-25 female DTE adapter. You can order a kit (part number ACS-DSBUASYN=) with that adapter from Cisco.

# Verifying Switch Operation

Before installing the switch in a rack, on a wall, or on a table or shelf, you should power on the switch and verify that the switch passes POST. See [Chapter 1, “Quick Installation,”](#) for the steps required to connect a PC to the switch console port and to power on the switch.

After a successful POST, follow these steps:

- 
- Step 1** Turn off power to the switch.
- Step 2** Disconnect the cables.
- Step 3** Determine where you want to install the switch.
- 

# Installing the Switch in a Rack



## Warning

To prevent bodily injury when mounting or servicing this unit in a rack, you must take special precautions to ensure that the system remains stable. The following guidelines are provided to ensure your safety:

- This unit should be mounted at the bottom of the rack if it is the only unit in the rack.
- When mounting this unit in a partially filled rack, load the rack from the bottom to the top with the heaviest component at the bottom of the rack.
- If the rack is provided with stabilizing devices, install the stabilizers before mounting or servicing the unit in the rack.



## Note

[Figure 3-1](#) to [Figure 3-20](#) show the Catalyst 2950-24, 2950G-24-EI-DC, and 2950G-48-EI switches as examples. You can install other Catalyst 2950 switches in a rack as shown in these illustrations.

To install the switch in a 19-, 23-, or 24-inch rack, follow these steps:

1. [Attaching the Brackets to the Switch, page 3-11](#)
2. [Mounting the Switch in a Rack, page 3-21](#)
3. [Attaching the Optional Cable Guide, page 3-22](#)

**Note**

Installing the Catalyst 2950G-48-EI switch in a 23-inch or 24-inch rack requires an optional bracket kit not included with the switch. You can order a kit containing the 23-inch or 24-inch rack-mounting brackets and hardware from Cisco (part number RCKMNT-1RU=).

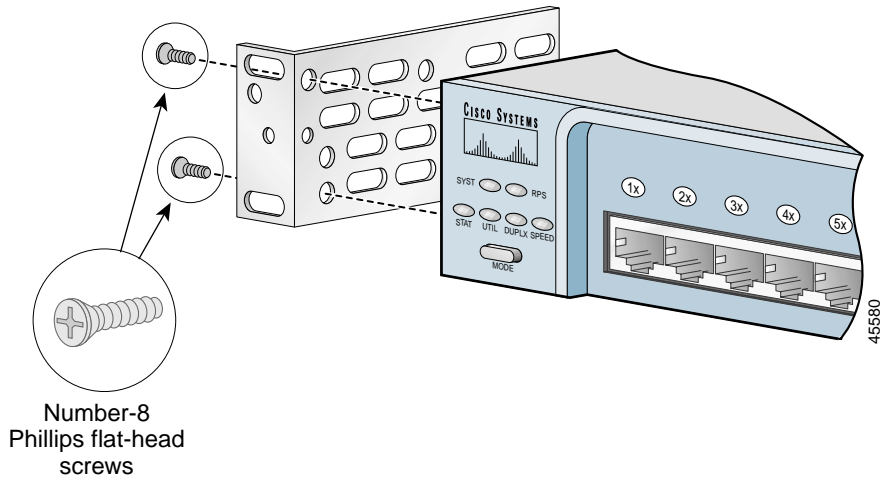
## Attaching the Brackets to the Switch

The bracket orientation and the screws that you use depend on whether you are attaching the brackets to a 19-, 23-, or 24-inch rack. Follow these guidelines:

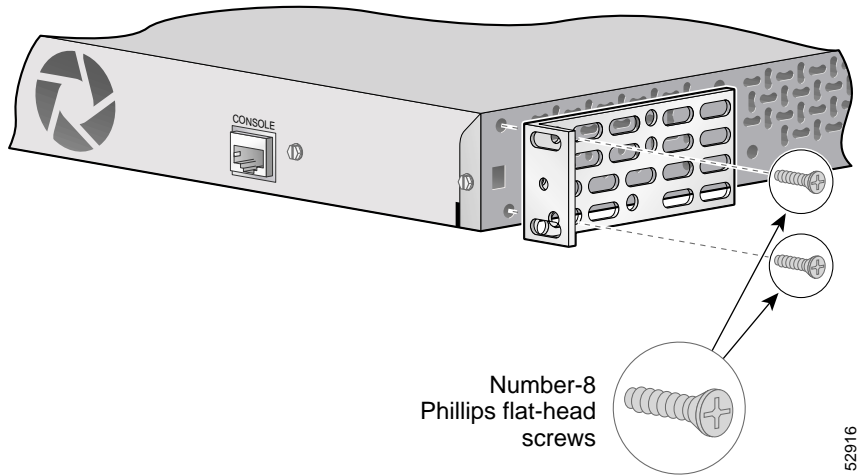
- When mounting a switch other than a Catalyst 2950G-48-EI switch in a 19-inch rack, use two Phillips flat-head screws to attach the long side of the 19- or 24-inch bracket to the switch. See [Figure 3-1](#), [Figure 3-2](#), and [Figure 3-3](#).
- When mounting a Catalyst 2950G-48-EI switch in a 19-inch rack, use three Phillips flat-head screws to attach the long side of the 19- or 24-inch bracket to the switch. See [Figure 3-4](#), [Figure 3-5](#), and [Figure 3-6](#).
- When mounting a Catalyst 2950G-24-EI-DC or Catalyst 2950ST-24 LRE 997 switch in a 23-inch rack, use two Phillips truss-head screws to attach the 23-inch bracket to the switch. See [Figure 3-7](#), [Figure 3-8](#), and [Figure 3-9](#).
- When mounting a switch other than a Catalyst 2950G-48-EI switch in a 24-inch rack, use two Phillips truss-head screws to attach the 19- or 24-inch bracket to the switch. See [Figure 3-10](#), [Figure 3-11](#), and [Figure 3-12](#).
- When mounting a Catalyst 2950G-48-EI switch in a 24-inch rack, use three Phillips flat-head screws to attach the 24-inch bracket (part number RCKMNT-1RU=) to the switch. See [Figure 3-13](#), [Figure 3-14](#), and [Figure 3-15](#).

Figure 3-1 to Figure 3-15 show how to attach a bracket to one side of the switch. Follow the same steps to attach the second bracket to the opposite side of the switch.

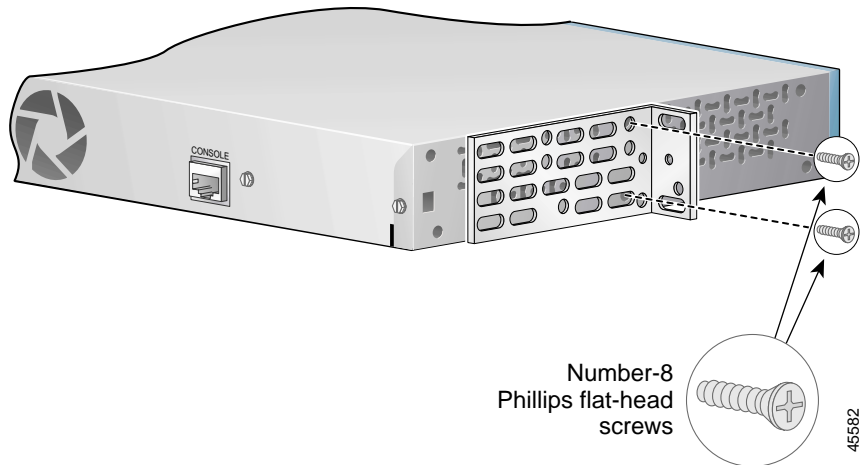
**Figure 3-1 Attaching Brackets on the Switch in a 19-Inch Rack (Front Panel Forward)**



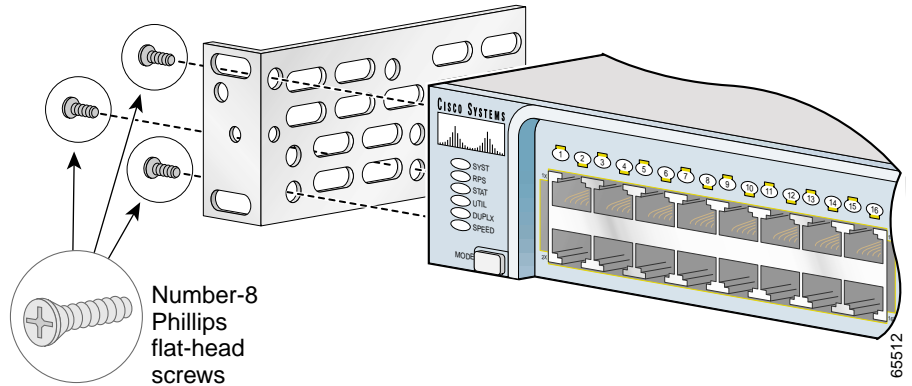
**Figure 3-2 Attaching Brackets on the Switch in a 19-Inch Rack (Rear Panel Forward)**



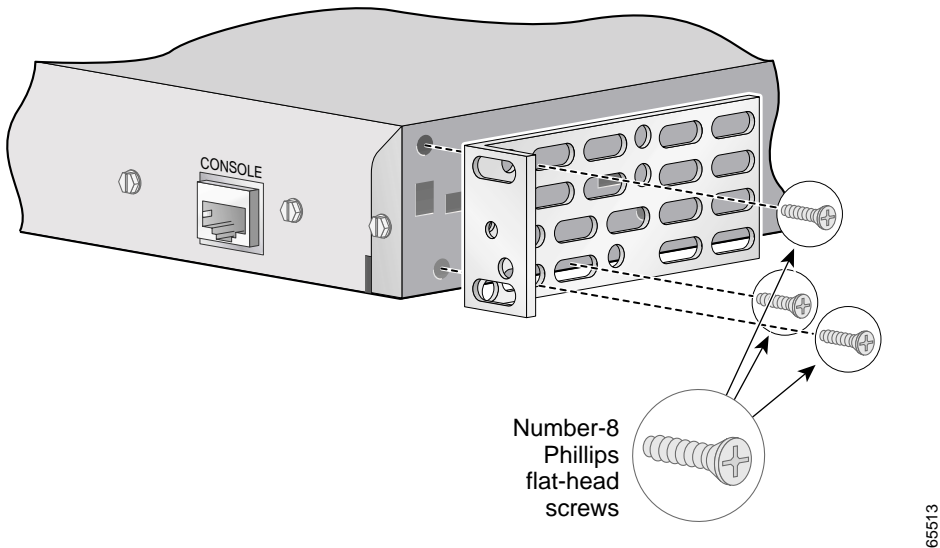
**Figure 3-3 Attaching Brackets on the Switch in a 19-Inch Telco Rack**



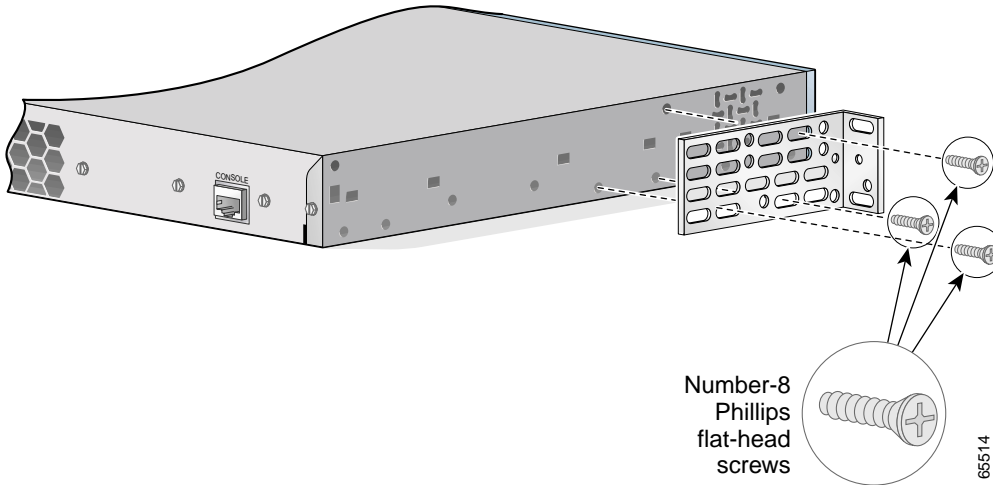
**Figure 3-4 Attaching Brackets on the Catalyst 2950G-48-EI Switch in a 19-Inch Rack (Front Panel Forward)**



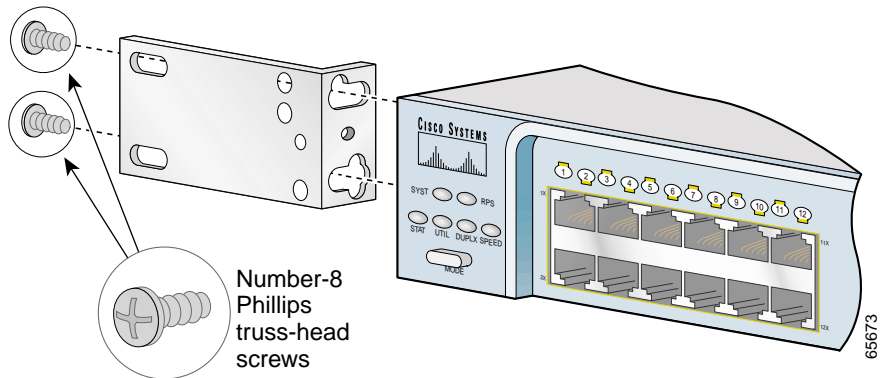
**Figure 3-5 Attaching Brackets on the Catalyst 2950G-48-EI Switch in a 19-Inch Rack (Rear Panel Forward)**



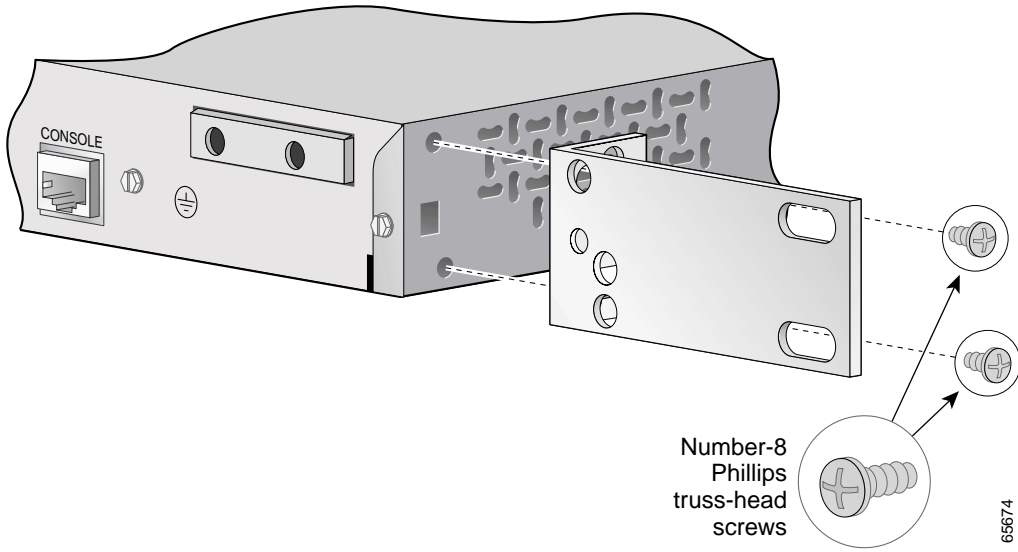
**Figure 3-6** Attaching Brackets on the Catalyst 2950G-48-EI Switch in a 19-Inch Telco Rack



**Figure 3-7** Attaching Brackets on the Catalyst 2950G-24-EI-DC or 2950ST-24 LRE 997 Switch in a 23-Inch Telco Rack (Front Panel Forward)

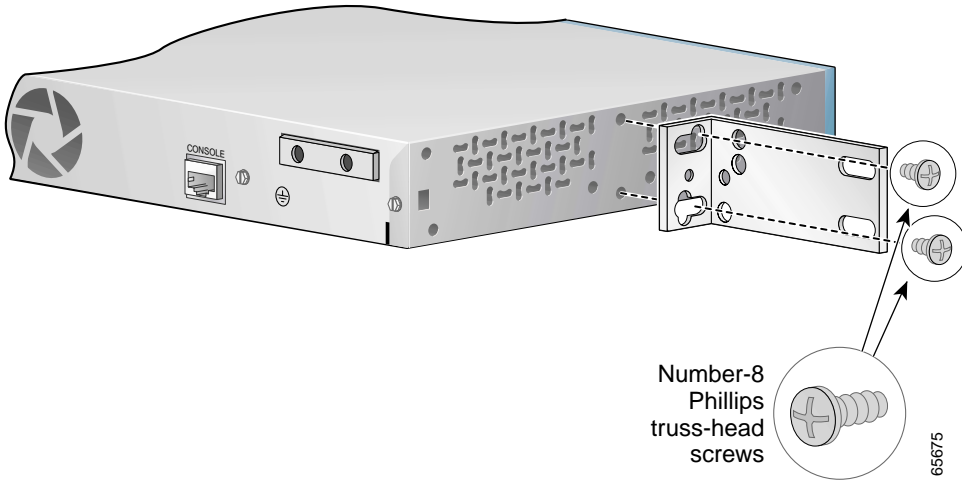


**Figure 3-8** Attaching Brackets on the Catalyst 2950G-24-EI-DC or 2950ST-24 LRE 997 Switch in a 23-Inch Telco Rack (Rear Panel Forward)

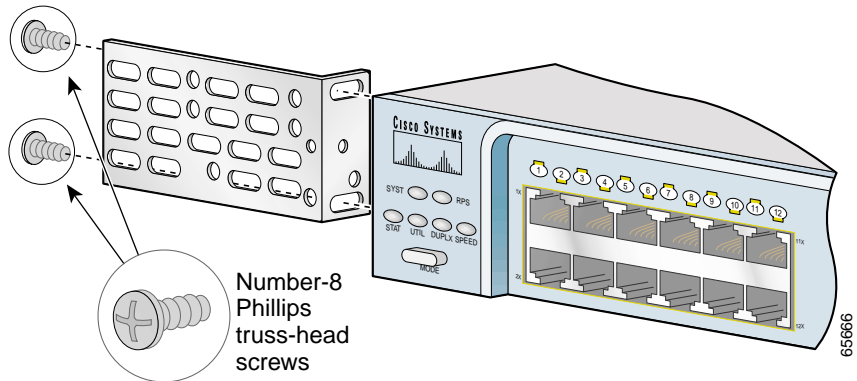




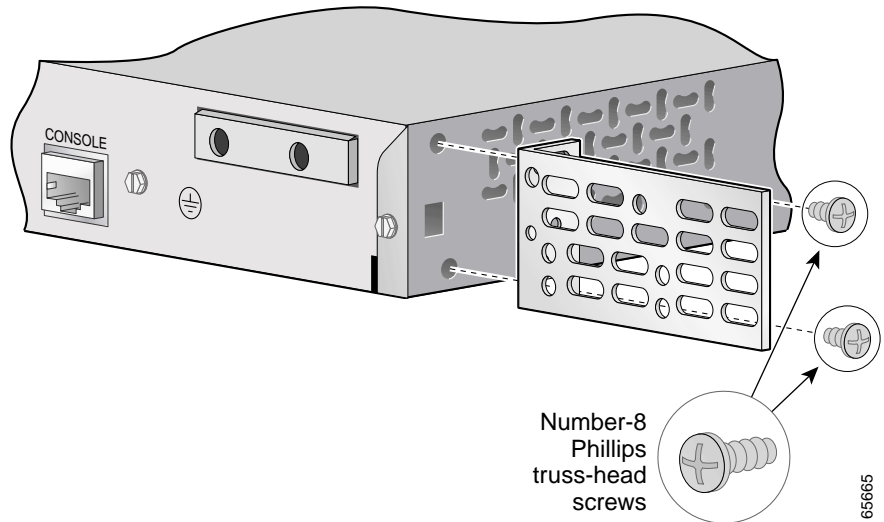
**Figure 3-9 Attaching Brackets on the Catalyst 2950G-24-EI-DC or 2950ST-24 LRE 997 Switch in a 23-Inch Telco Rack**



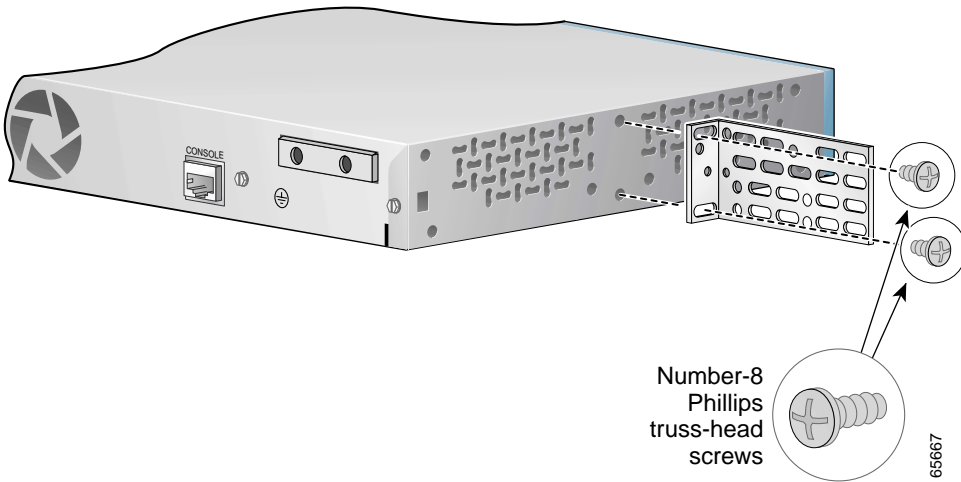
**Figure 3-10 Attaching Brackets on the Switch in a 24-Inch Rack (Front Panel Forward)**



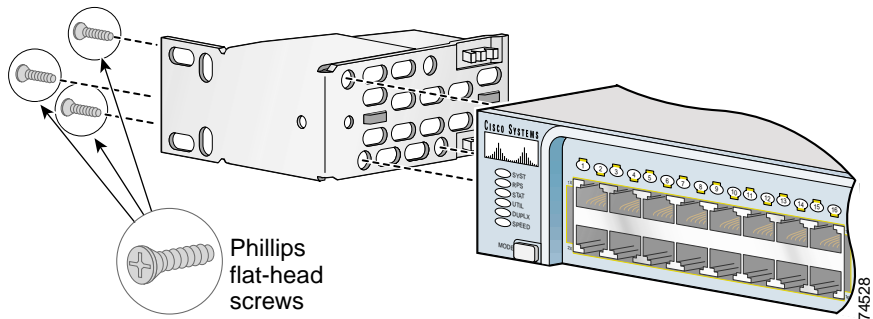
**Figure 3-11 Attaching Brackets on the Switch in a 24-Inch Rack (Rear Panel Forward)**



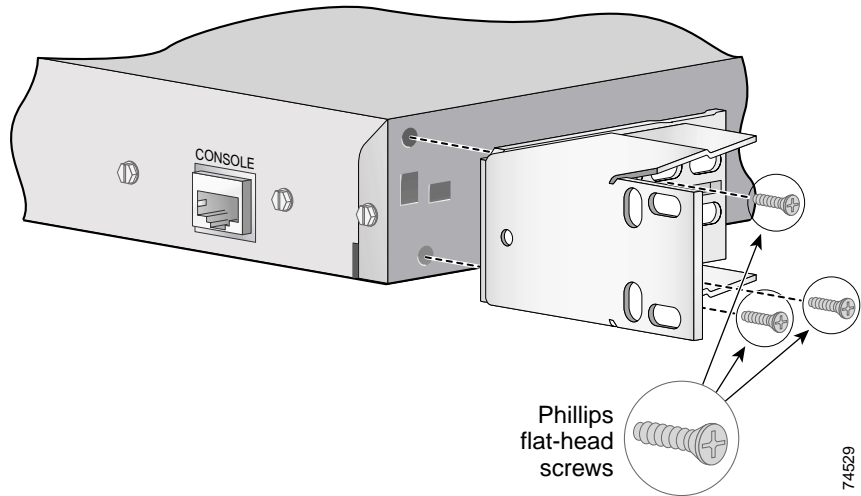
**Figure 3-12** Attaching Brackets on the Switch in a 24-Inch Telco Rack



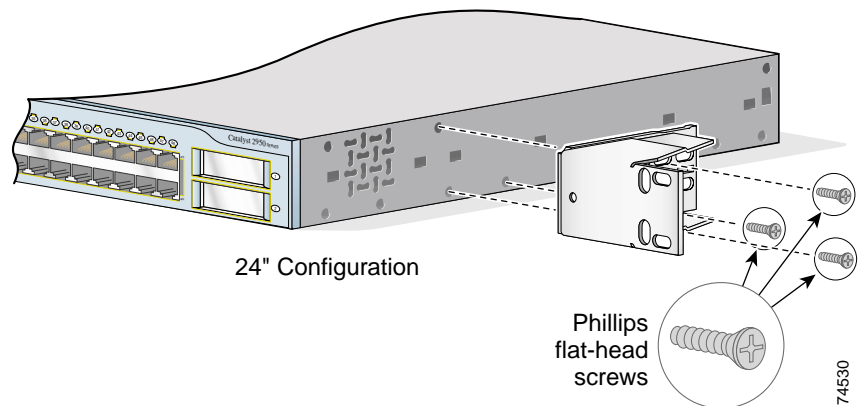
**Figure 3-13** Attaching Brackets on the Catalyst 2950G-48-EI Switch in a 24-Inch Rack (Front Panel Forward)



**Figure 3-14 Attaching Brackets on the Catalyst 2950G-48-EI Switch in a 24-Inch Rack (Rear Panel Forward)**



**Figure 3-15 Attaching Brackets on the Catalyst 2950G-48-EI Switch in a 24-Inch Telco Rack**

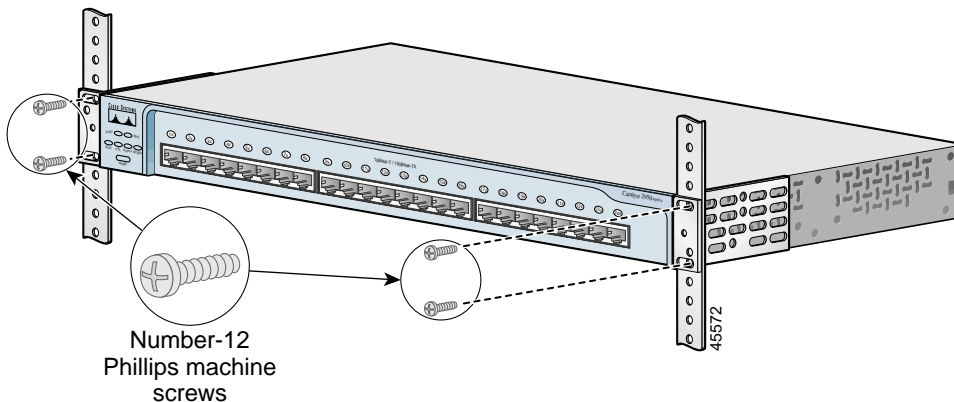


## Mounting the Switch in a Rack

After attaching the brackets, use the four Phillips machine screws to securely attach the brackets to the rack, as shown in [Figure 3-16](#).

When installing a switch other than an LRE switch, to prevent the cables from obscuring the switch and other devices in the rack, you can also attach the cable guide to the rack. See the [“Attaching the Optional Cable Guide”](#) section for instructions.

*Figure 3-16 Mounting the Switch in a Rack*



After mounting the switch in the rack, start the terminal-emulation software, and provide power to the switch. See [Chapter 1, “Quick Installation”](#) for instructions.

## Attaching the Optional Cable Guide

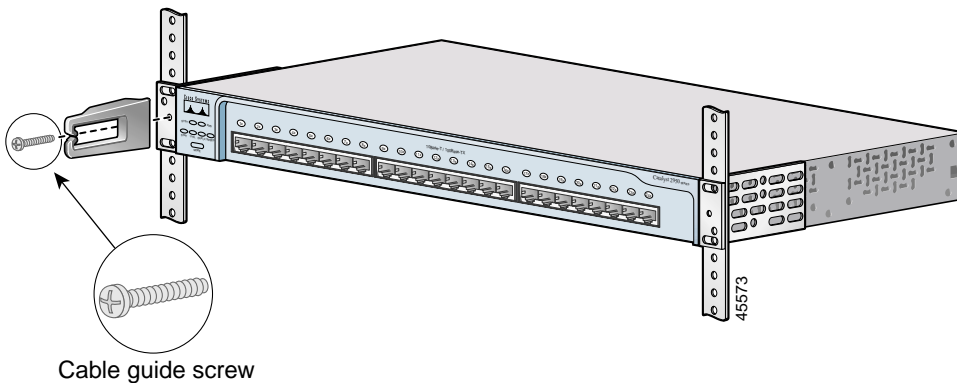
We recommend attaching the cable guide to prevent the cables from obscuring the front panels of the switch and other devices installed in the rack. Use the supplied black Phillips machine screw to attach the cable guide to the left or right bracket, as shown in [Figure 3-17](#).



**Note**

You cannot use the cable guide with Catalyst 2950 LRE switches.

**Figure 3-17** Attaching the Cable Guide



Cable guide screw

## Installing the Switch on a Table, Shelf, or Desk

Before placing the switch on a table, shelf, or desk, locate the adhesive strip with rubber feet in the mounting-kit envelope, and attach four rubber feet to the recessed areas on the switch bottom. Place the switch on a table, shelf, or desk near an AC power source or DC-input power source.

Start the terminal-emulation software and provide power to the switch. See [Chapter 1, “Quick Installation,”](#) for instructions.

# Installing the Switch on a Wall



Warning

---

To comply with safety regulations, mount switches on a wall with the front panel facing up.

---



Warning

---

If a redundant power system (RPS) is not connected to the switch, install an RPS connector cover on the back of the switch.

---

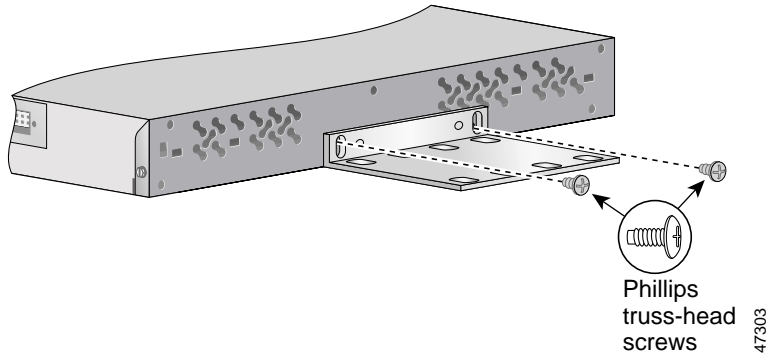
You can mount the Catalyst 2950 switch to a wall in a face-up configuration. To attach the switch to a wall, follow the procedures in this section.

1. [Attaching the Brackets to the Switch, page 3-23](#)
2. [Attaching the RPS Connector Cover, page 3-24](#)
3. [Mounting the Switch to a Wall, page 3-25](#)

## Attaching the Brackets to the Switch

Use the supplied Phillips flat-head screws to attach a bracket to the switch. [Figure 3-18](#) shows how to attach the bracket to one side of the switch. Follow the same steps to attach the second bracket to the opposite side of the switch.

*Figure 3-18 Attaching Brackets for Wall-Mounting for the Catalyst 2950 Switch*



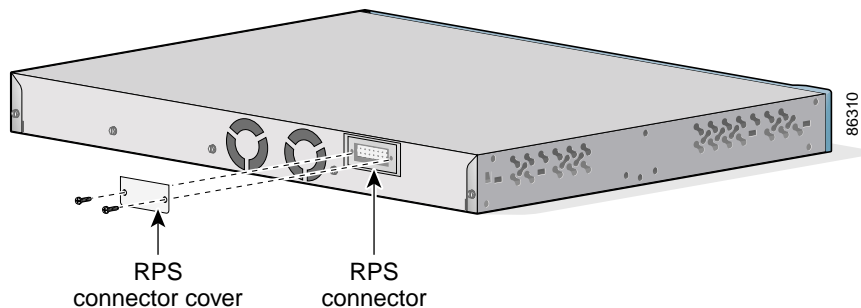
## Attaching the RPS Connector Cover

If you are not using a redundant power system (RPS) with your switch, use two number-4 Phillips pan-head screws to install an RPS connector cover to the back of the switch. (See [Figure 3-19](#).) The pan-head screws are included in the accessory kit.



If an RPS is not connected to the switch, install an RPS connector cover on the back of the switch.

*Figure 3-19 Attaching the RPS Connector Cover*





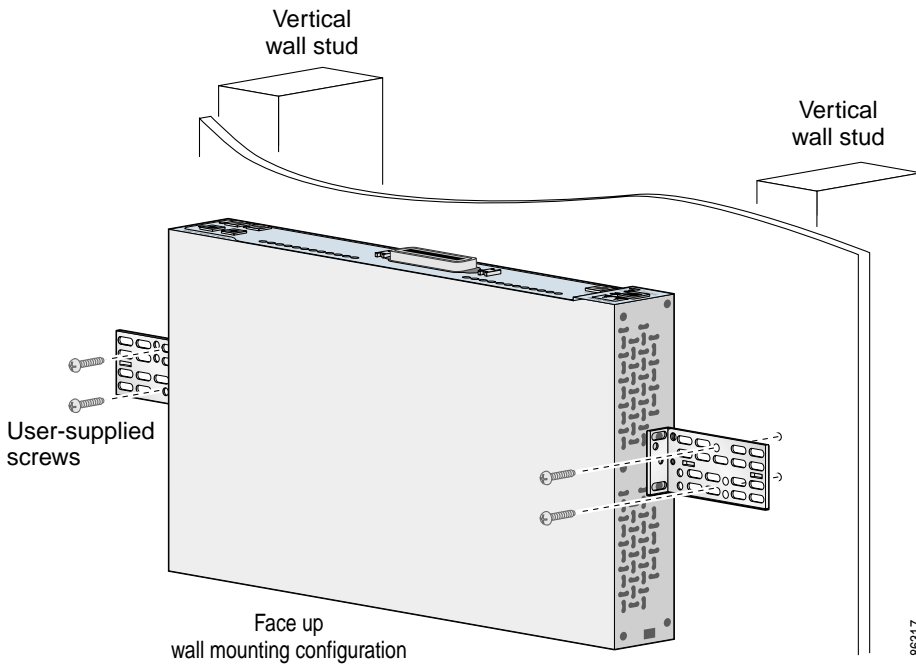
# Mounting the Switch to a Wall

**Warning**

To comply with safety regulations, mount switches on a wall with the front panel facing up.

For the best support of the switch and cables, make sure the switch is attached securely to a wall stud or to a firmly attached plywood mounting backboard, as shown in [Figure 3-20](#).

*Figure 3-20 Mounting a Catalyst 2950 Switch to a Wall*



After the switch is mounted on the wall, power the switch as described in [Chapter 1, “Quick Installation.”](#)

# Installing the GBIC Modules

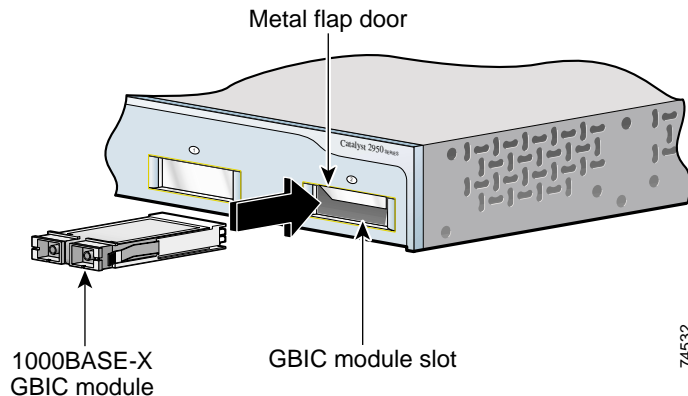
Figure 3-21, Figure 3-22, and Figure 3-23 show how to insert a GBIC module in a GBIC module slot on the switch. For instructions on how to install a CWDM GBIC module in a GBIC module slot, refer to the documentation that came with that GBIC module.

For detailed instructions on installing, removing, and cabling the GBIC module (the 1000BASE-X module, the 1000BASE-T module, the CWDM GBIC module, or the GigaStack module), refer to your GBIC documentation.

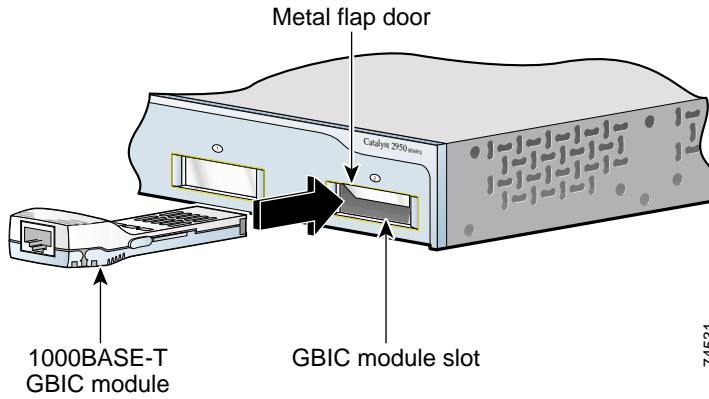
**Caution**

To prevent electrostatic-discharge (ESD) damage when installing GBIC modules, follow your normal board and component handling procedures.

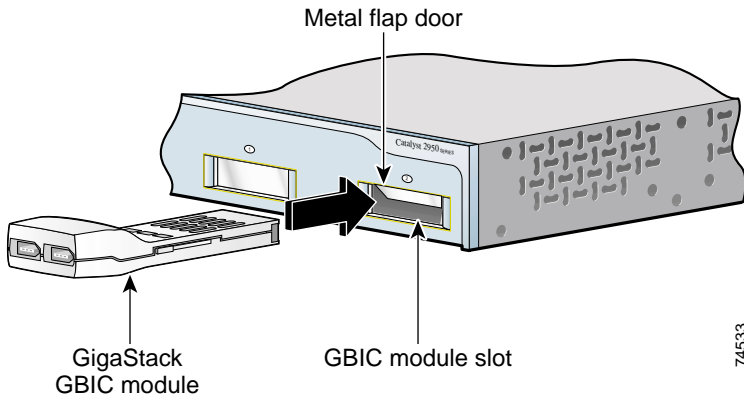
*Figure 3-21 Installing a 1000BASE-X GBIC Module in a Switch*



**Figure 3-22** *Installing a 1000BASE-T GBIC Module in a Switch*



**Figure 3-23** *Installing a GigaStack GBIC Module in a Switch*



# Installing and Removing SFP Modules

These sections describe how to install and remove small-form-factor pluggable (SFP) modules. SFP modules are inserted into SFP module slots on the front of the Catalyst 2950 LRE switches. These field-replaceable modules provide the uplink optical interfaces, laser send (TX) and laser receive (RX).

You can use any combination of SFP modules. Refer to the Catalyst 2950 LRE release notes for the list of SFP modules that the Catalyst 2950 LRE switch supports. Each port must match the wave-length specifications on the other end of the cable, and the cable must not exceed the stipulated cable length for reliable communications. Refer to [Table 2-2](#) for cable stipulations for SFP connections.

Use only Cisco SFP modules on the Catalyst 2950 LRE switch. Each SFP module has an internal serial EEPROM that is encoded with security information. This encoding provides a way for Cisco to identify and validate that the SFP module meets the requirements for the switch.

For detailed instructions on installing, removing, and cabling the SFP module, refer to your SFP module documentation.

## Installing SFP Modules into SFP Module Slots

SFP modules use different types of latches for their installation and extraction. Determine which type of latch your SFP module uses before following the installation procedure:

- [Figure 3-24](#) shows an SFP module with a Mylar tab latch.
- [Figure 3-25](#) shows an SFP module with an actuator button latch.
- [Figure 3-26](#) shows an SFP module that has a bale-clasp latch.

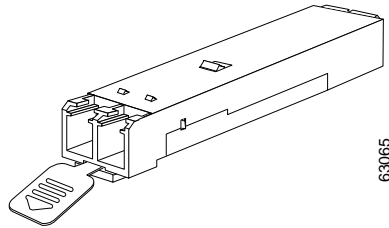


### Caution

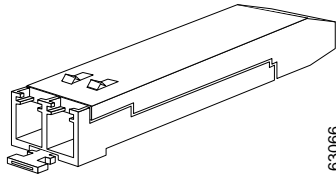
We strongly recommend that you do not install or remove the SFP module with fiber-optic cables attached to it because of the potential damage to the cables, the cable connector, or the optical interfaces in the SFP module. Disconnect all cables before removing or installing an SFP module.

Removing and installing an SFP module can shorten its useful life. Do not remove and insert SFP modules more often than is absolutely necessary.

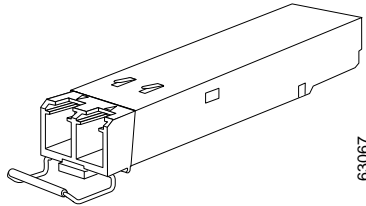
**Figure 3-24 SFP Module with a Mylar Tab Latch**



**Figure 3-25 SFP Module with an Actuator Button Latch**



**Figure 3-26 SFP Module with a Bale-Clasp Latch**



To insert an SFP module into the SFP module slot, follow these steps:

- 
- Step 1** Attach an ESD-preventive wrist strap to your wrist and to a bare metal surface on the chassis.
  - Step 2** Find the send (TX) and receive (RX) markings that identify the top side of the SFP module.

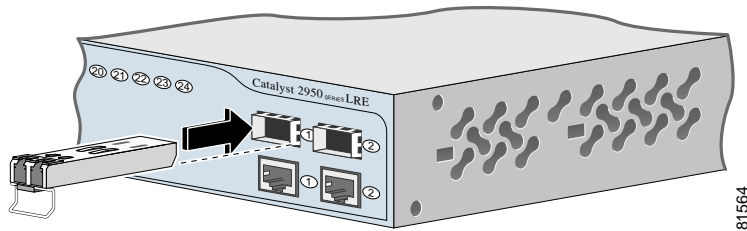


**Note** On some SFP modules, the send and receive (TX and RX) markings might be replaced by arrows that show the direction of the connection, either send or receive (TX or RX).

---

- Step 3** Align the SFP module in front of the slot opening.
- Step 4** Insert the SFP module into the slot until you feel the connector on the module snap into place in the rear of the slot.

*Figure 3-27 Installing an SFP Module into an SFP Module Slot*



- Step 5** Remove the dust plugs from the SFP module optical ports and store them for later use.



**Caution**

Do not remove the dust plugs from the SFP module port or the rubber caps from the fiber-optic cable until you are ready to connect the cable. The plugs and caps protect the SFP module ports and cables from contamination and ambient light.

- Step 6** Insert the LC into the SFP module.

## Removing SFP Modules from SFP Module Slots

To remove an SFP module from a module receptacle, follow these steps:

- Step 1** Attach an ESD-preventive wrist strap to your wrist and to a bare metal surface on the chassis.
- Step 2** Disconnect the LC from the SFP module.

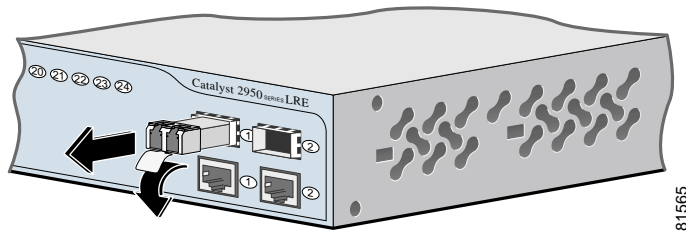


**Tip**

For reattachment, note which cable connector plug is send (TX) and which is receive (RX).

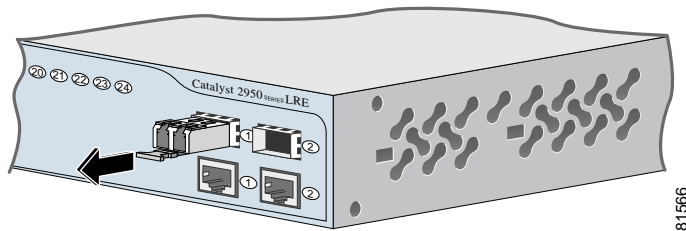
- Step 3** Insert a dust plug into the optical ports of the SFP module to keep the optical interfaces clean.
- Step 4** Unlock and remove the SFP module, as shown in [Figure 3-28](#), [Figure 3-29](#), and [Figure 3-30](#).
- If the module has a Mylar tab latch, pull the tab straight out so that you remove the SFP module from the port in a parallel direction. Do not twist or pull the tab because you could disconnect it from the SFP module.

**Figure 3-28** Using the Mylar Tab Latch to Remove an SFP Module from a Slot



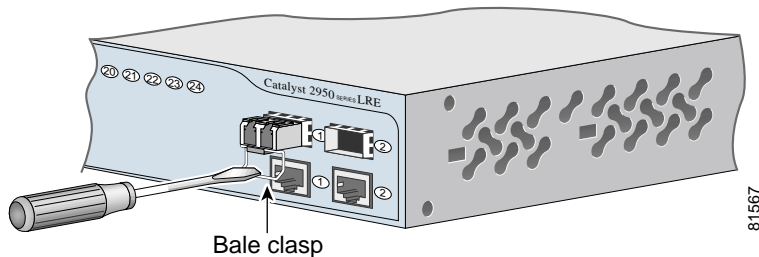
- If the module has an actuator button latch, use your thumb to push inward on the wedge to free the locking pin, and use your index finger to grip the ridge on top of the SFP module. Pull straight out to remove the module.

**Figure 3-29** Using the Actuator Button Latch to Remove an SFP Module from an SFP Module Slot



- If the module has a bale-clasp latch, pull the bale out and down to eject the module. If the bale-clasp latch is obstructed and you cannot use your index finger to open it, use a small, flat-blade screwdriver or other long, narrow instrument to open the bale-clasp latch.

**Figure 3-30** Removing a Bale-Clasp Latch SFP Module by Using a Flat-Blade Screwdriver



- Step 5** Grasp the SFP module between your thumb and index finger, and carefully remove it from the module slot.
- Step 6** Place the removed SFP module in an antistatic bag or other protective environment.

## Connecting to 10/100 and 10/100/1000 Ports

The 10/100 ports configure themselves to operate at the speed and duplex settings of attached devices. They operate at 10 or 100 Mbps in half- or full-duplex mode. If the attached devices do not support autonegotiation, you can explicitly set the speed and duplex parameters.

The 10/100/1000 ports configure themselves to operate at the speed setting of attached devices. These ports on Catalyst 2950T-24 switches operate at 10, 100, or 1000 Mbps in full-duplex mode. The 10/100/1000 ports on Catalyst 2950 LRE switches operate at 10 or 100 Mbps in either half- or full-duplex mode and at 1000 Mbps only in full-duplex mode. If the attached devices do not support autonegotiation, you can set the speed.



**Note**

---

On the Catalyst 2950 LRE switches, the four input uplink ports are bundled as two logical ports, each consisting of a copper 10/100/1000 port and a fiber-optic SFP module slot, respectively.

Within each logical port, you can use only the copper or the fiber-optic port at one time. If the Catalyst 2950 LRE switch senses more than two connections for both logical ports, by default, the switch chooses the fiber-optic connections over the copper connections.

See the [“SFP Module Slots” section on page 2-14](#) for more information on LRE uplink logical ports.

---

Connecting devices that do not autonegotiate or devices with manually set speed and duplex parameters can reduce performance or result in link failures between the devices. To maximize performance, choose one of these methods for configuring the ports:

- Let the 10/100 ports autonegotiate both speed and duplex, let the 10/100/1000 ports on the LRE switches autonegotiate both speed and duplex, and let the 10/100/1000 ports on the Catalyst 2950G-24-EI-DC switch only autonegotiate speed.
- Set the speed and duplex parameters on both ends of the connection.

When connecting the ports on the Catalyst 2950G-24-EI-DC and Catalyst 2950ST-24 LRE 997 switches to other devices, follow these guidelines:

**Caution**

---

To comply with the intrabuilding lightning surge requirements, intrabuilding wiring must be shielded, and the shield for the wiring must be grounded at both ends.

---

**Caution**

---

The Catalyst 2950G-24-EI-DC or Catalyst 2950ST-24 LRE 997 switch is suitable only for intrabuilding or nonexposed wiring connections.

---

Follow these steps to connect the switch to 10BASE-T, 100BASE-TX, or 1000BASE-T devices:


**Caution**

To prevent electrostatic-discharge (ESD) damage, follow your normal board and component handling procedures.

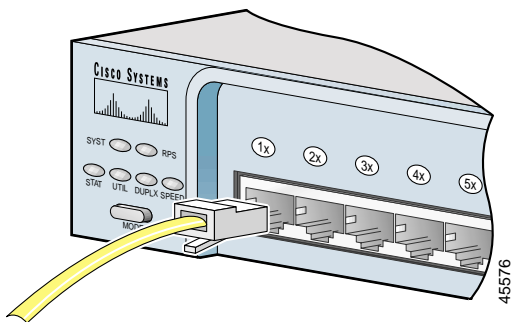
**Step 1**

When connecting to servers, workstations, and routers, insert a twisted-pair straight-through cable in a front-panel RJ-45 connector, as shown in [Figure 3-31](#), [Figure 3-32](#), and [Figure 3-33](#). When connecting to switches or repeaters, insert a twisted-pair crossover cable. (See the “[Cable and Adapter Specifications](#)” section on [page B-8](#) for cable-pinout descriptions.)

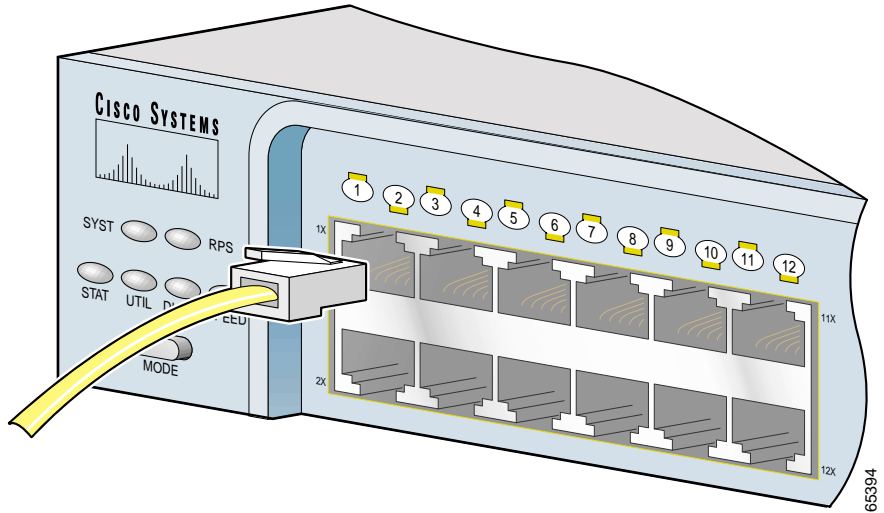

**Note**

When connecting to 1000BASE-T devices, be sure to use a four twisted-pair, Category 5 cable.

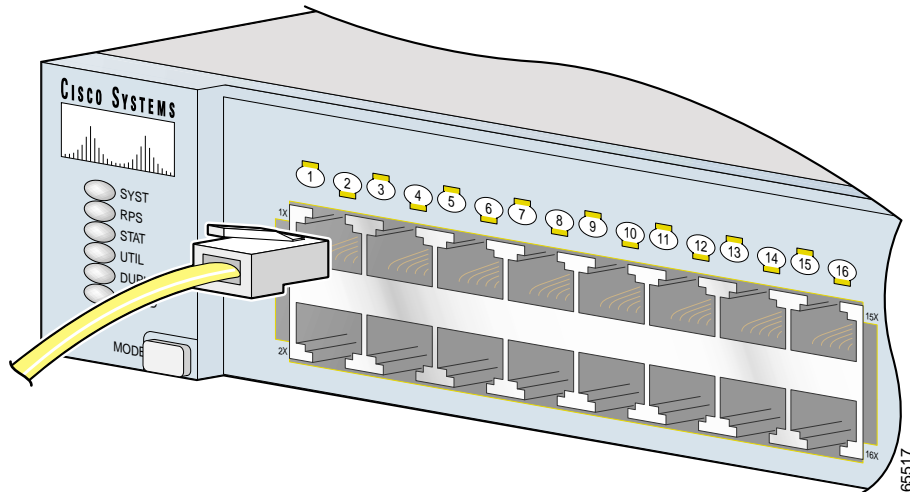
**Figure 3-31** Connecting to a Port on Catalyst 2950-12, 2950-24, 2950C-24, 2950SX-24, and 2950T-24 Switches



**Figure 3-32** Connecting to a Port on Catalyst 2950G-12-EI, 2950G-24-EI, and 2950G-24-EI-DC Switches



**Figure 3-33** Connecting to a Port on Catalyst 2950G-48-EI Switches



**Step 2** Insert the other cable end in an RJ-45 connector on the target device.

**Step 3** Observe the port status LED.

The LED turns green when the switch and the target device have an established link.

The LED turns amber while Spanning Tree Protocol (STP) discovers the network topology and searches for loops. This process takes about 30 seconds, and then the LED turns green.

If the LED is off, the target device might not be turned on, there might be a cable problem, or there might be a problem with the adapter installed in the target device. See [Chapter 4, “Troubleshooting,”](#) for solutions to cabling problems.

**Step 4** Reconfigure and restart the target device if necessary.

**Step 5** Repeat Steps 1 through 4 to connect each port.

## Connecting to 100BASE-FX and 1000BASE-SX Ports

The 100BASE-FX and 1000BASE-SX ports operate only in full-duplex mode.

You can connect a 100BASE-FX or 1000BASE-SX port to an SC or ST port on a target device by using one of the MT-RJ fiber-optic patch cables listed in [Table 3-1](#). Use the Cisco part numbers in [Table 3-1](#) to order the patch cables that you need.

**Table 3-1** MT-RJ Patch Cables for 100BASE-FX and 1000BASE-SX Connections

Type	Cisco Part Number
1-meter, MT-RJ-to-SC multimode cable	CAB-MTRJ-SC-MM-1M
3-meter, MT-RJ-to-SC multimode cable	CAB-MTRJ-SC-MM-3M
5-meter, MT-RJ-to-SC multimode cable	CAB-MTRJ-SC-MM-5M
1-meter, MT-RJ-to-ST multimode cable	CAB-MTRJ-ST-MM-1M
3-meter, MT-RJ-to-ST multimode cable	CAB-MTRJ-ST-MM-3M
5-meter, MT-RJ-to-ST multimode cable	CAB-MTRJ-ST-MM-5M

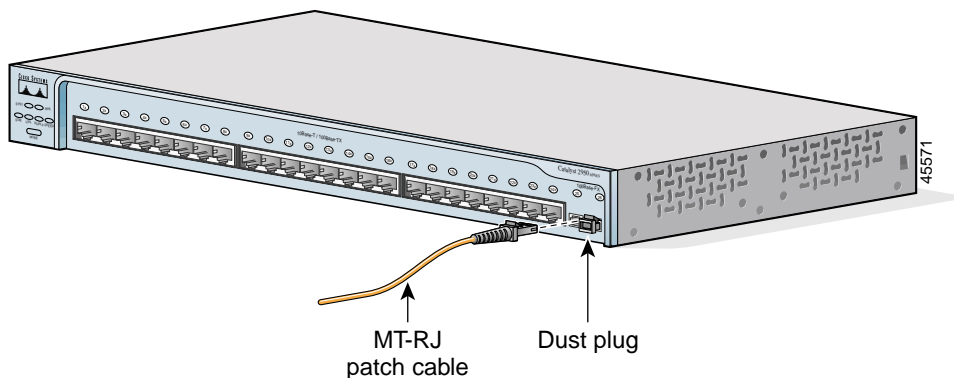
**Caution**

Do not remove the dust plugs from the fiber-optic ports or the rubber caps from the fiber-optic cable until you are ready to connect the cable. The plugs and caps protect the fiber-optic ports and cables from contamination and ambient light.

Follow these steps to connect the switch to a 100BASE-FX or 1000BASE-SX device:

- Step 1** Remove the dust plugs from the 100BASE-FX or 1000BASE-SX port and the rubber caps from the MT-RJ patch cable. Store them for future use.
- Step 2** Insert the cable in a 100BASE-FX or 1000BASE-SX port. (See [Figure 3-34](#).)

**Figure 3-34** Connecting to a 100BASE-FX or 1000BASE-SX Port



- Step 3** Insert the other cable end in an SC or ST port on the target device.
- Step 4** Observe the port status LED.

The LED turns green when the switch and the target device have an established link.

The LED turns amber while STP discovers the network topology and searches for loops. This process takes about 30 seconds, and then the port LED turns green.

If the LED is off, the target device might not be turned on, there might be a cable problem, or there might be a problem with the adapter installed in the target device. See [Chapter 4, “Troubleshooting,”](#) for solutions to cabling problems.

- Step 5** Reconfigure and restart the target device if necessary.
- Step 6** Repeat Steps 1 through 5 to connect each port.
- 

## Connecting to an LRE Port

Depending on the switch model, you can connect the LRE port to up to 8 or up to 24 LRE customer premises equipment (CPE) devices through a patch panel. For information about which LRE CPE devices are supported by the LRE switches, see [Table 2-1 on page 2-4](#).



### Note

---

You can connect both Cisco 575 LRE CPE and Cisco 585 LRE CPE devices to your Catalyst 2950ST-8 LRE or Catalyst 2950ST-24 LRE switch.

You can connect only the Cisco 576 LRE CPE 997 device to LRE ports on a Catalyst 2950ST-24 LRE 997 switch.

You can hot swap the CPE devices without powering down the switch or disrupting the other switch ports.

---

## Connection Guidelines

If telephone services, such as voice or Integrated Services Digital Network (ISDN), use the same cabling as the LRE traffic, you must connect the LRE to a plain old telephone service (POTS) splitter. The splitter routes LRE data (high-frequency) and voice (low-frequency) traffic from the telephone line to the switch and private branch exchange (PBX) switch or public switched telephone network (PSTN).

If the other telephone services are connected through a PBX switch, you can use a Cisco LRE 48 POTS Splitter. The PBX routes voice traffic to private telephone networks and the PSTN. For more information about the Cisco LRE 48 POTS Splitter (PS-1M-LRE-48), refer to the *Installation and Warranty Notes for the Cisco LRE 48 POTS Splitter*.

If the installation does not have a PBX, you need to use a homologated POTS splitter to connect to the PSTN. For more information about homologated POTS splitters, contact your Cisco sales representative.

If a connection to a telephone network is not required, you do not need a splitter, and you can connect the switch to the patch panel.

## Limitations and Restrictions with POTS Splitters

These limitations and restrictions apply when you use a POTS splitter with Catalyst 2950 LRE switches and Cisco LRE CPE devices:

- The Catalyst 2950ST-8 LRE switch, Catalyst 2950ST-24 LRE switch, Cisco 575 LRE CPE, and Cisco 585 LRE CPE are designed to share lines with analog, ISDN, and digital PBX switch telephones that use the 0 to 700 kHz frequency range.

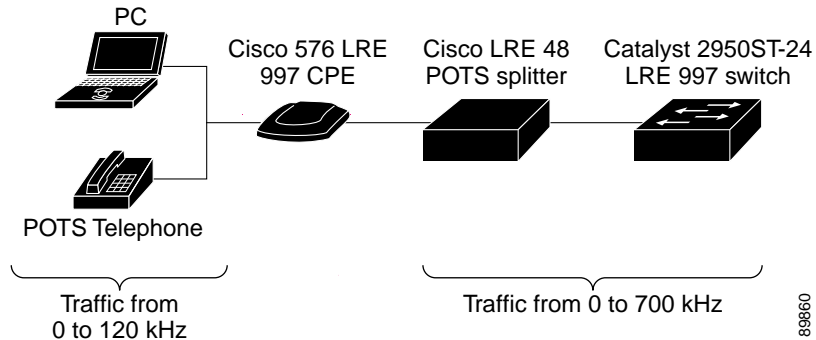
Digital telephones connected to digital PBX switches that use frequencies above 700 kHz do not work when sharing a line with LRE signals. Due to the proprietary nature of digital PBX switches, some digital PBX switch services use frequencies above 700 kHz.

- You can use a Cisco LRE 48 POTS Splitter with a Catalyst 2950ST-8 LRE switch, Catalyst 2950ST-24 LRE switch, Cisco 575 LRE CPE, and Cisco 585 LRE CPE. For installation instructions, refer to the *Installation and Warranty Notes for the Cisco LRE 48 POTS Splitter*.
- The Catalyst 2950ST-24 LRE 997 switch and Cisco 576 LRE 997 CPE are designed to share lines with analog and ISDN telephones that use the 0 to 120 kHz frequency range.
- We recommend that *you do not use* a Cisco LRE 48 POTS Splitter with a Catalyst 2950ST-24 LRE 997 switch and a Cisco 576 LRE 997 CPE as shown in [Figure 3-35](#). Only traffic in a specific frequency range can be sent to and from the devices attached to the CPE.

In [Figure 3-35](#), only traffic from 0 to 120 kHz can pass from a device attached to the CPE, such as a computer or telephone, to the CPE, a splitter, and a switch. In the reverse direction, traffic from 0 to 700 kHz can pass through the switch and splitter to the CPE, but only traffic from 0 to 120 kHz can pass through the CPE to a computer or a telephone.

For more information, refer to the *Installation and Warranty Notes for the Cisco LRE 48 POTS Splitter*.

**Figure 3-35** *Limitations Using a Cisco LRE 48 POTS Splitter with a Catalyst 2950ST-24 LRE 997 Switch and a Cisco 576 LRE 997 CPE*



## Required Cables

Connecting the LRE port to a patch panel or a POTS splitter requires a male-to-male RJ-21 cable, Category 5 or above. You can order RJ-21 cables from your cable vendor, or you can order these cables from your Cisco sales representative:

- CAB-5-M120M120-5= (Category 5 cable with 90-degree, male-to-male RJ-21 connectors)
- CAB-5-M180M120-5= (Category 5 cable with 120-degree, male-to-male RJ-21 connectors)

The screws that you need to secure the cable to the switch are shipped with the cable. Contact your Cisco sales representative for more information.



## Connecting to a Patch Panel or POTS Splitter

To connect the LRE port to a patch panel or POTS splitter, follow these steps:

---

**Step 1** Connect one end of a cable connected to the wiring trunk to the RJ-21 connector (the LRE port) on the switch. (See [Figure 3-36](#) and [Figure 3-37](#).)

**Step 2** Referring to [Figure 3-36](#) and [Figure 3-37](#), secure the cable to the switch:

- For a 90-degree connector, see the top of [Figure 3-36](#) and [Figure 3-37](#).
- For a 12-degree connector, see the bottom of [Figure 3-36](#) and [Figure 3-37](#).



---

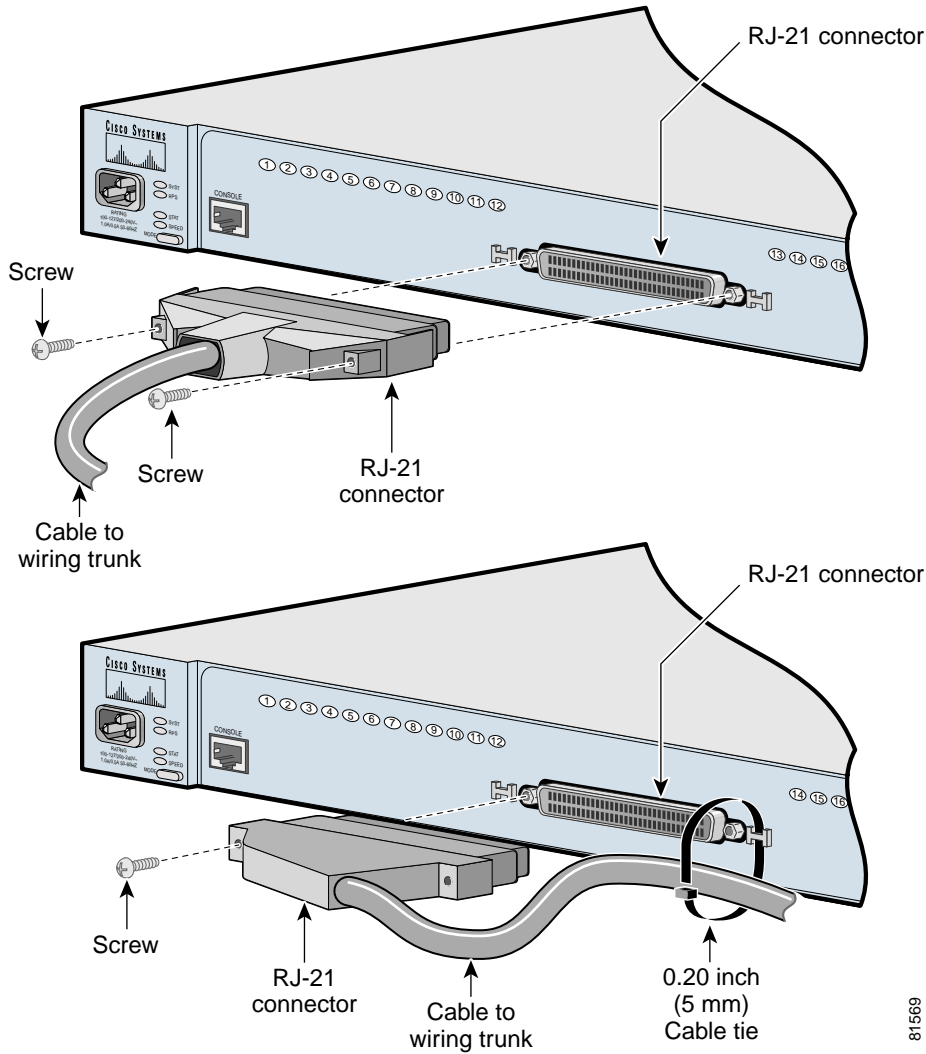
**Note** The cable tie is not included with the connector and cable assembly.

---

**Step 3** Connect the other end of the cable to the patch panel or POTS splitter.

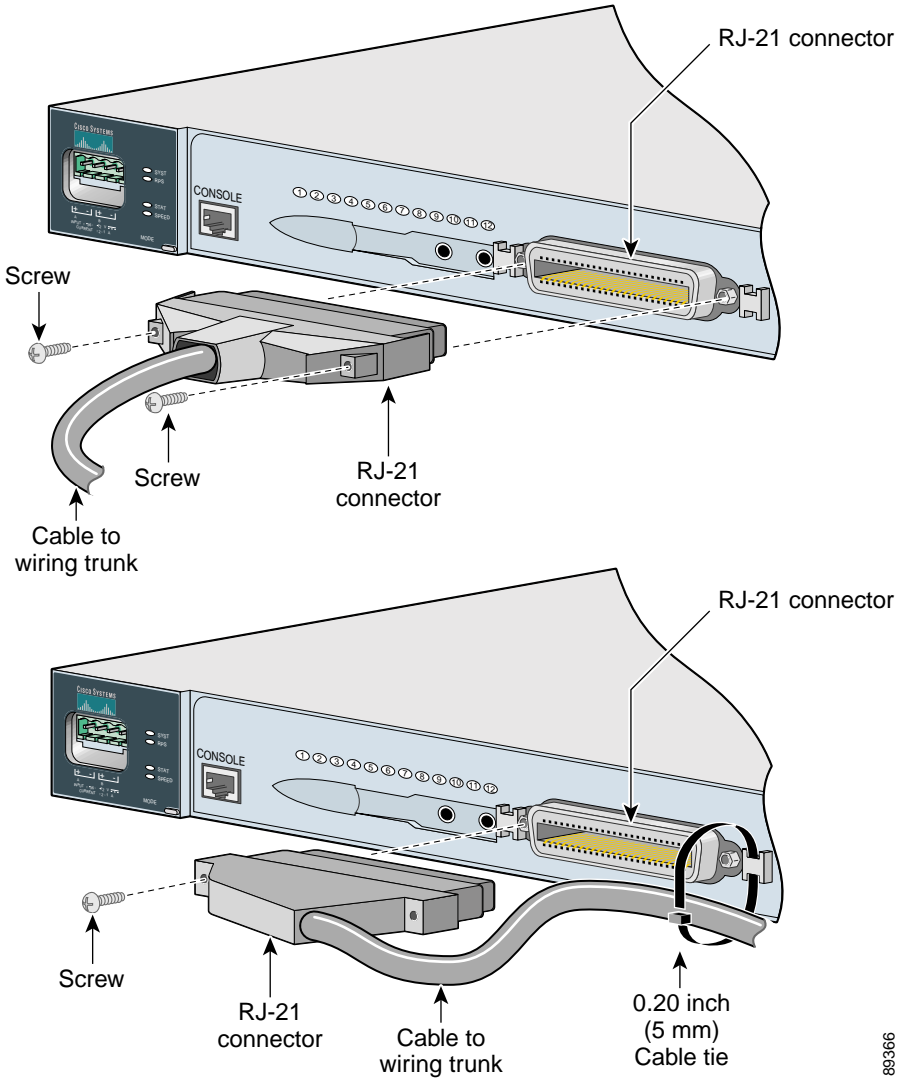
---

Figure 3-36 Connecting to an LRE Port on a Catalyst 2950ST-8 LRE or 2950ST-24 LRE Switch



81569

Figure 3-37 Connecting to an LRE Port on a Catalyst 2950ST-24 LRE 997 Switch



89366

Each LRE port status LED turns on when it establishes a link with a Cisco LRE CPE device. For more information about the LRE link between the switch LRE port and the CPE and about the configuration and management of CPE devices, refer to the switch software configuration guide.

For more information about the Cisco LRE CPE devices, refer to the *Cisco LRE CPE Hardware Installation Guide*.

## Connecting to GBIC Module Ports

These sections describe how to connect to a GBIC module port.

- [Connecting to 1000BASE-X GBIC Module Ports, page 3-45](#)
- [Connecting to 1000BASE-T GBIC Module Ports, page 3-47](#)
- [Connecting to GigaStack GBIC Module Ports, page 3-48](#)

For instructions about how to connect to the CWDM GBIC module ports, refer to the documentation that came with that GBIC module.

For detailed instructions about installing, removing, and connecting to the GBIC module (the 1000BASE-X module, the 1000BASE-T module, the CWDM GBIC module, or the GigaStack module), refer to the GBIC module documentation.

When connecting the ports on the Catalyst 2950G-24-EI-DC and Catalyst 2950ST-24 LRE 997 switches to other devices, follow these guidelines:

**Caution**

To comply with the intrabuilding lightning surge requirements, intrabuilding wiring must be shielded, and the shield for the wiring must be grounded at both ends.

**Caution**

The Catalyst 2950G-24-EI-DC or Catalyst 2950ST-24 LRE 997 switch is suitable only for intrabuilding or nonexposed wiring connections.

## Connecting to 1000BASE-X GBIC Module Ports

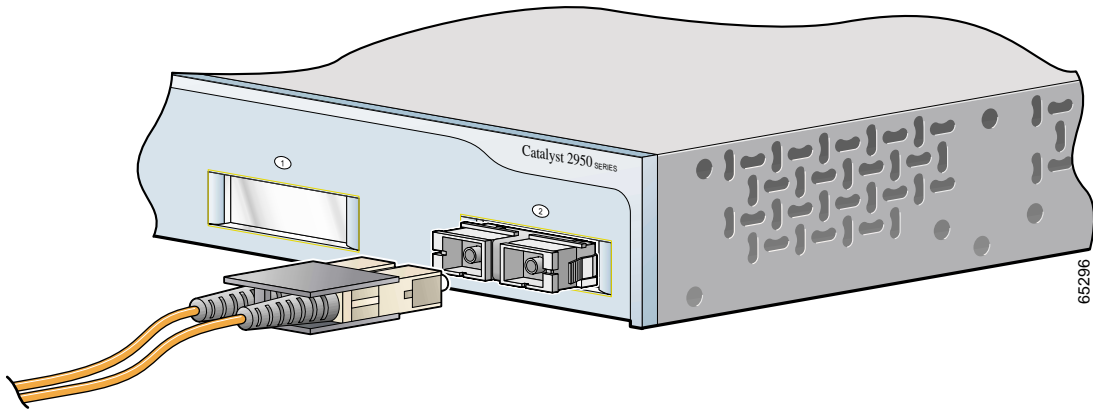
**Caution**

Do not remove the rubber plugs from the GBIC module port or the rubber caps from the fiber-optic cable until you are ready to connect the cable. The plugs and caps protect the GBIC module ports and cables from contamination and ambient light.

After installing the 1000BASE-X GBIC in the GBIC module slot, follow these steps:

- Step 1** Remove the rubber plugs from the GBIC module port, and store them for future use.
- Step 2** Insert the SC connector in the fiber-optic receptacle (see [Figure 3-38](#)).

Figure 3-38 Connecting to a 1000 BASE-X GBIC Port



**Step 3** Insert the other cable end in a fiber-optic receptacle on a target device.

**Step 4** Observe the port status LED.

The LED turns green when the switch and the target device have an established link.

The LED turns amber while STP discovers the network topology and searches for loops. This process takes about 30 seconds, and then the port LED turns green.

If the LED is off, the target device might not be turned on, there might be a cable problem, or there might be problem with the adapter installed in the target device. See [Chapter 3, “Troubleshooting,”](#) for solutions to cabling problems.

**Step 5** Reconfigure and restart the switch or target device if necessary.

---

## Connecting to 1000BASE-T GBIC Module Ports

After installing the 1000BASE-T GBIC in the GBIC module slot, follow these steps:

**Caution**

To prevent ESD damage, follow your normal board and component handling procedures.

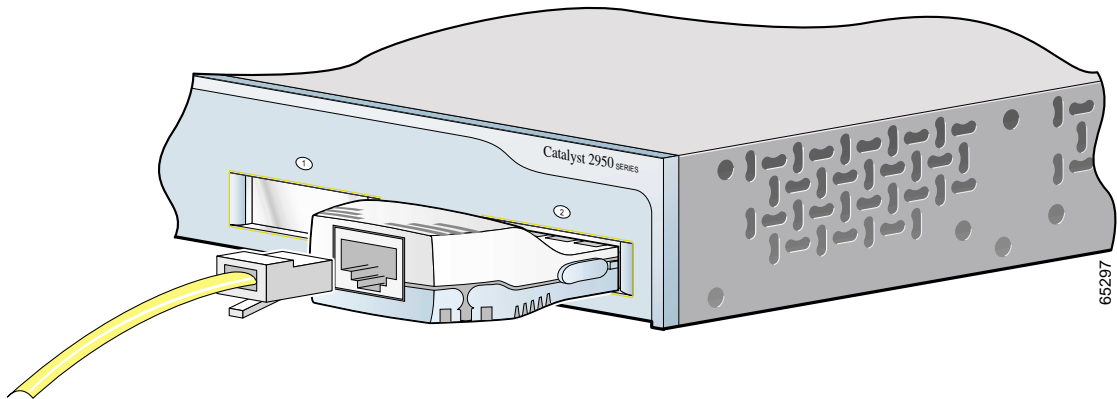
**Step 1**

When connecting to servers, workstations, and routers, insert a four twisted-pair, straight-through cable in the RJ-45 connector. When connecting to switches or repeaters, insert a four twisted-pair, crossover cable (see [Figure 3-39](#)).

**Note**

When connecting to a 1000BASE-T device, be sure to use a four twisted-pair, Category 5 cable.

*Figure 3-39 Connecting to a 1000BASE-T GBIC Port*



**Step 2** Insert the other cable end in an RJ-45 connector on a target device.

**Step 3** Observe the port status LED.

The LED turns green when the switch and the target device have an established link.

The LED turns amber while STP discovers the network topology and searches for loops. This process takes about 30 seconds, and then the LED turns green.

If the LED is off, the target device might not be turned on, there might be a cable problem, or there might be a problem with the adapter installed in the target device. See [Chapter 3, “Troubleshooting,”](#) for solutions to cabling problems.

**Step 4** Reconfigure and restart the switch or target device, if necessary.

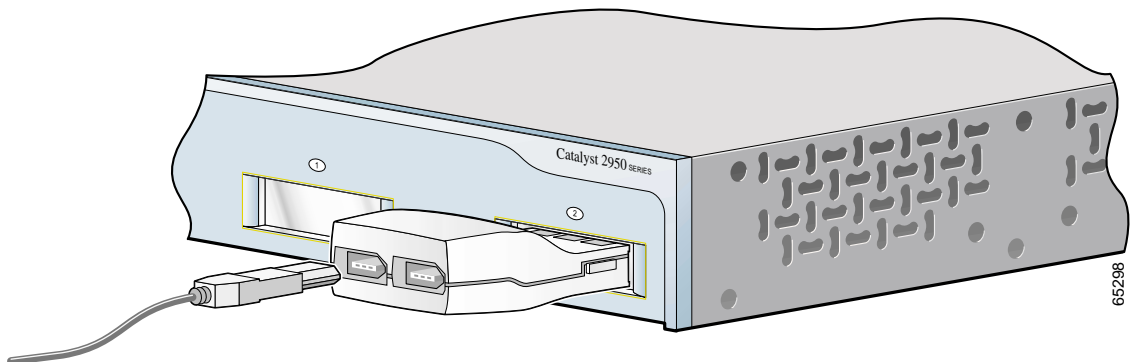
---

## Connecting to GigaStack GBIC Module Ports

After installing the GigaStack GBIC in the GBIC module slot, follow these steps:

**Step 1** Insert the GigaStack cable connector in the GBIC (see [Figure 3-40](#)).

*Figure 3-40 Connecting to a GigaStack GBIC Port*





**Step 2** Insert the other cable end in a port on a target device.

**Step 3** Observe the port status LED.

The LED turns green when the switch and the target device have an established link.

The LED turns amber while STP discovers the network topology and searches for loops. This process takes about 30 seconds, and then the port LED turns green.

If the LED is off, the target device might not be turned on, there might be a cable problem, or there might be a problem with the adapter installed in the target device. See [Chapter 4, “Troubleshooting,”](#) for solutions to cabling problems.

**Step 4** Reconfigure and restart the switch or target device, if necessary.

---

## Connecting to an SFP Module

This section describes how to connect to an SFP module. For instructions about how to install or remove an SFP module, see the [“Installing and Removing SFP Modules”](#) section on page 3-28.



### Caution

Do not remove the rubber plugs from the SFP module port or the rubber caps from the fiber-optic cable until you are ready to connect the cable. The plugs and caps protect the SFP module ports and cables from contamination and ambient light.

Before connecting to an SFP module, be sure that you understand the port and cabling stipulations in [Table 2-2 on page 2-16](#) and in the [“SFP Module Slots”](#) section on page 2-14. See [Appendix B, “Connectors and Cables,”](#) for information about the LC on the SFP module.



### Note

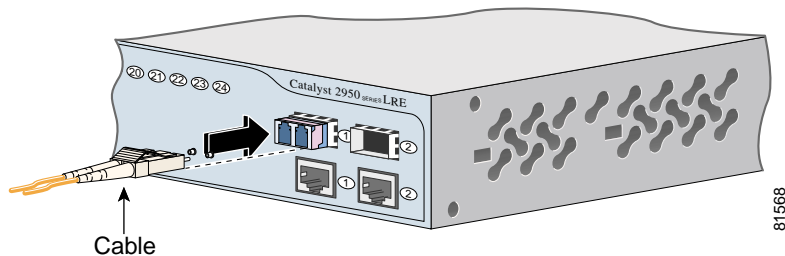
Refer to the Catalyst 2950 LRE release notes for the list of supported SFP modules.

---

Follow these steps to connect a fiber-optic cable to an SFP module:

- 
- Step 1** Remove the rubber plugs from the module port and fiber-optic cable, and store them for future use.
- Step 2** Insert one end of the fiber-optic cable into the SFP module port (see [Figure 3-41](#)).

**Figure 3-41** Connecting to an SFP Module Port



- Step 3** Insert the other cable end in a fiber-optic receptacle on a target device.
- Step 4** Observe the port status LED.

The LED turns green when the switch and the target device have an established link.

The LED turns amber while the STP discovers the network topology and searches for loops. This process takes about 30 seconds, and then the port LED turns green.

If the LED is off, the target device might not be turned on, there might be a cable problem, or there might be problem with the adapter installed in the target device. See [Chapter 3, “Troubleshooting,”](#) for solutions to cabling problems.

- Step 5** If necessary, reconfigure and restart the switch or target device.
- 

## Where to Go Next

For information about starting up the switch, see [Chapter 1, “Quick Installation.”](#)

For information about configuring the switch, refer to the switch software configuration guide.



# Troubleshooting

---

The front-panel LEDs provide troubleshooting information about the switch. They show power-on self-test (POST) failures, port-connectivity problems, and overall switch performance. For a full description of the LEDs, see the [“LEDs” section on page 2-17](#).

You can also get statistics from the Cluster Management Suite (CMS), the command-line interface (CLI), the Cisco Intelligence Engine 2100 (IE2100) Series Configuration Registrar, or a Simple Network Management Protocol (SNMP) workstation. Refer to the switch software configuration guide, the switch command reference, or the documentation that came with your IE2100 or SNMP application for details.

This chapter provides these topics for troubleshooting problems:

- [Understanding POST Results, page 4-2](#)
- [Diagnosing Problems, page 4-2](#)

# Understanding POST Results

While the switch powers on, it automatically begins POST, a series of tests that verifies that the switch functions properly. When the switch begins POST, the system LED is off. If POST completes successfully, the LED turns green. If POST fails, the LED turns amber.

**Note**

---

POST failures are usually fatal. Call Cisco Systems if your switch does not pass POST.

---

## Diagnosing Problems

Common switch problems fall into these categories:

- Poor performance
- No connectivity
- Corrupted software

Table 4-1 describes how to detect and solve these problems.

**Table 4-1 Common Problems and Solutions**

Symptom	Possible Cause	Resolution
<b>Poor performance or excessive errors.</b>	Duplex autonegotiation mismatch.	Refer to the switch software configuration guide for information about identifying autonegotiation mismatches.
	<b>Cabling distance exceeded.</b> <ul style="list-style-type: none"> <li>• Port statistics show excessive FCS<sup>1</sup>, late-collision, or alignment errors.</li> <li>• For 10BASE-T, 100BASE-TX, and 1000BASE-T connections: <ul style="list-style-type: none"> <li>– The distance between the port and the attached device exceeds 328 feet (100 meters).</li> <li>– If the switch is attached to a repeater, the total distance between the two end stations exceeds the cabling guidelines.</li> </ul> </li> </ul>	<ul style="list-style-type: none"> <li>• Refer to the switch software configuration guide for information about displaying port statistics.</li> <li>• Reduce cable length to within the recommended distances.</li> <li>• Refer to your repeater documentation for cabling guidelines.</li> </ul>
	<ul style="list-style-type: none"> <li>• For GBIC<sup>2</sup> module port connections: The distance between the GBIC module port and the attached device exceeds the GBIC cabling guidelines.</li> </ul>	<ul style="list-style-type: none"> <li>• Refer to your GBIC module documentation for cabling guidelines.</li> </ul>
	<ul style="list-style-type: none"> <li>• For SFP<sup>3</sup> module port connections: The distance between the SFP module port and the attached device exceeds the SFP cabling guidelines.</li> </ul>	<ul style="list-style-type: none"> <li>• See <a href="#">Table 2-2 on page 2-16</a> for SFP cabling guidelines.</li> </ul>

Table 4-1 Common Problems and Solutions (continued)

Symptom	Possible Cause	Resolution
<b>Poor performance or excessive errors (continued).</b>	<b>Bad adapter in attached device.</b> <ul style="list-style-type: none"> <li>Excessive errors found in port statistics.</li> </ul>	<ul style="list-style-type: none"> <li>Run adapter card diagnostic utility.</li> </ul>
	<b>STP<sup>4</sup> checking for possible loops.</b>	Wait 30 seconds for port status LED to turn green.
<b>No connectivity.</b>	<b>Incorrect or bad cable.</b> No link at both ends. <ul style="list-style-type: none"> <li>A crossover cable was used when a straight-through was required, or the reverse.</li> <li>The cable is wired incorrectly.</li> <li>STP checking for possible loops.</li> </ul>	<ul style="list-style-type: none"> <li>For the correct pinouts and the proper application of crossover vs. straight-through cables, see the <a href="#">“Cable and Adapter Specifications”</a> section on page B-8.</li> <li>Replace it with a tested good cable.</li> <li>Wait 30 seconds for port status LED to turn green.</li> </ul>
	Switch not recognizing a GBIC module.	Refer to your GBIC module documentation for more information.
	Switch not recognizing an SFP module.	Refer to your SFP module documentation for more information.
<b>Unreadable characters on the management console.</b>	Incorrect baud rate.	Reset the terminal-emulation software to 9600 baud.
<b>System LED is amber, and all port LEDs are off.</b>	Corrupted software.	Attach a monitor to the serial port to display the switch boot loader. For more information, refer to the switch software configuration guide.

Table 4-1 Common Problems and Solutions (continued)

Symptom	Possible Cause	Resolution
<b>System LED is amber.</b>	<ul style="list-style-type: none"> <li>Internal fan fault detected.</li> <li>Nonfatal or fatal POST error detected.</li> </ul>	<ul style="list-style-type: none"> <li>Check if the fan has failed by using the <b>show env fan</b> privileged EXEC command. If the fan has failed, call Cisco Systems.</li> <li>Use the <b>show post</b> privileged EXEC command to see which POST test failed.</li> </ul>
<b>Switch placed in error-disabled state after CWDM<sup>5</sup> GBIC or SFP module is inserted.</b>	Bad or non-Cisco-approved CWDM GBIC module or SFP module.	<p>Remove the CWDM GBIC or SFP module from the switch, and replace it with a Cisco-approved module. Use the <b>errdisable recovery cause gbic-invalid</b> global configuration command to verify port status, and enter a time interval to recover from the error-disabled state.</p> <p>Refer to the switch software configuration guide for information about the <b>errdisable recovery</b> command.</p>

Table 4-1 Common Problems and Solutions (continued)

Symptom	Possible Cause	Resolution
<b>STAT LED on Catalyst 2950 LRE<sup>6</sup> switch is not turned on.</b>	Telephone cable is loose or is not connected properly.	Reseat telephone cable into the telephone wall jack and the Cisco LRE CPE <sup>7</sup> .
	Telephone cable is defective.	Replace the telephone cable.
	Cable trunking defective.	Repair the cable trunking, or select an alternative pair of cables.
	Cisco LRE CPE is not communicating with Catalyst 2950 LRE switch, or Cisco LRE CPE might be attempting to exceed the rate or the reach selected by the switch.	<ul style="list-style-type: none"> <li>Reduce cable length to within the recommended distances. (See the “<a href="#">LRE Port</a>” section on page 2-12 for LRE cabling guidelines.)</li> <li>Refer to the switch software configuration guide for information about verifying LRE port link status.</li> </ul>
	Catalyst 2950 LRE switch does not support the Cisco LRE CPE.	See the compatibility matrix, <a href="#">Table 2-1 on page 2-4</a> , for more information.

1. FCS = frame check sequence
2. GBIC = Gigabit Interface Converter
3. SFP = small form-factor pluggable
4. STP = Spanning Tree Protocol
5. CWDM = Coarse Wave Division Multiplexer
6. LRE = Long-Reach Ethernet
7. CPE = customer premises equipment





## Technical Specifications

---

[Table A-1](#) through [Table A-5](#) list the technical specifications for the Catalyst 2950 switches. [Table A-6](#) lists the technical specifications for fiber-optic uplink ports.

[Table A-7](#) lists the regulatory agency approvals for the switches other than the Catalyst 2950 Long-Reach Ethernet (LRE) switches. [Table A-8](#) and [Table A-9](#) list the regulatory agency approvals for the Catalyst 2950 LRE switches. [Table A-10](#) lists the regulatory agency approval only for the Catalyst 2950G-24-EI-DC switch.

**Table A-1** *Technical Specifications for Catalyst 2950-12, 2950-24, 2950C-24, 2950SX-24, and 2950T-24 Switches*

<b>Environmental Ranges</b>	
Operating temperature	32 to 113°F (0 to 45°C)
Storage temperature	-13 to 158°F (-25 to 70°C)
Operating humidity	10 to 85% (noncondensing)
Operating altitude	Up to 10,000 ft (3000 m)
Storage altitude	Up to 15,000 ft (4570 m)
Shock	84 in. per sec (2.13 m per sec) <sup>1</sup>
<b>Power Requirements</b>	
AC input voltage	100 to 127/200 to 240 VAC (autoranging) 50 to 60 Hz
DC input voltages for the Cisco RPS <sup>2</sup> 300 Redundant Power System	+12V --- @4.5A
DC input voltages for the Cisco RPS 675	+12V --- @4.5A
Power consumption	30W (maximum) 102 Btus per hour
Power rating	0.05 kVA
<b>Physical Dimensions</b>	
Weight	6.5 lb (3 kg)
Dimensions (H x W x D)	1.72 x 17.5 x 9.52 in. (4.36 x 44.45 x 24.18 cm)

1. This switch meets ASTM D3332.
2. RPS = redundant power system

Table A-2 Technical Specifications for Catalyst 2950G-12-EI, 2950G-24-EI, and 2950G-48-EI Switches

	Catalyst 2950G-12-EI and 2950G-24-EI Switches	Catalyst 2950G-48-EI Switch
<b>Environmental Ranges</b>		
Operating temperature	32 to 113°F (0 to 45°C)	32 to 113°F (0 to 45°C)
Storage temperature	-13 to 158°F (-25 to 70°C)	-13 to 158°F (-25 to 70°C)
Operating humidity	10 to 85% (noncondensing)	10 to 85% (noncondensing)
Operating altitude	Up to 10,000 ft (3000 m)	Up to 10,000 ft (3000 m)
Storage altitude	Up to 15,000 ft (4570 m)	Up to 15,000 ft (4570 m)
Shock	84 in. per sec (2.13 m per sec) <sup>1</sup>	84 in. per sec (2.13 m per sec)
<b>Power Requirements</b>		
AC input voltage	100 to 127/200 to 240 VAC (autoranging) 50 to 60 Hz	100 to 127/200 to 240 VAC (autoranging) 50 to 60 Hz
DC input voltage for the Cisco RPS <sup>2</sup> 300	+12V <sup>---</sup> @4.5A	+12V <sup>---</sup> @4.5A
DC input voltage for the Cisco RPS 675	+12V <sup>---</sup> @4.5A	+12V <sup>---</sup> @4.5A
Power consumption	30W (maximum) 102 Btus per hour	45W (maximum) 154 Btus per hour
Power rating	0.05 kVA	0.075 kVA
<b>Physical Dimensions</b>		
Weight	6.5 lb (3 kg)	10.5 lb (4.8 kg)
Dimensions (H x W x D)	1.72 x 17.5 x 9.52 in. (4.36 x 44.45 x 24.18 cm)	1.72 x 17.5 x 13 in. (4.36 x 44.45 x 33.02 cm)

1. This switch meets ASTM D3332.

2. RPS = redundant power system

**Table A-3 Technical Specifications for Catalyst 2950G-24-EI-DC Switch**

<b>Environmental Ranges</b>	
Operating temperature	32 to 113°F (0 to 45°C)
Storage temperature	-13 to 158°F (-25 to 70°C)
Operating humidity	10 to 85% (noncondensing)
Operating altitude	Up to 10,000 ft (3000 m)
Storage altitude	Up to 15,000 ft (4570 m)
Shock	84 in. per sec (2.13 m per sec) <sup>1</sup>
<b>Power Requirements</b>	
Power consumption	30W (102 Btus per hour)
Power rating	0.05 kVA
DC input voltage	-36 to -72 VDC
Wire gauge for power connection	18 AWG <sup>2</sup> (6 AWG for protective earth)
Branch circuit protection	5A
<b>Physical Dimensions</b>	
Weight	6.5 lb (3 kg)
Dimensions (H x W x D)	1.72 x 17.5 x 9.52 in. (4.36 x 44.45 x 24.18 cm)

1. This switch meets ASTM D3332.
2. AWG = American Wire Gauge

**Table A-4 Technical Specifications for Catalyst 2950ST-8 LRE and Catalyst-2950ST-24 LRE Switches**

<b>Environmental Ranges</b>	
Operating temperature	32 to 113°F (0 to 45°C)
Storage temperature	-13 to 158°F (-25 to 70°C)
Operating humidity	10 to 85% (noncondensing)
Operating altitude	Up to 10,000 ft (3000 m)
Storage altitude	Up to 15,000 ft (4570 m)
Shock	84 in. per sec (2.13 m per sec) <sup>1</sup>
<b>Power Requirements</b>	
AC input voltage	100 to 127/200 to 240 VAC (autoranging) 50 to 60 Hz
DC input voltage for the Cisco RPS <sup>2</sup> 300	+12V ---@4A
DC input voltage for the Cisco RPS 675	+12V ---@4A
Power consumption	50W (maximum) 171 Btus per hour
Power rating	0.083 kVA
Branch circuit protection	5A
<b>Physical Dimensions</b>	
Weight	8 lb (3.6 kg)
Dimensions (H x W x D)	1.73 x 17.5 x 9.96 in. (4.36 x 44.45 x 24.18 cm)

1. This switch meets ASTM D3332.
2. RPS = redundant power system

**Table A-5** Technical Specifications for Catalyst-2950ST-24 997 LRE Switches

<b>Environmental Ranges</b>	
Operating temperature	32 to 113°F (0 to 45°C)
Storage temperature	-13 to 158°F (-25 to 70°C)
Operating humidity	10 to 85% (noncondensing)
Operating altitude	Up to 10,000 ft (3000 m)
Storage altitude	Up to 15,000 ft (4570 m)
Shock	84 in. per sec (2.13 m per sec) <sup>1</sup>
<b>Power Requirements</b>	
Power consumption	50W (maximum) 171 Btus per hour
Power rating	0.083 kVA
DC input voltage	-36 to -72 VDC
Wire gauge for power connection	18 AWG <sup>2</sup> (6 AWG for protective earth)
Branch circuit protection	5A
<b>Physical Dimensions</b>	
Weight	8 lb (3.6 kg)
Dimensions (H x W x D)	1.73 x 17.5 x 9.96 in. (4.36 x 44.45 x 24.18 cm)

1. This switch meets ASTM D3332.
2. AWG = American Wire Gauge

**Table A-6 Fiber-Optic Port Specifications for Catalyst 2950C-24, Catalyst 2950SX-24, and Catalyst 2950 LRE Switches**

Fiber-Port Power Levels	Catalyst 2950C-24	Catalyst 2950SX-24	Catalyst 2950ST-8 LRE, 2950ST-24 LRE, and 2950ST-24 LRE 997
Optical transmitter wavelength	1300 nm <sup>1</sup>	850 nm	The transmitter wavelengths, receiver sensitivities, and transmitter power levels are SFP <sup>2</sup> -module dependent. For this information, refer to the technical specifications that came with your SFP module.
Optical receiver sensitivity for 50/125-micron cabling	-33.5 to -11.8 dBm <sup>3</sup>	-13.5 dBm	
Optical receiver sensitivity for 62.5/125-micron cabling	-33.5 to -11.8 dBm	-12.5 dBm	
Optical transmitter power for 50/125-micron cabling	-23.5 to -14 dBm	-9.5 to -4 dBm	
Optical transmitter power for 62.5/125-micron cabling	-20 to -14 dBm	-9.5 to -4 dBm	

1. nm = nanometers
2. SFP = small form-factor pluggable
3. dBm = decibel milliwatt

**Table A-7 Catalyst 2950 Switch Agency Approvals**

Safety	EMC
UL/CSA 60950	FCC Part 15 Class A
IEC 60950/EN 60950	EN 55022: 1998 (CISPR22) Class A
AS/NZS 3260, TS001	EN 55024: 1998 (CISPR24)
CE	VCCI Class A
	AS/NZS 3548 Class A
	CE
	CNS 13438 Class A
	MIC

**Table A-8 Catalyst 2950ST-8 LRE and 2950ST-24 LRE Switch Agency Approvals**

Safety	EMC
UL/CSA 60950, 3rd edition	USA CFR47, FCC, Part 15, Class A
IEC 60950 with Amendments A1 through A4 and A11	ICES-003, Class A
AS/NZS 3260 with Amendments A1 through A4	EN55022/CISPR22, Class A, 1998
TUV-GS to EN60950 with Amendments A1 through A4 and A11	EN 55024: ITE Immunity Standard. (CE Mark), 1998
CE	EN61000-4-2/IEC1000-4-2: Immunity to ESD
	EN61000-4-3/IEC1000-4-3: Immunity to Radio Frequency Electromagnetic Fields
	EN61000-4-4/IEC1000-4-4: Immunity to Electrical Fast Transients
	EN61000-4-5/IEC1000-4-5: Immunity to Power Line Transients (Surges)
	EN61000-4-6/IEC1000-4-6: Immunity to Radio Frequency Induced Conducted Disturbances
	EN61000-4-11/IEC1000-4-11: Immunity to Voltage Dips, Voltage Variations, and Short Voltage Interruptions
	AS/NZS 3548, Class A
	BSMI, Class A
	VCCI, Class A
MIC Mark	



**Table A-9 Catalyst 2950ST-24 LRE 997 Switch Agency Approvals**

<b>Safety</b>	<b>EMC</b>
UL/CSA 60950, 3rd edition	USA CFR47, FCC, Part 15, Class A
IEC 60950 with Amendments A1 through A4 and A11	ICES-003, Class A
AS/NZS 3260 with Amendments A1 through A4	EN55022/CISPR22, Class A, 1998
TUV-GS to EN60950 with Amendments A1 through A4 and A11	EN 55024: ITE Immunity Standard. (CE Mark), 1998
CE	EN61000-4-2/IEC1000-4-2: Immunity to ESD
	EN61000-4-3/IEC1000-4-3: Immunity to Radio Frequency Electromagnetic Fields
	EN61000-4-4/IEC1000-4-4: Immunity to Electrical Fast Transients
	EN61000-4-5/IEC1000-4-5: Immunity to Power Line Transients (Surges)
	EN61000-4-6/IEC1000-4-6: Immunity to Radio Frequency Induced Conducted Disturbances
	EN61000-4-11/IEC1000-4-11: Immunity to Voltage Dips, Voltage Variations, and Short Voltage Interruptions

**Table A-10 Catalyst 2950G-24-EI-DC Switch Agency Approvals**

<b>NEBS</b>
Bellcore GR-1089-CORE
Bellcore GR-63-CORE
Bellcore SR-3580 Level 3





## Connectors and Cables

---

This appendix describes the connectors, cables, and adapters that you use to connect the switch to other devices.

### Connector Specifications

These sections describe the connectors used with the Catalyst 2950 switches and contains this information:

- [10/100 Ports, page B-2](#)
- [10/100/1000 Ports, page B-3](#)
- [100BASE-FX and 1000BASE-SX Ports, page B-6](#)
- [LRE Port, page B-5](#)
- [GigaStack GBIC Module Ports, page B-7](#)
- [SFP Module Ports, page B-7](#)
- [Console Port, page B-8](#)

## 10/100 Ports

The 10/100 Ethernet ports use standard RJ-45 connectors and Ethernet pinouts with internal crossovers, as shown by an **X** in the port name. These ports have the transmit (TD) and receive (RD) signals internally crossed so that a twisted-pair straight-through cable and adapter can be attached to the port. [Figure B-1](#) shows the pinout.

When connecting 10/100 ports to other devices, such as servers, workstations, and routers, you can use a two or four twisted-pair, straight-through cable wired for 10BASE-T and 100BASE-TX. [Figure B-8](#) shows the two twisted-pair, straight-through cable schematics. [Figure B-10](#) shows the four twisted-pair, straight-through cable schematics.

When connecting the ports to other devices, such as switches or repeaters, you can use a two or four twisted-pair, crossover cable. [Figure B-9](#) shows the two twisted-pair, crossover cable schematics. [Figure B-11](#) shows the four twisted-pair, crossover cable schematics.

You can use Category 3, 4, or 5 cabling when connecting to 10BASE-T devices. You must use Category 5 cabling when connecting to 100BASE-TX devices.



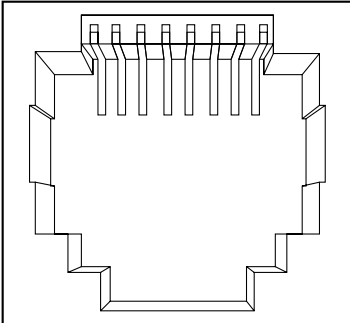
---

**Note**

Use a straight-through cable to connect two ports only when one port is designated with an **X**. Use a crossover cable to connect two ports when both ports are designated with an **X** or when both ports do not have an **X**.

---

**Figure B-1** 10/100 RJ-45 Pinouts

Pin	Label	1 2 3 4 5 6 7 8
1	RD+	
2	RD-	
3	TD+	
4	NC	
5	NC	
6	TD-	
7	NC	
8	NC	

H6318

## 10/100/1000 Ports

The 10/100/1000 Ethernet ports on Catalyst 2950T-24 and Catalyst 2950 Long-Reach Ethernet (LRE) switches use standard RJ-45 connectors. [Figure B-2](#) shows the pinout.



### Note

On the Catalyst 2950 LRE switches, the four input uplink ports are bundled as two logical ports, each consisting of a copper 10/100/1000 port and a fiber-optic small form-factor pluggable (SFP) module slot, respectively.

Within each logical port, you can use only the copper or the fiber-optic port at one time. If the Catalyst 2950 LRE switch senses more than two connections for both logical ports, the switch chooses the fiber-optic connections over the copper connections in default operation.

See the “[SFP Module Slots](#)” section on page 2-14 for more information on LRE uplink logical ports.

## Connecting to 10BASE-T and 100BASE-TX Devices

When connecting the ports to 10BASE-T and 100BASE-TX devices, such as servers, workstations, and routers, you can use a two or four twisted-pair, straight-through cable wired for 10BASE-T and 100BASE-TX. [Figure B-8](#) shows the two twisted-pair, straight-through cable schematics. [Figure B-10](#) shows the four twisted-pair, straight-through cable schematics.

When connecting the ports to 10BASE-T- and 100BASE-TX devices, such as switches or repeaters, you can use a two or four twisted-pair, crossover cable. [Figure B-9](#) shows the two twisted-pair, crossover cable schematics. [Figure B-11](#) shows the four twisted-pair, crossover cable schematics.

You can use Category 3, 4, or 5 cabling when connecting to 10BASE-T devices. You must use Category 5 cabling when connecting to 100BASE-TX devices.

## Connecting to 1000BASE-T Devices

When connecting the ports to 1000BASE-T devices, such as servers, workstations, and routers, you must use a four twisted-pair, Category 5, straight-through cable wired for 10BASE-T, 100BASE-TX, and 1000BASE-T. [Figure B-12](#) shows the straight-through cable schematics.

When connecting the ports to other devices, such as switches or repeaters, you must use a four twisted-pair, Category 5, crossover cable. [Figure B-13](#) shows the crossover cable schematics.



---

**Note**

Be sure to use a four twisted-pair, Category 5 cable when connecting to a 1000BASE-T device.

---



---

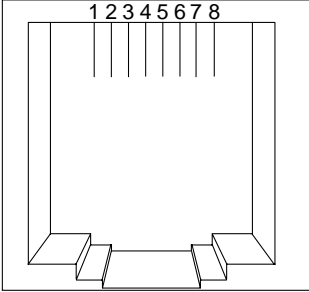
**Note**

Use a straight-through cable to connect two ports only when one port is designated with an **X**. Use a crossover cable to connect two ports when both ports are designated with an **X** or when both ports do not have an **X**.

---

**Figure B-2 RJ-45 Pinouts for 10/100/1000 and 1000BASE-T GBIC Module Ports**

Pin	Label
1	TP0+
2	TP0-
3	TP1+
4	TP2+
5	TP2-
6	TP1-
7	TP3+
8	TP3-

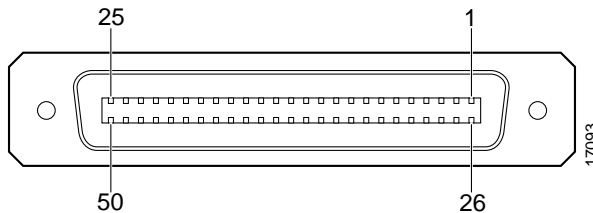


34751

## LRE Port

The LRE port uses a single 50-pin RJ-21 connector, as shown in [Figure B-3](#). Each LRE port uses two pins. Because the Catalyst 2950ST-24 LRE and Catalyst 2950ST-24 LRE 997 switches use 48 pins, pin 25 on the top row and pin 50 on the bottom row are not used.

The Catalyst 2950ST-8 LRE switch uses only 16 pins. Pins 9 through 25 on the top row and pins 34 through 50 on the bottom row are not used.

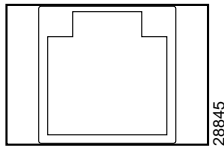
**Figure B-3 RJ-21 Connector**

## 100BASE-FX and 1000BASE-SX Ports

The 100BASE-FX and 1000BASE-SX ports use MT-RJ connectors, shown in [Figure B-4](#). These ports use 50/125- or 62.5/125-micron multimode fiber-optic cabling.

You can connect a 100BASE-FX or 1000BASE-SX port to an SC or ST port on a target device by using one of the MT-RJ fiber-optic patch cables listed in [Table 3-1 on page 3-36](#). Use the Cisco part numbers in [Table 3-1](#) to order the patch cables that you need.

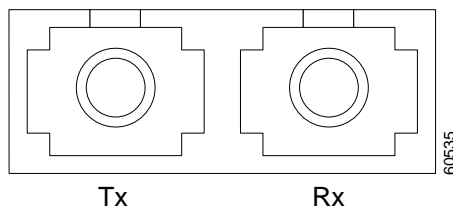
**Figure B-4** MT-RJ Connector



## 1000BASE-X GBIC Module Ports

1000BASE-X Gigabit Interface Converter (GBIC) module ports use duplex SC connectors, as shown in [Figure B-5](#).

**Figure B-5** 1000BASE-X SC Connector





## 1000BASE-T GBIC Module Ports

The 1000BASE-T GBIC module port uses one RJ-45 connector, as shown in [Figure B-2](#).

## GigaStack GBIC Module Ports

The GigaStack GBIC module ports use proprietary connectors, as shown in [Figure B-6](#). The GigaStack GBIC cables are proprietary, high-data-rate cables with enhanced signal integrity and EMI protection.



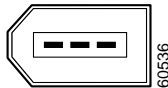
Caution

---

Do not use standard IEEE 1394 cables with the GigaStack GBIC.

---

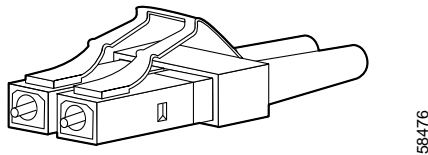
*Figure B-6 GigaStack Connector*



## SFP Module Ports

The Catalyst 2950 LRE switch uses SFP modules for fiber-optic uplink ports. Refer to the Catalyst 2950 LRE switch release notes for a list of supported SFP modules.

*Figure B-7 SFP Module Connector*



Warning

---

Invisible laser radiation may be emitted from disconnected fibers or connectors. Do not stare into beams or view directly with optical instruments.

---

## Console Port

The console port uses an 8-pin RJ-45 connector. You can connect a switch to a PC through the console port and the supplied RJ-45-to-DB-9 adapter cable. If you want to connect a switch to a terminal, you need to provide an RJ-45-to-DB-25 female DTE adapter. You can order a kit (part number ACS-DSBUASYN=) with that adapter from Cisco. For console-port and adapter-pinout information, see [Table B-3](#) and [Table B-4](#).

## Cable and Adapter Specifications

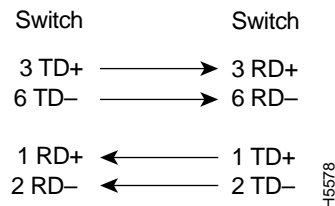
These sections describe the cables and adapters used with Catalyst 2950 switches.

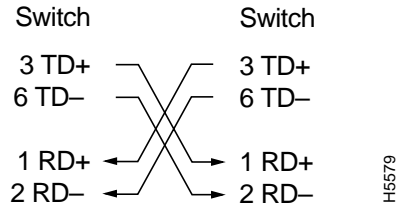
- [Two Twisted-Pair Cable Pinouts](#), page B-8
- [Four Twisted-Pair Cable Pinouts for 10/100 Ports](#), page B-9
- [Four Twisted-Pair Cable Pinouts for 1000BASE-T Ports](#), page B-10
- [RJ-21 Cable Pinouts](#), page B-11
- [Rollover Cable and Adapter Pinouts](#), page B-14

## Two Twisted-Pair Cable Pinouts

[Figure B-8](#) and [Figure B-9](#) show the schematics of two twisted-pair cables for 10/100 ports.

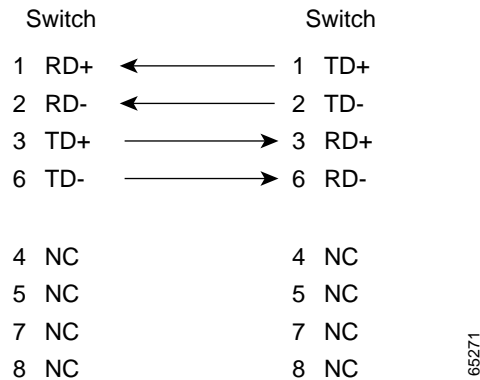
**Figure B-8** *Two Twisted-Pair Straight-Through Cable Schematic for 10/100 Ports*

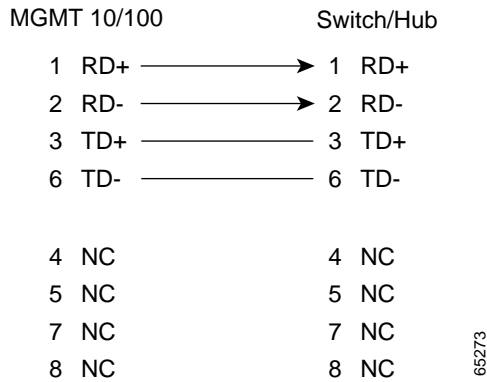


**Figure B-9 Two Twisted-Pair Crossover Cable Schematic for 10/100 Ports**

## Four Twisted-Pair Cable Pinouts for 10/100 Ports

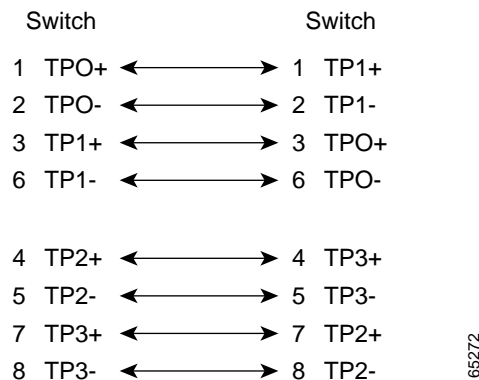
[Figure B-10](#) and [Figure B-11](#) show the schematics of four twisted-pair cables for 10/100 ports.

**Figure B-10 Four Twisted-Pair Straight-Through Cable Schematic for 10/100 Ports**

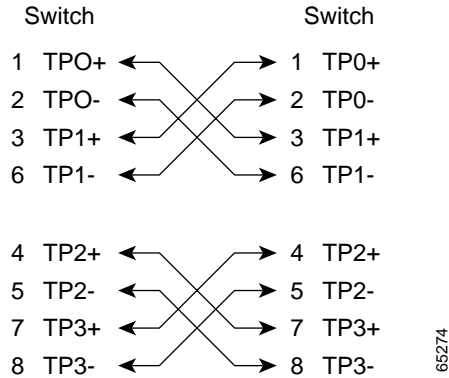
**Figure B-11 Four Twisted-Pair Crossover Cable Schematic for 10/100 Ports**

## Four Twisted-Pair Cable Pinouts for 1000BASE-T Ports

[Figure B-12](#) and [Figure B-13](#) show the schematics of four twisted-pair cables for 10/100/1000 ports on Catalyst 2950T-24 switches, Catalyst 2950 LRE switches, and 1000BASE-T GBIC module ports.

**Figure B-12 Four Twisted-Pair Straight-Through Cable Schematic for 10/100/1000 and 1000BASE-T GBIC Module Ports**

**Figure B-13 Four Twisted-Pair Crossover Cable Schematics for 10/100/1000 and 1000BASE-T GBIC Module Ports**



## RJ-21 Cable Pinouts

[Table B-1](#) lists the RJ-21 cable pinouts on the Catalyst 2950ST-24 LRE and Catalyst 2950ST-24 LRE 997 switches.

[Table B-2](#) lists the RJ-21 cable pinouts on the Catalyst 2950ST-8 LRE switches.

**Table B-1 RJ-21 Cable Pinouts on the Catalyst 2950ST-24 LRE and Catalyst 2950ST-24 LRE 997 Switches**

Function	Pin	Pin	Function
Port 1 Tip	1	26	Port 1 Ring
Port 2 Tip	2	27	Port 2 Ring
Port 3 Tip	3	28	Port 3 Ring
Port 4 Tip	4	29	Port 4 Ring
Port 5 Tip	5	30	Port 5 Ring
Port 6 Tip	6	31	Port 6 Ring
Port 7 Tip	7	32	Port 7 Ring
Port 8 Tip	8	33	Port 8 Ring
Port 9 Tip	9	34	Port 9 Ring

**Table B-1** *RJ-21 Cable Pinouts on the Catalyst 2950ST-24 LRE and Catalyst 2950ST-24 LRE 997 Switches (continued)*

Function	Pin	Pin	Function
Port 10 Tip	10	35	Port 10 Ring
Port 11 Tip	11	36	Port 11 Ring
Port 12 Tip	12	37	Port 12 Ring
Port 13 Tip	13	38	Port 13 Ring
Port 14 Tip	14	39	Port 14 Ring
Port 15 Tip	15	40	Port 15 Ring
Port 16 Tip	16	41	Port 16 Ring
Port 17 Tip	17	42	Port 17 Ring
Port 18 Tip	18	43	Port 18 Ring
Port 19 Tip	19	44	Port 19 Ring
Port 20 Tip	20	45	Port 20 Ring
Port 21 Tip	21	46	Port 21 Ring
Port 22 Tip	22	47	Port 22 Ring
Port 23 Tip	23	48	Port 23 Ring
Port 24 Tip	24	49	Port 24 Ring
No connect	25	50	No connect

**Table B-2 RJ-21 Cable Pinouts on the Catalyst 2950ST-8 LRE Switches**

Function	Pin	Pin	Function
Port 1 Tip	1	26	Port 1 Ring
Port 2 Tip	2	27	Port 2 Ring
Port 3 Tip	3	28	Port 3 Ring
Port 4 Tip	4	29	Port 4 Ring
Port 5 Tip	5	30	Port 5 Ring
Port 6 Tip	6	31	Port 6 Ring
Port 7 Tip	7	32	Port 7 Ring
Port 8 Tip	8	33	Port 8 Ring
No connect	9	34	No connect
No connect	10	35	No connect
No connect	11	36	No connect
No connect	12	37	No connect
No connect	13	38	No connect
No connect	14	39	No connect
No connect	15	40	No connect
No connect	16	41	No connect
No connect	17	42	No connect
No connect	18	43	No connect
No connect	19	44	No connect
No connect	20	45	No connect
No connect	21	46	No connect
No connect	22	47	No connect
No connect	23	48	No connect
No connect	24	49	No connect
No connect	25	50	No connect

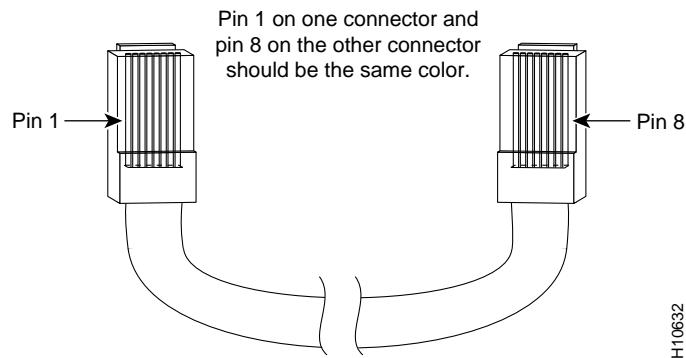
## Rollover Cable and Adapter Pinouts

This section describes how to identify a rollover cable and also describes the adapter pinouts.

### Identifying a Rollover Cable

You can identify a rollover cable by comparing the two modular cable ends. Hold the cable ends side-by-side, with the tab at the back. The wire connected to the pin on the outside of the left plug should be the same color as the wire connected to the pin on the outside of the right plug. (See [Figure B-14](#).)

**Figure B-14** *Identifying a Rollover Cable*





## Adapter Pinouts

[Table B-3](#) lists the pinouts for the console port, the RJ-45-to-DB-9 adapter cable, and the console device.

**Table B-3 Console Port Signaling and RJ-45-to-DB-9 Adapter Cabling**

Console Port (DTE)	RJ-45-to-DB-9 Adapter Cable		Console Device
Signal	RJ-45 Pin	DB-9 Pin	Signal
RTS	1	8	CTS
Not connected	2	6	DSR
TxD	3	2	RxD
GND	4	5	GND
GND	5	5	GND
RxD	6	3	TxD
Not connected	7	4	DTR
CTS	8	7	RTS

[Table B-4](#) lists the pinouts for the console port, RJ-45-to-DB-25 female DTE adapter, and the console device.



### Note

The RJ-45-to-DB-25 female DTE adapter is not supplied with the switch. You can order a kit (part number ACS-DSBUASYN=) with that adapter from Cisco.

**Table B-4 Console Port Signaling and Cabling Using a DB-25 Adapter**

Console Port (DTE)	RJ-45-to-DB-9 Adapter Cable		RJ-45-to-DB-25 Terminal Adapter	Console Device
Signal	RJ-45 Pin	DB-9 Pin	DB-25 Pin	Signal
RTS	1	8	5	CTS
Not connected	2	6	6	DSR
TxD	3	2	3	RxD
GND	4	5	7	GND
GND	5	5	7	GND
RxD	6	3	2	TxD
Not connected	7	4	20	DTR
CTS	8	7	4	RTS



## Connecting to DC Power

---

To connect the Catalyst 2950G-24-EI-DC or Catalyst 2950ST-24 LRE 997 switch to a direct current (DC)-input power source, follow these steps:

1. [Preparing for Installation, page C-2](#)
2. [Grounding the Switch, page C-2](#)
3. [Wiring the DC-Input Power Source, page C-5](#)



Warning

---

The Catalyst 2950G-24-EI-DC contains no field-replaceable units (FRUs). Do not open the chassis or attempt to remove or replace any components. For information about obtaining service for this unit, contact your reseller or Cisco sales representative.

---



Warning

---

The Catalyst 2950ST-24 LRE 997 contains no field-replaceable units (FRUs). Do not open the chassis or attempt to remove or replace any components. For information about obtaining service for this unit, contact your reseller or Cisco sales representative.

---



Warning

---

The equipment is to be installed in a restricted access area.

---



Warning

---

Ethernet cables must be shielded when used in a central office environment.

---

# Preparing for Installation

Locate the DC terminal block plug, the ground lug, and the two number-10-32 screws in the DC-switch kit.

Obtain these necessary tools and equipment:

- Ratcheting torque screwdriver with a Phillips head that exerts up to 15 pound-force inches (lbf-in.) of pressure
- Panduit crimping tool with optional controlled cycle mechanism (model CT-700, CT-720, CT-920, CT-920CH, CT-930, or CT-940CH)
- 6-gauge copper ground wire (insulated or noninsulated)
- Four leads of 18-gauge copper wire
- Wire-stripping tools for stripping 6- and 18-gauge wires

# Grounding the Switch



Warning

---

**This equipment is intended to be grounded. Ensure that the host is connected to earth ground during normal use.**

---



Warning

---

**When installing the unit, always make the ground connection first and disconnect it last.**

---



Caution

---

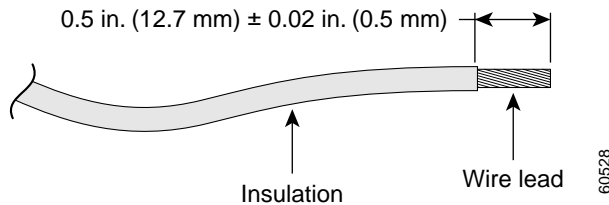
To make sure that the equipment is reliably connected to earth ground, follow the grounding procedure instructions, and use a UL-listed lug suitable for number-6 AWG wire and two number-10-32 ground-lug screws.

---

To ground the switch to earth ground, follow these steps. Make sure to follow any grounding requirements at your site.

- Step 1** Locate the ground lug and the two number-10-32 screws. The ground lug and screws are on the rear panel of the Catalyst 2950G-24-EI-DC switch or on the front panel of the Catalyst 2950ST-24 LRE 997 switch.
- Use a standard Phillips screwdriver or a ratcheting torque screwdriver with a Phillips head. Set the screws and the ground lug aside.
- Step 2** If your ground wire is insulated, use a wire stripping tool to strip the 6-gauge ground wire to 0.5 inch (12.7 millimeter [mm])  $\pm$  0.02 inch (0.5 mm) as shown in [Figure C-1](#).

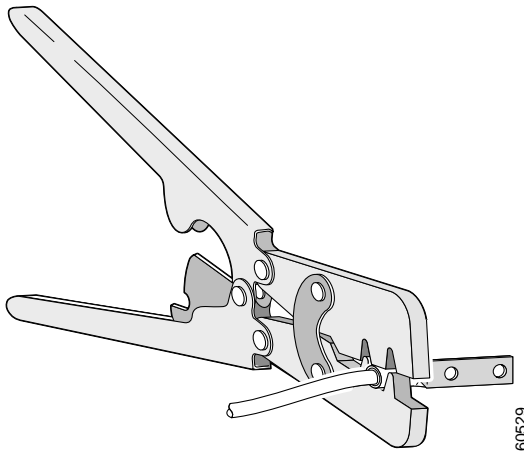
**Figure C-1** Stripping the Ground Wire



- Step 3** Slide the open end of the ground lug over the exposed area of the 6-gauge wire.

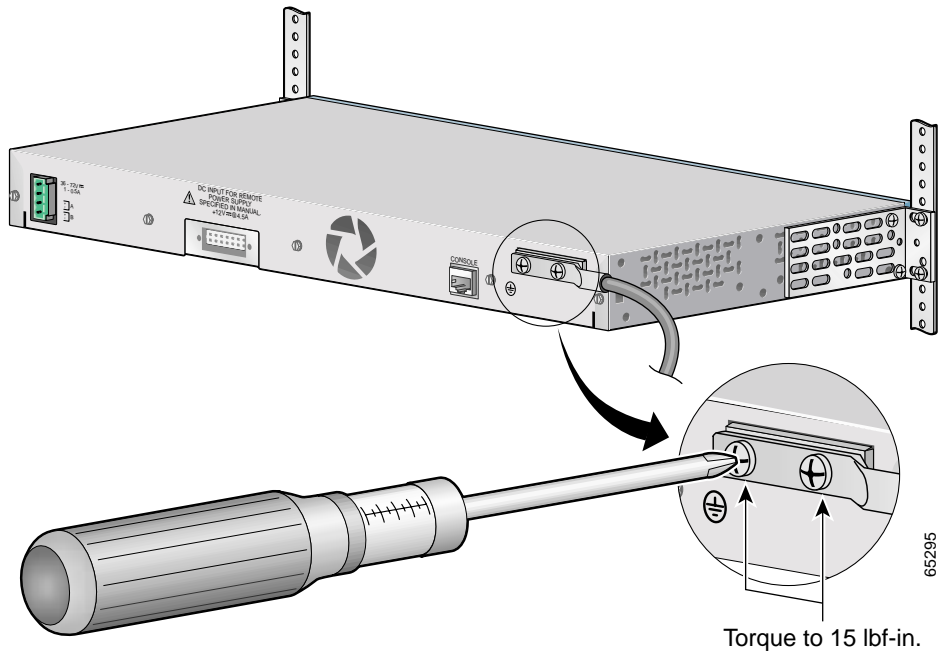
- Step 4** Using a Panduit crimping tool, crimp the ground lug to the 6-gauge wire.

**Figure C-2** Crimping the Ground Lug



- Step 5** Use the two number-10-32 screws to attach the ground lug and wire assembly to the rear panel of the Catalyst 2950G-24-EI-DC switch or to the front panel of the Catalyst 2950ST-24 LRE 997 switch.
- Step 6** Using a ratcheting torque screwdriver, torque each ground-lug screw to 15 lbf-in. (240 ounce-force inches [ozf-in.]). [Figure C-3](#) shows how to torque the ground screws on a Catalyst 2950G-24-EI-DC switch.

Figure C-3 Torquing Ground-Lug Screws



## Wiring the DC-Input Power Source



Warning

Only trained and qualified personnel should be allowed to install or replace this equipment.



Warning

Before performing any of the following procedures, ensure that power is removed from the DC circuit. To ensure that all power is OFF, locate the circuit breaker on the panel board that services the DC circuit, switch the circuit breaker to the OFF position, and tape the switch handle of the circuit breaker in the OFF position.

**Caution**

You must connect the Catalyst 2950G-24-EI-DC or Catalyst 2950ST-24 LRE 997 switch only to a DC-input power source that has an input supply voltage from  $-36$  to  $-72$  VDC. If the supply voltage is not in this range, the switch might not operate properly or might be damaged.

**Caution**

The switch must be installed with 5A-branch-circuit protection.

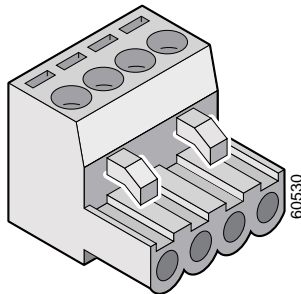
**Note**

This installation must comply with all applicable codes.

To wire the switch to a DC-input power source, follow these steps:

- Step 1** Locate the terminal block plug (see [Figure C-4](#)).

**Figure C-4** Terminal Block Plug

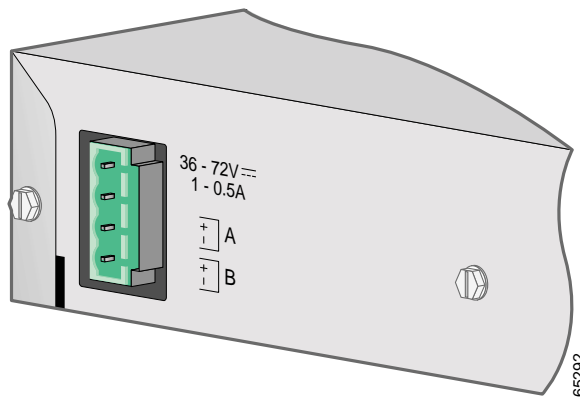




- Step 2** Identify the positive and negative feed positions for the terminal block connection. The wiring sequence is positive to positive and negative to negative for both the A and the B feed wires.

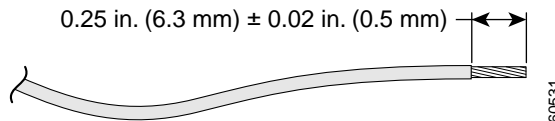
The rear panel of the Catalyst 2950G-24-EI-DC switch or the front panel of the Catalyst 2950ST-24 LRE 997 switch identifies the positive and negative positions for both the A and B feed wires. [Figure C-5](#) shows the positions on the Catalyst 2950G-24-EI-DC switch.

**Figure C-5** Positive and Negative Positions



- Step 3** Using an 18-gauge wire-stripping tool, strip each of the four wires coming from the DC-input power source to 0.27 inch (6.6 mm)  $\pm$  0.02 inch (0.5 mm). Do not strip more than 0.29 inch (7.4 mm) of insulation from the wire. Stripping more than the recommended amount of wire can leave exposed wire from the terminal block plug after installation.

**Figure C-6** Stripping the DC-Input Power Source Wire

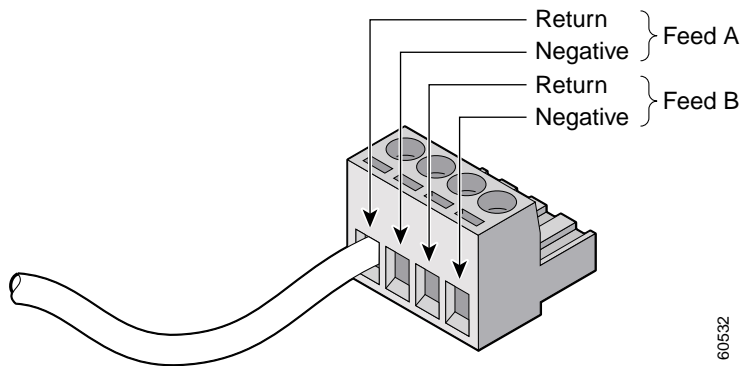


- Step 4** Insert the exposed wire of one of the four DC-input power source wires into the terminal block plug, as shown in [Figure C-7](#). Make sure that you cannot see any wire lead. Only wire *with insulation* should extend from the terminal block.

**Warning**

An exposed wire lead from a DC-input power source can conduct harmful levels of electricity. Be sure that no exposed portion of the DC-input power source wire extends from the terminal block plug.

*Figure C-7 Inserting Wires in the Terminal Block Plug*

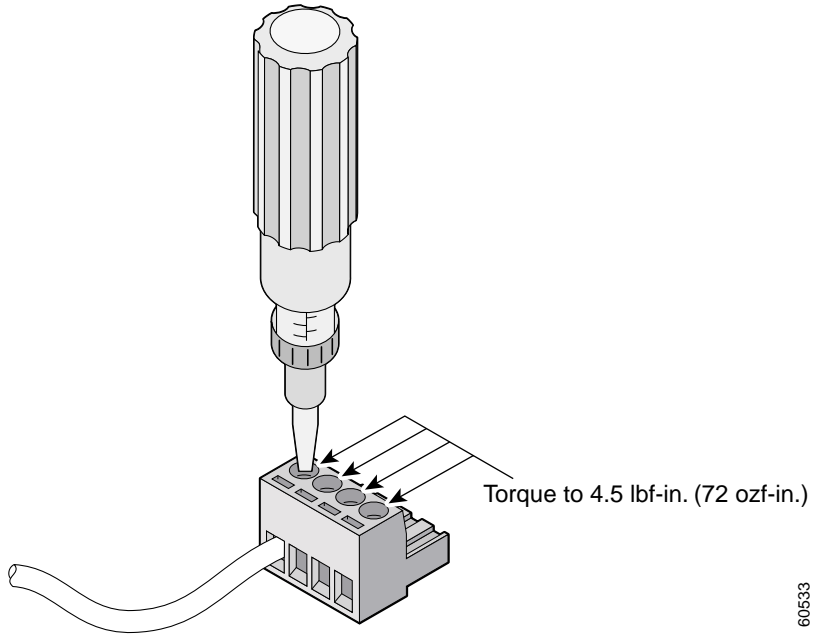


- Step 5** Use a ratcheting torque screwdriver to torque the terminal block captive screw (above the installed wire lead) to 4.5 lbf-in. (72 ozf-in.). (See [Figure C-8](#).)

**Caution**

Do not overtorque the terminal-block captive screws. The recommended maximum torque is 4.5 lbf-in.

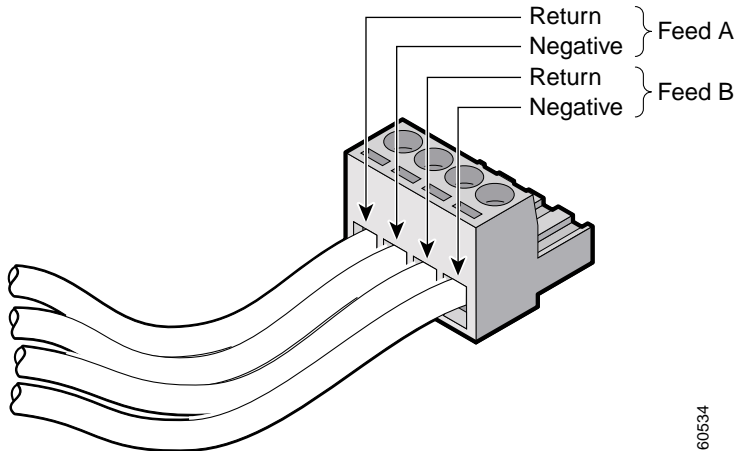
*Figure C-8 Torquing the Terminal-Block Captive Screws*



60533

- Step 6** Repeat Steps 4 and 5 for the remaining three DC-input power source wires. [Figure C-9](#) shows the completed wiring of a terminal block plug.

**Figure C-9** Completed Wiring of Terminal Block Plug



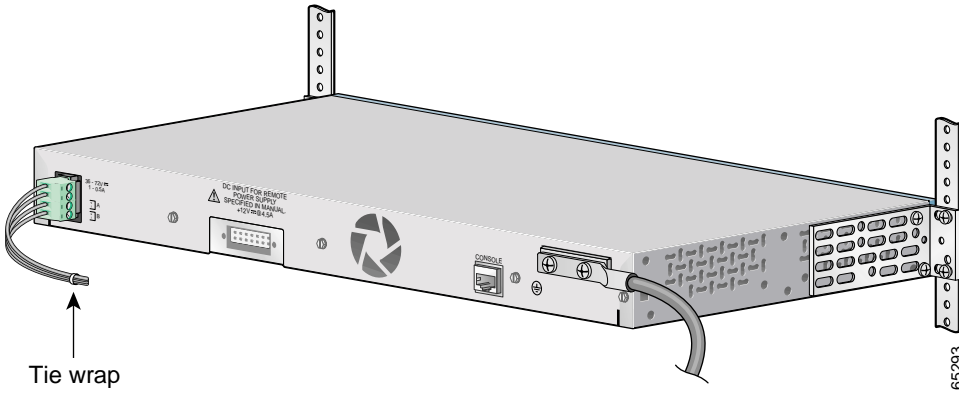
- Step 7** Insert the terminal block plug in the terminal block header on the rear panel of the Catalyst 2950G-24-EI-DC switch or on the front panel of the Catalyst 2950ST-24 LRE 997 switch. [Figure C-10](#) shows how to insert the terminal block on a Catalyst 2950G-24-EI-DC switch.



**Caution**

Secure the wires coming in from the terminal block so that they cannot be disturbed by casual contact. For example, use tie wraps to secure the wires to the rack.

Figure C-10 Inserting the Terminal Block in the Block Header



- Step 8** Remove the tape from the circuit-breaker switch handle, and move the circuit-breaker handle to the on position.
-

■ Wiring the DC-Input Power Source



## Translated Safety Warnings

---

This appendix repeats in multiple languages the warnings in this guide. These translated warnings can be used with other documents related to this guide.

### Attaching the Cisco RPS (model PWR300-AC-RPS-N1)



**Warning**

**Attach only the Cisco RPS (model PWR300-AC-RPS-N1) to the RPS receptacle.**

**Waarschuwing**

**Slechts de Cisco RPS (model PWR300-AC-RPS-N1) aan de RPS contactdoos verbinden.**

**Varoitus**

**Kiinnitä RPS-vastakappaleeseen vain Cisco RPS (malli PWR300-AC-RPS-N1).**

**Avertissement**

**Raccordez le bloc d'alimentation Cisco RPS (modèle PWR300-AC-RPS-N1) uniquement au connecteur RPS.**

**Warnung**

**An die RPS-Steckhülse darf nur das Cisco RPS (Modell PWR300-AC-RPS-N1) angeschlossen werden.**

## ■ Attaching the Cisco RPS (model PWR675-AC-RPS-N1)

<b>Figyelem!</b>	<b>Az RPS csatlakozóhoz csak Cisco RPS (PWR300-AC-RPS-N1 modell) aljzatot csatlakoztasson.</b>
<b>Avvertenza</b>	<b>Collegare soltanto il Cisco RPS (modello PWR300-AC-RPS-N1) alla presa RPS.</b>
<b>Advarsel!</b>	<b>Koble bare Cisco RPS (modell PWR300-AC-RPS-N1) til RPS-stikkkontakten.</b>
<b>Aviso</b>	<b>Anexe o RPS Cisco (modelo PWR300-AC-RPS-N1) apenas ao receptáculo RPS.</b>
<b>¡Advertencia!</b>	<b>Sólo conecte el Cisco RPS (modelo PWR300-AC-RPS-N1) al receptáculo RPS.</b>
<b>Varning!</b>	<b>Koppla endast Ciscos RPS (modell PWR300-AC-RPS-N1) till RPS-uttaget.</b>
<b>Предупреждение</b>	<b>К гнезду RPS можно подключать только системы питания Cisco RPS (модель PWR300-AC-RPS-N1).</b>
<b>警告</b>	<b>只能将 Cisco RPS (型号 PWR300-AC-RPS-N1) 连接到 RPS 插座。</b>
<b>警告</b>	<b>RPS レセプタクルには、Cisco RPS (モデル番号 PWR300-AC-RPS-N1) だけを接続してください。</b>

# Attaching the Cisco RPS (model PWR675-AC-RPS-N1)



**Warning**

**Attach only the Cisco RPS (model PWR675-AC-RPS-N1) to the RPS receptacle.**

**Waarschuwing**

**Slechts de Cisco RPS (model PWR675-AC-RPS-N1) aan de RPS contactdoos verbinden.**

**Varoitus**

**Kiinnitä RPS-vastakappaleeseen vain Cisco RPS (malli PWR675-AC-RPS-N1).**



<b>Avertissement</b>	<b>Raccordez le bloc d'alimentation Cisco RPS (modèle PWR675-AC-RPS-N1) uniquement au connecteur RPS.</b>
<b>Warnung</b>	<b>An die RPS-Steckhülse darf nur das Cisco RPS (Modell PWR675-AC-RPS-N1) angeschlossen werden.</b>
<b>Figyelem!</b>	<b>Az RPS csatlakozóhoz csak Cisco RPS (PWR675-AC-RPS-N1 modell) aljzatot csatlakoztasson.</b>
<b>Avvertenza</b>	<b>Collegare soltanto il Cisco RPS (modello PWR675-AC-RPS-N1) alla presa RPS.</b>
<b>Advarsel!</b>	<b>Koble bare Cisco RPS (modell PWR675-AC-RPS-N1) til RPS-stikkontaktene.</b>
<b>Aviso</b>	<b>Anexe o RPS Cisco (modelo PWR675-AC-RPS-N1) apenas ao receptáculo RPS.</b>
<b>¡Advertencia!</b>	<b>Sólo conecte el Cisco RPS (modelo PWR675-AC-RPS-N1) al receptáculo RPS.</b>
<b>Varning!</b>	<b>Koppla endast Ciscos RPS (modell PWR675-AC-RPS-N1) till RPS-uttaget.</b>
<b>Предупреждение</b>	<b>К гнезду RPS можно подключать только системы питания Cisco RPS (модель PWR675-AC-RPS-N1=).</b>
<b>警告</b>	<b>只能将 Cisco RPS (型号 PWR675-AC-RPS-N1=) 连接到 RPS 插座。</b>
<b>警告</b>	<b>RPS レセプタクルには、Cisco RPS (モデル番号 PWR675-AC-RPS-N1=) だけを接続してください。</b>

---

# Lightning Activity Warning



**Warning**

Do not work on the system or connect or disconnect cables during periods of lightning activity.

**Waarschuwing**

Tijdens onweer dat gepaard gaat met bliksem, dient u niet aan het systeem te werken of kabels aan te sluiten of te ontkoppelen.

**Varoitus**

Älä työskentele järjestelmän parissa äläkä yhdistä tai irrota kaapeleita ukkosilmalla.

**Attention**

Ne pas travailler sur le système ni brancher ou débrancher les câbles pendant un orage.

**Warnung**

Arbeiten Sie nicht am System und schließen Sie keine Kabel an bzw. trennen Sie keine ab, wenn es gewittert.

**Figyelem!**

Villámlás közben ne dolgozzon a rendszeren, valamint ne csatlakoztasson és ne húzzon ki kábeleket!

**Avvertenza**

Non lavorare sul sistema o collegare oppure scollegare i cavi durante un temporale con fulmini.

**Advarsel**

Utfør aldri arbeid på systemet, eller koble kabler til eller fra systemet når det tordner eller lyner.

**Aviso**

Não trabalhe no sistema ou ligue e desligue cabos durante períodos de mau tempo (trovoada).

**¡Advertencia!**

No operar el sistema ni conectar o desconectar cables durante el transcurso de descargas eléctricas en la atmósfera.

**Varning!**

Vid åska skall du aldrig utföra arbete på systemet eller ansluta eller koppla loss kablar.

<b>Предупреждение</b>	Не следует работать с устройством, а также подключать или отключать кабели во время грозы.
<b>警告</b>	请勿在发生雷电时操作系统，也不要在此期间连接或断开电缆。
<b>警告</b>	雷が発生しているときは、システムに手を加えたり、ケーブルの接続や取り外しを行わないでください。

---

## Installation Warning



### Warning

Read the installation instructions before connecting the system to the power source.

### Waarschuwing

Raadpleeg de installatie-instructies voordat u het systeem op de voedingsbron aansluit.

### Varoitus

Lue asennusohjeet ennen järjestelmän yhdistämistä virtalähteeseen.

### Attention

Avant de brancher le système sur la source d'alimentation, consulter les directives d'installation.

### Warnung

Vor dem Anschließen des Systems an die Stromquelle die Installationsanweisungen lesen.

### Figyelem!

Mielőtt áramforráshoz csatlakoztatná a rendszert, olvassa el az üzembe helyezési útmutatót!

### Avvertenza

Consultare le istruzioni di installazione prima di collegare il sistema all'alimentatore.

### Advarsel

Les installasjonsinstruksjonene før systemet kobles til strømkilden.

## Main Disconnecting Device

**Aviso** Leia as instruções de instalação antes de ligar o sistema à fonte de energia.

**¡Advertencia!** Lea las instrucciones de instalación antes de conectar el sistema a la red de alimentación.

**Varning!** Läs installationsanvisningarna innan du kopplar systemet till strömförsörjningsenheten.

**Предупреждение** Перед подключением устройства к источнику электропитания ознакомьтесь с данной инструкцией по установке.

**警告** 在将系统与电源连接之前，请仔细阅读安装说明。

**警告** 必ず設置手順を読んでから、システムを電源に接続してください。

## Main Disconnecting Device



**Warning**

The plug-socket combination must be accessible at all times, because it serves as the main disconnecting device.

**Waarschuwing** De combinatie van de stekker en het elektrisch contactpunt moet te allen tijde toegankelijk zijn omdat deze het hoofdmecanisme vormt voor verbreking van de aansluiting.

**Varoitus** Pistoke/liitinkohta toimii pääkatkaisumekanismina. Pääsy siihen on pidettävä aina esteettömänä.

**Attention** La combinaison de prise de courant doit être accessible à tout moment parce qu'elle fait office de système principal de déconnexion.

<b>Warnung</b>	Der Netzkabelanschluß am Gerät muß jederzeit zugänglich sein, weil er als primäre Ausschaltvorrichtung dient.
<b>Figyelem!</b>	A dugaszolóaljzat és a dugasz együttesének mindig hozzáférhetőnek kell lennie, mivel ez szolgál főmegszakítóként.
<b>Avvertenza</b>	Il gruppo spina-presa deve essere sempre accessibile, poiché viene utilizzato come dispositivo di scollegamento principale.
<b>Advarsel</b>	Kombinasjonen støpsel/uttak må alltid være tilgjengelig ettersom den fungerer som hovedfrakoplingsenhet.
<b>Aviso</b>	A combinação ficha-tomada deverá ser sempre acessível, porque funciona como interruptor principal.
<b>¡Advertencia!</b>	El conjunto de clavija y toma ha de encontrarse siempre accesible ya que hace las veces de dispositivo de desconexión principal.
<b>Varning!</b>	Man måste alltid kunna komma åt stickproppen i uttaget, eftersom denna koppling utgör den huvudsakliga frånkopplingsanordningen.
<b>Предупреждение</b>	Штепсельная розетка всегда должна быть доступна, поскольку она служит основным устройством отключения.
<b>警告</b>	插销和插座必须便于随时插拔，因为它是主要断电设备。
<b>警告</b>	主要な切断装置となるので、プラグとソケットは常に手が届く場所に置く必要があります。

# Chassis Warning—Rack-Mounting and Servicing



## Warning

To prevent bodily injury when mounting or servicing this unit in a rack, you must take special precautions to ensure that the system remains stable. The following guidelines are provided to ensure your safety:

- This unit should be mounted at the bottom of the rack if it is the only unit in the rack.
- When mounting this unit in a partially filled rack, load the rack from the bottom to the top with the heaviest component at the bottom of the rack.
- If the rack is provided with stabilizing devices, install the stabilizers before mounting or servicing the unit in the rack.

## Waarschuwing

Om lichamelijk letsel te voorkomen wanneer u dit toestel in een rek monteert of het daar een servicebeurt geeft, moet u speciale voorzorgsmaatregelen nemen om ervoor te zorgen dat het toestel stabiel blijft. De onderstaande richtlijnen worden verstrekt om uw veiligheid te verzekeren:

- Dit toestel dient onderaan in het rek gemonteerd te worden als het toestel het enige in het rek is.
- Wanneer u dit toestel in een gedeeltelijk gevuld rek monteert, dient u het rek van onderen naar boven te laden met het zwaarste onderdeel onderaan in het rek.
- Als het rek voorzien is van stabiliseringshulpmiddelen, dient u de stabilisatoren te monteren voordat u het toestel in het rek monteert of het daar een servicebeurt geeft.

## Varoitus

Kun laite asetetaan telineeseen tai huolletaan sen ollessa telineessä, on noudatettava erityisiä varotoimia järjestelmän vakavuuden säilyttämiseksi, jotta vältetään loukkaantumiset. Noudata seuraavia turvallisuusohjeita:

- Jos telineessä ei ole muita laitteita, aseta laite telineen alaosaan.
- Jos laite asetetaan osaksi täytettyyn telineeseen, aloita kuormittaminen sen alaosasta kaikkein raskaimmalla esineellä ja siirry sitten sen yläosaan.
- Jos telinettä varten on vakaimet, asenna ne ennen laitteen asettamista telineeseen tai sen huoltamista siinä.

- Attention** Pour éviter toute blessure corporelle pendant les opérations de montage ou de réparation de cette unité en casier, il convient de prendre des précautions spéciales afin de maintenir la stabilité du système. Les directives ci-dessous sont destinées à assurer la protection du personnel:
- Si cette unité constitue la seule unité montée en casier, elle doit être placée dans le bas.
  - Si cette unité est montée dans un casier partiellement rempli, charger le casier de bas en haut en plaçant l'élément le plus lourd dans le bas.
  - Si le casier est équipé de dispositifs stabilisateurs, installer les stabilisateurs avant de monter ou de réparer l'unité en casier.
- Warnung** Zur Vermeidung von Körperverletzung beim Anbringen oder Warten dieser Einheit in einem Gestell müssen Sie besondere Vorkehrungen treffen, um sicherzustellen, daß das System stabil bleibt. Die folgenden Richtlinien sollen zur Gewährleistung Ihrer Sicherheit dienen:
- Wenn diese Einheit die einzige im Gestell ist, sollte sie unten im Gestell angebracht werden.
  - Bei Anbringung dieser Einheit in einem zum Teil gefüllten Gestell ist das Gestell von unten nach oben zu laden, wobei das schwerste Bauteil unten im Gestell anzubringen ist.
  - Wird das Gestell mit Stabilisierungszubehör geliefert, sind zuerst die Stabilisatoren zu installieren, bevor Sie die Einheit im Gestell anbringen oder sie warten.
- Figyelem!** A készülék rackbe történő beszerelése és karbantartása során bekövetkező sérülések elkerülése végett speciális óvintézkedésekkel meg kell őrizni a rendszer stabilitását. A személyes biztonsága érdekében tartsa be a következő szabályokat:
- Ha a rackben csak ez az egy készülék található, a rack aljába kell beszerelni.
  - Ha nincs teljesen tele az a rack, amelybe beszerelik a készüléket, alulról fölfelé haladva töltsse fel a racket úgy, hogy a legnehezebb készülék kerüljön a rack aljába.
  - Ha stabilizáló eszközök is tartoznak a rackhez, szerelje fel a stabilizátorokat, mielőtt beszerelné az egységet a rackbe, vagy karbantartást végezne rajta.

- Avvertenza** Per evitare infortuni fisici durante il montaggio o la manutenzione di questa unità in un supporto, occorre osservare speciali precauzioni per garantire che il sistema rimanga stabile. Le seguenti direttive vengono fornite per garantire la sicurezza personale:
- Questa unità deve venire montata sul fondo del supporto, se si tratta dell'unica unità da montare nel supporto.
  - Quando questa unità viene montata in un supporto parzialmente pieno, caricare il supporto dal basso all'alto, con il componente più pesante sistemato sul fondo del supporto.
  - Se il supporto è dotato di dispositivi stabilizzanti, installare tali dispositivi prima di montare o di procedere alla manutenzione dell'unità nel supporto.
- Advarsel** Unngå fysiske skader under montering eller reparasjonsarbeid på denne enheten når den befinner seg i et kabinett. Vær nøye med at systemet er stabilt. Følgende retningslinjer er gitt for å verne om sikkerheten:
- Denne enheten bør monteres nederst i kabinettet hvis dette er den eneste enheten i kabinettet.
  - Ved montering av denne enheten i et kabinett som er delvis fylt, skal kabinettet lastes fra bunnen og opp med den tyngste komponenten nederst i kabinettet.
  - Hvis kabinettet er utstyrt med stabiliseringsutstyr, skal stabilisatorene installeres før montering eller utføring av reparasjonsarbeid på enheten i kabinettet.
- Aviso** Para se prevenir contra danos corporais ao montar ou reparar esta unidade numa estante, deverá tomar precauções especiais para se certificar de que o sistema possui um suporte estável. As seguintes directrizes ajudá-lo-ão a efectuar o seu trabalho com segurança:
- Esta unidade deverá ser montada na parte inferior da estante, caso seja esta a única unidade a ser montada.
  - Ao montar esta unidade numa estante parcialmente ocupada, coloque os itens mais pesados na parte inferior da estante, arrumando-os de baixo para cima.
  - Se a estante possuir um dispositivo de estabilização, instale-o antes de montar ou reparar a unidade.



- ¡Advertencia!** Para evitar lesiones durante el montaje de este equipo sobre un bastidor, o posteriormente durante su mantenimiento, se debe poner mucho cuidado en que el sistema quede bien estable. Para garantizar su seguridad, proceda según las siguientes instrucciones:
- Colocar el equipo en la parte inferior del bastidor, cuando sea la única unidad en el mismo.
  - Cuando este equipo se vaya a instalar en un bastidor parcialmente ocupado, comenzar la instalación desde la parte inferior hacia la superior colocando el equipo más pesado en la parte inferior.
  - Si el bastidor dispone de dispositivos estabilizadores, instalar éstos antes de montar o proceder al mantenimiento del equipo instalado en el bastidor.

**Varning!** För att undvika kroppsskada när du installerar eller utför underhållsarbete på denna enhet på en ställning måste du vidta särskilda försiktighetsåtgärder för att försäkra dig om att systemet står stadigt. Följande riktlinjer ges för att trygga din säkerhet:

- Om denna enhet är den enda enheten på ställningen skall den installeras längst ned på ställningen.
- Om denna enhet installeras på en delvis fylld ställning skall ställningen fyllas nedifrån och upp, med de tyngsta enheterna längst ned på ställningen.
- Om ställningen är försedd med stabiliseringsdon skall dessa monteras fast innan enheten installeras eller underhålls på ställningen.

**Предупреждение** Во избежание травм при монтаже и обслуживании устройства в стойке следует принять особые меры предосторожности, чтобы убедиться в устойчивости оборудования. Для обеспечения безопасности работ необходимо соблюдать следующие правила.

- Если в стойке находится одно устройство, оно должно быть установлено в нижней части.
- При монтаже устройств в частично заполненную стойку устанавливайте оборудование снизу вверх, размещая наиболее тяжелые устройства в нижней части.
- Если стойка снабжена приспособлениями для стабилизации, их необходимо установить до начала монтажа или обслуживания оборудования.

## Overtemperature Warning

**警告** 为避免在机架中安装或维修该部件时使身体受伤，您必须采取特殊的预防措施确保系统固定。以下是确保安全的原则：

- 如果此部件是机架中唯一的部件，应将其安装在机架的底部。
- 如果在部分装满的机架中安装此部件，请按从下往上的顺序安装各个部件，并且最重的组件应安装在机架的底部。
- 如果机架配有固定装置，请先装好固定装置，然后再在机架中安装或维修部件。

**警告** この装置をラックに設置したり保守作業を行ったりするときは、人身事故を防ぐため、システムが安定しているかどうかを十分に確認する必要があります。次の注意事項に従ってください。

- ラックにこの装置を単独で設置する場合は、ラックの一番下に設置します。
- ラックに別の装置がすでに設置されている場合は、最も重量のある装置を一番下にして、重い順に下から上へ設置します。
- ラックに安定器具が付属している場合は、その安定器具を取り付けてから、装置をラックに設置するか、またはラック内の装置の保守作業を行ってください。

# Overtemperature Warning



## Warning

To prevent the switch from overheating, do not operate it in an area that exceeds the maximum recommended ambient temperature of 113°F (45°C). To prevent airflow restriction, allow at least 3 inches (7.6 cm) of clearance around the ventilation openings.

## Waarschuwing

Om oververhitting van de schakelaar te voorkomen, mag u die niet bedienen in een ruimte die de maximale aanbevolen omgevingstemperatuur van 113°F (45°C) overschrijdt. Om beperking van de luchtstroom te voorkomen, dient u ten minste 3 inch (7,6 cm) speling te laten rondom de ventilatie-openingen.

Varoitus	Estääksesi kytkimen ylikuumentumisen älä käytä sitä sellaisissa paikoissa, joiden lämpötila ylittää ympäristön enimmäislämpötilaksi suositellun 45°C. Jätä vähintään 7,6 cm:n vapaa tila tuuletusaukkojen ympärille, jotta ilma pääsee vapaasti virtaamaan.
Attention	Pour éviter une surchauffe du commutateur, ne pas le faire fonctionner dans un local dont la température ambiante dépasse le maximum recommandé de 45°C (113°F). Pour faciliter la circulation d'air, aménager un dégagement d'au moins 7,6 cm (3 pouces) autour des bouches d'aération.
Warnung	Um eine Überhitzung des Schalters zu vermeiden, ist das System nicht in einem Bereich zu betreiben, in dem die empfohlene Höchsttemperatur von 45°C überschritten wird. Damit der Luftfluß nicht behindert wird, ist ein Freiraum von mindestens 7,6 cm um die Belüftungsöffnungen herum einzuhalten.
Figyelem!	A túlmelegedés megelőzése végett ne üzemeltesse a kapcsolót olyan területen, ahol a hőmérséklet meghaladja a 45°C maximális ajánlott környezeti hőmérsékletet. A megfelelő légáramlás biztosítása érdekében a szellőzőnyílások körül hagyjon szabadon legalább 7,6 cm helyet.
Avvertenza	Per evitare il surriscaldamento dell'interruttore, non usare l'apparecchiatura in un'area che supera la temperatura ambientale minima consigliata di 45°C. Per evitare una limitazione del flusso dell'aria, lasciare come minimo uno spazio libero di 7,6 cm intorno alle aperture di ventilazione.
Advarsel	For å unngå at bryteren overopphetes skal utstyret ikke brukes på steder hvor anbefalt maks omgivelsestemperatur overstiger 113 grader Farenheit (45°C). La det være minst 3 tommer (7,6 cm) klaring rundt ventilasjonsåpningene for at luft sirkulasjonen skal være uhindret.
Aviso	Para evitar sobreaquecimento do interruptor, não utilize o equipamento numa área que exceda uma temperatura máxima de 45°C. Para evitar o bloqueamento da circulação de ar, deixe pelo menos um espaço de 7.6 cm em volta das aberturas de ventilação.

## No On/Off Switch Warning

**¡Advertencia!** Para evitar que el interruptor se recaliente, no se debe usar en áreas cuya temperatura ambiente exceda la máxima recomendada, esto es, 45°C (113°F). Para no entorpecer la corriente de aire, dejar por lo menos 7,6 cm (3 pulgadas) de espacio muerto alrededor de la rejilla de ventilación.

**Varning!** För att undvika överhettning av strömbrytaren skall den inte användas i utrymme vars temperatur överskrider den maximalt rekommenderade omgivningstemperaturen 45°C. Kontrollera att det finns minst 7,6 cm fritt utrymme runt ventilationsöppningarna så att luftflödet inte begränsas.

**Предупреждение** Во избежание перегрева переключателя его не следует использовать в помещениях, в которых температура воздуха выше максимальной рекомендованной: 113°F (45°C). Во избежание ограничения воздушного потока около вентиляционных отверстий должно быть не менее 3 дюймов (7,6 см) свободного пространства.

**警告** 为了防止开关过热，不要在超过所建议的最大环境温度华氏 113 度（摄氏 45 度）下运行该系统。为了防止空气流量受限，要在通风口周围至少留出 3 英寸（7.6 厘米）的空间。

**警告** スイッチの加熱を防ぐため、推奨されている最高周囲温度、摂氏 45 度（華氏 113 度）を超える場所で作業をしないでください。気流の停滞を防ぐため、換気孔から 7.6cm（3 インチ）以上の間隔をとってください。

## No On/Off Switch Warning



Warning

Unplug the power cord before you work on a system that does not have an on/off switch.

Waarschuwing

Voordat u aan een systeem werkt dat geen aan/uit schakelaar heeft, dient u de stekker van het netsnoer uit het stopcontact te halen.

<b>Varoitus</b>	<b>Ennen kuin teet mitään sellaiselle järjestelmälle, jossa ei ole kaksiasentokytkintä, kytke irti virtajohto.</b>
<b>Attention</b>	<b>Avant de travailler sur un système non équipé d'un commutateur marche-arrêt, débrancher le cordon d'alimentation.</b>
<b>Warnung</b>	<b>Bevor Sie an einem System ohne Ein/Aus-Schalter arbeiten, ziehen Sie das Netzkabel heraus.</b>
<b>Figyelem!</b>	<b>Húzza ki a tápkábelt, mielőtt egy olyan készüléken kezd el dolgozik, amelynek nincs ki/bekapcsoló gombja.</b>
<b>Avvertenza</b>	<b>Prima di lavorare su un sistema che non è dotato di un interruttore on/off, scollegare il cavo di alimentazione.</b>
<b>Advarsel</b>	<b>Før det skal utføres arbeid på et system som ikke har en av/på-bryter, skal strømledningen trekkes ut.</b>
<b>Aviso</b>	<b>Antes de começar a trabalhar num sistema que não possui um interruptor ON/OFF, desligue o cabo de alimentação.</b>
<b>¡Advertencia!</b>	<b>Antes de trabajar sobre cualquier sistema que carezca de interruptor de Encendido/Apagado (ON/OFF), desenchufar el cable de alimentación.</b>
<b>Varning!</b>	<b>Dra ur nätsladden innan du utför arbete på ett system utan strömbrytare.</b>
<b>Предупреждение</b>	<b>Выдерните вилку шнура питания из розетки, прежде чем приступить к работе с оборудованием, в котором отсутствует выключатель.</b>
<b>警告</b>	<b>在操作没有切换开关的系统以前，请拔出电源线。</b>
<b>警告</b>	<b>オン/オフ・スイッチを備えていないシステムで作業を行うときは、事前に電源コードをはずしてください。</b>

# Grounded Equipment Warning



## Warning

This equipment is intended to be grounded. Ensure that the host is connected to earth ground during normal use.

## Waarschuwing

Deze apparatuur hoort geaard te worden. Zorg dat de host-computer tijdens normaal gebruik met aarde is verbonden.

## Varoitus

Tämä laitteisto on tarkoitettu maadoitettavaksi. Varmista, että isäntälaitte on yhdistetty maahan normaalikäytön aikana.

## Attention

Cet équipement doit être relié à la terre. S'assurer que l'appareil hôte est relié à la terre lors de l'utilisation normale.

## Warnung

Dieses Gerät muß geerdet werden. Stellen Sie sicher, daß das Host-Gerät während des normalen Betriebs an Erde gelegt ist.

## Figyelem!

A készüléket védőföldeléssel kell ellátni. Győződjön meg róla, hogy a készülék normál használat során csatlakozik a földhöz.

## Avvertenza

Questa apparecchiatura deve essere collegata a massa. Accertarsi che il dispositivo host sia collegato alla massa di terra durante il normale utilizzo.

## Advarsel

Dette utstyret skal jordes. Forviss deg om vertsterminalen er jordet ved normalt bruk.

## Aviso

Este equipamento deverá estar ligado à terra. Certifique-se que o host se encontra ligado à terra durante a sua utilização normal.

## ¡Advertencia!

Este equipo debe conectarse a tierra. Asegurarse de que el equipo principal esté conectado a tierra durante el uso normal.

## Varning!

Denna utrustning är avsedd att jordas. Se till att värdenheten är jordad vid normal användning.

<b>Предупреждение</b>	Данное устройство должно быть заземлено. Убедитесь, что при обычной работе устройство заземлено.
<b>警告</b>	此设备应该接地。请确保主机在正常使用期间连接接地。
<b>警告</b>	この装置はアースに接続するものです。通常の使用では、ホストがアース端子に接続されていることを確認してください。

---

## Product Disposal Warning



### Warning

Ultimate disposal of this product should be handled according to all national laws and regulations.

### Waarschuwing

Het uiteindelijke wegruimen van dit product dient te geschieden in overeenstemming met alle nationale wetten en reglementen.

### Varoitus

Tämä tuote on hävitettävä kansallisten lakien ja määräysten mukaisesti.

### Attention

La mise au rebut ou le recyclage de ce produit sont généralement soumis à des lois et/ou directives de respect de l'environnement. Renseignez-vous auprès de l'organisme compétent.

### Warnung

Die Entsorgung dieses Produkts sollte gemäß allen Bestimmungen und Gesetzen des Landes erfolgen.

### Figyelem!

A készülék végső elhelyezéséről az adott országban érvényes törvények és előírások szerint kell intézkedni.

### Avvertenza

Lo smaltimento di questo prodotto deve essere eseguito secondo le leggi e regolazioni locali.

## Ground Connection Warning

<b>Advarsel</b>	<b>Endelig kassering av dette produktet skal være i henhold til alle relevante nasjonale lover og bestemmelser.</b>
<b>Aviso</b>	<b>Deitar fora este produto em conformidade com todas as leis e regulamentos nacionais.</b>
<b>¡Advertencia!</b>	<b>Al deshacerse por completo de este producto debe seguir todas las leyes y reglamentos nacionales.</b>
<b>Varning!</b>	<b>Vid deponering hanteras produkten enligt gällande lagar och bestämmelser.</b>

**Предупреждение** Окончательная установка данного изделия должна выполняться в соответствии со всеми региональными и местными правилами и нормами.

**警告** 本产品的废弃处理应根据所有国家的法律和规章进行。

**警告** この製品を廃棄するときは、各国の法律および規制に従って処理してください。

## Ground Connection Warning



**Warning**

**When installing the unit, always make the ground connection first and disconnect it last.**

**Waarschuwing**

**Bij de installatie van het toestel moet de aardverbinding altijd het eerste worden gemaakt en het laatste worden losgemaakt.**

**Varoitus**

**Laitetta asennettaessa on maahan yhdistäminen aina tehtävä ensiksi ja maadoituksen irti kytkeminen viimeiseksi.**



<b>Attention</b>	<b>Lors de l'installation de l'appareil, la mise à la terre doit toujours être connectée en premier et déconnectée en dernier.</b>
<b>Warnung</b>	<b>Der Erdanschluß muß bei der Installation der Einheit immer zuerst hergestellt und zuletzt abgetrennt werden.</b>
<b>Figyelem!</b>	<b>A készülék üzembe helyezése közben mindig a földelővezetéket kell elsőként csatlakoztatni és azt kell utolsóként leválasztani.</b>
<b>Avvertenza</b>	<b>In fase di installazione dell'unità, eseguire sempre per primo il collegamento a massa e disconnetterlo per ultimo.</b>
<b>Advarsel</b>	<b>Når enheten installeres, må jordledningen alltid tilkobles først og frakobles sist.</b>
<b>Aviso</b>	<b>Ao instalar a unidade, a ligação à terra deverá ser sempre a primeira a ser ligada, e a última a ser desligada.</b>
<b>¡Advertencia!</b>	<b>Al instalar el equipo, conectar la tierra la primera y desconectarla la última.</b>
<b>Varning!</b>	<b>Vid installation av enheten måste jordledningen alltid anslutas först och kopplas bort sist.</b>
<b>Предупреждение</b>	<b>При установке устройства контакт заземления должен подключаться первым, а отключаться последним.</b>
<b>警告</b>	<b>安装部件时，必须首先进行接地连接，而断开接地连接应在最后进行。</b>
<b>警告</b>	<b>ユニットを設置する場合、アース端子は常に最初に接続し、最後に切断してください。</b>

# Jewelry Removal Warning



## Warning

Before working on equipment that is connected to power lines, remove jewelry (including rings, necklaces, and watches). Metal objects will heat up when connected to power and ground and can cause serious burns or weld the metal object to the terminals.

## Waarschuwing

Alvorens aan apparatuur te werken die met elektrische leidingen is verbonden, sieraden (inclusief ringen, kettingen en horloges) verwijderen. Metalen voorwerpen worden warm wanneer ze met stroom en aarde zijn verbonden, en kunnen ernstige brandwonden veroorzaken of het metalen voorwerp aan de aansluitklemmen lassen.

## Varoitus

Ennen kuin työskentelet voimavirtajohtoihin kytkettyjen laitteiden parissa, ota pois kaikki korut (sormukset, kaulakorut ja kellot mukaan lukien). Metalliesineet kuumenevat, kun ne ovat yhteydessä sähkövirran ja maan kanssa, ja ne voivat aiheuttaa vakavia palovammoja tai hitsata metalliesineet kiinni liitäntänapoihin.

## Attention

Avant d'accéder à cet équipement connecté aux lignes électriques, ôter tout bijou (anneaux, colliers et montres compris). Lorsqu'ils sont branchés à l'alimentation et reliés à la terre, les objets métalliques chauffent, ce qui peut provoquer des blessures graves ou souder l'objet métallique aux bornes.

## Warnung

Vor der Arbeit an Geräten, die an das Netz angeschlossen sind, jeglichen Schmuck (einschließlich Ringe, Ketten und Uhren) abnehmen. Metallgegenstände erhitzen sich, wenn sie an das Netz und die Erde angeschlossen werden, und können schwere Verbrennungen verursachen oder an die Anschlußklemmen angeschweißt werden.

## Figyelem!

Mielőtt hálózati feszültséghez csatlakozó készülékkel kezd el dolgozni, vegye le magáról az ékszereket (például gyűrűt, nyakláncot, órát). A fém tárgyak felmelegszenek, ha hálózati feszültséghez és földhöz érnek, és súlyos égési sérülést okozhatnak, illetve a fém tárgyak hozzáforrhhatnak a csatlakozókhoz.

Avvertenza	Prima di intervenire su apparecchiature collegate alle linee di alimentazione, togliersi qualsiasi monile (inclusi anelli, collane, braccialetti ed orologi). Gli oggetti metallici si riscaldano quando sono collegati tra punti di alimentazione e massa: possono causare ustioni gravi oppure il metallo può saldarsi ai terminali.
Advarsel	Fjern alle smykker (inkludert ringer, halskjeder og klokker) før du skal arbeide på utstyr som er koblet til kraftledninger. Metallgjenstander som er koblet til kraftledninger og jord blir svært varme og kan forårsake alvorlige brannskader eller smelte fast til polene.
Aviso	Antes de trabalhar em equipamento que esteja ligado a linhas de corrente, retire todas as jóias que estiver a usar (incluindo anéis, fios e relógios). Os objectos metálicos aquecerão em contacto com a corrente e em contacto com a ligação à terra, podendo causar queimaduras graves ou ficarem soldados aos terminais.
¡Advertencia!	Antes de operar sobre equipos conectados a líneas de alimentación, quitarse las joyas (incluidos anillos, collares y relojes). Los objetos de metal se calientan cuando se conectan a la alimentación y a tierra, lo que puede ocasionar quemaduras graves o que los objetos metálicos queden soldados a los bornes.
Varning!	Tag av alla smycken (inklusive ringar, halsband och armbandsur) innan du arbetar på utrustning som är kopplad till kraftledningar. Metallobjekt hettas upp när de kopplas ihop med ström och jord och kan förorsaka allvarliga brännskador; metallobjekt kan också sammansvetsas med kontakterna.
Предупреждение	Прежде чем использовать оборудование, подключенное к электросети, снимите все украшения (включая кольца, ожерелья и часы). Металлические части нагреваются при соединении с источником питания и землей, что может привести к серьезным ожогам или привариванию металлических объектов к клеммам.

## Stacking the Chassis Warning

**警告** 在操作与电源线连接的设备以前，请取下首饰（包括戒指、项链和手表）。连接电源和接地后，金属物品会升温，可能导致严重灼伤，也可能使金属物品熔接在线端。

**警告** 電源に接続されている装置を取り扱う際は、事前に、指輪、ネックレス、腕時計などの装身具をはずしてください。金属のオブジェクトが電源とアースと接触すると、金属が過熱して大やけどをしたり、また金属類が端子に焼き付くことがあります。

# Stacking the Chassis Warning



## Warning

Do not stack the chassis on any other equipment. If the chassis falls, it can cause severe bodily injury and equipment damage.

## Waarschuwing

Het chassis mag niet op andere apparatuur gestapeld te worden. Als het chassis mocht vallen, kan dit ernstig lichamelijk letsel en beschadiging van de apparatuur veroorzaken.

## Varoitus

Älä aseta asennuspohjaa minkään muun laitteen päälle. Asennuspohja voi pudotessaan aiheuttaa vaikean ruumiinvamman tai laiteaurion.

## Avertissement

Ne placez pas ce châssis sur un autre appareil. En cas de chute, il pourrait provoquer de graves blessures corporelles et d'importants dommages.

## Achtung

Das Gehäuse nicht auf andere Geräte stellen. Wenn das Gehäuse herunterfällt, besteht Gefahr schwerer Personenverletzungen und Geräteschäden.

## Figyelem!

A készüléket ne tegye rá másik készülékre. Ha a készülék leesik, súlyos testi sérülést okozhat, és maga a készülék is megkárosodhat.

## Avvertenza

Non collocare lo chassis su nessun altro apparecchio. Se lo chassis cade, può causare lesioni gravi e danni alle apparecchiature.

<b>Advarsel</b>	<b>Stable ikke kabinettet oppå annet utstyr. Hvis kabinettet faller, kan det forårsake alvorlig skade på mennesker og utstyr.</b>
<b>Aviso</b>	<b>Não coloque o chassis em cima de qualquer outro equipamento. Se o chassis cair, poderá causar ferimentos graves e danos no equipamento.</b>
<b>¡Atención!</b>	<b>No apilar los chasis sobre ningún otro equipo. Si el chasis se cae al suelo puede causar graves lesiones físicas y daños al equipo.</b>
<b>Varning</b>	<b>Placera inte chassit ovanpå annan utrustning. Om chassit faller kan allvarlig kroppsskada såväl som skada på utrustningen uppstå.</b>
<b>Предупреждение</b>	<b>Не устанавливайте данное устройство на любое другое оборудование. Если устройство упадет, то это может привести к тяжелым травмам и повреждению оборудования.</b>
<b>警告</b>	<b>不要将底盘堆放在其它任何设备上。如果底盘倒下，可能使身体受伤并损坏设备。</b>
<b>警告</b>	<b>別のいかなる装置の上にもシャーシを載せないでください。シャーシを落とすと、大けがをしたり装置を損傷させたりする場合があります。</b>

## Switch Installation Warning



### Warning

To comply with safety regulations, mount switches on a wall with the front panel facing up.

### Waarschuwing

Om te voldoen aan de veiligheidsvoorschriften dient u de schakelaars op een muur te monteren met het voorpaneel omhoog.

### Varoitus

Turvallisuusmääräykset edellyttävät, että kytkimet kiinnitetään seinään etupaneeli ylöspäin.

■ Switch Installation Warning

**Attention** Pour satisfaire aux dispositions de sécurité, installez les commutateurs muraux avec le panneau frontal vers le haut.

**Warnung** Zur Einhaltung der Sicherheitsvorschriften die Schalter so an einer Wand montieren, dass die Frontplatte nach oben zeigt.

**Figyelem!** A biztonsági előírások betartása érdekében a kapcsolókat úgy szerelje a falra, hogy az előlapjuk felfelé nézzen.

**Avvertenza** In conformità ai regolamenti di sicurezza, installare i dispositivi switch a muro con il pannello frontale rivolto in su.

**Advarsel** For å etterkomme sikkerhetsreglene skal brytere monteres på en vegg med frontpanelet vendt opp.

**Aviso** Para cumprir com os regulamentos de segurança, faça a montagem de switches em uma parede com o painel frontal virado para cima.

**¡Advertencia!** Para cumplir con las reglas de seguridad, instale los interruptores en una pared con el panel del frente hacia arriba.

**Varning!** För att uppfylla säkerhetsföreskrifter skall omkopplarna monteras på en vägg med frampanelen riktad uppåt.

**Предупреждение** В соответствии с положениями безопасности установите переключатели на стене передней панелью наружу.

**警告** 为符合安全规章，请将切换开关安装在墙上，前面板朝上。

**警告** 安全既定に準拠するために、フロントパネルを上向きにしてスイッチを壁にマウントします。

# Redundant Power Supply Connection Warning

**Warning**

If a redundant power system (RPS) is not connected to the switch, install an RPS connector cover on the back of the switch.

**Waarschuwing**

Als er geen redundant voedingssysteem (RPS) aan de schakelaar is gekoppeld, dient u een RPS-connector kapje op de achterkant van de schakelaar te installeren.

**Varoitus**

Jos korvautuvaa tehojärjestelmää (redundant power system, RPS) ei ole liitetty kytkimeen, kiinnitä RPS-liittimen suojuus kytkimen takapuolelle.

**Attention**

Si un système d'alimentation électrique redondant (RPS) n'est pas connecté au commutateur, installez un cache de connecteur RPS à l'arrière du commutateur.

**Warnung**

Wenn keine redundante Stromversorgung (RSV) an den Schalter angeschlossen ist, eine RSV-Steckerabdeckung an der Rückseite des Schalters anbringen.

**Figyelem!**

Ha a kapcsolóhoz nem csatlakozik redundáns tápegység (RPS), az RPS csatlakozófedelét a kapcsoló hátuljára szerelje fel.

**Avvertenza**

Se un sistema RPS (Redundant Power System ) di alimentazione ridondante non è collegato al dispositivo switch, installare un copri-connettore RPS sul retro del switch.

**Advarsel**

Dersom et redundant strømsystem ( Redundant Power System -RPS) ikke er koblet til bryteren, skal det installeres et RPS-koblingsdeksel på baksiden av bryteren.

**Aviso**

Se um sistema de alimentação redundante (RPS) não estiver conectado a um switch, instale uma capa de conector RPS na parte de trás do switch.

**¡Advertencia!**

Si no se conecta un sistema de potencia redundante (RPS) al interruptor, instale una cubierta de conector RPS en la parte posterior del interruptor.

## Installation Warning

**Varning!** Om ett redundant strömförsörjningssystem (redundant power system, RPS) inte finns anslutet till omkopplaren skall ett RPS-kontaktsskydd installeras på baksidan av omkopplaren.

**Предупреждение** Если система питания с избыточными источниками и распределением нагрузки (RPS) не подсоединена к переключателю, установите крышку соединителя RPS на задней стенке переключателя.

**警告** 如果冗余电源系统 (RPS) 未连接切换开关，请在开关后面安装 RPS 接头盖。

**警告** Redundant Power System (RPS) がスイッチに接続されていない場合、スイッチの後ろの部分に RPS コネクタ カバーを設置してください。

# Installation Warning



**Warning**

Only trained and qualified personnel should be allowed to install, replace, or service this equipment.

**Waarschuwing**

Deze apparatuur mag alleen worden geïnstalleerd, vervangen of hersteld door bevoegd geschoold personeel.

**Varoitus**

Tämän laitteen saa asentaa, vaihtaa tai huoltaa ainoastaan koulutettu ja laitteen tunteva henkilökunta.

**Attention**

Il est vivement recommandé de confier l'installation, le remplacement et la maintenance de ces équipements à des personnels qualifiés et expérimentés.

**Warnung**

Das Installieren, Ersetzen oder Bedienen dieser Ausrüstung sollte nur geschultem, qualifiziertem Personal gestattet werden.



<b>Figyelem!</b>	<b>A berendezést csak szakképzett személyek helyezhetik üzembe, cserélhetik és tarthatják karban.</b>
<b>Avvertenza</b>	<b>Questo apparato può essere installato, sostituito o mantenuto unicamente da un personale competente.</b>
<b>Advarsel</b>	<b>Bare opplært og kvalifisert personell skal foreta installasjoner, utskiftninger eller service på dette utstyret.</b>
<b>Aviso</b>	<b>Apenas pessoal treinado e qualificado deve ser autorizado a instalar, substituir ou fazer a revisão deste equipamento.</b>
<b>¡Advertencia!</b>	<b>Solamente el personal calificado debe instalar, reemplazar o utilizar este equipo.</b>
<b>Varning!</b>	<b>Endast utbildad och kvalificerad personal bör få tillåtelse att installera, byta ut eller reparera denna utrustning.</b>
<b>Предупреждение</b>	<b>Установку, замену и обслуживание этого оборудования может осуществлять только специально обученный квалифицированный персонал.</b>
<b>警告</b>	<b>只有经过培训且具有资格的人员才能进行此设备的安装、更换和维修。</b>
<b>警告</b>	<b>この装置の設置、交換、保守は、訓練を受けた対応の資格のある人が行ってください。</b>

## Class 1 Laser Product Warning



Warning

Class 1 laser product.

Waarschuwing

Klasse-1 laser produkt.

■ Class 1 Laser Product Warning

**Varoitus** Luokan 1 lasertuote.

**Attention** Produit laser de classe 1.

**Warnung** Laserprodukt der Klasse 1.

**Figyelem!** Class 1 besorolású lézeres termék.

**Avvertenza** Prodotto laser di Classe 1.

**Advarsel** Laserprodukt av Klasse 1.

**Aviso** Produto laser de classe 1.

**¡Advertencia!** Producto láser Clase I.

**Varning!** Laserprodukt av klass 1.

**Предупреждение** Лазерное устройство класса 1.

**警告** 这是 1 类激光产品。

**警告** クラス1レーザー製品です。

**주의** 1급 레이저 제품.

# Laser Beam Exposure Warning



**Warning** Avoid direct exposure to the laser beam.

**Waarschuwing** Voorkom rechtstreekse blootstelling aan de laserstraal.

**Varoitus** Vältä säteelle altistumista.

**Attention** Éviter toute exposition directe au faisceau.

**Warnung** Schützen Sie sich vor direkter Laserbestrahlung.

**Figyelem!** Kerülje a lézersugárral való közvetlen érintkezést!

**Avvertenza** Evitare l'esposizione diretta al raggio laser.

**Advarsel** Unngå direkte eksponering til laserstrålen.

**Aviso** Evite exposição a raios laser.

**¡Advertencia!** Evite la exposición directa al haz del láser.

**Varning!** Utsätt dig inte för laserstrålning.

**Предупреждение** Избегайте прямого воздействия лазерного луча.

**警告** 注意避免遭受激光光束的直接辐射。

**警告** レーザー光線を直接浴びないように注意してください。

# Laser Radiation Warning



## Warning

Invisible laser radiation may be emitted from disconnected fibers or connectors. Do not stare into beams or view directly with optical instruments.

## Waarschuwing

Losgekoppelde of losgeraakte glasvezels of aansluitingen kunnen onzichtbare laserstraling produceren. Kijk niet rechtstreeks in de straling en gebruik geen optische instrumenten rond deze glasvezels of aansluitingen.

## Varoitus

Irrotetuista kuiduista tai liittimistä voi tulla näkymätöntä lasersäteilyä. Älä tuijota säteitä tai katso niitä suoraan optisilla välineillä.

## Attention

Les fibres ou connecteurs débranchés risquent d'émettre des rayonnements laser invisibles à l'œil. Ne regardez jamais directement les faisceaux laser à l'œil nu, ni d'ailleurs avec des instruments optiques.

## Warnung

Unterbrochene Fasern oder Steckerverbindungen können unsichtbare Laserstrahlung abgeben. Blicken Sie weder mit bloßem Auge noch mit optischen Instrumenten direkt in Laserstrahlen.

## Figyelem!

A nem csatlakoztatott üvegszálak és csatlakozók láthatatlan lézersugárzást bocsáthatnak ki. Ne nézzen bele a sugárba, és ne nézze közvetlenül, optikai berendezések segítségével!

## Avvertenza

Le fibre ottiche ed i relativi connettori possono emettere radiazioni laser. I fasci di luce non devono mai essere osservati direttamente o attraverso strumenti ottici.

## Advarsel

Det kan forekomme usynlig laserstråling fra fiber eller kontakter som er frakoblet. Stirr ikke direkte inn i strålene eller se på dem direkte gjennom et optisk instrument.

## Aviso

Radiação laser invisível pode ser emitida de conectores ou fibras desconectadas. Não olhe diretamente para os feixes ou com instrumentos ópticos.

- ¡Advertencia!** Es posible que las fibras desconectadas emitan radiación láser invisible. No fije la vista en los rayos ni examine éstos con instrumentos ópticos.
- Varning!** Osynlig laserstrålning kan avges från frånkopplade fibrer eller kontaktdon. Rikta inte blicken in i strålar och titta aldrig direkt på dem med hjälp av optiska instrument.
- Предупреждение** Отключенные световоды и разъемы могут испускать невидимое лазерное излучение. Не допускайте попадания лазерного луча в глаза и не смотрите на него через оптические приборы.
- 警告** 断开的光纤或接头有可能发出不可见的激光辐射。请勿直视光束或直接用光学仪器观看光束。
- 警告** 光ファイバ ケーブルまたはコネクタを取り外した状態では、目に見えないレーザー光が放射されていることがあります。光線をのぞきこんだり、光学機器を使用して光線を直接見たりしないでください。

## Catalyst 2950G-24-EI-DC Service Requirement



### Warning

The Catalyst 2950G-24-EI-DC contains no field-replaceable units (FRUs). Do not open the chassis or attempt to remove or replace any components. For information about obtaining service for this unit, contact your reseller or Cisco sales representative.

### Waarschuwing

De Catalyst 2950G-24-EI-DC bevat geen FRU's (field-replaceable units ofwel veldvervangbare eenheden). Open het chassis niet en probeer geen onderdelen te verwijderen of te vervangen. Voor informatie omtrent het onderhoud voor deze eenheid dient u contact op te nemen met uw doorverkoper of verkoopvertegenwoordiger van Cisco.

- Varoitus** Catalyst 2950G-24-EI-DC ei sisällä kenttäkorjattavia laitteita. Runkoa ei saa avata, eikä osia saa yrittää poistaa tai korjata. Laitteen huoltoa koskevia tietoja saa jälleenmyyjältä tai Ciscon myyntiedustajalta.
- Attention** Le Catalyst 2950G-24-EI-DC ne dispose pas d'unités remplaçables sur site (FRU). Il est recommandé de ne pas ouvrir le châssis ni de retirer ou remplacer des composants. Pour plus de détails sur la maintenance de cette unité, contactez votre revendeur ou votre ingénieur commercial Cisco.
- Warnung** Der Catalyst 2950G-24-EI-DC enthält keine vor Ort austauschbaren Einheiten (FRUs). Das Gehäuse nicht öffnen und Komponenten nicht entfernen oder ersetzen. Serviceinformationen zu dieser Einheit erhalten Sie von Ihrem Wiederverkäufer oder von Ihrem Cisco-Vertreter.
- Figyelem!** A Catalyst 2950G-24-EI-DC készülék nem tartalmaz helyszínen cserélhető részegységeket. Ne nyissa fel a házat, és ne próbálja meg eltávolítani vagy kicserélni semelyik alkatrészt. A készülékhez igénybe vehető karbantartási szolgáltatásokról viszonteladójától vagy Cisco értékesítési képviselőjétől kérhet információt.
- Avvertenza** Catalyst 2950G-24-EI-DC non ha componenti sostituibili sul posto (FRU). Non aprite lo chassis o tentate di rimuovere o sostituire componenti. Per maggiori informazioni sui servizi di assistenza per questo dispositivo, contattate il vostro rivenditore Cisco.
- Advarsel** Catalyst 2950G-24-EI-DC inneholder ingen kunde-utskiftbare deler (FRU-deler). Gjør ikke forsøk på å åpne kabinetet eller fjerne eller skifte ut noen av komponentene. Ta kontakt med forhandleren eller en Cisco-salgsrepresentant for informasjon om hvor det kan utføres service på enheten.
- Aviso** O interruptor Catalisador 2950G-24-EI-DC não contém nenhuma unidade substituível em campo. Não abrir o chassis ou tentar remover ou substituir quaisquer componentes. Para mais informações sobre a manutenção desta unidade, contactar o seu revendedor ou um representante de vendas da Cisco.

- ¡Advertencia!** El Catalyst 2950G-24-EI-DC no contiene componentes reemplazables en las instalaciones (Field-Replaceable Units, FRU). No abra el chasis ni intente reemplazar componentes. Para más información sobre cómo reparar este aparato, póngase en contacto con su distribuidor o representante de Cisco.
- Varning!** Catalyst 2950G-24-EI-DC innehåller inte några enheter som kan bytas ut på fältet. Öppna inte chassit och försök inte heller att ta bort eller byta ut några delar. Kontakta återförsäljaren eller representanten för Cisco om du behöver information om service av enheten.
- Предупреждение** Устройство Catalyst 2950G-24-EI-DC не содержит деталей, заменяемых в процессе эксплуатации. Не открывайте устройство и не пытайтесь снимать или заменять какие-либо компоненты. Для получения сведений об обслуживании этих частей обратитесь к продавцу или торговому представителю Cisco.
- 警告** Catalyst 2950G-24-EI-DC 不包含任何现场可替换的部件 (FRU)。请勿打开底盘或试图取出或替换任何部件。如果需要有关如何获得此部件维修的信息，请与再销商或 Cisco 的销售代表联系。
- 警告** Catalyst 2950G-24-EI-DC には Field-Replaceable Units (FRU) は含まれていません。シャーシを開けたり、コンポーネントをはずしたり交換したりしないでください。このユニットのサービスについてのお問い合わせは、再販業者または Cisco の営業担当者までどうぞ。
-

# Catalyst 2950ST-24 LRE 997 Service Requirement



## Warning

The Catalyst 2950ST-24 LRE 997 contains no field-replaceable units (FRUs). Do not open the chassis or attempt to remove or replace any components. For information about obtaining service for this unit, contact your reseller or Cisco sales representative.

## Waarschuwing

De Catalyst 2950ST-24 LRE 997 bevat geen FRU's (field-replaceable units ofwel veldvervangbare eenheden). Open het chassis niet en probeer geen onderdelen te verwijderen of te vervangen. Voor informatie omtrent het onderhoud voor deze eenheid dient u contact op te nemen met uw doorverkoper of verkoopvertegenwoordiger van Cisco.

## Varoitus

Catalyst 2950ST-24 LRE 997 ei sisällä kenttäkorjattavia laitteita. Runkoa ei saa avata, eikä osia saa yrittää poistaa tai korjata. Laitteen huoltoa koskevia tietoja saa jälleenmyyjältä tai Ciscon myyntiedustajalta.

## Attention

Le Catalyst 2950ST-24 LRE 997 ne dispose pas d'unités remplaçables sur site (FRU). Il est recommandé de ne pas ouvrir le châssis ni de retirer ou remplacer des composants. Pour plus de détails sur la maintenance de cette unité, contactez votre revendeur ou votre ingénieur commercial Cisco.

## Warnung

Der Catalyst 2950ST-24 LRE 997 enthält keine vor Ort austauschbaren Einheiten (FRUs). Das Gehäuse nicht öffnen und Komponenten nicht entfernen oder ersetzen. Serviceinformationen zu dieser Einheit erhalten Sie von Ihrem Wiederverkäufer oder von Ihrem Cisco-Vertreter.

## Figyelem!

A Catalyst 2950ST-24 LRE 997 készülék nem tartalmaz helyszínen cserélhető részegységeket. Ne nyissa fel a házat, és ne próbálja meg eltávolítani vagy kicserélni semelyik alkatrészt. A készülékhez igénybe vehető karbantartási szolgáltatásokról viszonteladójától vagy Cisco értékesítési képviselőjétől kérhet információt.



Avvertenza	Catalyst 2950ST-24 LRE 997 non ha componenti sostituibili sul posto (FRU). Non aprite lo chassis o tentate di rimuovere o sostituire componenti. Per maggiori informazioni sui servizi di assistenza per questo dispositivo, contattate il vostro rivenditore Cisco.
Advarsel	Catalyst 2950ST-24 LRE 997 inneholder ingen kunde-utskiftbare deler (FRU-deler). Gjør ikke forsøk på å åpne kabinettet eller fjerne eller skifte ut noen av komponentene. Ta kontakt med forhandleren eller en Cisco-salgsrepresentant for informasjon om hvor det kan utføres service på enheten.
Aviso	O interruptor Catalisador 2950ST-24 LRE 997 não contém nenhuma unidade substituível em campo. Não abrir o chassis ou tentar remover ou substituir quaisquer componentes. Para mais informações sobre a manutenção desta unidade, contactar o seu revendedor ou um representante de vendas da Cisco.
¡Advertencia!	El Catalyst 2950ST-24 LRE 997 no contiene componentes reemplazables en las instalaciones (Field-Replaceable Units, FRU). No abra el chasis ni intente reemplazar componentes. Para más información sobre cómo reparar este aparato, póngase en contacto con su distribuidor o representante de Cisco.
Varning!	Catalyst 2950ST-24 LRE 997 innehåller inte några enheter som kan bytas ut på fältet. Öppna inte chassit och försök inte heller att ta bort eller byta ut några delar. Kontakta återförsäljaren eller representanten för Cisco om du behöver information om service av enheten.
Предупреждение	Устройство Catalyst 2950ST-24 LRE 997 не содержит деталей, заменяемых в процессе эксплуатации. Не открывайте устройство и не пытайтесь снимать или заменять какие-либо компоненты. Для получения сведений об обслуживании этих частей обратитесь к продавцу или торговому представителю Cisco.

## Restricted Area Warning

**警告** Catalyst 2950ST-24 LRE 997 不包含任何现场可替换的部件 (FRU)。请勿打开底盘或试图取出或替换任何部件。如果需要有关如何获得此部件维修的信息，请与再销商或 Cisco 的销售代表联系。

**警告** Catalyst 2950ST-24 LRE 997 には Field-Replaceable Units (FRU) は含まれていません。シャーシを開けたり、コンポーネントをはずしたり交換したりしないでください。このユニットのサービスについてのお問い合わせは、再販業者または Cisco の営業担当者までどうぞ。

# Restricted Area Warning



## Warning

This unit is intended for installation in restricted access areas. A restricted access area can be accessed only through the use of a special tool, lock and key, or other means of security.

## Waarschuwing

Deze eenheid is bestemd voor installatie in plaatsen met beperkte toegang. Toegang tot een dergelijke plaats kan alleen verkregen worden door middel van een speciaal instrument, een slot en sleutel of een ander veiligheidsmiddel.

## Varoitus

Tämä laite on tarkoitettu asennettavaksi paikkaan, johon pääsy on rajoitettua. Tällaiseen paikkaan pääsee vain erikoistyökalua, lukkoon sopivaa avainta tai jotakin muuta turvalaitetta käyttämällä.

## Attention

Cet appareil est à installer dans des zones d'accès réservé. L'accès à une zone d'accès réservé n'est possible qu'en utilisant un outil spécial, un mécanisme de verrouillage et une clé, ou tout autre moyen de sécurité.

## Warnung

Diese Einheit ist zur Installation in Bereichen mit beschränktem Zutritt vorgesehen. Der Zutritt zu derartigen Bereichen ist nur mit einem Spezialwerkzeug, Schloss und Schlüssel oder einer sonstigen Sicherheitsvorkehrung möglich.

<b>Figyelem!</b>	<b>A készülék korlátozottan hozzáférhető területre történő beszerelésre készült. A korlátozottan hozzáférhető területekhez csak speciális szerszám, zár és kulcs vagy más biztonsági berendezés segítségével lehet hozzáférni.</b>
<b>Avvertenza</b>	<b>Questa unità è prevista per essere installata in un'area ad accesso limitato, vale a dire un'area accessibile solo mediante l'uso di un attrezzo speciale, come lucchetto e chiave, o altri dispositivi di sicurezza.</b>
<b>Advarsel</b>	<b>Denne enheten er beregnet på installasjon i områder med begrenset tilgang. Et begrenset tilgangsområde kan bare nås ved hjelp av et spesielt verktøy, lås og nøkkel, eller andre sikkerhetsanordninger.</b>
<b>Aviso</b>	<b>Esta unidade foi concebida para instalação em áreas de acesso restrito. Uma área de acesso restrito é uma área à qual apenas tem acesso o pessoal de serviço autorizado, que possua uma ferramenta, chave e fechadura especial, ou qualquer outra forma de segurança.</b>
<b>¡Advertencia!</b>	<b>Esta unidad ha sido diseñada para instalación en áreas de acceso restringido. Sólo puede obtenerse acceso a una de estas áreas mediante la utilización de una herramienta especial, cerradura con llave u otro medio de seguridad.</b>
<b>Varning!</b>	<b>Denna enhet är avsedd för installation i områden med begränsat tillträde. Ett område med begränsat tillträde kan endast tillträdas med hjälp av specialverktyg, lås och nyckel eller annan säkerhetsanordning.</b>
<b>Предупреждение</b>	<b>Данное устройство предназначено для установки в помещениях с ограниченным доступом. В такие помещения можно попасть, только имея специальное устройство доступа, карту или ключ или пройдя проверку другими средствами обеспечения безопасности.</b>
<b>警告</b>	<b>此部件应安装在限制进出的场所。限制进出的场所指只能通过使用特殊工具、锁和钥匙或其它安全手段进出的场所。</b>
<b>警告</b>	<b>この装置は立ち入り制限区域内に設置することが前提になっています。立ち入り制限区域とは、鍵、錠、またはその他の保全手段を使用しないと立ち入ることができない区域です。</b>

# Ethernet Cable Shielding in Offices



**Warning**

Ethernet cables must be shielded when used in a central office environment.

**Waarschuwing**

Ethernetkabels dienen beveiligd te worden als ze in een centrale kantooromgeving worden gebruikt.

**Varoitus**

Ethernet-kaapelit täytyy suojata, kun niitä käytetään yleisessä toimistoympäristössä.

**Attention**

Pour une utilisation en site central, les câbles Ethernet doivent être impérativement blindés.

**Warnung**

Ethernet-Kabel müssen abgeschirmt werden, wenn sie in einer Zentrale eingesetzt werden.

**Figyelem!**

Az Ethernet kábeleket árnyékolással kell ellátni, ha azokat helyi központban használják.

**Avvertenza**

I cavi Ethernet devono essere schermati se utilizzati in un ambiente di ufficio centrale.

**Advarsel**

Ethernet-kabler skal være skjermet når de brukes i et sentralt kontormiljø.

**Aviso**

Os cabos "Ethernet" deverão estar armados quando usados em ambiente de escritório central.

**¡Advertencia!**

Los cables Ethernet deben estar protegidos cuando se usen dentro de una oficina central.

**Varning!**

Ethernetkablar måste vara avskärmade vid användning i central kontorsmiljö.

**Предупреждение**

Необходимо экранировать кабели Ethernet, используемые в офисе.

**警告** 在中心局环境中使用以太网电缆时，必须加以屏蔽。

**警告** 中央オフィス環境で使用される場合、イーサネットケーブルは遮蔽される必要があります。

## Chassis Power Connection



### Warning

Before connecting or disconnecting ground or power wires to the chassis, ensure that power is removed from the DC circuit. To ensure that all power is OFF, locate the circuit breaker on the panel board that services the DC circuit, switch the circuit breaker to the OFF position, and tape the switch handle of the circuit breaker in the OFF position.

### Waarschuwing

Voordat u aarddraden of elektriciteitsdraden op het frame aansluit of van het frame neemt, dient u te controleren of de stroom naar het gelijkstroomcircuit uitgeschakeld is. Om u ervan te verzekeren dat alle stroom UIT is geschakeld, kiest u op het schakelbord de stroomverbreker die het gelijkstroomcircuit bedient, draait de stroomverbreker naar de UIT positie en plakt de schakelaarhendel van de stroomverbreker met plakband in de UIT positie vast.

### Varoitus

Varmista, että tasavirtapiirissä ei ole virtaa ennen maadoitus- tai virtajohtojen kytkemistä asennuspohjaan tai ennen niiden irrottamista. Varmistaaksesi, että virta on KATKAISTU täysin, paikanna tasavirrasta huolehtivassa kojetaulussa sijaitseva suojakytkin, käännä suojakytkin KATKAISTU-asentoon ja teippaa suojakytkimen varsi niin, että se pysyy KATKAISTU-asennossa.

### Attention

Avant de connecter ou de déconnecter les câbles d'alimentation (pôles et terre) du châssis, vérifiez que le circuit de courant continu est hors tension : localisez le disjoncteur sur le panneau de commande du circuit de courant continu, poussez-le sur la position fermée (OFF) et, à l'aide d'un ruban adhésif, bloquez sa poignée sur cette position.

- Warnung** Gleichstrom-Unterbrechung Bevor Sie Erdungs- oder Stromkabel an das Chassis anschließen oder von ihm abtrennen, ist sicherzustellen, daß der Gleichstrom-Stromkreis unterbrochen ist. Um sicherzustellen, daß sämtlicher Strom AUS ist, machen Sie auf der Schalttafel den Unterbrecher für die Gleichstromschaltung ausfindig, stellen Sie den Unterbrecher auf OFF, und kleben Sie den Schaltergriff des Unterbrechers mit Klebeband in der AUS-Stellung fest.
- Figyelem!** Mielőtt a föld- vagy a fázisvezetéket a házhoz csatlakoztatja, feltétlenül szakítsa meg az egyenáramú áramkör tápellátását. Úgy gondoskodhat arról, hogy mindenféle tápellátás meg legyen szakítva, hogy megkeresi az árammegszakítót az egyenáramú áramkört kiszolgáló kártyán, az árammegszakítót OFF (KI) helyzetbe állítja, és árammegszakító kapcsolóját az OFF (KI) helyzetben leragasztja.
- Avvertenza** Prima di collegare o distaccare i cavi elettrici o di messa a terra dallo chassis, assicuratevi che il circuito DC non sia alimentato. Per verificare che tutta l'alimentazione sia scollegata (OFF), individuare l'interruttore automatico sul quadro strumenti che alimenta il circuito CC, mettere l'interruttore in posizione OFF e fissarlo con nastro adesivo in tale posizione.
- Advarsel** Før til- eller frakobling av jord- og strømledninger til kabinettet, kontroller at strømmen er frakoblet likestrømkretsen. Sørg for at all strøm er slått AV. Dette gjøres ved å lokalisere strømbryteren på brytertavlen som betjener likestrømkretsen, slå strømbryteren AV og teipe bryterhåndtaket på strømbryteren i AV-stilling.
- Aviso** Antes de conectar ou desconectar a ligação à terra ou a alimentação do chassis, certifique-se de que desligou a fonte de alimentação de energia do circuito de corrente contínua. Para se assegurar que toda a corrente foi DESLIGADA, localize o disjuntor no painel que serve o circuito de corrente contínua e coloque-o na posição OFF (Desligado), segurando nessa posição a manivela do interruptor do disjuntor com fita isoladora.

**¡Advertencia!** Antes de conectar o desconectar el circuito de tierra o de alimentación del chasis, asegúrese que la alimentación del circuito CC esté cortada (OFF). Para asegurarse de que toda la alimentación esté cortada (OFF), localice el interruptor automático en el panel que alimenta el circuito de corriente continua, cambie el interruptor automático a la posición de apagado (OFF) y sujete con cinta la palanca del interruptor automático en posición de apagado (OFF).

**Varning!** Innan du kopplar jord- eller elledningar till eller från chassit måste du kontrollera att strömförsörjningen till likströmskretsen är bruten. Kontrollera att all strömförsörjning är BRUTEN genom att slå AV det överspänningskydd som skyddar likströmskretsen och tejpa fast överspänningskyddets omkopplare i FRÅN-läget.

**Предупреждение** Перед подключением к шасси проводов заземления или питания необходимо убедиться в том, что питание в цепи постоянного тока отключено. Чтобы убедиться в том, что питание полностью ОТКЛЮЧЕНО, найдите на панели выключатель цепи постоянного тока, установите его в

**警告** 将接地线或电源线连接到底盘或从底盘上断开前，应确保电源已与直流电路断开。为了确保所有电源均处于“关闭”状态，须找到控制直流电路面板上的断路器，将断路器切换到“关闭”位置，并用胶带将断路器的开关手柄固定在“关闭”位置上。

**警告** シャーシヘアース端子または電源コードを接続したり、切断したりする場合、DC回路から電源がはずれていることを確認してください。すべての電源がオフになっていることを確認する際は、DC回路をサポートするパネルボード上に回路ブレーカを設置し、回路ブレーカのスイッチをオフにし、回路ブレーカのスイッチハンドルをオフの位置に接着します。

# Exposed DC Power Wire Warning



## Warning

An exposed wire lead from a DC-input power source can conduct harmful levels of electricity. Be sure that no exposed portion of the DC-input power source wire extends from the terminal block plug.

## Waarschuwing

Een blootgestelde verbindingsdraad van een ingangsgelijkstroombron kan gevaarlijke elektriciteitsniveaus geleiden. Zorg ervoor dat geen blootgesteld deel van het draad van de ingangsgelijkstroombron zich uitstrekt vanuit het aansluitblok van de terminal.

## Varoitus

Tasavirtalähteestä tuleva avoin johto voi johtaa vaarallisen määrän sähköä. Varmista, ettei kaapelikengän pistokkeesta tule esille lainkaan tasavirtajohdon avointa osaa.

## Attention

Pour éviter tout risque de choc électrique, vérifiez que les câbles d'alimentation secteur sont protégés par une gaine. Aucun fil dénudé ne doit apparaître hors du bloc d'alimentation du terminal.

## Warnung

Eine ungeschützte Kabelleitung von einer Gleichstrom-Eingangsspannungsquelle kann schädliche Elektrizitätslevel führen. Achten Sie darauf, daß von dem Klemmleistenstecker aus kein ungeschütztes Eingangsgleichstromkabel freiliegt.

## Figyelem!

Az egyenáramú tápegység egyik hozzáférhető vezetéke veszélyes áramerősségű lehet. Győződjön meg róla, hogy az egyenáramú tápegység egyik vezetéke sem lóg ki a sorkapocsból.

## Avvertenza

Un cavo elettrico scoperto proveniente da un alimentatore DC-INPUT può trasmettere scariche elettriche ad elevata tensione. Assicuratevi che i cavi in uscita dall'alimentatore DC-input non presentino punti scoperti.

## Advarsel

En avdekket ledning fra en likestrømskilde kan lede farlig elektrisitet. Kontroller at ingen avdekkede deler av ledningen til likestrømskilden stikker ut av terminalens koblingsblokk.



<b>Aviso</b>	<b>Um fio condutor exposto de uma unidade de entrada de DC (corrente contínua) pode transportar níveis perigosos de electricidade. Certifique-se de que nenhuma secção exposta de um fio condutor da fonte de energia de entrada de DC se estende a partir da ficha da placa de terminais.</b>
<b>¡Advertencia!</b>	<b>Un cable desnudo de una fuente de entrada de alimentación de corriente directa (DC) puede conducir niveles de electricidad peligrosos. Asegúrese de que ninguna parte del cable de la fuente de alimentación de DC de entrada sale del enchufe del bloque de terminal.</b>
<b>Varning!</b>	<b>En blottad trådlledning från en likströmsförsörjningsenhet kan utgöra en ledare för skadliga elektricitetsnivåer. Se till att inte någon blottad ledningsdel från likströmsförsörjningsenheten sticker ut från stiftplinten.</b>
<b>Предупреждение</b>	<b>Неизолированный провод, который выходит из источника питания постоянного тока, может нести опасный уровень заряда. Убедитесь, что провод входного источника питания постоянного тока, который выходит из вилки контактной колодки, надежно изолирован.</b>
<b>警告</b>	<b>从 DC 输入电源裸露的引线可能会造成电击伤害。请确保 DC 输入电源线没有任何裸露部份从端子板插头伸展出来。</b>
<b>警告</b>	<b>DC 入力電源装置からの露出したリード線は、危険な電気を伝導することがあります。DC 入力電源装置からの配線の露出部分が、端子ブロックのプラグからはみ出していないかどうかを確認してください。</b>

# Service Personnel Warning



## Warning

This equipment is to be installed and maintained by service personnel only as defined by AS/NZS 3260 Clause 1.2.14.3 Service Personnel.

## Waarschuwing

Deze apparatuur mag slechts geïnstalleerd en onderhouden worden door servicepersoneel conform de definitie van AS/NZS 3260 Clausule 1.2.14.3 Service Personnel.

## Varoitus

Tämän laitteen saa asentaa tai huoltaa ainoastaan Australiassa ja Uudessa Seelannissa sovellettavan AS/NZS 3260 -standardin kohdan 1.2.14.3 Service Personnel määrittelemä huoltohenkilöstö.

## Attention

Cet équipement ne doit être installé et entretenu que par du personnel d'entretien comme défini par la réglementation AS/NZS 3260 Clause 1.2.14.3 Service Personnel.

## Warnung

Dieses Gerät darf nur von Wartungspersonal gemäß AS/NZS-Definition 3260, Paragraph 1.2.14.3, "Service Personnel", installiert und gewartet werden.

## Figyelem!

A készüléket az AS/NZS 3260 előírás „1.2.14.3 Service Personnel” pontja értelmében csak hozzáértő szakemberek helyezhetik üzembe és tarthatják karban.

## Avvertenza

Questo apparecchio deve essere installato e mantenuto in efficienza esclusivamente da personale tecnico che soddisfi i requisiti specificati nella sezione 1.2.14.3 sul 'Service Personnel' contenuta nelle norme AS/NZS 3260.

## Advarsel

Installasjon og vedlikehold av dette utstyret skal kun foretas av vedlikeholdspersonell som definert i AS/NZS 3260, klausul 1.2.14.3 Service Personnel.

## Aviso

Este equipamento deverá ser instalado e reparado apenas por pessoal de manutenção qualificado, conforme estipulado em AS/NZS 3260 Cláusula 1.2.14.3 Service Personnel.

**¡Advertencia!** Este equipo se debe instalar y mantener solamente por personal de servicio, según definido por AS/NZS 3260 Cláusula 1.2.14.3 Service Personnel.

**Varning!** Installation och underhåll av denna utrustning får endast utföras av servicepersonal enligt definition i AS/NZS 3260 klausul 1.2.14.3 Service Personnel.

**Предупреждение** Данное оборудование должно устанавливаться и обслуживаться квалифицированным персоналом в соответствии с пунктом 1.2.14.3 «Обслуживающий персонал» стандарта AS/NZS 3260.

**警告** 此设备应该仅由按 AS/NZS 3260 条款 1.2.14.3 “维修人员” 一节所规定的维修人员来进行安装和维护。

**警告** この装置の設置およびメンテナンス作業は、AS/NZS 3260 の 1.2.14.3 条に定義されているサービス要員が行う必要があります。

---

■ Service Personnel Warning



---

## Numerics

### 10/100/1000 ports

- cable lengths [3-7](#)
- connecting to [3-32 to 3-36](#)
- connectors and cables [B-3 to B-4](#)
- described [2-10 to 2-11](#)
- illustrated [2-8, 2-9](#)

### 10/100 ports

- cable lengths [3-7](#)
- connecting to [3-32 to 3-36](#)
- connectors and cables [B-2](#)
- described [2-9 to 2-10](#)
- illustrated [2-5](#)

### 1000BASE-SX ports

- cable lengths [3-7](#)
- connecting to [3-36 to 3-38](#)
- connectors and cables [B-6](#)
- described [2-11](#)
- illustrated [2-9](#)
- power levels, fiber-optic [A-7](#)

### 1000BASE-T GBIC modules

- cable lengths [3-7](#)
- connecting to [3-47 to 3-48](#)
- connectors [B-7](#)
- described [2-13](#)
- illustrated [3-27](#)
- installing [3-26](#)

### 1000BASE-X GBIC modules

- cable lengths [3-7](#)
- connecting to [3-45 to 3-46](#)
- connectors [B-6](#)
- described [2-13](#)
- illustrated [3-26](#)
- installing [3-26](#)

### 100BASE-FX ports

- cable lengths [3-7](#)
- connecting to [3-36 to 3-38](#)
- connectors and cables [B-6](#)
- described [2-11](#)
- illustrated [2-5](#)
- power levels, fiber-optic [A-7](#)

- 
- ## A
- AC power
    - connector [2-29](#)
    - specifications [A-2 to A-3](#)
  - adapter pinouts, terminal
    - RJ-45-to-DB-25 [B-16](#)
    - RJ-45-to-DB-9 [B-15](#)
  - addresses, assigning IP [3-50](#)
  - agency approvals [A-7, A-8, A-9](#)
  - altitude [A-2 to A-4](#)
  - autonegotiation
    - 10/100/1000 ports [2-11](#)
    - 10/100 ports [2-10](#)
- 
- ## B
- bandwidth utilization [2-23 to 2-27](#)
  - brackets
    - See mounting brackets, attaching
- 
- ## C
- cable guide, attaching [3-22](#)
  - cables
    - 10/100/1000 ports [2-10 to 2-11](#)
    - 10/100 ports [2-9 to 2-10](#)
  - cables (continued)
    - crossover
      - connecting to [B-2, B-4](#)
      - four twisted-pair pinout, 10/100 ports [B-10](#)
      - four twisted-pair pinout, 1000BASE-T ports [B-11](#)
      - two twisted-pair pinout [B-9](#)
    - GBIC
      - 1000BASE-T module [3-47](#)
      - 1000BASE-X module [3-45](#)
      - CWDM module [3-44](#)
      - GigaStack module [3-48](#)
    - problems, solving [4-3 to 4-4](#)
    - RJ-21 pinouts [B-11, B-13](#)
    - rollover [B-14](#)
    - straight-through
      - connecting to [B-2, B-4](#)
      - four twisted-pair pinout, 10/100 ports [B-9](#)
      - four twisted-pair pinout, 1000BASE-T ports [B-10](#)
      - two twisted-pair pinout [B-8](#)
    - twisted-pair
      - 10/100/1000 ports [2-10 to 2-11](#)
      - 10/100 ports [2-9 to 2-10](#)
      - See also connectors and cables
  - Catalyst 2950G-24-EI-DC service warning [C-1, D-31 to D-33](#)
  - Catalyst 2950ST-24 LRE 997 service warning [C-1, D-34 to D-36](#)

- cautions, defined [xvi](#)
- chassis warnings
  - against stacking [3-3, D-22](#)
  - rack-mounting, servicing [3-10, D-8 to D-12](#)
- Cisco IE2100 [2-33](#)
- Cisco IE2100 Series Configuration Registrar
  - See Cisco IE2100
- Cisco Intelligent Engine 2100
  - See Cisco IE2100
- CiscoView [2-32](#)
- Class 1 laser product warning [3-4, D-27](#)
- clearance [3-7](#)
- CLI [2-32](#)
- Cluster Builder application [2-32](#)
- Cluster Management Suite
  - See CMS
- Cluster Manager application [2-32](#)
- Cluster View application [2-32](#)
- CMS
  - accessing your switch [1-11](#)
  - Cluster Builder [2-32](#)
  - Cluster Management [2-32](#)
  - Cluster View [2-32](#)
  - described [2-32](#)
  - Device Manager [2-32](#)
  - installing Java plug-in [1-13](#)
  - Java plug-in for the Solaris platform [1-15](#)
  - CMS (continued)
    - Java plug-in for the Windows platform [1-15](#)
    - operating systems and browsers supported [1-12](#)
    - recommended platforms for web-based management [1-12](#)
- Coarse Wave Division Multiplexing GBIC modules
  - See CWDM GBIC modules
- command-line interface
  - See CLI
- configuration examples, network [2-1](#)
- configuring ports [3-50](#)
- connecting
  - to 10/100/1000 ports [3-32 to 3-36](#)
  - to 10/100 ports [3-32 to 3-36](#)
  - to 1000BASE-SX ports [3-36 to 3-38](#)
  - to 1000BASE-T GBIC module ports [3-47](#)
  - to 1000BASE-X GBIC module ports [3-45 to 3-46](#)
  - to 100BASE-FX ports [3-36 to 3-38](#)
  - to CWDM GBIC module ports [3-44](#)
  - to DC power [C-1 to C-11](#)
  - to GBIC module ports [3-44 to 3-49](#)
  - to GigaStack GBIC module ports [3-48](#)
  - to LRE ports [3-38 to 3-44](#)
  - to SFP modules [3-49 to 3-50](#)
- connecting to the console port [1-3](#)
- connectivity problems, solving [4-4](#)

## connectors and cables

- 10/100/1000 ports [B-3 to B-4](#)
- 10/100 ports [B-2](#)
- 1000BASE-SX ports [B-6](#)
- 1000BASE-T GBIC module ports [B-7](#)
- 1000BASE-X GBIC module ports [B-6](#)
- 100BASE-FX ports [B-6](#)
- console port [B-8](#)
- GigaStack GBIC module ports [B-7](#)
- power
  - AC [2-29](#)
  - DC [2-30](#)
  - RPS [2-31](#)
- RJ-21 [2-12, B-5](#)
- See also cables

## console port

- cable, rollover [B-14](#)
- connecting to [1-3](#)
- RJ-45-to-DB-25 terminal adapter
  - pinouts [B-16](#)
- RJ-45-to-DB-9 adapter cable pinouts [B-15](#)

## conventions

- command [xvi](#)
- document [xvi](#)

## crossover cable

- connecting to
  - 10/100/1000 ports [3-34](#)
  - 10/100 ports [3-34](#)
  - 1000BASE-T GBIC module ports [3-47](#)
- connectivity problems [4-4](#)
- pinout
  - four twisted-pair, 10/100 ports [B-10](#)
  - four twisted-pair, 1000BASE-T ports [B-11](#)
  - two twisted-pair [B-9](#)
- CWDM GBIC modules
  - cable lengths [3-7](#)
  - connecting to [3-44](#)
  - described [2-13](#)
  - installing [3-26](#)

---

**D**

## DC power

- connecting to [C-1 to C-11](#)
- connector [2-30](#)
- specifications [A-4, A-6](#)
- warnings [C-1, C-2, C-5](#)

DC power disconnection warning [C-5](#)desk-mounting [3-22](#)



Device Manager [2-32](#)

dimensions [A-2 to A-6](#)

documentation

ordering [xxvi](#)

related publications [xxiii to xxv](#)

URLs, Cisco [xxv](#)

document conventions [xvi](#)

duplex LED [2-22, 2-23, 2-24](#)

---

## E

electrical noise, avoiding [3-8](#)

electromagnetic interface (EMI) [A-7, A-8, A-9](#)

EMC

agency approvals [A-7, A-8, A-9](#)

regulatory statements [3-4 to 3-6](#)

EMC regulatory statements [3-4 to 3-6](#)

environmental ranges [A-2 to A-6](#)

Ethernet cable warning [C-1, D-38](#)

examples, network configuration [2-1](#)

exposed DC power wire warning [C-8, D-42](#)

---

## F

fan problems, solving [4-5](#)

features [2-1 to 2-3](#)

feedback to Cisco Systems, web [xxvi](#)

fiber-optic port specifications [A-7](#)

front panel

10/100/1000 ports [2-10 to 2-11](#)

10/100 ports [2-9 to 2-10](#)

1000BASE-SX ports [2-11](#)

100BASE-FX ports [2-11](#)

clearance [3-7](#)

described [2-4](#)

GBIC module ports [2-13 to 2-14](#)

illustrated [2-5 to 2-8](#)

LEDs [2-17 to 2-19](#)

LRE ports [2-12](#)

SFP module ports [2-14 to 2-15](#)

---

## G

GBIC modules

cable lengths [3-7](#)

cables

1000BASE-T [B-4](#)

1000BASE-X [3-45](#)

CWDM [3-44](#)

GigaStack [B-7](#)

connecting to [3-44 to 3-49](#)

connectors

1000BASE-T [B-5](#)

1000BASE-X [B-6](#)

CWDM [3-44](#)

GigaStack [B-7](#)

---

**GBIC modules (continued)**

described [2-13 to 2-14](#)

illustrated

1000BASE-T [3-27](#)

1000BASE-X [3-26](#)

GigaStack [3-27](#)

module slots [2-6 to 2-7](#)

installing [3-26](#)

**Gigabit Interface Converters**

See GBIC modules

**GigaStack GBIC modules**

cable lengths [3-7](#)

connecting to [3-48](#)

connectors and cables [B-7](#)

described [2-13](#)

illustrated [3-27](#)

installing [3-26](#)

ground connection warning [3-3, C-2, D-18](#)

grounded equipment warning [3-3, C-2, D-16](#)

---

**H**

HP OpenView [2-32](#)

humidity [A-2 to A-6](#)

---

**installation**

assigning the IP Address [1-6](#)

cable guide [3-22](#)

connecting to an ethernet port [1-10](#)

connecting to a power source [1-5](#)

connecting to LRE ports [3-38 to 3-44](#)

desk-mount [3-22](#)

guidelines [3-7](#)

mounting on a wall [3-25](#)

package contents [3-8 to 3-36](#)

pre-installation information and  
guidelines [3-2 to 3-6](#)

rack-mount [3-10 to 3-22](#)

shelf-mount [3-22](#)

starting the terminal-emulation software [1-4](#)

table-mount [3-22](#)

wall-mount [3-23 to 3-25](#)

warning [3-2, D-5](#)

installing GBIC modules [3-26 to 3-27](#)

installing SFP modules [3-28 to 3-30](#)

IOS command-line interface

See CLI

IP address procedures [3-50](#)

---

## J

jewelry removal warning [3-3, D-20](#)

---

## L

laser beam exposure warning [3-4, D-29](#)

### LEDs

color meanings [2-22 to 2-23, 2-24](#)

duplex (DUPLX) [2-22, 2-23, 2-24](#)

front panel [2-17 to 2-19](#)

full-duplex [2-23, 2-24](#)

half-duplex [2-23, 2-24](#)

interpreting [2-22 to 2-23](#)

LRE [2-22, 2-24](#)

port [2-22](#)

port mode [2-21 to 2-24](#)

port status [2-22](#)

RPS [2-21](#)

speed (SPEED) [2-22, 2-23, 2-24](#)

status (STAT) [2-22, 2-24](#)

system [2-20](#)

utilization (UTIL) [2-22, 2-23](#)

lightning activity warning [3-4, D-4](#)

Long-Reach Ethernet ports

See LRE ports

### LRE ports

and POTS splitters [3-39](#)

cables, RJ-21 [3-40](#)

connecting to [3-38 to 3-44](#)

connection guidelines [3-38](#)

described [2-12](#)

illustrated [2-7](#)

LEDs [2-22, 2-24](#)

problems, solving [4-6](#)

See also RJ-21 connector

LRE uplink ports [2-11](#)

---

## M

main disconnecting device warning [3-3, D-6](#)

management options [2-32](#)

Mode button [2-21](#)

mounting

desk [3-22](#)

rack [3-10 to 3-22](#)

shelf [3-22](#)

table [3-22](#)

mounting brackets, attaching [3-12 to 3-20, 3-23 to 3-24](#)

MT-RJ connector [B-6](#)

---

## N

network configuration examples [2-1](#)  
noise, electrical [3-8](#)  
no on/off switch warning [3-2, D-14](#)  
notes, defined [xvi](#)

---

## O

obtaining documentation [xxv to xxvii](#)  
overtemperature warning [3-3, D-12](#)

---

## P

package contents [3-8 to 3-36](#)  
patch cables, MT-RJ [2-12](#)  
performance problems, solving [4-3](#)  
personnel warning [3-2, D-26](#)  
physical dimensions [A-2 to A-6](#)  
pinouts  
    10/100/1000 ports [B-5](#)  
    10/100 ports [B-3](#)  
    1000BASE-T GBIC port [B-7](#)  
console port  
    DB-25 adapter [B-16](#)  
    RJ-45-to-DB-9 adapter cable [B-15](#)

pinouts (continued)  
    crossover cables  
        four twisted-pair, 10/100 ports [B-10](#)  
        four twisted-pair, 1000BASE-T ports [B-11](#)  
        two twisted-pair [B-9](#)  
    DB-25 adapters [B-16](#)  
    RJ-21 connector [B-11, B-13](#)  
    RJ-45-to-DB-25 terminal adapter [B-16](#)  
    RJ-45-to-DB-9 adapter cable [B-15](#)  
    RJ-45-to-DB-9 PC adapter cable [B-15](#)  
    straight-through cables  
        four twisted-pair, 10/100 ports [B-9](#)  
        four twisted-pair, 1000BASE-T ports [B-10](#)  
        two twisted-pair [B-8](#)  
port  
    LEDs [2-17 to 2-19, 2-22](#)  
    mode  
        LEDs [2-17 to 2-19, 2-21 to 2-23](#)  
        selecting [2-21](#)  
ports  
    See 10/100 ports, 10/100/1000 ports,  
    100BASE-FX ports, 1000BASE-SX,  
    GBIC module ports, LRE, and console  
    ports  
POST  
    problems, solving [4-5](#)  
POTS splitters, limitations and restrictions [3-39](#)

## power

- agency approvals [A-9](#)
- connecting to
  - DC [C-1 to C-11](#)
- requirements [A-2 to A-6](#)
- supply
  - AC connector [2-29](#)
  - DC connector [2-30](#)
  - RPS connector [2-31](#)

power connectors [2-29 to 2-31](#)

## procedures

- connecting to
  - DC power [C-1 to C-11](#)
- installation [3-10 to 3-25](#)
- IP address [3-50](#)

product disposal warning [3-4, D-17](#)publications, related [xxiii to xxv](#)


---

 Q
qualified personnel warning [3-2, D-26](#)


---

 R

## rack-mounting

- bracket mounting points [3-12 to 3-20](#)
- procedures [3-10 to 3-22](#)
- warning [3-10, D-8 to D-12](#)

## rear panel

- clearance [3-7](#)
- console port connector [2-31](#)
- described [2-27 to 2-29](#)
- illustrated [2-28 to 2-29](#)
- power connectors [2-29 to 2-31](#)

## Redundant Power System

See RPS

regulatory statements, EMC [3-4 to 3-6](#)related publications [xxiii to xxv](#)restricted access area warning [C-1, D-36](#)RJ-21 connector pinouts [B-11, B-13](#)rollover cable [B-14](#)

## RPS

- attaching the connector cover [3-24](#)
- connector [2-31](#)
- connector cover [3-24](#)
- described [2-31](#)
- LED [2-21](#)
- warning [3-4, D-1](#)

---

 S
safety agency approvals [A-7, A-8, A-9](#)safety warnings [3-2 to 3-4, D-1 to D-45](#)service personnel warning [3-2, D-44](#)

## SFP modules

1000BASE-LX [2-15](#)

1000BASE-SX [2-15](#)

1000BASE-ZX [2-15](#)

actuator button latch, removing [3-31](#)

bale-clasp latch, removing [3-31](#)

cabling recommendations [2-16](#)

connecting to [3-49 to 3-50](#)

described [2-14 to 2-15](#)

installation [3-28 to 3-30](#)

Mylar tab latch

    illustrated [3-29](#)

    removing [3-31](#)

    removing [3-30 to 3-32](#)

SFP ports, illustrated [2-7](#)

shelf-mounting [3-22](#)

SNMP network management platforms [2-32](#)

software switch management [2-32](#)

specifications [A-1 to A-9](#)

speed LED [2-22, 2-23, 2-24](#)

stacking the chassis warning [3-3, D-22](#)

status LED [2-22, 2-24](#)

straight-through cable

    connecting to

        10/100/1000 ports [3-34](#)

        10/100 ports [3-34](#)

        1000BASE-T GBIC module ports [3-47](#)

straight-through cable (continued)

    connectivity problems [4-4](#)

    pinout

        four twisted-pair, 10/100 ports [B-9](#)

        four twisted-pair, 1000BASE-T ports [B-10](#)

        two twisted-pair [B-8](#)

SunNet Manager [2-32](#)

system LED [2-20](#)

---

## T

table-mounting [3-22](#)

technical assistance [xxviii to xxix](#)

technical specifications [A-1 to A-9](#)

Telnet, and accessing the CLI [2-32](#)

temperature

    operating [A-2 to A-6](#)

    warning [3-3, D-12](#)

terminal-emulation software [1-4](#)

translated warnings [D-1 to D-45](#)

troubleshooting

    diagnosing problems [4-2 to 4-5](#)

    understanding POST results [4-2](#)

---

## U

uplink ports, LRE [2-11](#)

URLs, Cisco [xxv](#)

utilization

bandwidth [2-23 to 2-27](#)

LED [2-22, 2-23](#)

---

## V

verifying package contents [3-8 to 3-36](#)

---

## W

warnings

DC power [C-1, C-2, C-5](#)

defined [xvii](#)

installation [3-2 to 3-4](#)

translated [D-1 to D-45](#)

