



Connectors and Cables

This appendix describes the connectors, cables, and adapters that you use to connect the switch to other devices.

Connector Specifications

These sections describe the connectors used with the Catalyst 2950 switches and contains this information:

- [10/100 Ports, page B-1](#)
- [10/100/1000 Ports, page B-2](#)
- [100BASE-FX and 1000BASE-SX Ports, page B-4](#)
- [LRE Port, page B-3](#)
- [GigaStack GBIC Module Ports, page B-4](#)
- [SFP Module Ports, page B-5](#)
- [Console Port, page B-5](#)

10/100 Ports

The 10/100 Ethernet ports use standard RJ-45 connectors and Ethernet pinouts with internal crossovers, as shown by an **X** in the port name. These ports have the transmit (TD) and receive (RD) signals internally crossed so that a twisted-pair straight-through cable and adapter can be attached to the port. [Figure B-1](#) shows the pinout.

When connecting 10/100 ports to other devices, such as servers, workstations, and routers, you can use a two or four twisted-pair, straight-through cable wired for 10BASE-T and 100BASE-TX. [Figure B-10](#) shows the two twisted-pair, straight-through cable schematics. [Figure B-12](#) shows the four twisted-pair, straight-through cable schematics.

When connecting the ports to other devices, such as switches or repeaters, you can use a two or four twisted-pair, crossover cable. [Figure B-11](#) shows the two twisted-pair, crossover cable schematics. [Figure B-13](#) shows the four twisted-pair, crossover cable schematics.

You can use Category 3, 4, or 5 cabling when connecting to 10BASE-T devices. You must use Category 5 cabling when connecting to 100BASE-TX devices.

**Note**

Use a straight-through cable to connect two ports only when one port is designated with an **X**. Use a crossover cable to connect two ports when both ports are designated with an **X** or when both ports do not have an **X**.

Figure B-1 10/100 RJ-45 Pinouts

Pin	Label	1	2	3	4	5	6	7	8
1	RD+								
2	RD-								
3	TD+								
4	NC								
5	NC								
6	TD-								
7	NC								
8	NC								

10/100/1000 Ports

The 10/100/1000 Ethernet ports on Catalyst 2950T-24, Catalyst 2950T-48-SI, and Catalyst 2950 Long-Reach Ethernet (LRE) switches use standard RJ-45 connectors. [Figure B-2](#) shows the pinout.

**Note**

On the Catalyst 2950 LRE switches, the four input uplink ports are bundled as two logical ports, each consisting of a copper 10/100/1000 port and a fiber-optic small form-factor pluggable (SFP) module slot, respectively.

Within each logical port, you can use only the copper or the fiber-optic port at one time. If the Catalyst 2950 LRE switch senses more than two connections for both logical ports, the switch chooses the fiber-optic connections over the copper connections in default operation.

See the “[SFP Module Slots](#)” section on page 1-11 for more information on LRE uplink logical ports.

Connecting to 10BASE-T and 100BASE-TX Devices

When connecting the ports to 10BASE-T and 100BASE-TX devices, such as servers, workstations, and routers, you can use a two or four twisted-pair, straight-through cable wired for 10BASE-T and 100BASE-TX. [Figure B-10](#) shows the two twisted-pair, straight-through cable schematics. [Figure B-12](#) shows the four twisted-pair, straight-through cable schematics.

When connecting the ports to 10BASE-T- and 100BASE-TX devices, such as switches or repeaters, you can use a two or four twisted-pair, crossover cable. [Figure B-11](#) shows the two twisted-pair, crossover cable schematics. [Figure B-13](#) shows the four twisted-pair, crossover cable schematics.

You can use Category 3, 4, or 5 cabling when connecting to 10BASE-T devices. You must use Category 5 cabling when connecting to 100BASE-TX devices.

Connecting to 1000BASE-T Devices

When connecting the ports to 1000BASE-T devices, such as servers, workstations, and routers, you must use a four twisted-pair, Category 5, straight-through cable wired for 10BASE-T, 100BASE-TX, and 1000BASE-T. [Figure B-14](#) shows the straight-through cable schematics.

When connecting the ports to other devices, such as switches or repeaters, you must use a four twisted-pair, Category 5, crossover cable. [Figure B-15](#) shows the crossover cable schematics.



Note Be sure to use a four twisted-pair, Category 5 cable when connecting to a 1000BASE-T device.



Note Use a straight-through cable to connect two ports only when one port is designated with an **X**. Use a crossover cable to connect two ports when both ports are designated with an **X** or when both ports do not have an **X**.

Figure B-2 RJ-45 Pinouts for 10/100/1000 and 1000BASE-T GBIC Module Ports

Pin	Label
1	TP0+
2	TP0-
3	TP1+
4	TP2+
5	TP2-
6	TP1-
7	TP3+
8	TP3-

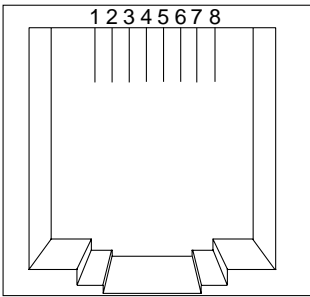

34751

LRE Port

The LRE port uses a single 50-pin RJ-21 connector, as shown in [Figure B-3](#). Each LRE port uses two pins. Because the Catalyst 2950ST-24 LRE and Catalyst 2950ST-24 LRE 997 switches use 48 pins, pin 25 on the top row and pin 50 on the bottom row are not used.

The Catalyst 2950ST-8 LRE switch uses 16 pins. Pins 9 through 25 on the top row and pins 34 through 50 on the bottom row are not used.

Figure B-3 RJ-21 Connector

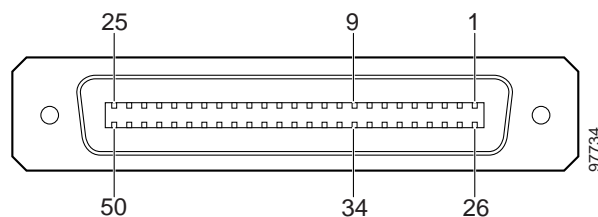

100BASE-FX and 1000BASE-SX Ports

The 100BASE-FX and 1000BASE-SX ports use MT-RJ connectors, shown in [Figure B-4](#). These ports use 50/125- or 62.5/125-micron multimode fiber-optic cabling.

You can connect a 100BASE-FX or 1000BASE-SX port to an SC or ST port on a target device by using one of the MT-RJ fiber-optic patch cables listed in [Table 2-1 on page 2-29](#). Use the Cisco part numbers in [Table 2-1](#) to order the patch cables that you need.

Figure B-4 MT-RJ Connector

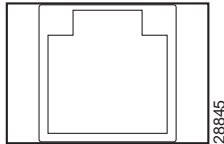

1000BASE-X GBIC Module Ports

1000BASE-X Gigabit Interface Converter (GBIC) module ports use duplex SC connectors, as shown in [Figure B-5](#).

Figure B-5 1000BASE-X SC Connector

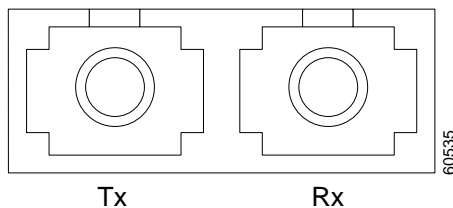

1000BASE-T GBIC Module Ports

The 1000BASE-T GBIC module port uses one RJ-45 connector, as shown in [Figure B-2](#).

GigaStack GBIC Module Ports

The GigaStack GBIC module ports use proprietary connectors, as shown in [Figure B-6](#). The GigaStack GBIC cables are proprietary, high-data-rate cables with enhanced signal integrity and EMI protection.



Caution

Do not use standard IEEE 1394 cables with the GigaStack GBIC.

Figure B-6 GigaStack Connector

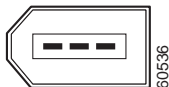

SFP Module Ports

The Catalyst 2950 LRE switch uses SFP modules for fiber-optic and copper uplink ports. See the Catalyst 2950 LRE switch release notes for a list of supported SFP modules. See [Figure B-7](#) and [Figure B-8](#).

Figure B-7 Fiber-Optic SFP Module LC Connector

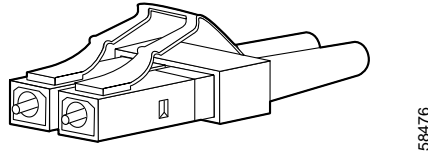

Warning

Invisible laser radiation may be emitted from disconnected fibers or connectors. Do not stare into beams or view directly with optical instruments. Statement 1051

Figure B-8 1000BASE-T SFP Module RJ-45 Connector

Pin	Label	1	2	3	4	5	6	7	8
1	TP0+								
2	TP0-								
3	TP1+								
4	TP2+								
5	TP2-								
6	TP1-								
7	TP3+								
8	TP3-								

60915

Console Port

The console port uses an 8-pin RJ-45 connector. You can connect a switch to a PC through the console port and the supplied RJ-45-to-DB-9 adapter cable. If you want to connect a switch to a terminal, you need to provide an RJ-45-to-DB-25 female DTE adapter. You can order a kit (part number ACS-DSBUASYN=) with that adapter from Cisco. For console-port and adapter-pinout information, see [Table B-3](#) and [Table B-4](#).

Identifying a Crossover Cable

You can identify a crossover cable by comparing the two modular cable ends. Hold the cable ends side-by-side, with the tab at the back. The wire connected to the pin on the outside of the left plug should be the same color as the wire connected to the pin on the outside of the right plug. (See [Figure B-9](#).)

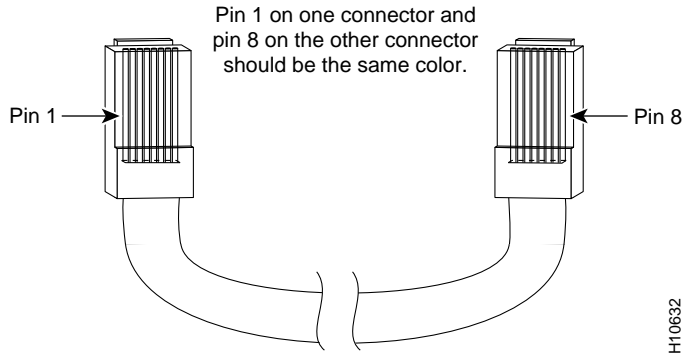
Figure B-9 Identifying a Crossover Cable

Cable and Adapter Specifications

These sections describe the cables and adapters used with Catalyst 2950 switches.

- [Two Twisted-Pair Cable Pinouts, page B-6](#)
- [Four Twisted-Pair Cable Pinouts for 10/100 Ports, page B-7](#)
- [Four Twisted-Pair Cable Pinouts for 1000BASE-T Ports, page B-8](#)
- [RJ-21 Cable Pinouts, page B-8](#)

Two Twisted-Pair Cable Pinouts

[Figure B-10](#) and [Figure B-11](#) show the schematics of two twisted-pair cables for 10/100 ports.

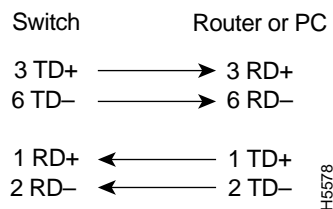
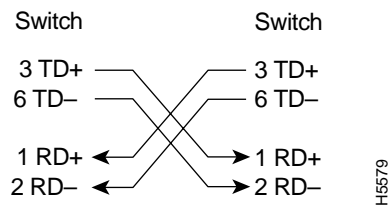
Figure B-10 Two Twisted-Pair Straight-Through Cable Schematic for 10/100 Ports**Figure B-11 Two Twisted-Pair Crossover Cable Schematic for 10/100 Ports**

Four Twisted-Pair Cable Pinouts for 10/100 Ports

Figure B-12 and Figure B-13 show the schematics of four twisted-pair cables for 10/100 ports.

Figure B-12 Four Twisted-Pair Straight-Through Cable Schematic for 10/100 Ports

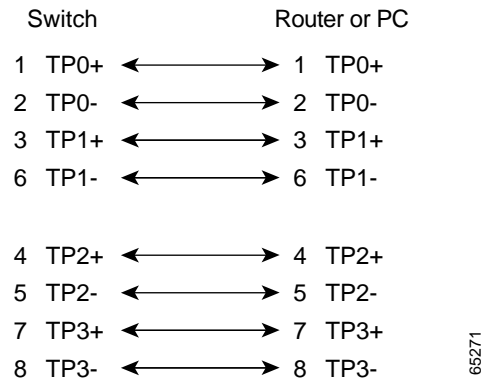
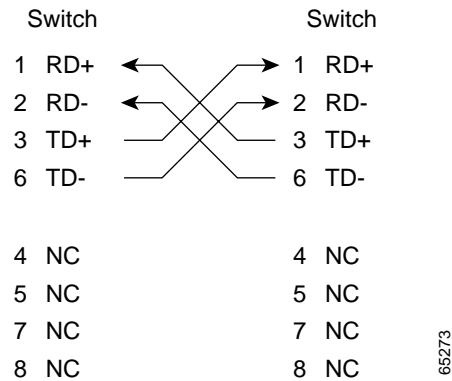

Figure B-13 Four Twisted-Pair Crossover Cable Schematic for 10/100 Ports



Four Twisted-Pair Cable Pinouts for 1000BASE-T Ports

Figure B-14 and Figure B-15 show the schematics of four twisted-pair cables for 10/100/1000 ports on Catalyst 2950T-24 switches, Catalyst 2950 LRE switches, and 1000BASE-T GBIC module ports.

Figure B-14 Four Twisted-Pair Straight-Through Cable Schematic for 10/100/1000 and 1000BASE-T GBIC Module Ports

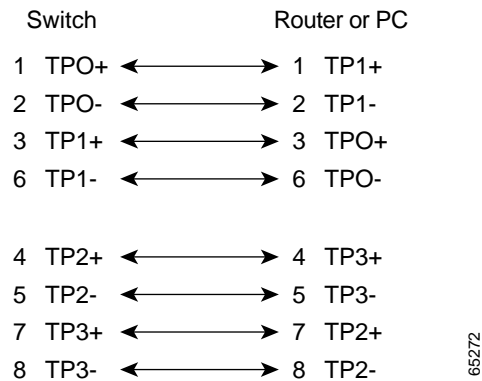
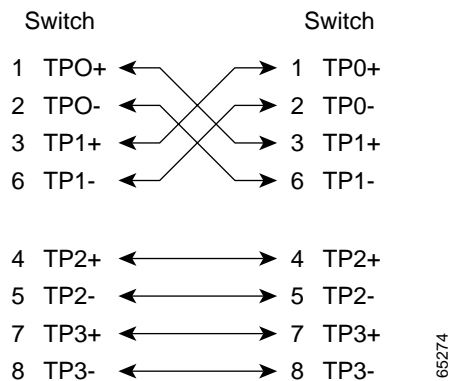

Figure B-15 Four Twisted-Pair Crossover Cable Schematics for 10/100/1000 and 1000BASE-T GBIC Module Ports



RJ-21 Cable Pinouts

Table B-1 lists the RJ-21 cable pinouts on the Catalyst 2950ST-24 LRE and Catalyst 2950ST-24 LRE 997 switches.

Table B-1 Catalyst 2950ST-24 LRE and Catalyst 2950ST-24 LRE 997 Switch RJ-21 Cable Pinouts

Function	Pin	Pin	Function
Port 1 Tip	1	26	Port 1 Ring
Port 2 Tip	2	27	Port 2 Ring
Port 3 Tip	3	28	Port 3 Ring
Port 4 Tip	4	29	Port 4 Ring

Table B-1 Catalyst 2950ST-24 LRE and Catalyst 2950ST-24 LRE 997 Switch RJ-21 Cable Pinouts

Function	Pin	Pin	Function
Port 5 Tip	5	30	Port 5 Ring
Port 6 Tip	6	31	Port 6 Ring
Port 7 Tip	7	32	Port 7 Ring
Port 8 Tip	8	33	Port 8 Ring
Port 9 Tip	9	34	Port 9 Ring
Port 10 Tip	10	35	Port 10 Ring
Port 11 Tip	11	36	Port 11 Ring
Port 12 Tip	12	37	Port 12 Ring
Port 13 Tip	13	38	Port 13 Ring
Port 14 Tip	14	39	Port 14 Ring
Port 15 Tip	15	40	Port 15 Ring
Port 16 Tip	16	41	Port 16 Ring
Port 17 Tip	17	42	Port 17 Ring
Port 18 Tip	18	43	Port 18 Ring
Port 19 Tip	19	44	Port 19 Ring
Port 20 Tip	20	45	Port 20 Ring
Port 21 Tip	21	46	Port 21 Ring
Port 22 Tip	22	47	Port 22 Ring
Port 23 Tip	23	48	Port 23 Ring
Port 24 Tip	24	49	Port 24 Ring
No connect	25	50	No connect

[Table B-2](#) lists the RJ-21 cable pinouts on the Catalyst 2950ST-8 LRE switches.

Table B-2 Catalyst 2950ST-8 LRE Switch RJ-21 Cable Pinouts

Function	Pin	Pin	Function
Port 1 Tip	1	26	Port 1 Ring
Port 2 Tip	2	27	Port 2 Ring
Port 3 Tip	3	28	Port 3 Ring
Port 4 Tip	4	29	Port 4 Ring
Port 5 Tip	5	30	Port 5 Ring
Port 6 Tip	6	31	Port 6 Ring
Port 7 Tip	7	32	Port 7 Ring
Port 8 Tip	8	33	Port 8 Ring
No connect	9	34	No connect
No connect	10	35	No connect

Table B-2 Catalyst 2950ST-8 LRE Switch RJ-21 Cable Pinouts (continued)

Function	Pin	Pin	Function
No connect	11	36	No connect
No connect	12	37	No connect
No connect	13	38	No connect
No connect	14	39	No connect
No connect	15	40	No connect
No connect	16	41	No connect
No connect	17	42	No connect
No connect	18	43	No connect
No connect	19	44	No connect
No connect	20	45	No connect
No connect	21	46	No connect
No connect	22	47	No connect
No connect	23	48	No connect
No connect	24	49	No connect
No connect	25	50	No connect

Adapter Pinouts

[Table B-3](#) lists the pinouts for the console port, the RJ-45-to-DB-9 adapter cable, and the console device.

Table B-3 Console Port Signaling and RJ-45-to-DB-9 Adapter Cabling

Console Port (DTE)	RJ-45-to-DB-9 Adapter Cable		Console Device
Signal	RJ-45 Pin	DB-9 Pin	Signal
RTS	1	8	CTS
Not connected	2	6	DSR
TxD	3	2	RxD
GND	4	5	GND
GND	5	5	GND
RxD	6	3	TxD
Not connected	7	4	DTR
CTS	8	7	RTS

Table B-4 lists the pinouts for the console port, RJ-45-to-DB-25 female DTE adapter, and the console device.



Note

The RJ-45-to-DB-25 female DTE adapter is not supplied with the switch. You can order a kit (part number ACS-DSBUASYN=) with that adapter from Cisco.

Table B-4 Console Port Signaling and Cabling Using a DB-25 Adapter

Console Port (DTE)	RJ-45-to-DB-9 Adapter Cable		RJ-45-to-DB-25 Terminal Adapter	Console Device
Signal	RJ-45 Pin	DB-9 Pin	DB-25 Pin	Signal
RTS	1	8	5	CTS
Not connected	2	6	6	DSR
TxD	3	2	3	RxD
GND	4	5	7	GND
GND	5	5	7	GND
RxD	6	3	2	TxD
Not connected	7	4	20	DTR
CTS	8	7	4	RTS

