



Assigning the Switch IP Address and Default Gateway

This chapter describes how to create the initial switch configuration (for example, assign the switch IP address and default gateway information) for the Catalyst 2940 switch by using a variety of automatic and manual methods.



Note

For complete syntax and usage information for the commands used in this chapter, refer to the command reference for this release and the *Cisco IOS IP and IP Routing Command Reference, Release 12.1*.

This chapter consists of these sections:

- [Understanding the Boot Process, page 4-1](#)
- [Assigning Switch Information, page 4-2](#)
- [Checking and Saving the Running Configuration, page 4-10](#)

Understanding the Boot Process

To start your switch, you need to follow the procedures in the hardware installation guide about installing and powering on the switch, and setting up the initial configuration (IP address, subnet mask, default gateway, secret and Telnet passwords, and so forth) of the switch.

The normal boot process involves the operation of the boot loader software, which performs these activities:

- Performs low-level CPU initialization. It initializes the CPU registers, which control where physical memory is mapped, its quantity, its speed, and so forth.
- Performs power-on self-test (POST) for the CPU subsystem. It tests the CPU DRAM and the portion of the flash device that makes up the flash file system.
- Initializes the flash file system on the system board.
- Loads a default operating system software image into memory and boots the switch.

The boot loader provides access to the flash file system before the operating system is loaded. Normally, the boot loader is used only to load, uncompress, and launch the operating system. After the boot loader gives the operating system control of the CPU, the boot loader is not active until the next system reset or power-on.

The boot loader also provides trap-door access into the system if the operating system has problems serious enough that it cannot be used. The trap-door mechanism provides enough access to the system so that if it is necessary, you can format the flash file system, re-install the operating system software image by using the XMODEM Protocol, recover from a lost or forgotten password, and finally restart the operating system. For more information, see the [“Recovering from Corrupted Software”](#) section on page 27-2 and the [“Recovering from Lost or Forgotten Passwords”](#) section on page 27-2.

Before you can assign switch information, make sure you have connected a PC or terminal to the console port, and configured the PC or terminal-emulation software baud rate and character format to match these of the switch console port:

- Baud rate default is 9600.
- Data bits default is 8.
- Stop bits default is 1.
- Parity settings default is none.



Note

If you are using Express Setup, do not connect any devices to the switch before starting Express Setup.

Refer to your switch hardware installation guide for more information.

Assigning Switch Information

You can assign IP information through the switch Express Setup program, through the command-line-interface (CLI)-based setup program, through a DHCP server, or manually by using the CLI. If you are an experienced user familiar with the switch configuration steps, manually configure the switch. Otherwise, use one of the setup programs.

Use the switch Express Setup or CLI-based setup program if you want to be prompted for specific IP information. With these programs, you can also configure a default gateway, a host name, and a switch (enable secret) password. You also have the option of assigning a Telnet password (to provide security during remote management) and enabling Simple Network Management Protocol (SNMP). The CLI-based setup program also allows you to configure your switch as a command or member switch of a cluster or as a standalone switch. For more information about the Express Setup and CLI-based setup programs, refer to the hardware installation guide for your switch.

Use a DHCP server for centralized control and automatic assignment of IP information after the server is configured.



Note

If you are using DHCP, do not respond to any of the questions in the setup program until the switch receives the dynamically assigned IP address and reads the configuration file.

This section contains this configuration information:

- [Default Switch Information, page 4-3](#)
- [Understanding DHCP-Based Autoconfiguration, page 4-3](#)
- [Configuring DHCP-Based Autoconfiguration, page 4-4](#)
- [Manually Assigning IP Information, page 4-9](#)

Default Switch Information

Table 4-1 shows the default switch information.

Table 4-1 Default Switch Information

Feature	Default Setting
IP address and subnet mask	No IP address or subnet mask are defined.
Default gateway	No default gateway is defined.
Enable secret password	No password is defined.
Host name	The factory-assigned default host name is <i>Switch</i> .
Telnet password	No password is defined.
Cluster command switch functionality	Disabled.
Cluster name	No cluster name is defined.

Understanding DHCP-Based Autoconfiguration

DHCP provides configuration information to Internet hosts and internetworking devices. This protocol consists of two components: one for delivering configuration parameters from a DHCP server to a device and a mechanism for allocating network addresses to devices. DHCP is built on a client-server model, in which designated DHCP servers allocate network addresses and deliver configuration parameters to dynamically configured devices.

During DHCP-based autoconfiguration, your switch (DHCP client) is automatically configured at startup with IP address information and a configuration file.

With DHCP-based autoconfiguration, no DHCP client-side configuration is needed on your switch. However, you need to configure the DHCP server for various lease options associated with IP addresses. If you are using DHCP to relay the configuration file location on the network, you might also need to configure a TFTP server and a Domain Name System (DNS) server.

The DHCP server for your switch can be on the same LAN or on a different LAN than the switch. If the DHCP server is running on a different LAN, you should configure a DHCP relay device between your switch and the DHCP server. A relay device forwards broadcast traffic between two directly connected LANs. A router does not forward broadcast packets, but it forwards packets based on the destination IP address in the received packet.

DHCP-based autoconfiguration replaces the BOOTP client functionality on your switch.

DHCP Client Request Process

When you boot your switch, the DHCP client is invoked and requests configuration information from a DHCP server when the configuration file is not present on the switch.

DHCP autoconfiguration does not occur under these conditions:

- When a configuration file is present and the **service config** global configuration command is disabled on the switch.
- When a configuration file is present and the **service config** global configuration command is enabled on the switch. In this case, the switch broadcasts TFTP requests for the configuration file.

Figure 4-1 shows the sequence of messages that are exchanged between the DHCP client and the DHCP server.

Figure 4-1 DHCP Client and Server Message Exchange

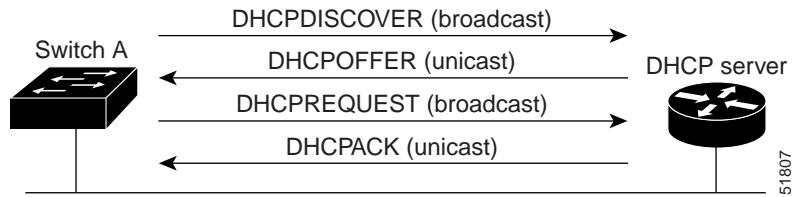

The client, Switch A, broadcasts a DHCPDISCOVER message to locate a DHCP server. The DHCP server offers configuration parameters (such as an IP address, subnet mask, gateway IP address, DNS IP address, a lease for the IP address, and so forth) to the client in a DHCPOFFER unicast message.

In a DHCPREQUEST broadcast message, the client returns a formal request for the offered configuration information to the DHCP server. The formal request is broadcast so that all other DHCP servers that received the DHCPDISCOVER broadcast message from the client can reclaim the IP addresses that they offered to the client.

The DHCP server confirms that the IP address has been allocated to the client by returning a DHCPACK unicast message to the client. With this message, the client and server are bound, and the client uses configuration information received from the server. The amount of information the switch receives depends on how you configure the DHCP server. For more information, see the “[DHCP Server Configuration Guidelines](#)” section on page 4-5.

If the configuration parameters sent to the client in the DHCPOFFER unicast message are invalid (a configuration error exists), the client returns a DHCPDECLINE broadcast message to the DHCP server.

The DHCP server sends the client a DHCPNAK denial broadcast message, which means that the offered configuration parameters have not been assigned, that an error has occurred during the negotiation of the parameters, or that the client has been slow in responding to the DHCPOFFER message (the DHCP server assigned the parameters to another client).

A DHCP client might receive offers from multiple DHCP or BOOTP servers and can accept any of the offers; however, the client usually accepts the first offer it receives. The offer from the DHCP server is not a guarantee that the IP address is allocated to the client; however, the server usually reserves the address until the client has had a chance to formally request the address. If the switch accepts replies from a BOOTP server and configures itself, the switch broadcasts, instead of unicasts, TFTP requests to obtain the switch configuration file.

Configuring DHCP-Based Autoconfiguration

These sections describe how to configure DHCP-based autoconfiguration.

- [DHCP Server Configuration Guidelines, page 4-5](#)
- [Configuring the TFTP Server, page 4-5](#)
- [Configuring the DNS, page 4-6](#)
- [Configuring the Relay Device, page 4-6](#)
- [Obtaining Configuration Files, page 4-7](#)
- [Example Configuration, page 4-8](#)

If your DHCP server is a Cisco device, or if you are configuring the switch as a DHCP server, refer to the “*IP Addressing and Services*” section in the *Cisco IOS IP and IP Routing Configuration Guide for Cisco IOS Release 12.1* for additional information about configuring DHCP.

DHCP Server Configuration Guidelines

Follow these guidelines if you are configuring a device as a DHCP server:

You should configure the DHCP server with reserved leases that are bound to each switch by the switch hardware address.

If you want the switch to receive IP address information, you must configure the DHCP server with these lease options:

- IP address of the client (required)
- Subnet mask of the client (required)
- DNS server IP address (optional)
- Router IP address (default gateway address to be used by the switch) (required)

If you want the switch to receive the configuration file from a TFTP server, you must configure the DHCP server with these lease options:

- TFTP server name (required)
- Boot filename (the name of the configuration file that the client needs) (recommended)
- Host name (optional)

Depending on the settings of the DHCP server, the switch can receive IP address information, the configuration file, or both.

If you do not configure the DHCP server with the lease options described previously, it replies to client requests with only those parameters that are configured. If the IP address and subnet mask are not in the reply, the switch is not configured. If the router IP address or TFTP server name are not found, the switch might send broadcast, instead of unicast, TFTP requests. Unavailability of other lease options does not affect autoconfiguration.

Configuring the TFTP Server

Based on the DHCP server configuration, the switch attempts to download one or more configuration files from the TFTP server. If you configured the DHCP server to respond to the switch with all the options required for IP connectivity to the TFTP server, and if you configured the DHCP server with a TFTP server name, address, and configuration filename, the switch attempts to download the specified configuration file from the specified TFTP server.

If you did not specify the configuration filename, the TFTP server, or if the configuration file could not be downloaded, the switch attempts to download a configuration file by using various combinations of filenames and TFTP server addresses. The files include the specified configuration filename (if any) and these files: `network-config`, `cisconet.cfg`, `hostname.config`, or `hostname.cfg`, where `hostname` is the switch's current hostname. The TFTP server addresses used include the specified TFTP server address (if any) and the broadcast address (255.255.255.255).

For the switch to successfully download a configuration file, the TFTP server must contain one or more configuration files in its base directory. The files can include these files:

- The configuration file named in the DHCP reply (the actual switch configuration file).
- The network-config or the cisco.net.cfg file (known as the default configuration files).
- The router-config or the ciscotr.conf file (These files contain commands common to all switches. Normally, if the DHCP and TFTP servers are properly configured, these files are not accessed.)

If you specify the TFTP server name in the DHCP server-lease database, you must also configure the TFTP server name-to-IP-address mapping in the DNS-server database.

If the TFTP server to be used is on a different LAN from the switch, or if it is to be accessed by the switch through the broadcast address (which occurs if the DHCP server response does not contain all the required information described previously), a relay must be configured to forward the TFTP packets to the TFTP server. For more information, see the “[Configuring the Relay Device](#)” section on page 4-6. The preferred solution is to configure the DHCP server with all the required information.

Configuring the DNS

The DHCP server uses the DNS server to resolve the TFTP server name to an IP address. You must configure the TFTP server name-to-IP address map on the DNS server. The TFTP server contains the configuration files for the switch.

You can configure the IP addresses of the DNS servers in the lease database of the DHCP server from where the DHCP replies will retrieve them. You can enter up to two DNS server IP addresses in the lease database.

The DNS server can be on the same or on a different LAN as the switch. If it is on a different LAN, the switch must be able to access it through a router.

Configuring the Relay Device

You must configure a relay device, also referred to as a relay agent, when a switch sends broadcast packets that require a response from a host on a different LAN. Examples of broadcast packets that the switch might send are DHCP, DNS, and in some cases, TFTP packets. You must configure this relay device to forward received broadcast packets on an interface to the destination host.

If the relay device is a Cisco router, enable IP routing (**ip routing** global configuration command), and configure helper addresses by using the **ip helper-address** interface configuration command.

For example, in [Figure 4-2](#), configure the router interfaces as follows:

On interface 10.0.0.2:

```
router(config-if)# ip helper-address 20.0.0.2
router(config-if)# ip helper-address 20.0.0.3
router(config-if)# ip helper-address 20.0.0.4
```

On interface 20.0.0.1

```
router(config-if)# ip helper-address 10.0.0.1
```

Figure 4-2 Relay Device Used in Autoconfiguration

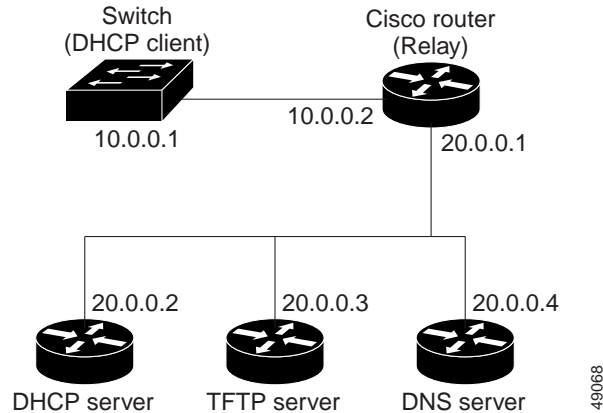

Obtaining Configuration Files

Depending on the availability of the IP address and the configuration filename in the DHCP reserved lease, the switch obtains its configuration information in these ways:

- The IP address and the configuration filename is reserved for the switch and provided in the DHCP reply (one-file read method).

The switch receives its IP address, subnet mask, TFTP server address, and the configuration filename from the DHCP server. The switch sends a unicast message to the TFTP server to retrieve the named configuration file from the base directory of the server, and upon receipt, it completes its boot-up process.

- The IP address and the configuration filename is reserved for the switch, but the TFTP server address is not provided in the DHCP reply (one-file read method).

The switch receives its IP address, subnet mask, and the configuration filename from the DHCP server. The switch sends a broadcast message to a TFTP server to retrieve the named configuration file from the base directory of the server, and upon receipt, it completes its boot-up process.

- Only the IP address is reserved for the switch and provided in the DHCP reply. The configuration filename is not provided (two-file read method).

The switch receives its IP address, subnet mask, and the TFTP server address from the DHCP server. The switch sends a unicast message to the TFTP server to retrieve the network-config or cisco.net.cfg default configuration file. (If the network-config file cannot be read, the switch reads the cisco.net.cfg file.)

The default configuration file contains the host names-to-IP-address mapping for the switch. The switch fills its host table with the information in the file and obtains its host name. If the host name is not found in the file, the switch uses the host name in the DHCP reply. If the host name is not specified in the DHCP reply, the switch uses the default *Switch* as its host name.

After obtaining its host name from the default configuration file or the DHCP reply, the switch reads the configuration file that has the same name as its host name (*hostname-config* or *hostname.cfg*, depending on whether network-config or cisco.net.cfg was read earlier) from the TFTP server. If the cisco.net.cfg file is read, the filename of the host is truncated to eight characters.

If the switch cannot read the network-config, cisco.net.cfg, or the hostname file, it reads the router-config file. If the switch cannot read the router-config file, it reads the ciscotr.cfg file.

**Note**

The switch broadcasts TFTP server requests if the TFTP server is not obtained from the DHCP replies, if all attempts to read the configuration file through unicast transmissions fail, or if the TFTP server name cannot be resolved to an IP address.

Example Configuration

Figure 4-3 shows a sample network for retrieving IP information by using DHCP-based autoconfiguration.

Figure 4-3 DHCP-Based Autoconfiguration Network Example

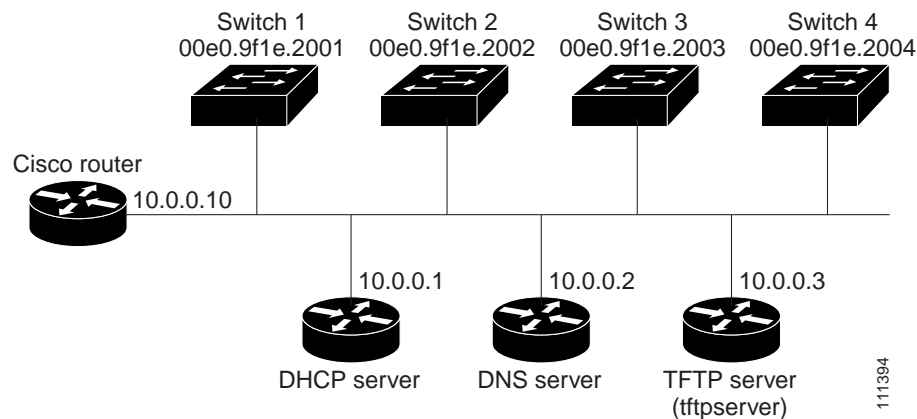

Table 4-2 shows the configuration of the reserved leases on the DHCP server.

Table 4-2 DHCP Server Configuration

	Switch-1	Switch-2	Switch-3	Switch-4
Binding key (hardware address)	00e0.9f1e.2001	00e0.9f1e.2002	00e0.9f1e.2003	00e0.9f1e.2004
IP address	10.0.0.21	10.0.0.22	10.0.0.23	10.0.0.24
Subnet mask	255.255.255.0	255.255.255.0	255.255.255.0	255.255.255.0
Router address	10.0.0.10	10.0.0.10	10.0.0.10	10.0.0.10
DNS server address	10.0.0.2	10.0.0.2	10.0.0.2	10.0.0.2
TFTP server name	tftpserver or 10.0.0.3	tftpserver or 10.0.0.3	tftpserver or 10.0.0.3	tftpserver or 10.0.0.3
Boot filename (configuration file) (optional)	switcha-confg	switchb-confg	switchc-confg	switchd-confg
Host name (optional)	switcha	switchb	switchc	switchd

DNS Server Configuration

The DNS server maps the TFTP server name *tftpserver* to IP address 10.0.0.3.

TFTP Server Configuration (on UNIX)

The TFTP server base directory is set to `/tftpserver/work/`. This directory contains the `network-config` file used in the two-file read method. This file contains the host name to be assigned to the switch based on its IP address. The base directory also contains a configuration file for each switch (`switcha-config`, `switchb-config`, and so forth) as shown in this display:

```
prompt> cd /tftpserver/work/
prompt> ls
network-config
switcha-config
switchb-config
switchc-config
switchd-config
prompt> cat network-config
ip host switch1 10.0.0.21
ip host switch2 10.0.0.22
ip host switch3 10.0.0.23
ip host switch4 10.0.0.24
```

DHCP Client Configuration

No configuration file is present on Switch A through Switch D.

Configuration Explanation

In [Figure 4-3](#), Switch A reads its configuration file as follows:

- It obtains its IP address 10.0.0.21 from the DHCP server.
- If no configuration filename is given in the DHCP server reply, Switch A reads the `network-config` file from the base directory of the TFTP server.
- It adds the contents of the `network-config` file to its host table.
- It reads its host table by indexing its IP address 10.0.0.21 to its host name (`switcha`).
- It reads the configuration file that corresponds to its host name; for example, it reads `switch1-config` from the TFTP server.

Switches B through D retrieve their configuration files and IP addresses in the same way.

Manually Assigning IP Information

Beginning in privileged EXEC mode, follow these steps to manually assign IP information to VLANs or ports:

	Command	Purpose
Step 1	configure terminal	Enter global configuration mode.
Step 2	interface vlan <i>vlan-id</i>	Enter interface configuration mode, and enter the VLAN to which the IP information is assigned. The range is 1 to 1001
Step 3	ip address <i>ip-address subnet-mask</i>	Enter the IP address and subnet mask.
Step 4	exit	Return to global configuration mode.

	Command	Purpose
Step 5	ip default-gateway <i>ip-address</i>	Enter the IP address of the next-hop router interface that is directly connected to the switch where a default gateway is being configured. The default gateway receives IP packets with unresolved destination IP addresses from the switch. Once the default gateway is configured, the switch has connectivity to the remote networks with which a host needs to communicate. Note When your switch is configured to route with IP, it does not need to have a default gateway set.
Step 6	end	Return to privileged EXEC mode.
Step 7	show interfaces vlan <i>vlan-id</i>	Verify the configured IP address.
Step 8	show ip redirects	Verify the configured default gateway.
Step 9	copy running-config startup-config	(Optional) Save your entries in the configuration file.

To remove the switch IP address, use the **no ip address** interface configuration command. If you are removing the address through a Telnet session, your connection to the switch will be lost. To remove the default gateway address, use the **no ip default-gateway** global configuration command.

For information on setting the switch system name, protecting access to privileged EXEC commands, and setting time and calendar services, see [Chapter 6, “Administering the Switch.”](#)

Checking and Saving the Running Configuration

You can check the configuration settings you entered or changes you made by entering the **show running-config** privileged EXEC command: For information about the output of this command, refer to the *Cisco IOS Configuration Fundamental Command Reference for Release 12.1*.

To store the configuration or changes you have made to your startup configuration in flash memory, enter the **copy running-config startup-config** privileged EXEC command. This command saves the configuration settings that you made. If you fail to do this, your configuration will be lost the next time you reload the system. To display information stored in the NVRAM section of flash memory, use the **show startup-config** or **more startup-config** privileged EXEC command.