



## Configuring IGMP Snooping and MVR

This chapter describes how to configure Internet Group Management Protocol (IGMP) snooping on your Catalyst 2940 switch, including an application of local IGMP snooping, Multicast VLAN Registration (MVR). It also includes procedures for controlling multicast group membership by using IGMP filtering and procedures for configuring the IGMP throttling action.



### Note

For complete syntax and usage information for the commands used in this chapter, refer to the switch command reference for this release and the *Cisco IOS Release Network Protocols Command Reference, Part 1, for Release 12.1*.

This chapter consists of these sections:

- [Understanding IGMP Snooping, page 16-1](#)
- [Configuring IGMP Snooping, page 16-6](#)
- [Displaying IGMP Snooping Information, page 16-12](#)
- [Understanding Multicast VLAN Registration, page 16-14](#)
- [Configuring MVR, page 16-16](#)
- [Displaying MVR Information, page 16-20](#)
- [Configuring IGMP Filtering and Throttling, page 16-21](#)
- [Displaying IGMP Filtering and Throttling Configuration, page 16-27](#)



### Note

For MAC addresses that map to IP multicast groups, you can either manage them through features such as IGMP snooping and MVR, or you can use static MAC addresses. However, you cannot use both methods simultaneously. Therefore, before using IGMP snooping or MVR, you should remove all statically configured MAC addresses that map to IP multicast groups.

## Understanding IGMP Snooping

Layer 2 switches can use IGMP snooping to constrain the flooding of multicast traffic by dynamically configuring Layer 2 interfaces so that multicast traffic is forwarded to only those interfaces associated with IP multicast devices. As the name implies, IGMP snooping requires the LAN switch to snoop on the IGMP transmissions between the host and the router and to keep track of multicast groups and member ports. When the switch receives an IGMP report from a host for a particular multicast group,

the switch adds the host port number to the forwarding table entry; when it receives an IGMP Leave Group message from a host, it removes the host port from the table entry. It also periodically deletes entries if it does not receive IGMP membership reports from the multicast clients.

**Note**

For more information on IP multicast and IGMP, refer to RFC 1112 and RFC 2236.

The multicast router sends out periodic IGMP general queries to all VLANs. When IGMP snooping is enabled, the switch responds to the router queries with only one join request per MAC multicast group, and the switch creates one entry per VLAN in the Layer 2 forwarding table for each MAC group from which it receives an IGMP join request. All hosts interested in this multicast traffic send join requests and are added to the forwarding table entry.

Layer 2 multicast groups learned through IGMP snooping are dynamic. However, you can statically configure MAC multicast groups by using the **ip igmp snooping vlan static** global configuration command. If you specify group membership for a multicast group address statically, your setting supersedes any automatic manipulation by IGMP snooping. Multicast group membership lists can consist of both user-defined and IGMP snooping-learned settings.

If a port spanning-tree, a port group, or a VLAN ID change occurs, the IGMP snooping-learned multicast groups from this port on the VLAN are deleted.

The switches support a maximum of 255 IP multicast groups.

These sections describe characteristics of IGMP snooping on the switch:

- [IGMP Versions, page 16-2](#)
- [Joining a Multicast Group, page 16-3](#)
- [Leaving a Multicast Group, page 16-4](#)
- [Immediate-Leave Processing, page 16-5](#)
- [IGMP Report Suppression, page 16-5](#)
- [Source-Only Networks, page 16-5](#)

## IGMP Versions

The switch supports IGMP version 1, IGMP version 2, and IGMP version 3. These versions are interoperable on the switch. For example, if IGMP snooping is enabled on an IGMPv2 switch and the switch receives an IGMPv3 report from a host, the switch can forward the IGMPv3 report to the multicast router.

**Note**

The switches support IGMPv3 snooping based only on the destination multicast MAC address. They do not support snooping based on the source MAC address or on proxy reports.

An IGMPv3 switch supports Basic IGMPv3 Snooping Support (BISS), which includes support for the snooping features on IGMPv1 and IGMPv2 switches and for IGMPv3 membership report messages. BISS constrains the flooding of multicast traffic when your network includes IGMPv3 hosts. It constrains traffic to approximately the same set of ports as the IGMP snooping feature on IGMPv2 or IGMPv1 hosts.

**Note**

IGMPv3 join and leave messages are not supported on switches running IGMP filtering or MVR.

An IGMPv3 switch can receive messages from and forward messages to a device running the Source Specific Multicast (SSM) feature. For more information, refer to the “Configuring IP Multicast Layer 3 Switching” chapter in the *Catalyst 4500 Series Switch Cisco IOS Software Configuration Guide, Cisco IOS Release 12.1(12c)EW* at this URL:

[http://www.cisco.com/univercd/cc/td/doc/product/lan/cat4000/12\\_1\\_12/config/mcastmls.htm](http://www.cisco.com/univercd/cc/td/doc/product/lan/cat4000/12_1_12/config/mcastmls.htm)

## Joining a Multicast Group

When a host connected to the switch wants to join an IP multicast group, it sends an unsolicited IGMP join message, specifying the IP multicast group to join. Alternatively, when the switch receives a general query from the router, it forwards the query to all ports in the VLAN. Hosts wanting to join the multicast group respond by sending a join message to the switch. The switch CPU creates a multicast forwarding-table entry for the group if it is not already present. The CPU also adds the interface where the join message was received to the forwarding-table entry. The host associated with that interface receives multicast traffic for that multicast group. See [Figure 16-1](#).

**Figure 16-1** Initial IGMP Join Message

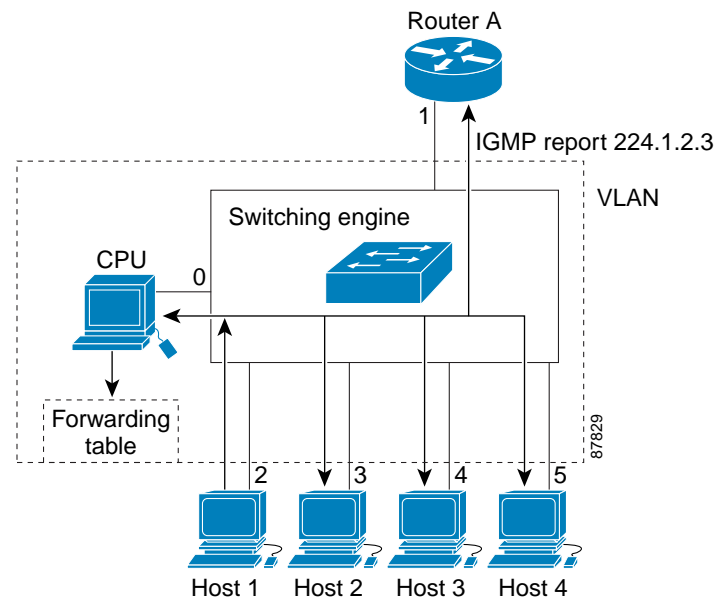

Router A sends a general query to the switch, which forwards the query to ports 2 through 5, all members of the same VLAN. Host 1 wants to join multicast group 224.1.2.3 and multicasts an IGMP membership report (IGMP join message) to the group with the equivalent MAC destination address of 0x0100.5E01.0203. When the CPU receives the IGMP report multicast by Host 1, the CPU uses the information in the IGMP report to set up a forwarding-table entry, as shown in [Table 16-1](#), that includes the port numbers of Host 1, the router, and the switch internal CPU.

**Table 16-1** IGMP Snooping Forwarding Table

Destination Address	Type of Packet	Ports
0100.5exx.xxxx	IGMP	0
0100.5e01.0203	!IGMP	1, 2

Note that the switch hardware can distinguish IGMP information packets from other packets for the multicast group.

- The first entry in the table tells the switching engine to send IGMP packets to only the switch CPU. This prevents the CPU from becoming overloaded with multicast frames.
- The second entry tells the switching engine to send frames addressed to the 0x0100.5E01.0203 multicast MAC address that are not IGMP packets (!IGMP) to the router and to the host that has joined the group.

If another host (for example, Host 4) sends an unsolicited IGMP join message for the same group (Figure 16-2), the CPU receives that message and adds the port number of Host 4 to the forwarding table as shown in Table 16-2. Note that because the forwarding table directs IGMP messages to only the CPU, the message is not flooded to other ports on the switch. Any known multicast traffic is forwarded to the group and not to the CPU. Any unknown multicast traffic is flooded to the VLAN and sent to the CPU until it becomes known.

Figure 16-2 Second Host Joining a Multicast Group

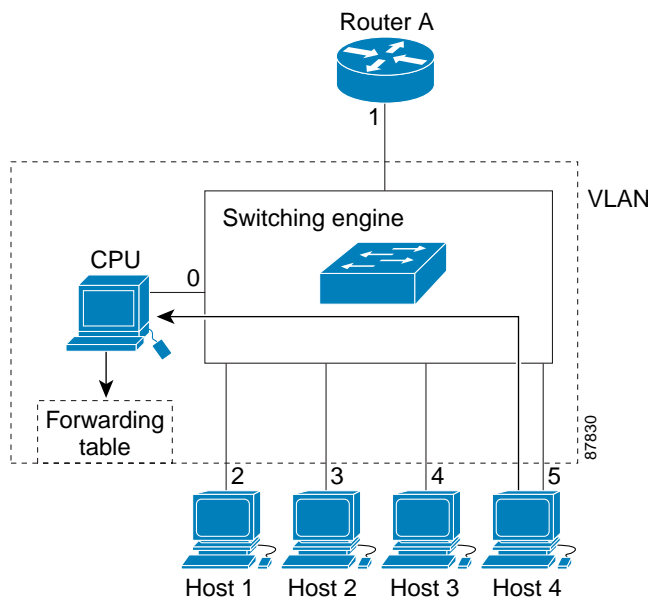

Table 16-2 Updated IGMP Snooping Forwarding Table

Destination Address	Type of Packet	Ports
0100.5exx.xxxx	IGMP	0
0100.5e01.0203	!IGMP	1, 2, 5

## Leaving a Multicast Group

The router sends periodic multicast general queries and the switch forwards these queries through all ports in the VLAN. Interested hosts respond to the queries. If at least one host in the VLAN wishes to receive multicast traffic, the router continues forwarding the multicast traffic to the VLAN. The switch forwards multicast group traffic to only those hosts listed in the forwarding table for that Layer 2 multicast group.

When hosts want to leave a multicast group, they can either silently leave, or they can send a leave message. When the switch receives a leave message from a host, it sends out a MAC-based general query to determine if any other devices connected to that interface are interested in traffic for the specific multicast group. The switch then updates the forwarding table for that MAC group so that only those hosts interested in receiving multicast traffic for the group are listed in the forwarding table. If the router receives no reports from a VLAN, it removes the group for the VLAN from its IGMP cache.

## Immediate-Leave Processing

Immediate Leave is only supported with IGMPv2 hosts.

The switch uses IGMP snooping Immediate-Leave processing to remove from the forwarding table an interface that sends a leave message without the switch sending MAC-based general queries to the interface. The VLAN interface is pruned from the multicast tree for the multicast group specified in the original leave message. Immediate-Leave processing ensures optimal bandwidth management for all hosts on a switched network, even when multiple multicast groups are simultaneously in use.



Note

---

You should only use the Immediate-Leave processing feature on VLANs where a single host is connected to each port. If Immediate Leave is enabled in VLANs where more than one host is connected to a port, some hosts might inadvertently be dropped.

---

## IGMP Report Suppression



Note

---

IGMP report suppression is supported only when the multicast query has IGMPv1 and IGMPv2 reports. This feature is not supported when the query includes IGMPv3 reports.

---

The switch uses IGMP report suppression to forward only one IGMP report per multicast router query to multicast devices. When IGMP router suppression is enabled (the default), the switch sends the first IGMP report from all hosts for a group to all the multicast routers. The switch does not send the remaining IGMP reports for the group to the multicast routers. This feature prevents duplicate reports from being sent to the multicast devices.

If the multicast router query includes requests only for IGMPv1 and IGMPv2 reports, the switch forwards only the first IGMPv1 or IGMPv2 report from all hosts for a group to all the multicast routers.

If the multicast router query also includes requests for IGMPv3 reports, the switch forwards all IGMPv1, IGMPv2, and IGMPv3 reports for a group to the multicast devices.

If you disable IGMP report suppression, all IGMP reports are forwarded to the multicast routers.

## Source-Only Networks

In a source-only network, switch ports are connected to multicast source ports and multicast router ports. The switch ports are not connected to hosts that send IGMP join or leave messages.

The switch learns about IP multicast groups from the IP multicast data stream by using the source-only learning method. The switch forwards traffic only to the multicast router ports.

The default learning method is IP multicast-source-only learning. You can disable IP multicast-source-only learning by using the **no ip igmp snooping source-only-learning** global configuration command.

By default, the switch ages out forwarding-table entries that were learned by the source-only learning method and that are not in use. If the aging time is too long or is disabled, the forwarding table is filled with unused entries that the switch learned by using source-only learning or by using the IGMP join messages. When the switch receives traffic for new IP multicast groups, it floods the packet to all ports in the same VLAN. This unnecessary flooding can impact switch performance.

If aging is disabled and you want to delete multicast addresses that the switch learned by using source-only learning, re-enable aging of the forwarding-table entries. The switch can now age out the multicast addresses that were learned by the source-only learning method and that are not in use.

## Configuring IGMP Snooping

IGMP snooping allows switches to examine IGMP packets and make forwarding decisions based on their content.

These sections describe how to configure IGMP snooping:

- [Default IGMP Snooping Configuration, page 16-6](#)
- [Enabling or Disabling IGMP Snooping, page 16-7](#)
- [Setting the Snooping Method, page 16-7](#)
- [Configuring a Multicast Router Port, page 16-8](#)
- [Configuring a Host Statically to Join a Group, page 16-9](#)
- [Enabling IGMP Immediate-Leave Processing, page 16-10](#)
- [Disabling IP Multicast-Source-Only Learning, page 16-11](#)
- [Configuring the Aging Time, page 16-12](#)

## Default IGMP Snooping Configuration

Table 16-3 shows the default IGMP snooping configuration.

**Table 16-3 Default IGMP Snooping Configuration**

Feature	Default Setting
IGMP snooping	Enabled globally and per VLAN.
Multicast routers	None configured.
Multicast router learning (snooping) method	PIM-DVMRP.
IGMP snooping Immediate Leave	Disabled.
Static groups	None configured.
IP multicast-source-only learning	Enabled.
Aging forward-table entries (when source-only learning is enabled)	Enabled. The default is 600 seconds (10 minutes).
IGMP report suppression	Enabled.

## Enabling or Disabling IGMP Snooping

By default, IGMP snooping is globally enabled on the switch. When globally enabled or disabled, it is also enabled or disabled in all existing VLAN interfaces. IGMP snooping is by default enabled on all VLANs, but can be enabled and disabled on a per-VLAN basis.

Global IGMP snooping overrides the VLAN IGMP snooping. If global snooping is disabled, you cannot enable VLAN snooping. If global snooping is enabled, you can enable or disable VLAN snooping.

Beginning in privileged EXEC mode, follow these steps to globally enable IGMP snooping on the switch:

	Command	Purpose
Step 1	<b>configure terminal</b>	Enter global configuration mode.
Step 2	<b>ip igmp snooping</b>	Globally enable IGMP snooping in all existing VLAN interfaces.
Step 3	<b>end</b>	Return to privileged EXEC mode.
Step 4	<b>copy running-config startup-config</b>	(Optional) Save your entries in the configuration file.

To globally disable IGMP snooping on all VLAN interfaces, use the **no ip igmp snooping** global configuration command.

Beginning in privileged EXEC mode, follow these steps to enable IGMP snooping on a VLAN interface:

	Command	Purpose
Step 1	<b>configure terminal</b>	Enter global configuration mode.
Step 2	<b>ip igmp snooping vlan <i>vlan-id</i></b>	Enable IGMP snooping on the VLAN interface.
Step 3	<b>end</b>	Return to privileged EXEC mode.
Step 4	<b>copy running-config startup-config</b>	(Optional) Save your entries in the configuration file.

To disable IGMP snooping on a VLAN interface, use the **no ip igmp snooping vlan *vlan-id*** global configuration command for the specified VLAN number.

## Setting the Snooping Method

Multicast-capable router ports are added to the forwarding table for every Layer 2 multicast entry. The switch learns of such ports through one of these methods:

- Snooping on IGMP queries, Protocol Independent Multicast (PIM) packets, and Distance Vector Multicast Routing Protocol (DVMRP) packets
- Listening to Cisco Group Management Protocol (CGMP) packets from other routers
- Statically connecting to a multicast router port with the **ip igmp snooping mrouter** global configuration command

You can configure the switch either to snoop on IGMP queries and PIM/DVMRP packets or to listen to CGMP self-join or proxy-join packets. By default, the switch snoops on PIM/DVMRP packets on all VLANs. To learn of multicast router ports through only CGMP packets, use the **ip igmp snooping vlan *vlan-id* mrouter learn cgmp** global configuration command. When this command is entered, the router

listens to only CGMP self-join and CGMP proxy-join packets and no other CGMP packets. To learn of multicast router ports through only PIM-DVMRP packets, use the **ip igmp snooping vlan *vlan-id* mrouter learn pim-dvmrp** global configuration command.

Beginning in privileged EXEC mode, follow these steps to alter the method in which a VLAN interface dynamically accesses a multicast router:

	Command	Purpose
Step 1	<b>configure terminal</b>	Enter global configuration mode.
Step 2	<b>ip igmp snooping vlan <i>vlan-id</i> mrouter learn {cgmp   pim-dvmrp}</b>	Enable IGMP snooping on a VLAN. The VLAN ID range is 1 to 1005. Specify the multicast router learning method: <ul style="list-style-type: none"> <li>• <b>cgmp</b>—Listen for CGMP packets. This method is useful for reducing control traffic.</li> <li>• <b>pim-dvmrp</b>—Snoop on IGMP queries and PIM-DVMRP packets. This is the default.</li> </ul>
Step 3	<b>end</b>	Return to privileged EXEC mode.
Step 4	<b>show ip igmp snooping</b>	Verify the configuration.
Step 5	<b>copy running-config startup-config</b>	(Optional) Save your entries in the configuration file.

This example shows how to configure IGMP snooping to use CGMP packets as the learning method:

```
Switch# configure terminal
Switch(config)# ip igmp snooping vlan 1 mrouter learn cgmp
Switch(config)# end
Switch# show ip igmp snooping vlan 1
Global IGMP Snooping configuration:
-----
IGMP snooping                :Enabled
IGMPv3 snooping (minimal)    :Enabled
Report suppression           :Enabled
TCN solicit query            :Disabled
TCN flood query count        :2

Vlan 1:
-----
IGMP snooping                :Enabled
Immediate leave               :Disabled
Multicast router learning mode :pim-dvmrp
Source only learning age timer :10
CGMP interoperability mode     :IGMP_ONLY
```

To return to the default learning method, use the **no ip igmp snooping vlan *vlan-id* mrouter learn cgmp** global configuration command.

## Configuring a Multicast Router Port

To add a multicast router port (add a static connection to a multicast router), use the **ip igmp snooping vlan mrouter** global configuration command on the switch.

Beginning in privileged EXEC mode, follow these steps to enable a static connection to a multicast router:

	Command	Purpose
Step 1	<b>configure terminal</b>	Enter global configuration mode.
Step 2	<b>ip igmp snooping vlan <i>vlan-id</i> mrouter interface <i>interface-id</i></b>	Specify the multicast router VLAN ID and specify the interface to the multicast router. For the VLAN ID, the range is 1 to 1005.
Step 3	<b>end</b>	Return to privileged EXEC mode.
Step 4	<b>show ip igmp snooping mrouter [vlan <i>vlan-id</i>]</b>	Verify that IGMP snooping is enabled on the VLAN interface.
Step 5	<b>copy running-config startup-config</b>	(Optional) Save your entries in the configuration file.

To remove a multicast router port from the VLAN, use the **no ip igmp snooping vlan *vlan-id* mrouter interface *interface-id*** global configuration command.

This example shows how to enable a static connection to a multicast router and verify the configuration:

```
Switch# configure terminal
Switch(config)# ip igmp snooping vlan 200 mrouter interface gigabitethernet0/1
Switch(config)# end
Switch# show ip igmp snooping mrouter vlan 200
vlan          ports
-----+-----
  200          Gi0/1(static)
```

## Configuring a Host Statically to Join a Group

Hosts or Layer 2 ports normally join multicast groups dynamically, but you can also statically configure a host on an interface.

Beginning in privileged EXEC mode, follow these steps to add a Layer 2 port as a member of a multicast group:

	Command	Purpose
Step 1	<b>configure terminal</b>	Enter global configuration mode
Step 2	<b>ip igmp snooping vlan <i>vlan-id</i> static mac-address interface <i>interface-id</i></b>	Statically configure a Layer 2 port as a member of a multicast group: <ul style="list-style-type: none"> <li>• <i>vlan-id</i> is the multicast group VLAN ID.</li> <li>• <i>mac-address</i> is the group MAC address.</li> <li>• <i>interface-id</i> is the member port.</li> </ul>
Step 3	<b>end</b>	Return to privileged EXEC mode.
Step 4	<b>show ip igmp snooping mrouter vlan <i>vlan-id</i></b> or <b>show mac address-table multicast vlan <i>vlan-id</i></b>	Verify that the member port is a member of the VLAN multicast group. Verify the member port and the MAC address
Step 5	<b>copy running-config startup-config</b>	(Optional) Save your entries in the configuration file.

To remove the Layer 2 port from the multicast group, use the **no ip igmp snooping vlan *vlan-id* static mac-address interface *interface-id*** global configuration command.

This example shows how to statically configure a host on an interface and verify the configuration:

```
Switch# configure terminal
Switch(config)# ip igmp snooping vlan 1 static 0100.5e00.0203 interface gigabitethernet0/1
Switch(config)# end
Switch# show mac address-table multicast vlan 1
Vlan    Mac Address          Type    Ports
----    -
1       0100.5e00.0203      USER   Gi0/1
```

## Enabling IGMP Immediate-Leave Processing

When you enable IGMP Immediate-Leave processing, the switch immediately removes a port when it detects an IGMP version 2 leave message on that port. You should use the Immediate-Leave feature only when there is a single receiver present on every port in the VLAN.

Immediate Leave is supported with only IGMP version 2 hosts.

Beginning in privileged EXEC mode, follow these steps to enable IGMP Immediate-Leave processing:

	Command	Purpose
Step 1	<b>configure terminal</b>	Enter global configuration mode
Step 2	<b>ip igmp snooping vlan <i>vlan-id</i> immediate-leave</b>	Enable IGMP Immediate-Leave processing on the VLAN interface.
Step 3	<b>end</b>	Return to privileged EXEC mode.
Step 4	<b>show ip igmp snooping vlan <i>vlan-id</i></b>	Verify that Immediate Leave is enabled on the VLAN.
Step 5	<b>copy running-config startup-config</b>	(Optional) Save your entries in the configuration file.

To disable IGMP Immediate-Leave on a VLAN, use the **no ip igmp snooping vlan *vlan-id* immediate-leave** global configuration command.

This example shows how to enable IGMP immediate-leave processing on VLAN 130:

```
Switch# configure terminal
Switch(config)# ip igmp snooping vlan 130 immediate-leave
Switch(config)# end
```

## Disabling IGMP Report Suppression

IGMP report suppression is enabled by default. When it is enabled, the switch forwards only one IGMP report per multicast router query. When report suppression is disabled, all IGMP reports are forwarded to the multicast routers.



### Note

IGMP report suppression is supported only when the multicast query has IGMPv1 and IGMPv2 reports. This feature is not supported when the query includes IGMPv3 reports.

Beginning in privileged EXEC mode, follow these steps to disable IGMP report suppression:

	Command	Purpose
Step 1	<b>configure terminal</b>	Enter global configuration mode.
Step 2	<b>no ip igmp snooping report-suppression</b>	Disable IGMP report suppression.
Step 3	<b>end</b>	Return to privileged EXEC mode.
Step 4	<b>show ip igmp snooping</b>	Verify that IGMP report suppression is disabled.
Step 5	<b>copy running-config startup-config</b>	(Optional) Save your entries in the configuration file.

To re-enable IGMP report suppression, use the **ip igmp snooping report-suppression** global configuration command.

## Disabling IP Multicast-Source-Only Learning

The IP multicast-source-only learning method is enabled by default. The switch learns the IP multicast group from the IP multicast data stream and only forwards traffic to the multicast router ports.

If IP multicast-source-only learning is disabled by using the **ip igmp snooping source-only-learning** global configuration command, the switch floods unknown multicast traffic to the VLAN and sends the traffic to the CPU until the traffic becomes known. When the switch receives an IGMP report from a host for a particular multicast group, the switch forwards traffic from this multicast group only to the multicast router ports.



### Note

We strongly recommend that you do not disable IP multicast-source-only learning. IP multicast-source-only learning should be disabled only if your network is not composed of IP multicast-source-only networks and if disabling this learning method improves the network performance.

Beginning in privileged EXEC mode, follow these steps to disable IP multicast-source-only learning:

	Command	Purpose
Step 1	<b>configure terminal</b>	Enter global configuration mode
Step 2	<b>no ip igmp snooping source-only-learning</b>	Disable IP multicast-source-only learning.
Step 3	<b>end</b>	Return to privileged EXEC mode.
Step 4	<b>show running-config   include source-only-learning</b>	Verify that IP multicast-source-only learning is disabled.
Step 5	<b>copy running-config startup-config</b>	(Optional) Save your entries in the configuration file.

To enable IP multicast-source-only learning, use the **ip igmp snooping source-only-learning** global configuration command.

This example shows how to disable IP multicast-source-only learning and verify the configuration:

```
Switch# configure terminal
Switch(config)# no ip igmp snooping source-only-learning
Switch(config)# end
Switch# show running-config | include source-only-learning
```

```

Current configuration : 1972 bytes
!
version 12.1
no service pad
service timestamps debug uptime
service timestamps log uptime
no service password-encryption
!
hostname Switch
!
enable password my_password
!
ip subnet-zero
no ip igmp snooping source-only-learning
!
!
spanning-tree extend system-id
no spanning-tree vlan 1
!
!
interface FastEthernet0/1
 no ip address
!
<output truncated>

```

## Configuring the Aging Time

You can set the aging time for forwarding-table entries that the switch learns by using the IP multicast-source-only learning method.

Beginning in privileged EXEC mode, follow these steps to configure the aging time:

	Command	Purpose
Step 1	<b>configure terminal</b>	Enter global configuration mode
Step 2	<b>ip igmp snooping source-only-learning age-timer <i>time</i></b>	Set the aging time. The range is from 0 to 2880 seconds. The default is 600 seconds (10 minutes).
Step 3	<b>end</b>	Return to privileged EXEC mode.
Step 4	<b>show running-config   include source-only-learning</b>	Verify the aging time.
Step 5	<b>copy running-config startup-config</b>	(Optional) Save your entries in the configuration file.

To disable the aging of the forwarding table entries, enter the **ip igmp snooping source-only-learning age-timer 0** global configuration command.

If you disable source-only learning by using the **no ip igmp snooping source-only learning** global configuration command and the aging time is enabled, it has no effect on the switch.

## Displaying IGMP Snooping Information

You can display IGMP snooping information for dynamically learned and statically configured router ports and VLAN interfaces. You can also display MAC address multicast entries for a VLAN configured for IGMP snooping.

To display IGMP snooping information, use one or more of the privileged EXEC commands in [Table 16-4](#).

**Table 16-4** Commands for Displaying IGMP Snooping Information

Command	Purpose
<b>show ip igmp snooping</b> [ <b>vlan</b> <i>vlan-id</i> ]	Display the snooping configuration information for all VLANs on the switch or for a specified VLAN.  (Optional) Enter <b>vlan</b> <i>vlan-id</i> to display information for a single VLAN.
<b>show ip igmp snooping group</b> [ <b>vlan</b> <i>vlan-id</i> ]	Display information about the IGMP multicast groups, the compatibility mode, and the ports that are associated with each group.  (Optional) Enter <b>vlan</b> <i>vlan-id</i> to display information for a single VLAN.
<b>show ip igmp snooping mrouter</b> [ <b>vlan</b> <i>vlan-id</i> ]	Display information on dynamically learned and manually configured multicast router interfaces.  <b>Note</b> When you enable IGMP snooping, the switch automatically learns the interface to which a multicast router is connected. These are dynamically learned interfaces.  (Optional) Enter <b>vlan</b> <i>vlan-id</i> to display information for a single VLAN.
<b>show ip igmp snooping querier</b> [ <b>vlan</b> <i>vlan-id</i> ]	Display information about the IGMP version that an interface supports.  (Optional) Enter <b>vlan</b> <i>vlan-id</i> to display information for a single VLAN.
<b>show mac address-table multicast</b> [ <b>vlan</b> <i>vlan-id</i> ] [ <b>user</b>   <b>igmp-snooping</b> ] [ <b>count</b> ]	Display the Layer 2 MAC address table entries for a VLAN. The keywords are all optional and limit the display as shown: <ul style="list-style-type: none"> <li>• <b>vlan</b> <i>vlan-id</i>—Displays only the specified multicast group VLAN.</li> <li>• <b>user</b>—Displays only the user-configured multicast entries.</li> <li>• <b>igmp-snooping</b>—Displays only entries learned through IGMP snooping.</li> <li>• <b>count</b>—Displays only the total number of entries for the selected criteria, not the actual entries.</li> </ul>

For more information about the keywords and options in these commands, refer to the command reference for this release.

For examples of output from the commands in [Table 16-4](#), refer to the command reference for this release.

# Understanding Multicast VLAN Registration

Multicast VLAN Registration (MVR) is designed for applications using wide-scale deployment of multicast traffic across an Ethernet ring-based service provider network (for example, the broadcast of multiple television channels over a service-provider network). MVR allows a subscriber on a port to subscribe and unsubscribe to a multicast stream on the network-wide multicast VLAN. It allows the single multicast VLAN to be shared in the network while subscribers remain in separate VLANs. MVR provides the ability to continuously send multicast streams in the multicast VLAN, but to isolate the streams from the subscriber VLANs for bandwidth and security reasons.

MVR assumes that subscriber ports subscribe and unsubscribe (join and leave) these multicast streams by sending out IGMP join and leave messages. These messages can originate from an IGMP version-2-compatible host with an Ethernet connection. Although MVR operates on the underlying mechanism of IGMP snooping, the two features operate independently of each other. One can be enabled or disabled without affecting the behavior of the other feature. However, if IGMP snooping and MVR are both enabled, MVR reacts only to join and leave messages from multicast groups configured under MVR. Join and leave messages from all other multicast groups are managed by IGMP snooping.

The switch CPU identifies the MVR IP multicast streams and their associated MAC addresses in the switch forwarding table, intercepts the IGMP messages, and modifies the forwarding table to include or remove the subscriber as a receiver of the multicast stream, even though the receivers might be in a different VLAN from the source. This forwarding behavior selectively allows traffic to cross between different VLANs.

The switch has these modes of MVR operation: dynamic and compatible.

- When operating in MVR dynamic mode, the switch performs standard IGMP snooping. IGMP information packets are sent to the switch CPU, but multicast data packets are not sent to the CPU. Dynamic mode allows the multicast router to run normally because the switch sends the IGMP join messages to the router, and the router forwards multicast streams for a particular group to an interface only if it has received a join message from the interface for the group. Receiver ports are treated as members of the multicast VLAN for MVR multicast control and data traffic. IGMP reports for MVR groups are sent out source ports in the multicast VLAN.
- When in MVR compatible mode, MVR on the Catalyst 2940 switch interoperates with MVR on Catalyst 3500 XL and Catalyst 2900 XL switches. It works the same as dynamic mode for all multicast data packets and IGMP query and leave packets. However, received IGMP report packets for MVR groups are not sent out on the multicast VLAN source ports. In contrast to dynamic mode, the switch does not send join messages to the router. The router must be statically configured for the interface to receive the multicast stream. Therefore, in this mode, MVR does not support dynamic membership joins on source ports.



Note

---

IGMPv3 join and leave messages are not supported on switches running MVR.

---

## Using MVR in a Multicast Television Application

In a multicast television application, a PC or a television with a set-top box can receive the multicast stream. Multiple set-top boxes or PCs can be connected to one subscriber port, which is a switch port configured as an MVR receiver port. See [Figure 16-3](#). DHCP assigns an IP address to the set-top box or the PC. When a subscriber selects a channel, the set-top box or PC sends an IGMP report to the S1 switch to join the appropriate multicast. If the IGMP report matches one of the configured multicast MAC addresses, the switch CPU modifies the hardware address table to include this receiver port and VLAN

as a forwarding destination of the specified multicast stream when it is received from the multicast VLAN. Uplink ports that send and receive multicast data to and from the multicast VLAN are called MVR source ports.

When a subscriber changes channels or turns off the television, the set-top box sends an IGMP leave message for the multicast stream. The switch CPU sends an IGMP group-specific query through the receiver port VLAN. If there is another set-top box in the VLAN still subscribing to this group, that set-top box must respond within the maximum response time. If the CPU does not receive a response, it eliminates the receiver port as a forwarding destination for this group.

If the Immediate-Leave feature is enabled on a receiver port, the port leaves a multicast group more quickly. Without Immediate Leave, when the switch receives an IGMP leave message from a subscriber on a receiver port, it sends out an IGMP query on that port and waits for IGMP group membership reports. If no reports are received in a configured time period, the receiver port is removed from multicast group membership. With Immediate Leave, an IGMP query is not sent from the receiver port on which the IGMP leave was received. As soon as the leave message is received, the receiver port is removed from multicast group membership, which speeds up leave latency. Enable the Immediate Leave feature only on receiver ports to which a single receiver device is connected.

Figure 16-3 Multicast VLAN Registration Example

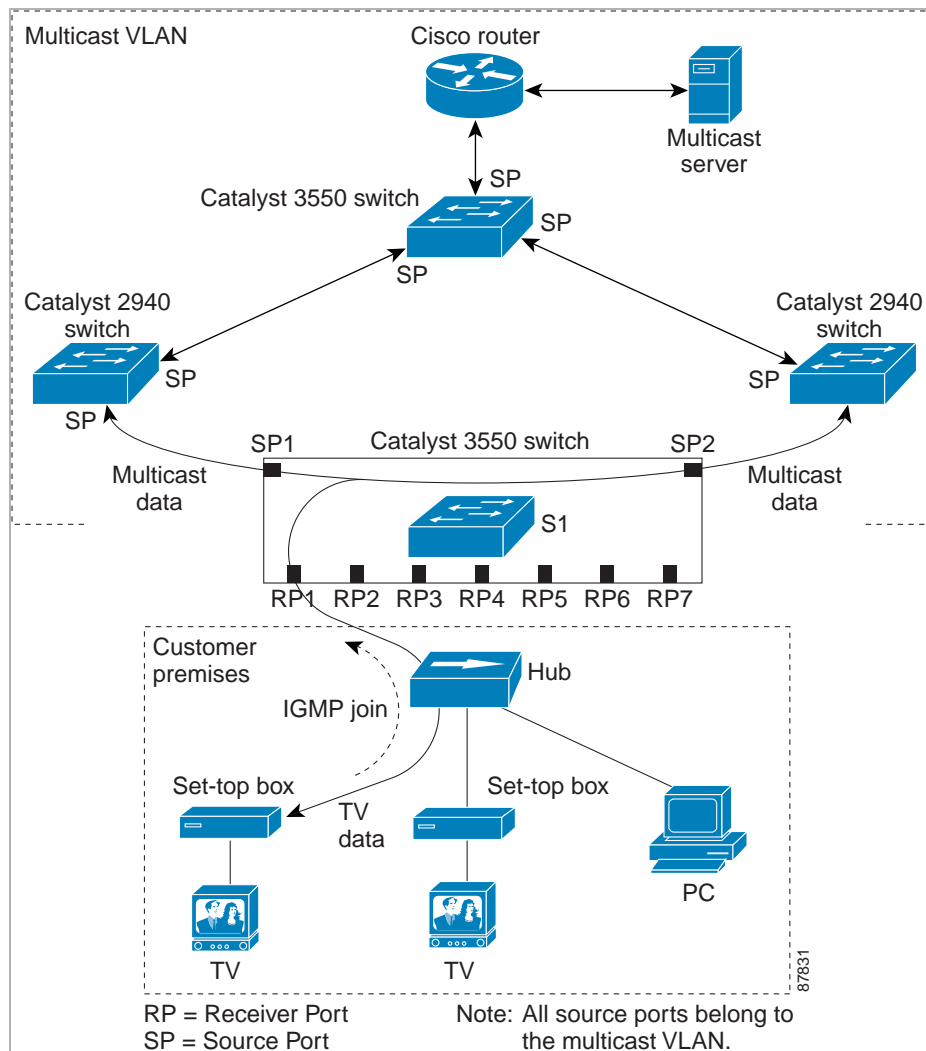

MVR eliminates the need to duplicate television-channel multicast traffic for subscribers in each VLAN. Multicast traffic for all channels is only sent around the VLAN trunk once—only on the multicast VLAN. Although the IGMP leave and join message in the VLAN to which the subscriber port is assigned. These messages dynamically register for streams of multicast traffic in the multicast VLAN on the Layer 3 device. The access layer switch (S1 switch) modifies the forwarding behavior to allow the traffic to be forwarded from the multicast VLAN to the subscriber port in a different VLAN, selectively allowing traffic to cross between two VLANs.

IGMP reports are sent to the same MAC addresses as the multicast data. The S1 CPU must capture all IGMP join and leave messages from receiver ports and forward them to the multicast VLAN of the source (uplink) port.

## Configuring MVR

These sections include basic MVR configuration information:

- [Default MVR Configuration, page 16-16](#)
- [MVR Configuration Guidelines and Limitations, page 16-17](#)
- [Configuring MVR Global Parameters, page 16-17](#)
- [Configuring MVR Interfaces, page 16-18](#)

## Default MVR Configuration

[Table 16-5](#) shows the default MVR configuration.

**Table 16-5** *Default MVR Configuration*

Feature	Default Setting
MVR	Disabled globally and per interface
Multicast addresses	None configured
Query response time	0.5 second
Multicast VLAN	VLAN 1
Mode	Compatible
Interface (per port) default	Neither a receiver nor a source port
Immediate Leave	Disabled on all ports

## MVR Configuration Guidelines and Limitations

Follow these guidelines when configuring MVR:

- Receiver ports cannot be trunk ports. Receiver ports on a switch can be in different VLANs, but should not belong to the multicast VLAN.
- The maximum number of multicast entries that can be configured on a switch (that is, the maximum number of television channels that can be received) is 256.
- Each channel is one multicast stream destined for a unique IP multicast address. These IP addresses cannot alias between themselves or with the reserved IP multicast addresses (in the range 224.0.0.xxx).
- MVR does not support IGMPv3 messages.



### Note

For complete syntax and usage information for the commands used in this section, refer to the command reference for this release.

## Configuring MVR Global Parameters

You do not need to set the optional MVR parameters if you choose to use the default settings. If you do want to change the default parameters (except for the MVR VLAN), you must first enable MVR.

Beginning in privileged EXEC mode, follow these steps to configure MVR parameters:

	Command	Purpose
Step 1	<b>configure terminal</b>	Enter global configuration mode.
Step 2	<b>mvr</b>	Enable MVR on the switch.
Step 3	<b>mvr group</b> <i>ip-address</i> [ <i>count</i> ]	Configure an IP multicast address on the switch or use the <i>count</i> parameter to configure a contiguous series of MVR group addresses (the range for <i>count</i> is 1 to 256; the default is 1). Any multicast data sent to this address is sent to all source ports on the switch and all receiver ports that have elected to receive data on that multicast address. Each multicast address would correspond to one television channel.  <b>Note</b> Each IP address translates to a multicast 48-bit MAC address. If an IP address being configured translates (aliases) to a previously configured MAC address or to any reserved multicast MAC addresses, the command fails.
Step 4	<b>mvr querytime</b> <i>value</i>	(Optional) Define the maximum time to wait for IGMP report memberships on a receiver port before removing the port from multicast group membership. The value is in units of tenths of a second. The range is from 1 to 100 and the default is 5 tenths or one-half second.
Step 5	<b>mvr vlan</b> <i>vlan-id</i>	(Optional) Specify the VLAN in which multicast data is received; all source ports must belong to this VLAN. The VLAN range is 1 to 1005. The default is VLAN 1.

	Command	Purpose
Step 6	<b>mvr mode {dynamic   compatible}</b>	(Optional) Specify the MVR mode of operation: <ul style="list-style-type: none"> <li>• <b>dynamic</b>—Allows dynamic MVR membership on source ports.</li> <li>• <b>compatible</b>—Is compatible with Catalyst 3500 XL and Catalyst 2900 XL switches and does not support IGMP dynamic joins on source ports.</li> </ul> The default is <b>compatible</b> mode.
Step 7	<b>end</b>	Return to privileged EXEC mode.
Step 8	<b>show mvr</b> or <b>show mvr members</b>	Verify the configuration.
Step 9	<b>copy running-config startup-config</b>	(Optional) Save your entries in the configuration file.

To return the switch to its default settings, use the **no mvr [mode | group ip-address | querytime | vlan]** global configuration commands.

This example shows how to enable MVR, configure the MVR group address, set the query time to 1 second (10 tenths), specify the MVR multicast VLAN as VLAN 22, set the MVR mode as dynamic, and verify the results:

```
Switch(config)# mvr
Switch(config)# mvr group 228.1.23.4
Switch(config)# mvr querytime 10
Switch(config)# mvr vlan 22
Switch(config)# mvr mode dynamic
Switch(config)# end
Switch# show mvr
MVR Running: TRUE
MVR multicast vlan: 22
MVR Max Multicast Groups: 256
MVR Current multicast groups: 1
MVR Global query response time: 10 (tenths of sec)
MVR Mode: dynamic
```

You can use the **show mvr members** privileged EXEC command to verify the MVR multicast group addresses on the switch.

## Configuring MVR Interfaces

Beginning in privileged EXEC mode, follow these steps to configure MVR interfaces:

	Command	Purpose
Step 1	<b>configure terminal</b>	Enter global configuration mode.
Step 2	<b>mvr</b>	Enable MVR on the switch.
Step 3	<b>interface interface-id</b>	Enter interface configuration mode, and enter the type and number of the port to configure; for example, enter <b>gi0/1</b> or <b>gigabitethernet 0/1</b> for Gigabit Ethernet port 1.

	Command	Purpose
Step 4	<b>mvr type</b> {source   receiver}	<p>Configure an MVR port as one of these:</p> <ul style="list-style-type: none"> <li>• <b>source</b>—Configure uplink ports that receive and send multicast data as source ports. Subscribers cannot be directly connected to source ports. All source ports on a switch belong to the single multicast VLAN.</li> <li>• <b>receiver</b>—Configure a port as a receiver port if it is a subscriber port and should only receive multicast data. It does not receive data unless it becomes a member of the multicast group, either statically or by using IGMP leave and join messages. Receiver ports cannot belong to the multicast VLAN.</li> </ul> <p>The default configuration is as a non-MVR port. If you attempt to configure a non-MVR port with MVR characteristics, the operation fails.</p>
Step 5	<b>mvr vlan</b> <i>vlan-id</i> <b>group</b> <i>ip-address</i>	<p>(Optional) Statically configure a port to receive multicast traffic sent to the multicast VLAN and the IP multicast address. A port statically configured as a member of a group remains a member of the group until statically removed.</p> <p><b>Note</b> In compatible mode, this command applies to only receiver ports. In dynamic mode, it applies to receiver ports and source ports.</p> <p>Receiver ports can also dynamically join multicast groups by using IGMP join and leave messages.</p>
Step 6	<b>mvr immediate</b>	<p>(Optional) Enable the Immediate Leave feature of MVR on the port.</p> <p><b>Note</b> This command applies to only receiver ports and should only be enabled on receiver ports to which a single receiver device is connected.</p>
Step 7	<b>end</b>	Return to privileged EXEC mode.
Step 8	<b>show mvr</b>  <b>show mvr interface</b>  or  <b>show mvr members</b>	Verify the configuration.
Step 9	<b>copy running-config startup-config</b>	(Optional) Save your entries in the configuration file.

To return the interface to its default settings, use the **no mvr [type | immediate | vlan *vlan-id* | group]** interface configuration commands.

This example shows how to configure Gigabit Ethernet port 0/1 as a receiver port, statically configure the port to receive multicast traffic sent to the multicast group address, configure Immediate Leave on the interface, and verify the results.

```
Switch(config)# mvr
Switch(config)# interface gigabitethernet0/1
Switch(config-if)# mvr type receiver
Switch(config-if)# mvr vlan 22 group 228.1.23.4
Switch(config-if)# mvr immediate
Switch(config)# end
Switch# show mvr interface gigabitethernet0/1
Type: RECEIVER Status: ACTIVE Immediate Leave: ENABLED
```

This is an example of output from the **show mvr interface** privileged EXEC command when the **member** keyword is included:

```
Switch# show mvr interface fastethernet0/2 members
224.0.1.1          DYNAMIC ACTIVE
```

## Displaying MVR Information

You can display MVR information for the switch or for a specified interface.

Beginning in privileged EXEC mode, use the commands in [Table 16-6](#) to display MVR configuration:

**Table 16-6** Commands for Displaying MVR Information

<b>show mvr</b>	Displays MVR status and values for the switch—whether MVR is enabled or disabled, the multicast VLAN, the maximum (256) and current (0 through 256) number of multicast groups, the query response time, and the MVR mode.
<b>show mvr interface</b> [ <i>interface-id</i> ] <b>[members [vlan <i>vlan-id</i>]]</b>	Displays all MVR interfaces and their MVR configurations.  When a specific interface is entered, displays this information: <ul style="list-style-type: none"> <li>• Type—Receiver or Source</li> <li>• Status—One of these: <ul style="list-style-type: none"> <li>– Active means the port is part of a VLAN.</li> <li>– Up/Down means that the port is forwarding or nonforwarding.</li> <li>– Inactive means that the port is not part of any VLAN.</li> </ul> </li> <li>• Immediate Leave—Enabled or Disabled</li> </ul> If the <b>members</b> keyword is entered, displays all multicast group members on this port or, if a VLAN identification is entered, all multicast group members on the VLAN. The VLAN ID range is 1 to 1005.
<b>show mvr members</b> [ <i>ip-address</i> ]	Displays all receiver and source ports that are members of any IP multicast group or the specified IP multicast group IP address.

This is an example of output from the **show mvr** privileged EXEC command:

```
Switch# show mvr
MVR Running: TRUE
MVR multicast vlan: 1
MVR Max Multicast Groups: 256
MVR Current multicast groups: 256
MVR Global query response time: 5 (tenths of sec)
MVR Mode: compatible
```

This is an example of output from the **show mvr interface** privileged EXEC command:

```
Switch# show mvr interface
Port      Type           Status          Immediate Leave
----      -
Fa0/1     SOURCE         ACTIVE/UP       DISABLED
Fa0/2     SOURCE         ACTIVE/UP       DISABLED
Fa0/3     SOURCE         ACTIVE/DOWN     DISABLED
Fa0/5     SOURCE         ACTIVE/DOWN     DISABLED
```

This is an example of output from the **show mvr interface** privileged EXEC command for a specified interface:

```
Switch# show mvr interface fastethernet0/2
224.0.1.1          DYNAMIC ACTIVE
```

This is an example of output from the **show mvr interface** privileged EXEC command when the **members** keyword is included:

```
Switch# show mvr interface fastethernet0/2 members
224.0.1.1          DYNAMIC ACTIVE
```

This is an example of output from the **show mvr members** privileged EXEC command:

```
Switch# show mvr members
MVR Group IP      Status           Members
-----
224.0.1.1         ACTIVE          Fa0/1 (s) , Fa0/2 (d)
224.0.1.2         ACTIVE          Fa0/1 (s)
224.0.1.3         ACTIVE          Fa0/1 (s)
224.0.1.4         ACTIVE          Fa0/1 (s)
224.0.1.5         ACTIVE          Fa0/1 (s)
<output truncated>
```

## Configuring IGMP Filtering and Throttling

In some environments, for example, metropolitan or multiple-dwelling unit (MDU) installations, you might want to control the set of multicast groups to which a user on a switch port can belong. You can control the distribution of multicast services, such as IP/TV, based on some type of subscription or service plan. You might also want to limit the number of multicast groups to which a user on a switch port can belong.

With the IGMP filtering feature, you can filter multicast joins on a per-port basis by configuring IP multicast profiles and associating them with individual switch ports. An IGMP profile can contain one or more multicast groups and specifies whether access to the group is permitted or denied. If an IGMP profile denying access to a multicast group is applied to a switch port, the IGMP join report requesting the stream of IP multicast traffic is dropped, and the port is not allowed to receive IP multicast traffic from that group. If the filtering action permits access to the multicast group, the IGMP report from the port is forwarded for normal processing.

IGMP filtering controls only group specific query and membership reports, including join and leave reports. It does not control general IGMP queries. IGMP filtering has no relationship with the function that directs the forwarding of IP multicast traffic. The filtering feature operates in the same manner whether CGMP or MVR is used to forward the multicast traffic.



**Note**

---

IGMPv3 join and leave messages are not supported on switches running IGMP filtering.

---

You can also set the maximum number of IGMP groups that a Layer 2 interface can join.

With the IGMP throttling feature, you can also set the maximum number of IGMP groups that a Layer 2 interface can join. If the maximum number of IGMP groups is set, the IGMP snooping forwarding table contains the maximum number of entries, and the interface receives an IGMP join report, you can configure an interface to drop the IGMP report or to remove a randomly selected multicast entry in the forwarding table and then to add the IGMP group in the report to the table.

These sections describe how to configure IGMP filtering and throttling:

- [Default IGMP Filtering and Throttling Configuration, page 16-22](#)
- [Configuring IGMP Profiles, page 16-22](#) (optional)
- [Applying IGMP Profiles, page 16-23](#) (optional)
- [Setting the Maximum Number of IGMP Groups, page 16-25](#) (optional)
- [Configuring the IGMP Throttling Action, page 16-25](#) (optional)

## Default IGMP Filtering and Throttling Configuration

[Table 16-7](#) shows the default IGMP filtering configuration.

*Table 16-7 Default IGMP Filtering Configuration*

Feature	Default Setting
IGMP filters	None applied
IGMP Maximum number of IGMP groups	No maximum set
IGMP profiles	None defined
IGMP profile action	Deny the range addresses

When the maximum number of groups is in forwarding table, the default IGMP throttling action is to deny the IGMP report. For configuration guidelines, see the [“Configuring the IGMP Throttling Action” section on page 16-25](#).

## Configuring IGMP Profiles

To configure an IGMP profile, use the **ip igmp profile** global configuration command with a profile number to create an IGMP profile and to enter IGMP profile configuration mode. From this mode, you can specify the parameters of the IGMP profile to be used for filtering IGMP join requests from a port. When you are in IGMP profile configuration mode, you can create the profile by using these commands:

- **deny**: Specifies that matching addresses are denied; this is the default condition.
- **exit**: Exits from igmp-profile configuration mode.
- **no**: Negates a command or sets its defaults.
- **permit**: Specifies that matching addresses are permitted.
- **range**: Specifies a range of IP addresses for the profile. You can enter a single IP address or a range with a start and an end address.

The default is for the switch to have no IGMP profiles configured. When a profile is configured, if neither the **permit** nor **deny** keyword is included, the default is to deny access to the range of IP addresses.

Beginning in privileged EXEC mode, follow these steps to create an IGMP profile:

	Command	Purpose
Step 1	<b>configure terminal</b>	Enter global configuration mode.
Step 2	<b>ip igmp profile</b> <i>profile number</i>	Enter IGMP profile configuration mode, and assign a number to the profile you are configuring. The range is from 1 to 4294967295.
Step 3	<b>permit   deny</b>	(Optional) Set the action to permit or deny access to the IP multicast address. If no action is configured, the default for the profile is to deny access.
Step 4	<b>range</b> <i>ip multicast address</i>	Enter the IP multicast address or range of IP multicast addresses to which access is being controlled. If entering a range, enter the low IP multicast address, a space, and the high IP multicast address.  You can use the <b>range</b> command multiple times to enter multiple addresses or ranges of addresses.
Step 5	<b>end</b>	Return to privileged EXEC mode.
Step 6	<b>show ip igmp profile</b> <i>profile number</i>	Verify the profile configuration.
Step 7	<b>copy running-config startup-config</b>	(Optional) Save your entries in the configuration file.

To delete a profile, use the **no ip igmp profile** *profile number* global configuration command.

To delete an IP multicast address or range of IP multicast addresses, use the **no range** *ip multicast address* IGMP profile configuration command.

This example shows how to create IGMP profile 4 allowing access to the single IP multicast address and how to verify the configuration. If the action was to deny (the default), it would not appear in the **show ip igmp profile** output display.

```
Switch(config)# ip igmp profile 4
Switch(config-igmp-profile)# permit
Switch(config-igmp-profile)# range 229.9.9.0
Switch(config-igmp-profile)# end
Switch# show ip igmp profile 4
IGMP Profile 4
    permit
    range 229.9.9.0 229.9.9.0
```

## Applying IGMP Profiles

To control access as defined in an IGMP profile, use the **ip igmp filter** interface configuration command to apply the profile to the appropriate interfaces. You can apply IGMP profiles to Layer 2 ports only. You cannot apply profiles to ports that belong to an EtherChannel port group. You can apply a profile to multiple interfaces, but each interface can only have one profile applied to it.

Beginning in privileged EXEC mode, follow these steps to apply an IGMP profile to a switch port:

	Command	Purpose
Step 1	<b>configure terminal</b>	Enter global configuration mode.
Step 2	<b>interface</b> <i>interface-id</i>	Enter interface configuration mode, and enter the physical interface to configure, for example <b>fastethernet0/3</b> . The interface must be a Layer 2 port that does not belong to an EtherChannel port group.
Step 3	<b>ip igmp filter</b> <i>profile number</i>	Apply the specified IGMP profile to the interface. The profile number can be from 1 to 4294967295.
Step 4	<b>end</b>	Return to privileged EXEC mode.
Step 5	<b>show running configuration interface</b> <i>interface-id</i>	Verify the configuration.
Step 6	<b>copy running-config startup-config</b>	(Optional) Save your entries in the configuration file.

To remove a profile from an interface, use the **no ip igmp filter** *profile number* interface configuration command.

This example shows how to apply IGMP profile 4 to an interface and verify the configuration.

```
Switch(config)# interface fastethernet0/8
Switch(config-if)# ip igmp filter 4
Switch(config-if)# end
Switch# show running-config interface fastethernet0/8
Building configuration...

Current configuration : 123 bytes
!
interface FastEthernet0/8
 no ip address
 shutdown
 snmp trap link-status
 ip igmp max-groups 25
 ip igmp filter 4
end
```

## Setting the Maximum Number of IGMP Groups

You can set the maximum number of IGMP groups that a Layer 2 interface can join by using the **ip igmp max-groups** interface configuration command. Use the **no** form of this command to set the maximum back to the default, which is no limit.

You can use this command on a logical EtherChannel interface but cannot use it on ports that belong to an EtherChannel port group.

Beginning in privileged EXEC mode, follow these steps to set the maximum number of IGMP groups in the forwarding table:

	Command	Purpose
Step 1	<b>configure terminal</b>	Enter global configuration mode.
Step 2	<b>interface</b> <i>interface-id</i>	Enter interface configuration mode, and enter the physical interface to configure, for example <b>gigabitethernet0/1</b> . The interface can be a Layer 2 port that does not belong to an EtherChannel group or a EtherChannel interface.
Step 3	<b>ip igmp max-groups</b> <i>number</i>	Set the maximum number of IGMP groups that the interface can join. The range is from 0 to 4294967294. The default is to have no maximum set.
Step 4	<b>end</b>	Return to privileged EXEC mode.
Step 5	<b>show running-configuration interface</b> <i>interface-id</i>	Verify the configuration.
Step 6	<b>copy running-config startup-config</b>	(Optional) Save your entries in the configuration file.

To remove the maximum group limitation and return to the default of no maximum, use the **no ip igmp max-groups** interface configuration command.

This example shows how to limit to 25 the number of IGMP groups that an interface can join.

```
Switch(config)# interface fastethernet0/4
Switch(config-if)# ip igmp max-groups 25
Switch(config-if)# end
```

## Configuring the IGMP Throttling Action

After you set the maximum number of IGMP groups that a Layer 2 interface can join, you can configure an interface to remove a randomly selected multicast entry in the forwarding table and to add the next IGMP group to it by using the **ip igmp max-groups action replace** interface configuration command. Use the **no** form of this command to return to the default, which is to drop the IGMP join report.

Follow these guidelines when configuring the IGMP throttling action:

- You can use this command on a logical EtherChannel interface but cannot use it on ports that belong to an EtherChannel port group.
- When the maximum group limitation is set to the default (no maximum), entering the **ip igmp max-groups action {deny | replace}** command has no effect.
- If you configure the throttling action and set the maximum group limitation after an interface has added multicast entries to the forwarding table, the forwarding-table entries are either aged out or removed, depending on the throttling action.

- If you configure the throttling action as **deny**, the entries that were previously in the forwarding table are not removed but are aged out. After these entries are aged out and the maximum number of entries is in the forwarding table, the switch drops the next IGMP report received on the interface.
- If you configure the throttling action as **replace**, the entries that were previously in the forwarding table are removed. When the maximum number of entries is in the forwarding table, the switch deletes a randomly selected entry and adds an entry for the next IGMP report received on the interface.

To prevent the switch from removing the forwarding-table entries, you can configure the IGMP throttling action before an interface adds entries to the forwarding table.

Beginning in privileged EXEC mode, follow these steps to configure the throttling action when the maximum number of entries is in the forwarding table:

	Command	Purpose
Step 1	<b>configure terminal</b>	Enter global configuration mode.
Step 2	<b>interface</b> <i>interface-id</i>	Enter interface configuration mode, and enter the physical interface to configure. The interface can be a Layer 2 port that does not belong to an EtherChannel group or an EtherChannel interface. The interface cannot be a trunk port.
Step 3	<b>ip igmp max-groups action</b> { <b>deny</b>   <b>replace</b> }	When an interface receives an IGMP report and the maximum number of entries is in the forwarding table, specify the action that the interface takes: <ul style="list-style-type: none"> <li>• <b>deny</b>—Drop the report.</li> <li>• <b>replace</b>—Remove a randomly selected multicast entry in the forwarding table, and add the IGMP group in the report.</li> </ul>
Step 4	<b>end</b>	Return to privileged EXEC mode.
Step 5	<b>show running-config interface</b> <i>interface-id</i>	Verify the configuration.
Step 6	<b>copy running-config startup-config</b>	(Optional) Save your entries in the configuration file.

To return to the default action of dropping the report, use the **no ip igmp max-groups action** interface configuration command.

This example shows how to configure an interface to remove a randomly selected multicast entry in the forwarding table and to add an IGMP group to the forwarding table if the maximum number of entries is in the table.

```
Switch(config)# interface gigabitethernet0/1
Switch(config-if)# ip igmp max-groups action replace
Switch(config-if)# end
```

## Displaying IGMP Filtering and Throttling Configuration

You can display IGMP profile characteristics, and you can display the IGMP profile and maximum group configuration for all interfaces on the switch or for a specified interface. You can also display the IGMP throttling configuration for all interfaces on the switch or for a specified interface.

Use the privileged EXEC commands in [Table 16-8](#) to display IGMP filtering and throttling configuration:

**Table 16-8** *Commands for Displaying IGMP Filtering and Throttling Configuration*

<b>show ip igmp profile</b> [ <i>profile number</i> ]	Displays the specified IGMP profile or all the IGMP profiles defined on the switch.
<b>show running-configuration</b> [ <b>interface</b> <i>interface-id</i> ]	Displays the configuration of the specified interface or the configuration of all interfaces on the switch, including (if configured) the maximum number of IGMP groups to which an interface can belong and the IGMP profile applied to the interface.

