



Connectors and Cables

This appendix describes the connectors, cables, and adapters that you use to connect the switch to other devices.

Connector Specifications

These sections describe the connectors used with the Catalyst 2940 switches and contains this information:

- [10/100 Ports, page B-1](#)
- [10/100/1000 Ports, page B-3](#)
- [100BASE-FX Port, page B-4](#)
- [SFP Module Slot, page B-4](#)
- [Console Port, page B-5](#)

10/100 Ports

The 10/100 Ethernet ports use standard RJ-45 connectors and Ethernet pinouts with internal crossovers, as shown by an **X** in the port label on the switch, as shown in [Figure B-1](#).

Figure B-1 Port Labels Showing Internal Crossovers

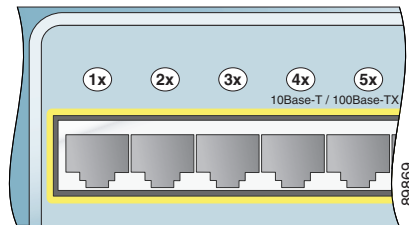

These ports have the transmit (TD) and receive (RD) signals internally crossed so that a twisted-pair straight-through cable and adapter can be attached to the port. [Figure B-2](#) shows the pinout.

Figure B-2 10/100 RJ-45 Pinouts

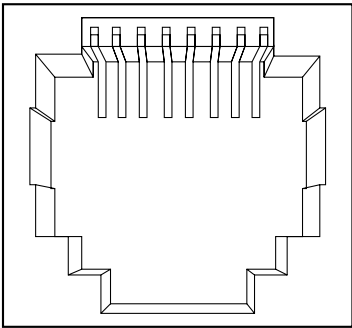
Pin	Label	1 2 3 4 5 6 7 8
1	RD+	
2	RD-	
3	TD+	
4	NC	
5	NC	
6	TD-	
7	NC	
8	NC	

When connecting 10/100 ports to other devices, such as servers, workstations, and routers, you can use a two or four twisted-pair, straight-through cable wired for 10BASE-T and 100BASE-TX. [Figure B-6](#) shows the two twisted-pair, straight-through cable schematics. [Figure B-8](#) shows the four twisted-pair, straight-through cable schematics.

When connecting the ports to other devices, such as switches or repeaters, you can use a two or four twisted-pair, crossover cable. [Figure B-7](#) shows the two twisted-pair, crossover cable schematics. [Figure B-9](#) shows the four twisted-pair, crossover cable schematics.

You can use Category 3, 4, or 5 cabling when connecting to 10BASE-T devices. You must use Category 5 cabling when connecting to 100BASE-TX devices.

**Note**

Use a straight-through cable to connect two ports only when one port is designated with an **X**. Use a crossover cable to connect two ports when both ports are designated with an **X** or when both ports do not have an **X**.

10/100/1000 Ports

The 10/100/1000 Ethernet port on the Catalyst 2940-8TT-S switch uses a standard RJ-45 connector. [Figure B-3](#) shows the pinout.

Figure B-3 RJ-45 Pinouts for 10/100/1000 Port

Pin	Label
1	TP0+
2	TP0-
3	TP1+
4	TP2+
5	TP2-
6	TP1-
7	TP3+
8	TP3-

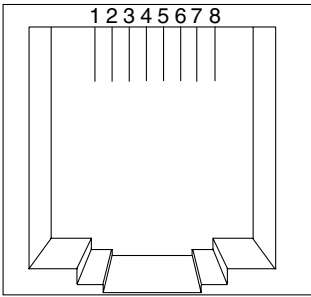

34751

Connecting to 10BASE-T and 100BASE-TX Devices

When connecting the ports to 10BASE-T and 100BASE-TX devices, such as servers, workstations, and routers, you can use a two or four twisted-pair, straight-through cable wired for 10BASE-T and 100BASE-TX. [Figure B-6](#) shows the two twisted-pair, straight-through cable schematics. [Figure B-8](#) shows the four twisted-pair, straight-through cable schematics.

When connecting the ports to 10BASE-T- and 100BASE-TX devices, such as switches or repeaters, you can use a two or four twisted-pair, crossover cable. [Figure B-7](#) shows the two twisted-pair, crossover cable schematics. [Figure B-9](#) shows the four twisted-pair, crossover cable schematics.

You can use Category 3, 4, or 5 cabling when connecting to 10BASE-T devices. You must use Category 5 cabling when connecting to 100BASE-TX devices.

Connecting to 1000BASE-T Devices

When connecting the ports to 1000BASE-T devices, such as servers, workstations, and routers, you must use a four twisted-pair, Category 5, straight-through cable wired for 10BASE-T, 100BASE-TX, and 1000BASE-T. [Figure B-10](#) shows the straight-through cable schematics.

When connecting the ports to other devices, such as switches or repeaters, you must use a four twisted-pair, Category 5, crossover cable. [Figure B-11](#) shows the crossover cable schematics.



Note

Be sure to use a four twisted-pair, Category 5 cable when connecting to a 1000BASE-T device.



Note

Use a straight-through cable to connect two ports only when one port is designated with an **X**. Use a crossover cable to connect two ports when both ports are designated with an **X** or when both ports do not have an **X**.

100BASE-FX Port

The 100BASE-FX port on the Catalyst 2940 8TF-S uses an MT-RJ connector, shown in [Figure B-4](#). This port uses 50/125- or 62.5/125-micron multimode fiber-optic cabling.

You can connect a 100BASE-FX port to an SC port on a target device by using one of the MT-RJ fiber-optic patch cables listed in [Table B-1](#). Use the Cisco part numbers in [Table B-1](#) to order the patch cables that you need.

Figure B-4 MT-RJ Connector

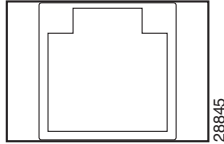

Table B-1 MT-RJ Patch Cables for 100BASE-FX Connections

Type	Cisco Part Number
1-meter, MT-RJ-to-SC multimode cable	CAB-MTRJ-SC-MM-1M
3-meter, MT-RJ-to-SC multimode cable	CAB-MTRJ-SC-MM-3M
5-meter, MT-RJ-to-SC multimode cable	CAB-MTRJ-SC-MM-5M
1-meter, MT-RJ-to-ST multimode cable	CAB-MTRJ-ST-MM-1M
3-meter, MT-RJ-to-ST multimode cable	CAB-MTRJ-ST-MM-3M
5-meter, MT-RJ-to-ST multimode cable	CAB-MTRJ-ST-MM-5M

SFP Module Slot

The Catalyst 2940-8TF-S switch has a slot for SFP modules that provide fiber-optic uplink ports.

[Figure B-5](#) shows an SFP module connector for a fiber-optic connection.

Figure B-5 SFP Module Connector

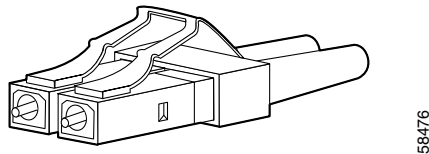

Warning

Invisible laser radiation may be emitted from disconnected fibers or connectors. Do not stare into beams or view directly with optical instruments. Statement 1051



Warning

Invisible laser radiation may be emitted from disconnected fibers or connectors. Do not stare into beams or view directly with optical instruments. Statement 272

Console Port

The console port uses an 8-pin RJ-45 connector. You can connect a switch to a PC through the console port and the supplied RJ-45-to-DB-9 adapter cable. If you want to connect a switch to a terminal, you need to provide an RJ-45-to-DB-25 female DTE adapter. You can order a kit (part number ACS-DSBUASYN=) with that adapter from Cisco. For console-port and adapter-pinout information, see [Table B-2](#) and [Table B-3](#).

Cable and Adapter Specifications

These sections describe the cables and adapters used with Catalyst 2940 switches.

- [Two Twisted-Pair Cable Pinouts, page B-5](#)
- [Four Twisted-Pair Cable Pinouts for 10/100 Ports, page B-6](#)
- [Four Twisted-Pair Cable Pinouts for 1000BASE-T Ports, page B-7](#)
- [Cable and Adapter Pinouts, page B-8](#)

Two Twisted-Pair Cable Pinouts

[Figure B-6](#) and [Figure B-7](#) show the schematics of two twisted-pair cables for 10/100 ports.

Figure B-6 Two Twisted-Pair Straight-Through Cable Schematic for 10/100 Ports

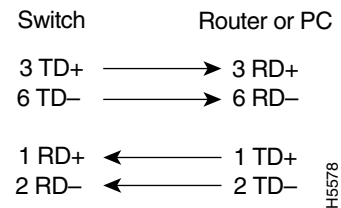
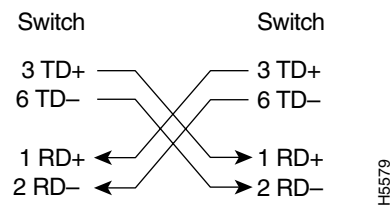

Figure B-7 Two Twisted-Pair Crossover Cable Schematic for 10/100 Ports



Four Twisted-Pair Cable Pinouts for 10/100 Ports

Figure B-8 and Figure B-9 show the schematics of four twisted-pair cables for 10/100 ports.

Figure B-8 Four Twisted-Pair Straight-Through Cable Schematic for 10/100 Ports

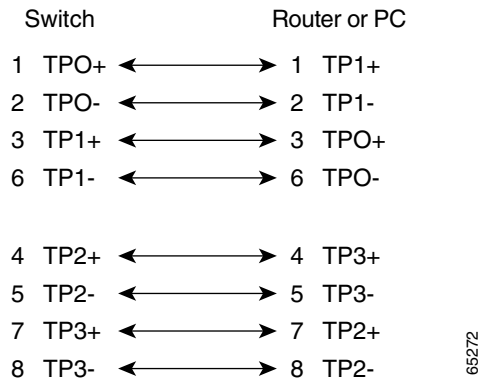
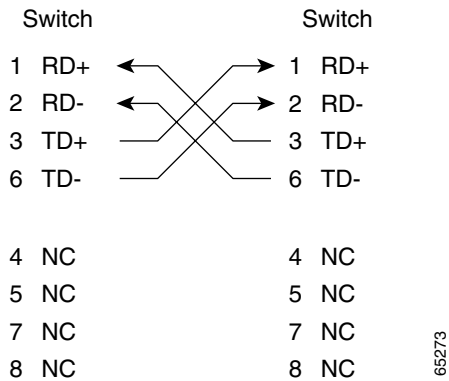

Figure B-9 Four Twisted-Pair Crossover Cable Schematic for 10/100 Ports



Four Twisted-Pair Cable Pinouts for 1000BASE-T Ports

Figure B-10 and Figure B-11 show the schematics of four twisted-pair cables for the 10/100/1000 port.

Figure B-10 Four Twisted-Pair Straight-Through Cable Schematic for 10/100/1000 and 1000BASE-T GBIC Module Ports

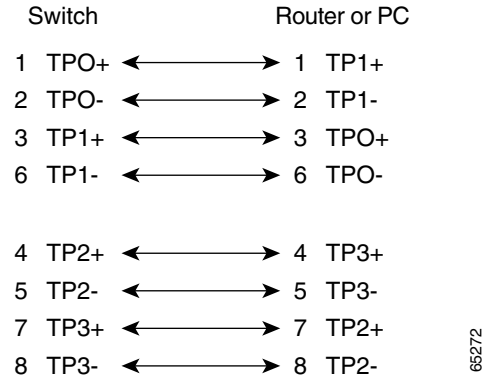
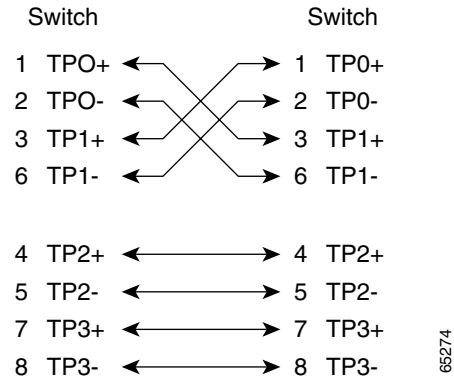

Figure B-11 Four Twisted-Pair Crossover Cable Schematics for 10/100/1000 and 1000BASE-T GBIC Module Ports



Cable and Adapter Pinouts

This section describes the cable and adapter pinouts and also describes how to identify a rollover cable.

Connecting to a PC

Use the supplied RJ-45-to-DB-9 adapter cable to connect the console port to a PC running terminal-emulation software. [Table B-2](#) lists the pinouts for the console port and the RJ-45-to-DB-9 adapter cable.

Table B-2 Console Port Signaling and RJ-45-to-DB-9 Adapter Cabling

Console Port (DTE)	RJ-45-to-DB-9 Adapter Cable		Console Device
Signal	RJ-45 Pin	DB-9 Pin	Signal
RTS	1	8	CTS
Not connected	2	6	DSR
TxD	3	2	RxD
GND	4	5	GND
GND	5	5	GND
RxD	6	3	TxD
Not connected	7	4	DTR
CTS	8	7	RTS

Connecting to a Terminal

Use the supplied RJ-45-to-DB-9 adapter cable and an RJ-45-to-DB-25 female DTE adapter to connect the console port to a terminal. [Table B-3](#) lists the pinouts for the console port, the adapter cable, and the RJ-45-to-DB-25 adapter.



Note

The RJ-45-to-DB-25 female DTE adapter is not supplied with the switch. You can order a kit (part number ACS-DSBUASYN=) with that adapter from Cisco.

Table B-3 Console Port Signaling and Cabling Using a DB-25 Adapter

Console Port (DTE)	RJ-45-to-DB-9 Adapter Cable		RJ-45-to-DB-25 Terminal Adapter	Console Device
	RJ-45 Pin	DB-9 Pin	DB-25 Pin	Signal
RTS	1	8	5	CTS
Not connected	2	6	6	DSR
TxD	3	2	3	RxD
GND	4	5	7	GND
GND	5	5	7	GND
RxD	6	3	2	TxD
Not connected	7	4	20	DTR
CTS	8	7	4	RTS

Identifying a Rollover Cable

You can identify a rollover cable, also known as a “crossover” cable, by comparing the two modular cable ends. Hold the cable ends side-by-side, with the tab at the back, right plug, as shown in [Figure B-12](#).

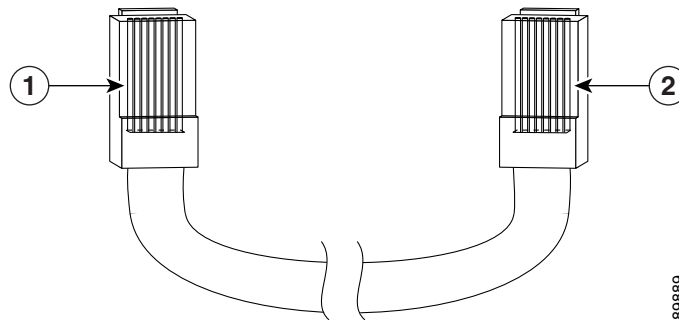
Figure B-12 Identifying a Rollover Cable

1	Pin 1
2	Pin 9

On a rollover cable, the wire connected to the pin on the outside of the left plug should be the same color as the wire connected to the pin on the outside of the right plug.

