

# Configuring Dynamic VLAN Membership

---

This chapter describes how to configure dynamic port VLAN membership by using the VLAN Membership Policy Server (VMPS).

---

**Note** For complete syntax and usage information of the commands used in this chapter, refer to the *Cisco IOS Desktop Switching Command Reference* publication.

---

These sections describe how to configure dynamic VLANs:

- “How the VMPS Works” section on page 4-1
- “Configuring Dynamic VLAN Membership” section on page 4-5
- “VMPS Database Configuration File Example” section on page 4-11

## How the VMPS Works

With the VMPS, you can assign switch ports to VLANs dynamically, based on the source Media Access Control (MAC) address of the device connected to the port. When you move a host from a port on one switch in the network to a port on another switch in the network, that switch dynamically assigns the new port to the proper VLAN for that host.

Switches running IOS Release 12.0(5)XP can be member or command switches in a cluster of switches managed as a single entity. The communication between VMPS and a member switch is managed by the command switch. In this description, the VMPS client is always the command switch.

A switch running IOS Release 12.0(5)XP acts as a client to the VMPS and communicates with it via the VLAN Query Protocol (VQP). When the VMPS receives a VQP request from a client switch, it searches its database for a MAC address-to-VLAN mapping. The server response is based on this mapping and whether or not the server is in secure mode. Secure mode determines whether the server shuts down the port when a VLAN is not allowed on it or just denies the port access to the VLAN.

In response to a request, the VMPS takes one of the following actions:

- If the assigned VLAN is restricted to a group of ports, the VMPS verifies the requesting port against this group and responds as follows:
  - If the VLAN is allowed on the port, the VMPS sends the VLAN name to the client in response.
  - If the VLAN is not allowed on the port, and the VMPS is not in secure mode, the VMPS sends an *access-denied* response.
  - If the VLAN is not allowed on the port, and the VMPS is in secure mode, the VMPS sends a *port-shutdown* response.
- If the VLAN in the database does not match the current VLAN on the port and there are active hosts on the port, the VMPS sends an *access-denied* or a *port-shutdown* response, depending on the secure mode of the VMPS.

If the switch receives an *access-denied* response from the VMPS, it continues to block traffic from the MAC address to or from the port. The switch continues to monitor the packets directed to the port and sends a query to the VMPS when it identifies a new address. If the switch receives a *port-shutdown* response from the VMPS, it disables the port. The port must be manually reenabled by using the CLI, Cisco Visual Switch Manager (CVSM), or SNMP.

You can also use an explicit entry in the configuration table to deny access to specific MAC addresses for security reasons. If you enter the **--NONE--** keyword for the VLAN name, the VMPS sends an *access-denied* or *port-shutdown* response.

## Entering Port Names in the VMPS

A VMPS database configuration file must use the 2900 XL and 3500 XL convention for naming ports. For example, Fa0/5 is fixed-port number 5.

If the switch is a cluster member, the command switch adds the name of the switch before the Fa. For example, es3%Fa02 refers to fixed 10/100 port 2 on member switch 3. These naming conventions must be used in the VMPS database configuration file when it is configured to support a cluster.

You can configure a fallback VLAN name. If you connect a device with a MAC address that is not in the database, the VMPS sends the fallback VLAN name to the client. If you do not configure a fallback VLAN and the MAC address does not exist in the database, the VMPS sends an *access-denied* response. If the VMPS is in secure mode, it sends a *port-shutdown* response.

---

**Note** A switch running IOS Release 12.0(5)XP cannot act as the VMPS. Use a Catalyst 5000 series switch as the VMPS.

---

## Dynamic Port VLAN Membership

A dynamic (nontrunking) port can belong to only one VLAN. When the link comes up, the switch does not forward traffic to or from this port until the port is assigned to a VLAN. The source MAC address from the first packet of a new host on the dynamic port is sent to the VMPS which attempts to match the MAC address to a VLAN in the VMPS database. If there is a match, the VMPS sends the VLAN number for that port. If there is no match, the VMPS either denies the request or shuts down the port (depending on the VMPS secure mode setting). See the “How the VMPS Works” section on page 4-1 for a complete description of possible VMPS responses.



**Caution** Dynamic port VLAN membership is for end stations. Connecting dynamic ports to other switches can cause a loss of connectivity.

Multiple hosts (MAC addresses) can be active on a dynamic port if they are all in the same VLAN. If the link goes down on a dynamic port, the port returns to an isolated state and does not belong to a VLAN. Any hosts that come online through the port are checked again with the VMPS before the port is assigned to a VLAN.

---

**Note** The VMPS shuts down a dynamic port if more than 20 hosts are active on the port.

---

## VMPS Configuration Guidelines

The following guidelines and restrictions apply to dynamic port VLAN membership:

- You must configure the VMPS before you configure ports as dynamic.
- The communication between a cluster of switches and VMPS is managed by the command switch and includes port-naming conventions that are different from standard port names. See “Entering Port Names in the VMPS” section on page 4-3 for the cluster-based port-naming conventions.
- When you configure a port as dynamic, the spanning-tree Port Fast feature is automatically enabled for that port. The Port Fast mode accelerates the process of bringing the port into the forwarding state. You can disable Port Fast mode on a dynamic port.
- Secure ports cannot be dynamic ports. You must disable port security on the port before it becomes dynamic.
- Trunk ports cannot be dynamic ports, but it is possible to enter the **switchport access VLAN dynamic** command for a trunk port. In this case, the switch retains the setting and applies it if the port is later configured as an access port.  
You must turn off trunking on the port before the dynamic access setting takes effect.
- Dynamic ports cannot be network ports or monitor ports.

---

**Note** The VTP management domain of the VMPS client and the VMPS server must be the same.

---

## Default VMPS Configuration

Table 4-1 shows the default VMPS and dynamic port configuration on client switches.

**Table 4-1 Default VMPS Client and Dynamic Port Configuration**

Feature	Default Configuration
VMPS domain server	None
VMPS reconfirm interval	60 minutes
VMPS server retry count	3
Dynamic ports	None configured

## Configuring Dynamic VLAN Membership

These sections describe how to configure a switch as a VMPS client and configure its ports for dynamic VLAN membership.

### Entering the IP Address of the VMPS

To configure the switch as a client, you must enter the IP address of the Catalyst 5000 switch or the other device acting as the VMPS. If the VMPS is being defined for a cluster of switches, perform this task from privileged EXEC mode on the command switch:

Task	Command
<b>Step 1</b> Enter global configuration mode.	<b>configure terminal</b>
<b>Step 2</b> Enter the IP address of the switch acting as the primary VMPS server.	<b>vmips server <i>ipaddress</i> primary</b>
<b>Step 3</b> Enter the IP address for the switch acting as a secondary VMPS server.	<b>vmips server <i>ipaddress</i></b>
<b>Step 4</b> Return to privileged EXEC mode.	<b>end</b>
<b>Step 5</b> Verify the VMPS server entry.	<b>show vmips</b>

This example shows how to enter the primary and backup VMPS devices:

```
Switch# configure terminal
Enter configuration commands, one per line. End with CNTL/Z.
Switch(config)# vmmps server 172.20.128.179 primary
Switch(config)# vmmps server 172.20.128.178
Switch(config)# end

Switch# show vmmps
VQP Client Status:
-----
VMPS VQP Version: 1
Reconfirm Interval: 60 min
Server Retry Count: 3
→ VMPS domain server: 172.20.128.179 (primary, current)
                        172.20.128.178

Reconfirmation status
-----
VMPS Action:          No Dynamic Port
```

## Configuring Dynamic Ports on VMPS Clients

If you are configuring a port on a member switch as a dynamic port, first log in to the member switch by using the privileged EXEC **rcommand** command. See the *Cisco IOS Desktop Switching Command Reference* for more information on how to use this command.

To configure dynamic ports on the VMPS client switches, perform this task from privileged EXEC mode:

Task	Command
<b>Step 1</b> Enter global configuration mode.	<b>configure terminal</b>
<b>Step 2</b> Enter interface configuration mode and the port to be configured.	<b>interface interface</b>
<b>Step 3</b> Set the port to access mode.	<b>switchport mode access</b>
<b>Step 4</b> Configure the port as eligible for dynamic VLAN access.	<b>switchport access vlan dynamic</b>
<b>Step 5</b> Return to privileged EXEC mode.	<b>end</b>
<b>Step 6</b> Verify the entry.	<b>show interface interface switchport</b>

This example shows how to configure a port as a dynamic access port and then verify the entry:

```
Switch# configure terminal
Enter configuration commands, one per line. End with CNTL/Z.
Switch(config)# interface fa0/1
Switch(config-if)# switchport mode access
Switch(config-if)# switchport access vlan dynamic
Switch(config-if)# end

Switch# show interface fa0/1 switchport
Name: Fa0/1
Switchport: Enabled
Administrative mode: dynamic access
→ Operational Mode: dynamic access
Administrative Trunking Encapsulation: isl
Operational Trunking Encapsulation: isl
Negotiation of Trunking: Disabled
Access Mode VLAN: 0 ((Inactive))
Trunking Native Mode VLAN: 1 (default)
Trunking VLANs Enabled: NONE
Pruning VLANs Enabled: NONE
```

## Administering and Monitoring the VMPS

You can display information about the VMPS by using the privileged EXEC **show vmps** command. The switch displays the following information about the VMPS:

VMPS VQP Version	The version of VQP used to communicate with the VMPS. The switch queries the VMPS using version 1 of VQP.
Reconfirm Interval	The number of minutes the switch waits before reconfirming the VLAN-to-MAC-address assignments.
Server Retry Count	The number of times VQP resends a query to the VMPS. If no response is received after this many tries, the switch starts to query the secondary VMPS.

## Configuring Dynamic VLAN Membership

---

VMPS domain server	The IP address of the configured VLAN membership policy servers. The switch currently sends queries to the one marked <i>current</i> . The one marked <i>primary</i> is the primary server.
VMPS Action	The result of the most-recent reconfirmation attempt. This can happen automatically when the reconfirmation interval expired, or you can force it by entering the privileged EXEC <b>vmpls reconfirm</b> command or its CVSM or SNMP equivalent.

The following example shows how to display VMPS information. You can enter this information on a command or member switch:

```
Switch# show vmpls
VQP Client Status:
-----
VMPS VQP Version: 1
Reconfirm Interval: 60 min
Server Retry Count: 3
VMPS domain server:

Reconfirmation status
-----
VMPS Action:          other
```

The following example shows how to display VMPS statistics:

```
Switch# show vmpls statistics
VMPS Client Statistics
-----
VQP Queries:          0
VQP Responses:        0
VMPS Changes:         0
VQP Shutdowns:       0
VQP Denied:           0
VQP Wrong Domain:    0
VQP Wrong Version:   0
VQP Insufficient Resource: 0
```

---

**Note** The *Cisco IOS Desktop Switching Command Reference* describes the VMPS statistics.

---

## Configuring the Reconfirmation Interval

VMPS clients periodically reconfirm the VLAN membership information received from the VMPS. You can set the interval after which the reconfirmation occurs.

If you are configuring a member switch in a cluster, this parameter must be equal to or greater than the reconfirmation setting on the command switch. In addition, you must first log in to the member switch by using the privileged EXEC **rcommand** command. See the *Cisco IOS Desktop Switching Command Reference* for more information on how to use this command.

Perform this task from privileged EXEC mode:

Task	Command
<b>Step 1</b> Enter global configuration mode.	<b>configure terminal</b>
<b>Step 2</b> Enter the number of minutes between reconfirmations of the dynamic VLAN membership.	<b>vmpls reconfirm <i>minutes</i></b>
<b>Step 3</b> Return to privileged EXEC mode.	<b>end</b>
<b>Step 4</b> Verify the dynamic VLAN reconfirmation status.	<b>show vmpls</b>

This example shows how to change the reconfirmation interval to 60 minutes and verify the change by displaying the VMPS information:

```

Switch# configure terminal
Enter configuration commands, one per line.  End with CNTL/Z.
Switch(config)# vmpls reconfirm 60
Switch(config)# end

Switch# show vmpls
VQP Client Status:
-----
VMPS VQP Version: 1
→ Reconfirm Interval: 60 min
Server Retry Count: 10
VMPS domain server: 172.20.130.50 (primary, current)

Reconfirmation status
-----
VMPS Action:          No Host
  
```

### Reconfirming VLAN Memberships

To confirm the dynamic port VLAN membership assignments that the switch has received from the VMPS, perform this task from privileged EXEC mode:

Task	Command
<b>Step 1</b> Reconfirm dynamic port VLAN membership.	<b>vmps reconfirm</b>
<b>Step 2</b> Verify the dynamic VLAN reconfirmation status.	<b>show vmps</b>

This example shows how to reconfirm dynamic port VLAN membership assignments from privileged EXEC mode:

```
Switch# vmps reconfirm
Switch# show vmps
VQP Client Status:
-----
VMPS VQP Version: 1
Reconfirm Interval: 60 min
Server Retry Count: 10
VMPS domain server: 172.20.130.50 (primary, current)

Reconfirmation status
-----
VMPS Action: Success
```

### Troubleshooting Dynamic Port VLAN Membership

The VMPS shuts down a dynamic port under these conditions:

- The VMPS is in secure mode, and it will not allow the host to connect to the port. The VMPS shuts down the port to prevent the host from connecting to the network.
- More than 20 active hosts reside on a dynamic port.

To reenabale a shut-down dynamic port, enter the interface configuration mode **no shutdown** command.

## VMPS Database Configuration File Example

This example shows a sample VMPS database configuration file as it appears on a Catalyst 5000 series switch. A VMPS database configuration file is an ASCII text file that is stored on a TFTP server accessible to the switch that functions as the VMPS server.

```
!vmmps domain <domain-name>
! The VMPS domain must be defined.
!vmmps mode { open | secure }
! The default mode is open.
!vmmps fallback <vlan-name>
!vmmps no-domain-req { allow | deny }
!
! The default value is allow.
vmmps domain WBU
vmmps mode open
vmmps fallback default
vmmps no-domain-req deny
!
!
!MAC Addresses
!
vmmps-mac-addr
!
! address <addr> vlan-name <vlan_name>
!
address 0012.2233.4455 vlan-name hardware
address 0000.6509.a080 vlan-name hardware
address aabb.ccdd.eeff vlan-name Green
address 1223.5678.9abc vlan-name ExecStaff
address fedc.ba98.7654 vlan-name --NONE--
address fedc.ba23.1245 vlan-name Purple
!
!Port Groups
!
!vmmps-port-group <group-name>
! device <device-id> { port <port-name> | all-ports }
!
vmmps-port-group WiringCloset1
  device 198.92.30.32 port Fa1/3
  device 172.20.26.141 port Fa1/4
vmmps-port-group "Executive Row"
  device 198.4.254.222 port es5%Fa0/1
  device 198.4.254.222 port es5%Fa0/2
```

```
device 198.4.254.223 all-ports
!
!VLAN groups
!
!vmmps-vlan-group <group-name>
! vlan-name <vlan-name>
!
vmmps-vlan-group Engineering
vlan-name hardware
vlan-name software
!
!VLAN port Policies
!
!vmmps-port-policies {vlan-name <vlan_name> | vlan-group <group-name> }
! { port-group <group-name> | device <device-id> port <port-name> }
!
vmmps-port-policies vlan-group Engineering
port-group WiringCloset1
vmmps-port-policies vlan-name Green
device 198.92.30.32 port Fa0/9
vmmps-port-policies vlan-name Purple
device 198.4.254.22 port Fa0/10
port-group "Executive Row"
```

## Dynamic Port VLAN Membership Configuration Example

Figure 4-1 shows a network with a VMPS server switch and VMPS client switches with dynamic ports. In this example, these assumptions apply:

- The VMPS server and the VMPS client are separate switches.
- The Catalyst 5000 series Switch 1 is the primary VMPS server.
- The Catalyst 5000 series Switch 3 and Switch 10 are secondary VMPS servers.
- End stations are connected to these clients:
  - Catalyst 2900 series XL Switch 2
  - Catalyst 2900 series XL Switch 9
- The database configuration file is called Bldg-G.db and is stored on the TFTP server with the IP address 172.20.22.7.

Figure 4-1 Dynamic Port VLAN Membership Configuration

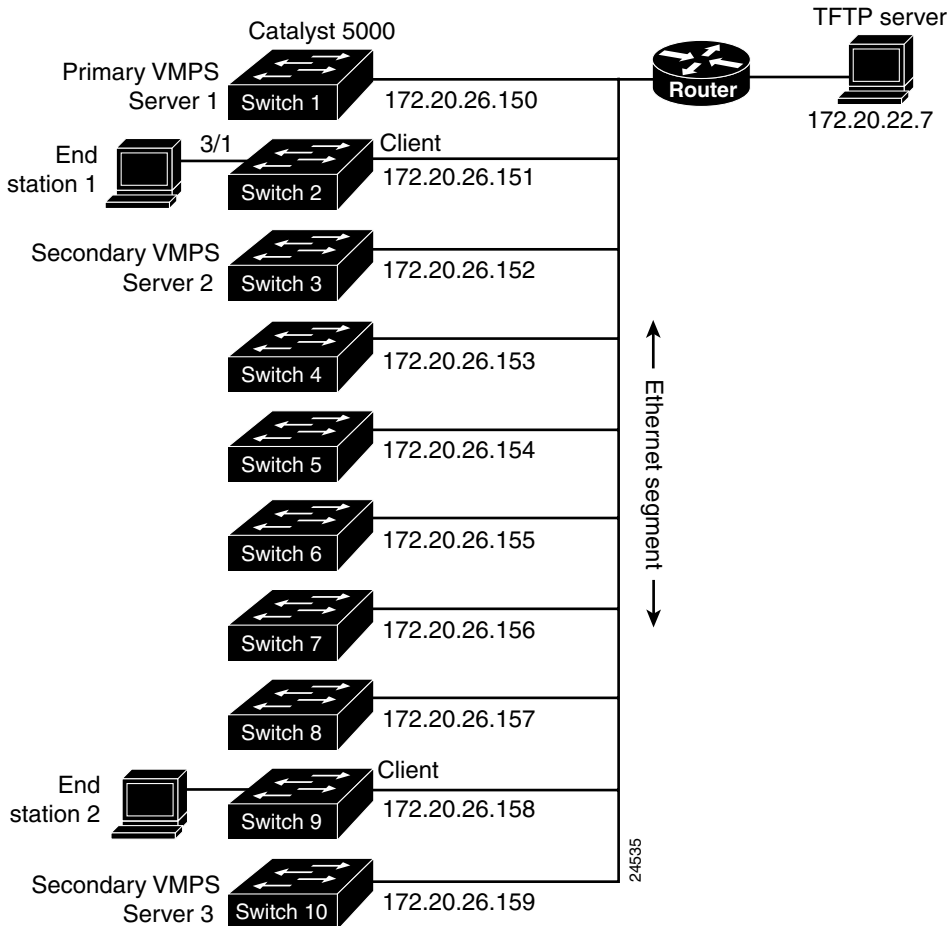

## Configuring Dynamic VLAN Membership

---

In this procedure, the Catalyst 5000 switches are the VMPS servers. Use this procedure to configure the 3500 and 2900 XL clients in the network:

**Step 1** Configure the VMPS server addresses on Switch 2, the client switch.

(a) Starting from privileged EXEC mode, enter global configuration mode:

```
switch# configuration terminal
```

(a) Enter the primary VMPS server IP address:

```
switch(config)# vmps server 172.20.26.150 primary
```

(b) Enter the secondary VMPS server IP addresses:

```
switch(config)# vmps server 172.20.26.152
```

(c) To verify your entry of the VMPS IP addresses, return to privileged EXEC mode:

```
switch#(config) exit
```

(d) Display VMPS information configured for the switch:

```
switch# show vmps  
VQP Client Status:  
-----  
VMPS VQP Version: 1  
Reconfirm Interval: 60 min  
Server Retry Count: 3  
VMPS domain server: 172.20.26.152  
                    172.20.26.150 (primary, current)
```

**Step 2** Configure port Fa0/1 on Switch 2 as a dynamic port.

(a) Return to global configuration mode:

```
switch# configure terminal
```

(b) Enter interface configuration mode:

```
switch(config)# interface fa0/1
```

(c) Configure the VLAN membership mode for static-access ports:

```
switch(config-if)# switchport mode access
```

(d) Assign the port dynamic VLAN membership:

```
switch(config-if)# switchport access vlan dynamic
```

(e) Return to privileged EXEC mode:

```
switch(config-if)# exit  
switch#
```

**Step 3** Connect End Station 2 on port Fa0/1. When End Station 2 sends a packet, Switch 2 sends a query to the primary VMPS server, Switch 1. Switch 1 responds with the VLAN ID for port Fa0/1. Because Spanning-Tree Protocol Port Fast mode is enabled by default on dynamic ports, port Fa0/1 connects immediately and begins forwarding.

**Step 4** Set the VMPS reconfirmation period to 60 minutes. The reconfirmation period is the number of minutes the switch waits before reconfirming the VLAN to MAC address assignments.

```
switch# config terminal  
switch(config)# vmmps reconfirm 60
```

**Step 5** Confirm the entry from privileged EXEC mode:

```
switch# show vmmps  
VQP Client Status:  
-----  
VMPS VQP Version: 1  
Reconfirm Interval: 60 min  
Server Retry Count: 3  
VMPS domain server:  
  
Reconfirmation status  
-----  
VMPS Action: No Dynamic Port
```

**Step 6** Repeat Steps 1 and 2 to configure the VMPS server addresses and assign dynamic ports on each VMPS client switch.

