



Configuring VLANs

This chapter provides information about configuring virtual LANs (VLANs). It includes command-line interface (CLI) procedures for using commands that have been specifically created or changed for the Catalyst 2900 XL or Catalyst 3500 XL switches. For complete syntax and usage information for the commands used in this chapter, refer to the *Catalyst 2900 Series XL and Catalyst 3500 Series XL Command Reference*.



Note

Certain port features can conflict with one another. Review the [“Avoiding Configuration Conflicts”](#) section on [page 9-2](#) before you change the port settings.

This chapter does not repeat the concepts and CLI procedures provided in the standard Cisco IOS Release 12.0 documentation. For switch features that use standard Cisco IOS Release 12.0 commands, refer to the Cisco IOS Release 12.0 documentation on Cisco.com for additional information and CLI procedures.

For information about configuring these settings from Cluster Management Suite (CMS), refer to the online help.



Note

Some features can be implemented only by using the CLI.

Overview

A virtual LAN (VLAN) is a switched network that is logically segmented by function, project team, or application, without regard to the physical locations of the users. Any switch port can belong to a VLAN, and unicast, broadcast, and multicast packets are forwarded and flooded only to stations in the VLAN. Each VLAN is considered a logical network, and packets destined for stations that do not belong to the VLAN must be forwarded through a router or bridge as shown in [Figure 8-1](#). VLANs are identified with a number of 1 to 1001.

Because a VLAN is considered a separate logical network, it contains its own bridge Management Information Base (MIB) information and can support its own implementation of the Spanning Tree Protocol (STP). For information about managing VLAN STP instances, see the [“Supported STP Instances”](#) section on [page 6-24](#).

Figure 8-1 VLANs as Logically Defined Networks

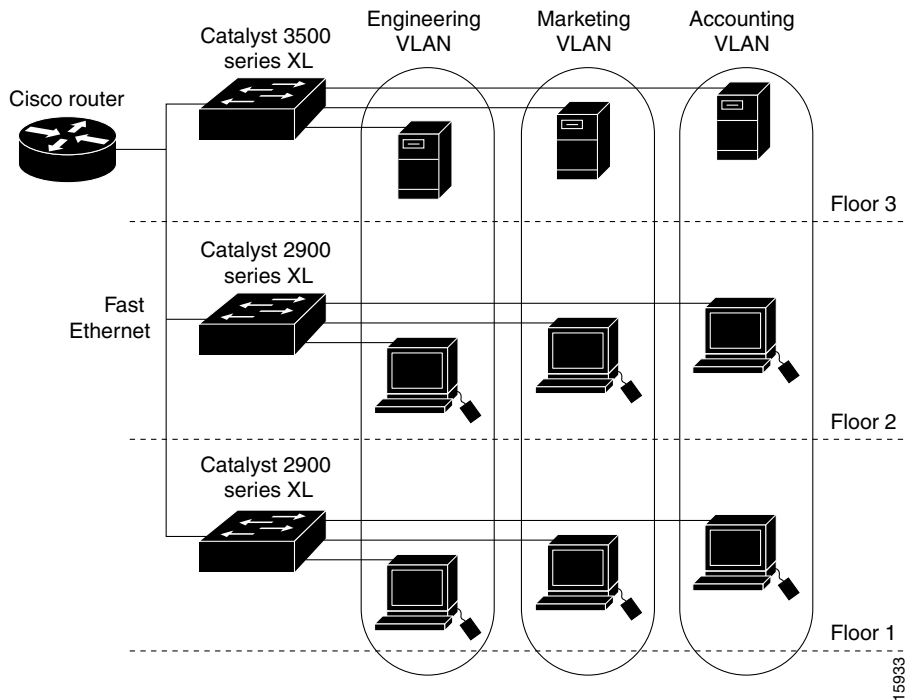

15933

Table 8-1 lists the number of supported VLANs on the switches.

Table 8-1 Maximum Number of Supported VLANs

Switch	Number of Supported VLANs	Trunking Supported?
Catalyst 2912 XL, Catalyst 2924 XL, and Catalyst 2924C XL switches	64	Yes
Catalyst 2900 LRE XL switches	250	Yes
Catalyst 2912M and Catalyst 2924M modular switches	250	Yes
Catalyst 3500 XL switches	250	Yes

The switches in Table 8-1 support both Inter-Switch Link (ISL) and IEEE 802.1Q trunking methods for transmitting VLAN traffic over 100BASE-T and Gigabit Ethernet ports.

The GigaStack GBIC also supports both trunking methods. When you are configuring a cascaded stack of Catalyst 3500 XL switches using the GigaStack GBIC and want to include more than one VLAN in the stack, be sure to configure all of the GigaStack GBIC interfaces as trunk ports by using the **switchport mode trunk** interface configuration command and to use the same encapsulation method by using the **switchport encapsulation {isl | dot1q}** interface configuration command. For more information on these commands, refer to the *Catalyst 2900 Series XL and Catalyst 3500 Series XL Command Reference*.

Trunking is not supported on all switches and modules. For the list of products that support trunking, refer to the release notes.

Management VLANs

Communication with the switch management interfaces is through the switch IP address. The IP address is associated with the management VLAN, which by default is VLAN 1.

The management VLAN has the following characteristics:

- It is created from CMS or through the CLI on static-access, multi-VLAN, and dynamic-access and trunk ports. You cannot create or remove the management VLAN through Simple Network Management Protocol (SNMP).
- Only one management VLAN can be administratively active at a time.
- With the exception of VLAN 1, the management VLAN can be deleted.
- When created, the management VLAN is administratively down.

Before changing the management VLAN on your switch network, make sure you follow these guidelines:

- The new management VLAN should not have an Hot Standby Router Protocol (HSRP) standby group configured on it.
- You must be able to move your network management station to a switch port assigned to the same VLAN as the new management VLAN.
- Connectivity through the network must exist from the network management station to all switches involved in the management VLAN change.
- Switches running a version of IOS software that is earlier than Cisco IOS 12.0(5)XP cannot change the management VLAN.
- Switches running Cisco IOS 12.0(5)XP should be upgraded to the current software release as described in the release notes.

If you are using SNMP or CMS to manage the switch, ensure that the port through which you are connected to a switch is in the management VLAN.

For information about the role management VLANs play in switch clusters, see the [“Management VLAN” section on page 5-11](#).

Changing the Management VLAN for a New Switch

If you add a new switch to an existing cluster and the cluster is using a management VLAN other than the default VLAN 1, the command switch automatically senses that the new switch has a different management VLAN and has not been configured. The command switch issues commands to change the management VLAN on the new switch to match the one in use by the cluster. This automatic change of the VLAN only occurs for new, out-of-box switches that do not have a config.text file and for which there have been no changes to the running configuration.

Before a new switch can be added to a cluster, it must be connected to a port that belongs to the cluster management VLAN. If the cluster is configured with a management VLAN other than the default, the command switch changes the management VLAN for new switches when they are connected to the cluster. In this way, the new switch can exchange CDP messages with the command switch and be proposed as a cluster candidate.

**Note**

For the command switch to change the management VLAN on a new switch, there must have been no changes to the new switch configuration, and there must be no config.text file.

Because the switch is new and unconfigured, its management VLAN is changed to the cluster management VLAN when it is first added to the cluster. All ports that have an active link at the time of this change become members of the new management VLAN.

For information about the role management VLANs play in switch clusters, see the [“Management VLAN” section on page 5-11](#).

Changing the Management VLAN Through a Telnet Connection

Before you start, review the [“Management VLANs” section on page 8-4](#). Beginning in privileged EXEC mode on the command switch, follow these steps to configure the management VLAN interface through a Telnet connection:

	Command	Purpose
Step 1	configure terminal	Enter global configuration mode.
Step 2	cluster management-vlan <i>vlanid</i>	Change the management VLAN for the cluster. This ends your Telnet session. Move the port through which you are connected to the switch to a port in the new management VLAN.
Step 3	show running-config	Verify the change.

Assigning VLAN Port Membership Modes

You configure a port to belong to a VLAN by assigning a membership mode that determines the kind of traffic the port carries and the number of VLANs it can belong to. [Table 8-2](#) lists the membership modes and characteristics.

Table 8-2 Port Membership Modes

Membership Mode	VLAN Membership Characteristics
Static-access	A static-access port can belong to one VLAN and is manually assigned. By default, all ports are static-access ports assigned to VLAN 1.
Multi-VLAN	A multi-VLAN port can belong to up to 250 VLANs (some models only support 64 VLANs) and is manually assigned. You cannot configure a multi-VLAN port when a trunk is configured on the switch. VLAN traffic on the multi-VLAN port is not encapsulated.
Trunk (ISL, ATM, or IEEE 802.1Q)	<p>A trunk is a member of all VLANs in the VLAN database by default, but membership can be limited by configuring the allowed-VLAN list. You can also modify the pruning-eligible list to block flooded traffic to VLANs on trunk ports that are included in the list.</p> <p>VLAN Trunk Protocol (VTP) maintains VLAN configuration consistency by managing the addition, deletion, and renaming of VLANs on a network-wide basis. VTP exchanges VLAN configuration messages with other switches over trunk links.</p> <p>Note By using the Asynchronous Transfer Mode (ATM) module CLI, you can map the LAN emulation (LANE) client to a VLAN or bind one or more permanent virtual connections (PVCs) to a VLAN. The VLAN ID is then displayed in the Assigned VLANs column of the VLAN Membership window. An ATM port can only be a trunk port. For more information, refer to the <i>Catalyst 2900 Series XL ATM Modules Installation and Configuration Guide</i>.</p>
Dynamic access	A dynamic-access port can belong to one VLAN and is dynamically assigned by a VLAN Membership Policy Server (VMPS). The VMPS can be a Catalyst 5000 series switch but never a Catalyst 2900 XL or Catalyst 3500 XL switch.

When a port belongs to a VLAN, the switch learns and manages the addresses associated with the port on a per-VLAN basis. For more information, see the [“Managing the MAC Address Tables”](#) section on page 6-56.

VLAN Membership Combinations

You can configure your switch ports in various VLAN membership combinations as listed in [Table 8-3](#).

Table 8-3 VLAN Combinations

Port Mode	VTP Required?	Configuration Procedure	Comments
Static-access ports	No	“Assigning Static-Access Ports to a VLAN” section on page 8-10	If you do not want to use VTP to globally propagate the VLAN configuration information, you can assign a static-access port to a VLAN and set the VTP mode to <i>transparent</i> to disable VTP.
Static-access and multi-VLAN ports	No	“Overlapping VLANs and Multi-VLAN Ports” section on page 8-11 “Assigning Static-Access Ports to a VLAN” section on page 8-10	You must connect the multi-VLAN port to a router or server. The switch automatically transitions to VTP transparent mode (VTP is disabled). No VTP configuration is required. Some restrictions apply to multi-VLAN ports. For more information, see the “Avoiding Configuration Conflicts” section on page 9-2.

Table 8-3 VLAN Combinations (continued)

Port Mode	VTP Required?	Configuration Procedure	Comments
Static-access and trunk ports	Recommended	<p>“Configuring VTP Server Mode” section on page 8-21</p> <p>Add, modify, or remove VLANs in the database as described in the “Configuring VLANs in the VTP Database” section on page 8-32</p> <p>“Assigning Static-Access Ports to a VLAN” section on page 8-35</p> <p>“Configuring a Trunk Port” section on page 8-38</p>	<p>You can configure at least one trunk port on the switch and make sure that this trunk port is connected to the trunk port of a second switch.</p> <p>Some restrictions apply to trunk ports. For more information, see the “Trunks Interacting with Other Features” section on page 8-37.</p> <p>You can change the VTP version on the switch and enable VTP pruning.</p> <p>You can define the allowed-VLAN list, change the pruning-eligible list, and configure the native VLAN for untagged traffic on the trunk port.</p>
Dynamic-access and trunk ports	Yes	<p>“Configuring Dynamic VLAN Membership” section on page 8-57</p> <p>“Configuring Dynamic Ports on VMPS Clients” section on page 8-58</p> <p>“Configuring a Trunk Port” section on page 8-38 so that the VMPS client can receive VTP information from the VMPS</p>	<p>You must connect the dynamic-access port to an end station and not to another switch.</p> <p>Configure the VMPS and the client with the same VTP domain name.</p> <p>You can change the reconfirmation interval and the retry count on the VMPS client switch.</p> <p>You can define the allowed-VLAN list, change the pruning-eligible list, and configure the native VLAN for untagged traffic on the trunk port.</p>

Assigning Static-Access Ports to a VLAN

By default, all ports are static-access ports assigned to the management VLAN, VLAN 1.

You can assign a static-access port to a VLAN without having VTP globally propagate VLAN configuration information (VTP is disabled). Configuring the switch for VTP transparent mode disables VTP.

Beginning in privileged EXEC mode, follow these steps to assign ports for multi-VLAN membership:

	Command	Purpose
Step 1	configure terminal	Enter global configuration mode.
Step 2	interface <i>interface</i>	Enter interface configuration mode, and enter the port to be added to the VLAN.
Step 3	switchport mode multi	Enter the VLAN membership mode for multi-VLAN ports.
Step 4	switchport multi vlan <i>vlan-list</i>	Assign the port to more than one VLAN. Separate nonconsecutive VLAN IDs with a comma; use a hyphen to designate a range of IDs. Configuring a switch port for multi-VLAN mode causes VTP to transition to transparent mode, which disables VTP.
Step 5	end	Return to privileged EXEC mode.
Step 6	show interface <i>interface-id</i> switchport	Verify your entries.

Overlapping VLANs and Multi-VLAN Ports

A multi-VLAN port connected to a router can link two or more VLANs. Intra-VLAN traffic stays within the boundaries of the respective VLANs as shown in [Figure 8-2](#). Connectivity between VLANs is through the router connected to the multi-VLAN port.

A multi-VLAN port performs normal switching functions in all its assigned VLANs. For example, when a multi-VLAN port receives an unknown Media Access Control (MAC) address, all the VLANs to which the port belongs learn the address. Multi-VLAN ports also respond to the STP messages generated by the different instances of STP in each VLAN.

For the restrictions that apply to multi-VLAN ports, see the [“Avoiding Configuration Conflicts”](#) section on page 9-2.

Figure 8-2 Two VLANs Sharing a Port Connected to a Router

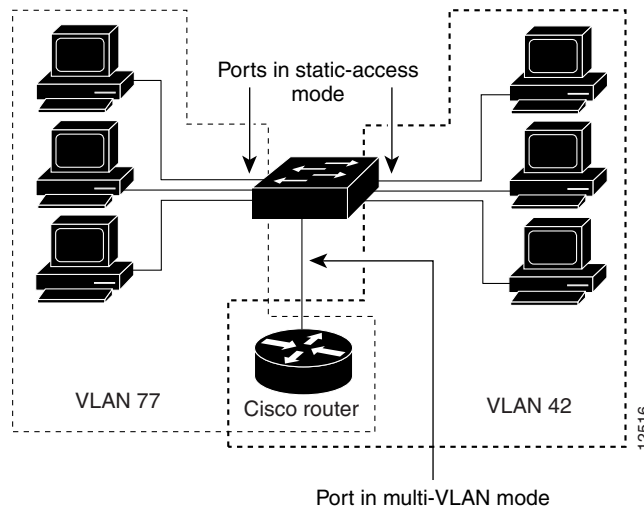

Caution

To avoid unpredictable STP behavior and a loss of connectivity, do not connect multi-VLAN ports to hubs or switches. Connect multi-VLAN ports to routers or servers.

Beginning in privileged EXEC mode, follow these steps to assign ports for multi-VLAN membership:

	Command	Purpose
Step 1	configure terminal	Enter global configuration mode.
Step 2	interface <i>interface</i>	Enter interface configuration mode, and enter the port to be added to the VLAN.
Step 3	switchport mode multi	Enter the VLAN membership mode for multi-VLAN ports.
Step 4	switchport multi vlan <i>vlan-list</i>	Assign the port to more than one VLAN. Separate nonconsecutive VLAN IDs with a comma; use a hyphen to designate a range of IDs. Configuring a switch port for multi-VLAN mode causes VTP to transition to transparent mode, which disables VTP.
Step 5	end	Return to privileged EXEC mode.
Step 6	show interface <i>interface-id</i> switchport	Verify your entries.

Using VTP

VTP is a Layer 2 messaging protocol that maintains VLAN configuration consistency by managing the addition, deletion, and renaming of VLANs on a network-wide basis. VTP minimizes misconfigurations and configuration inconsistencies that can cause several problems, such as duplicate VLAN names, incorrect VLAN-type specifications, and security violations.

Before you create VLANs, you must decide whether to use VTP in your network. Using VTP, you can make configuration changes centrally on a single switch, such as a Catalyst 2900 XL or Catalyst 3500 XL switch, and have those changes automatically communicated to all the other switches in the network. Without VTP, you cannot send information about VLANs to other switches.

The VTP Domain

A VTP domain (also called a VLAN management domain) consists of one switch or several interconnected switches under the same administrative responsibility. A switch can be in only one VTP domain. You make global VLAN configuration changes for the domain by using the CLI, Cluster Management software, or SNMP.

By default, a Catalyst 2900 XL or Catalyst 3500 XL switch is in the no-management-domain state until it receives an advertisement for a domain over a trunk link (a link that carries the traffic of multiple VLANs) or until you configure a domain name. The default VTP mode is server mode, but VLAN information is not propagated over the network until a domain name is specified or learned.

If the switch receives a VTP advertisement over a trunk link, it inherits the domain name and configuration revision number. The switch then ignores advertisements with a different domain name or an earlier configuration revision number.

When you make a change to the VLAN configuration on a VTP server, the change is propagated to all switches in the VTP domain. VTP advertisements are sent over all trunk connections, including Inter-Switch Link (ISL), IEEE 802.1Q, IEEE 802.10, and ATM LANE.

If you configure a switch for VTP transparent mode, you can create and modify VLANs, but the changes are not transmitted to other switches in the domain, and they affect only the individual switch.

For domain name and password configuration guidelines, see the [“Domain Names” section on page 8-18](#).

VTP Modes and Mode Transitions

You can configure a supported switch to be in one of the VTP modes listed in [Table 8-4](#).

Table 8-4 VTP Modes

VTP Mode	Description
VTP server	<p>In this mode, you can create, modify, and delete VLANs and specify other configuration parameters (such as VTP version) for the entire VTP domain. VTP servers advertise their VLAN configurations to other switches in the same VTP domain and synchronize their VLAN configurations with other switches based on advertisements received over trunk links.</p> <p>In VTP server mode, VLAN configurations are saved in nonvolatile RAM. VTP server is the default mode.</p>
VTP client	<p>In this mode, a VTP client behaves like a VTP server, but you cannot create, change, or delete VLANs on a VTP client.</p> <p>In VTP client mode, VLAN configurations are saved in nonvolatile RAM.</p>
VTP transparent	<p>In this mode, VTP transparent switches do not participate in VTP. A VTP transparent switch does not advertise its VLAN configuration and does not synchronize its VLAN configuration based on received advertisements. However, transparent switches do forward VTP advertisements that they receive from other switches. You can create, modify, and delete VLANs on a switch in VTP transparent mode.</p> <p>In VTP transparent mode, VLAN configurations are saved in nonvolatile RAM, but they are not advertised to other switches.</p>

Two configurations can cause a switch to automatically change its VTP mode:

- When the network is configured with more than the maximum 250 VLANs (some models support a maximum of 64 VLANs), the switch automatically changes from VTP server or client mode to VTP transparent mode. The switch then operates with the VLAN configuration that preceded the one that sent it into transparent mode.
- When a multi-VLAN port is configured on a supported switch in VTP server mode or client mode, the switch automatically changes to transparent mode.

The “[VTP Configuration Guidelines](#)” section on page 8-18 provides tips and caveats for configuring VTP.

VTP Advertisements

Each switch in the VTP domain sends periodic global configuration advertisements from each trunk port to a reserved multicast address. Neighboring switches receive these advertisements and update their VTP and VLAN configurations as necessary.



Note

Because trunk ports send and receive VTP advertisements, you must ensure that at least one trunk port is configured on the switch and that this trunk port is connected to the trunk port of a second switch. Otherwise, the switch cannot receive any VTP advertisements.

VTP advertisements distribute the following global domain information in VTP advertisements:

- VTP domain name
- VTP configuration revision number
- Update identity and update timestamp
- MD5 digest

VTP advertisements distribute the following VLAN information for each configured VLAN:

- VLAN ID
- VLAN name
- VLAN type
- VLAN state
- Additional VLAN configuration information specific to the VLAN type

VTP Version 2

VTP version 2 supports the following features not supported in version 1:

- Token Ring support—VTP version 2 supports Token Ring LAN switching and VLANs (Token Ring Bridge Relay Function [TrBRF] and Token Ring Concentrator Relay Function [TrCRF]). For more information about Token Ring VLANs, see the [“VLANs in the VTP Database” section on page 8-27](#).
- Unrecognized Type-Length-Value (TLV) support—A VTP server or client propagates configuration changes to its other trunks, even for TLVs it is not able to parse. The unrecognized TLV is saved in nonvolatile RAM when the switch is operating in VTP server mode.
- Version-Dependent Transparent Mode—In VTP version 1, a VTP transparent switch inspects VTP messages for the domain name and version and forwards a message only if the version and domain name match. Because only one domain is supported, VTP version 2 forwards VTP messages in transparent mode without checking the version and domain name.
- Consistency Checks—In VTP version 2, VLAN consistency checks (such as VLAN names and values) are performed only when you enter new information through the CLI, the Cluster Management software, or SNMP. Consistency checks are not performed when new information is obtained from a VTP message or when information is read from nonvolatile RAM. If the digest on a received VTP message is correct, its information is accepted without consistency checks.

VTP Pruning

Pruning increases available bandwidth by restricting flooded traffic to those trunk links that the traffic must use to reach the destination devices. Without VTP pruning, a switch floods broadcast, multicast, and unknown unicast traffic across all trunk links within a VTP domain even though receiving switches might discard them.

VTP pruning blocks unneeded flooded traffic to VLANs on trunk ports that are included in the pruning-eligible list. Only VLANs included in the pruning-eligible list can be pruned. By default, VLANs 2 through 1001 are pruning eligible on Catalyst 2900 XL and Catalyst 3500 XL trunk ports. If the VLANs are configured as pruning-ineligible, the flooding continues. VTP pruning is also supported with VTP version 1 and version 2.

Figure 8-3 shows a switched network with VTP pruning enabled. The broadcast traffic from Switch 1 is not forwarded to Switches 3, 5, and 6 because traffic for the Red VLAN has been pruned on the links indicated (port 5 on Switch 2 and port 4 on Switch 4).

Figure 8-3 Optimized Flooded Traffic with VTP Pruning

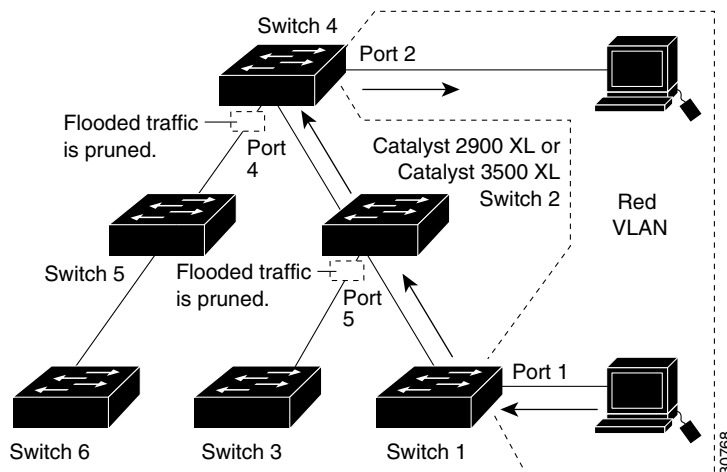

VTP Configuration Guidelines

The following sections describe the guidelines you should follow when configuring the VTP domain name and password and the VTP version number.

Domain Names

When configuring VTP for the first time, you must always assign a domain name. All switches in the VTP domain must also be configured with the same domain name. Switches in VTP transparent mode do not exchange VTP messages with other switches, and you do not need to configure a VTP domain name for them.

**Caution**

Do not configure a VTP domain if all switches are operating in VTP client mode. If you configure the domain, it is impossible to make changes to the VLAN configuration of that domain. Therefore, make sure you configure at least one switch in the VTP domain for VTP server mode.

Passwords

You can configure a password for the VTP domain, but it is not required. All domain switches must share the same password. Switches without a password or with the wrong password reject VTP advertisements.

**Caution**

The domain does not function properly if you do not assign the same password to each switch in the domain.

If you configure a VTP password for a domain, a Catalyst 2900 XL or Catalyst 3500 XL switch that is booted without a VTP configuration does not accept VTP advertisements until you configure it with the correct password. After the configuration, the switch accepts the next VTP advertisement that uses the same password and domain name in the advertisement.

If you are adding a new switch to an existing network that has VTP capability, the new switch learns the domain name only after the applicable password has been configured on the switch.

Upgrading from Previous Software Releases

When you upgrade from a software version that supports VLANs but does not support VTP, such as Cisco IOS Release 11.2(8)SA3, to a version that does support VTP, ports that belong to a VLAN retain their VLAN membership, and VTP enters transparent mode. The domain name becomes UPGRADE, and VTP does not propagate the VLAN configuration to other switches.

If you want the switch to propagate VLAN configuration information to other switches and to learn the VLANs enabled on the network, you must configure the switch with the correct domain name, the domain password, and change the VTP mode to VTP server.

VTP Version

Follow these guidelines when deciding which VTP version to implement:

- All switches in a VTP domain must run the same VTP version.
- A VTP version 2-capable switch can operate in the same VTP domain as a switch running VTP version 1 if version 2 is disabled on the version 2-capable switch. Version 2 is disabled by default.
- Do not enable VTP version 2 on a switch unless all of the switches in the same VTP domain are version-2-capable. When you enable version 2 on a switch, all of the version-2-capable switches in the domain enable version 2. If there is a version 1-only switch, it will not exchange VTP information with switches with version 2 enabled.
- If there are Token Ring networks in your environment (TrBRF and TrCRF), you must enable VTP version 2 for Token Ring VLAN switching to function properly. To run Token Ring and Token Ring-Net, disable VTP version 2.
- Enabling or disabling VTP pruning on a VTP server enables or disables VTP pruning for the entire VTP domain.

Default VTP Configuration

Table 8-5 shows the default VTP configuration.

Table 8-5 VTP Default Configuration

Feature	Default Value
VTP domain name	Null.
VTP mode	Server.
VTP version 2 enable state	Version 2 is disabled.
VTP password	None.
VTP pruning	Disabled.

Configuring VTP

You can configure VTP through the CLI by entering commands in the VLAN database command mode. When you enter the **exit** command in VLAN database mode, it applies all the commands that you entered. VTP messages are sent to other switches in the VTP domain, and you enter privileged EXEC mode.

If you are configuring VTP on a cluster member switch to a VLAN, first log in to the member switch by using the privileged EXEC **rcommand** command. For more information on how to use this command, refer to the *Catalyst 2900 Series XL and Catalyst 3500 Series XL Command Reference*.



Note

The Cisco IOS **end** and Ctrl-Z commands are not supported in VLAN database mode.

After you configure VTP, you must configure a trunk port so that the switch can send and receive VTP advertisements. For more information, see the “[How VLAN Trunks Work](#)” section on page 8-36.

Configuring VTP Server Mode

When a switch is in VTP server mode, you can change the VLAN configuration and have it propagated throughout the network.

Beginning in privileged EXEC mode, follow these steps to configure the switch for VTP server mode:

	Command	Purpose
Step 1	vlan database	Enter VLAN database mode.
Step 2	vtp domain <i>domain-name</i>	Configure a VTP administrative-domain name. The name can be from 1 to 32 characters. All switches operating in VTP server or client mode under the same administrative responsibility must be configured with the same domain name.
Step 3	vtp password <i>password-value</i>	(Optional) Set a password for the VTP domain. The password can be from 8 to 64 characters. If you configure a VTP password, the VTP domain does not function properly if you do not assign the same password to each switch in the domain.
Step 4	vtp server	Configure the switch for VTP server mode (the default).
Step 5	exit	Return to privileged EXEC mode.
Step 6	show vtp status	Verify the VTP configuration. In the display, check the VTP Operating Mode and the VTP Domain Name fields.

Configuring VTP Client Mode

When a switch is in VTP client mode, you cannot change its VLAN configuration. The client switch receives VTP updates from a VTP server in the VTP domain and then modifies its configuration accordingly.



Caution

Do not configure a VTP domain name if all switches are operating in VTP client mode. If you do so, it is impossible to make changes to the VLAN configuration of that domain. Therefore, make sure you configure at least one switch as the VTP server.

Beginning in privileged EXEC mode, follow these steps to configure the switch for VTP client mode:

	Command	Purpose
Step 1	vlan database	Enter VLAN database mode.
Step 2	vtp client	Configure the switch for VTP client mode. The default setting is VTP server.
Step 3	vtp domain <i>domain-name</i>	Configure a VTP administrative-domain name. The name can be from 1 to 32 characters. All switches operating in VTP server or client mode under the same administrative responsibility must be configured with the same domain name.
Step 4	vtp password <i>password-value</i>	(Optional) Set a password for the VTP domain. The password can be from 8 to 64 characters. If you configure a VTP password, the VTP domain does not function properly if you do not assign the same password to each switch in the domain.
Step 5	exit	Update the VLAN database, propagate it throughout the administrative domain, and return to privileged EXEC mode.
Step 6	show vtp status	Verify the VTP configuration. In the display, check the VTP Operating Mode field.

Disabling VTP (VTP Transparent Mode)

When you configure the switch for VTP transparent mode, you disable VTP on the switch. The switch then does not send VTP updates and does not act on VTP updates received from other switches. However, a VTP transparent switch does forward received VTP advertisements on all of its trunk links.

Beginning in privileged EXEC mode, follow these steps to configure the switch for VTP transparent mode:

	Command	Purpose
Step 1	vlan database	Enter VLAN database mode.
Step 2	vtp transparent	Configure the switch for VTP transparent mode. The default setting is VTP server. This step disables VTP on the switch.
Step 3	exit	Return to privileged EXEC mode.
Step 4	show vtp status	Verify the VTP configuration. In the display, check the VTP Operating Mode field.

Enabling VTP Version 2

VTP version 2 is disabled by default on VTP version 2-capable switches. When you enable VTP version 2 on a switch, every VTP version 2-capable switch in the VTP domain enables version 2.



Caution

VTP version 1 and VTP version 2 are not interoperable on switches in the same VTP domain. Every switch in the VTP domain must use the same VTP version. Do not enable VTP version 2 unless every switch in the VTP domain supports version 2.



Note

In a Token Ring environment, you must enable VTP version 2 for Token Ring VLAN switching to function properly.

For more information on VTP version configuration guidelines, see the [“VTP Version” section on page 8-19](#).

Beginning in privileged EXEC mode, follow these steps to enable VTP version 2:

	Command	Purpose
Step 1	<code>vlan database</code>	Enter VLAN configuration mode.
Step 2	<code>vtp v2-mode</code>	Enable VTP version 2 on the switch. VTP version 2 is disabled by default on VTP version 2-capable switches.
Step 3	<code>exit</code>	Update the VLAN database, propagate it throughout the administrative domain, and return to privileged EXEC mode.
Step 4	<code>show vtp status</code>	Verify that VTP version 2 is enabled. In the display, check the VTP V2 Mode field.

Disabling VTP Version 2

Beginning in privileged EXEC mode, follow these steps to disable VTP version 2:

	Command	Purpose
Step 1	<code>vlan database</code>	Enter VLAN configuration mode.
Step 2	<code>no vtp v2-mode</code>	Disable VTP version 2.
Step 3	<code>exit</code>	Update the VLAN database, propagate it throughout the administrative domain, and return to privileged EXEC mode.
Step 4	<code>show vtp status</code>	Verify that VTP version 2 is disabled. In the display, check the VTP V2 Mode field.

Enabling VTP Pruning

Pruning increases available bandwidth by restricting flooded traffic to those trunk links that the traffic must use to access the destination devices. You enable VTP pruning on a switch in VTP server mode.

Pruning is supported with VTP version 1 and version 2. If you enable pruning on the VTP server, it is enabled for the entire VTP domain.

Only VLANs included in the pruning-eligible list can be pruned. By default, VLANs 2 through 1001 are pruning eligible on Catalyst 2900 XL and Catalyst 3500 XL trunk ports. For information, see the [“Changing the Pruning-Eligible List”](#) section on page 8-42.

Beginning in privileged EXEC mode, follow these steps to enable VTP pruning:

	Command	Purpose
Step 1	vlan database	Enter VLAN configuration mode.
Step 2	vtp pruning	Enable pruning in the VTP administrative domain. By default, pruning is disabled. You only need to enable pruning on one switch in VTP server mode.
Step 3	exit	Update the VLAN database, propagate it throughout the administrative domain, and return to privileged EXEC mode.
Step 4	show vtp status	Verify your entries. In the display, check the VTP Pruning Mode field.

Monitoring VTP

You monitor VTP by displaying its configuration information: the domain name, the current VTP revision, and the number of VLANs. You can also display statistics about the advertisements sent and received by the switch.

Beginning in privileged EXEC mode, follow these steps to monitor VTP activity:

	Command	Purpose
Step 1	show vtp status	Display the VTP switch configuration information.
Step 2	show vtp counters	Display counters about VTP messages being sent and received.

VLANs in the VTP Database

You can set the following parameters when you add a new VLAN to or modify an existing VLAN in the VTP database:

- VLAN ID
- VLAN name
- VLAN type (Ethernet, Fiber Distributed Data Interface [FDDI], FDDI network entity title [NET], TrBRF or TrCRF, Token Ring, Token Ring-Net)
- VLAN state (active or suspended)
- Maximum transmission unit (MTU) for the VLAN
- Security Association Identifier (SAID)
- Bridge identification number for TrBRF VLANs
- Ring number for FDDI and TrCRF VLANs
- Parent VLAN number for TrCRF VLANs
- STP type for TrCRF VLANs
- VLAN number to use when translating from one VLAN type to another

The [“Default VLAN Configuration” section on page 8-28](#) lists the default values and possible ranges for each VLAN media type.

Token Ring VLANs

Although the Catalyst 2900 XL and Catalyst 3500 XL switches do not support Token Ring connections, a remote device such as a Catalyst 5000 series switch with Token Ring connections could be managed from one of the supported switches. Switches running this IOS release advertise information about the following Token Ring VLANs when running VTP version 2:

- Token Ring TrBRF VLANs
- Token Ring TrCRF VLANs

For more information on configuring Token Ring VLANs, refer to the *Catalyst 5000 Series Software Configuration Guide*.

VLAN Configuration Guidelines

Follow these guidelines when creating and modifying VLANs in your network:

- A maximum of 250 VLANs can be active on supported switches, but some models only support 64 VLANs. If VTP reports that there are 254 active VLANs, 4 of the active VLANs (1002 to 1005) are reserved for Token Ring and FDDI.
- Before you can create a VLAN, the switch must be in VTP server mode or VTP transparent mode. For information on configuring VTP, see the [“Configuring VTP” section on page 8-20](#).
- Switches running this IOS release do not support Token Ring or FDDI media. The switch does not forward FDDI, FDDI-Net, TrCRF, or TrBRF traffic, but it does propagate the VLAN configuration through VTP.

Default VLAN Configuration

[Table 8-6](#) through [Table 8-10](#) shows the default configuration for the different VLAN media types.



Note

Catalyst 2900 XL and Catalyst 3500 XL switches support Ethernet interfaces exclusively. Because FDDI and Token Ring VLANs are not locally supported, you configure FDDI and Token Ring media-specific characteristics only for VTP global advertisements to other switches.

Table 8-6 Ethernet VLAN Defaults and Ranges

Parameter	Default	Range
VLAN ID	1	1–1005
VLAN name	VLANxxxx, where xxxx is the VLAN ID	No range
802.10 SAID	100000+VLAN ID	1–4294967294
MTU size	1500	1500–18190
Translational bridge 1	0	0–1005
Translational bridge 2	0	0–1005
VLAN state	active	active, suspend

Table 8-7 FDDI VLAN Defaults and Ranges

Parameter	Default	Range
VLAN ID	1002	1–1005
VLAN name	VLANxxxx, where xxxx is the VLAN ID	No range
802.10 SAID	100000+VLAN ID	1–4294967294
MTU size	1500	1500–18190
Ring number	None	1–4095
Parent VLAN	0	0–1005
Translational bridge 1	0	0–1005
Translational bridge 2	0	0–1005
VLAN state	active	active, suspend

Table 8-8 FDDI-Net VLAN Defaults and Ranges

Parameter	Default	Range
VLAN ID	1004	1–1005
VLAN name	VLANxxxx, where xxxx is the VLAN ID	No range
802.10 SAID	100000+VLAN ID	1–4294967294
MTU size	1500	1500–18190
Bridge number	0	0–15
STP type	ieee	auto, ibm, ieee
Translational bridge 1	0	0–1005
Translational bridge 2	0	0–1005
VLAN state	active	active, suspend

Table 8-9 Token Ring (TrBRF) VLAN Defaults and Ranges

Parameter	Default	Range
VLAN ID	1005	1–1005
VLAN name	VLANxxxx, where xxxx is the VLAN ID	No range
802.10 SAID	100000+VLAN ID	1–4294967294
MTU size	VTPv1 1500; VTPv2 4472	1500–18190
Bridge number	VTPv1 0; VTPv2 user-specified	0–15
STP type	ibm	auto, ibm, ieee
Translational bridge 1	0	0–1005
Translational bridge 2	0	0–1005
VLAN state	active	active, suspend

Table 8-10 Token Ring (TrCRF) VLAN Defaults and Ranges

Parameter	Default	Range
VLAN ID	1003	1–1005
VLAN name	VLANxxxx, where xxxx is the VLAN ID	No range
802.10 SAID	100000+VLAN ID	1–4294967294
Ring Number	VTPv1 default 0; VTPv2 user-specified	1–4095
Parent VLAN	VTPv1 default 0; VTPv2 user-specified	0–1005
MTU size	VTPv1 default 1500; VTPv2 default 4472	1500–18190
Translational bridge 1	0	0–1005
Translational bridge 2	0	0–1005
VLAN state	active	active, suspend
Bridge mode	srb	srb, srt
ARE max hops	7	0–13
STE max hops	7	0–13
Backup CRF	disabled	disable; enable

Configuring VLANs in the VTP Database

You use the CLI **vlan database** VLAN database command to add, change, and delete VLANs. In VTP server or transparent mode, commands to add, change, and delete VLANs are written to the file `vlan.dat`, and you can display them by entering the privileged EXEC **show vlan** command. The `vlan.dat` file is stored in nonvolatile memory. The `vlan.dat` file is upgraded automatically, but you cannot return to an earlier version of Cisco IOS after you upgrade to this release.



Caution

You can cause inconsistency in the VLAN database if you attempt to manually delete the `vlan.dat` file. If you want to modify the VLAN configuration or VTP, use the VLAN database commands described in the *Catalyst 2900 Series XL and Catalyst 3500 Series XL Command Reference*.

You use the interface configuration command mode to define the port membership mode and add and remove ports from VLANs. The results of these commands are written to the running-configuration file, and you can display the file by entering the privileged EXEC **show running-config** command.



Note

VLANs can be configured to support a number of parameters that are not discussed in detail in this section. For complete information on the commands and parameters that control VLAN configuration, refer to the *Catalyst 2900 Series XL and Catalyst 3500 Series XL Command Reference*.

Adding a VLAN

Each VLAN has a unique, 4-digit ID that can be a number from 1 to 1001. To add a VLAN to the VLAN database, assign a number and name to the VLAN. For the list of default parameters that are assigned when you add a VLAN, see the [“Default VLAN Configuration” section on page 8-28](#).

If you do not specify the VLAN media type, the VLAN is an Ethernet VLAN.

Beginning in privileged EXEC mode, follow these steps to add an Ethernet VLAN:

	Command	Purpose
Step 1	vlan database	Enter VLAN database mode.
Step 2	vlan <i>vlan-id</i> name <i>vlan-name</i>	Add an Ethernet VLAN by assigning a number to it. If no name is entered for the VLAN, the default is to append the <i>vlan-id</i> to the word VLAN. For example, VLAN0004 could be a default VLAN name. If you do not specify the VLAN media type, the VLAN is an Ethernet VLAN.
Step 3	exit	Update the VLAN database, propagate it throughout the administrative domain, and return to privileged EXEC mode.
Step 4	show vlan name <i>vlan-name</i>	Verify the VLAN configuration.

Modifying a VLAN

Beginning in privileged EXEC mode, follow these steps to modify an Ethernet VLAN:

	Command	Purpose
Step 1	vlan database	Enter VLAN configuration mode.
Step 2	vlan <i>vlan-id</i> mtu <i>mtu-size</i>	Identify the VLAN, and change the MTU size.
Step 3	exit	Update the VLAN database, propagate it throughout the administrative domain, and return to privileged EXEC mode.
Step 4	show vlan <i>vlan-id</i>	Verify the VLAN configuration.

Deleting a VLAN from the Database

When you delete a VLAN from a switch that is in VTP server mode, the VLAN is removed from all switches in the VTP domain. When you delete a VLAN from a switch that is in VTP transparent mode, the VLAN is deleted only on that specific switch.

You cannot delete the default VLANs for the different media types: Ethernet VLAN 1 and FDDI or Token Ring VLANs 1002 to 1005.



Caution

When you delete a VLAN, any ports assigned to that VLAN become inactive. They remain associated with the VLAN (and thus inactive) until you assign them to a new VLAN.

Beginning in privileged EXEC mode, follow these steps to delete a VLAN on the switch:

	Command	Purpose
Step 1	vlan database	Enter VLAN configuration mode.
Step 2	no vlan <i>vlan-id</i>	Remove the VLAN by using the VLAN ID.
Step 3	exit	Update the VLAN database, propagate it throughout the administrative domain, and return to privileged EXEC mode.
Step 4	show vlan brief	Verify the VLAN removal.

Assigning Static-Access Ports to a VLAN

By default, all ports are static-access ports assigned to VLAN 1, which is the default management VLAN. If you are assigning a port on a cluster member switch to a VLAN, first log in to the member switch by using the privileged EXEC **rcommand** command. For more information on how to use this command, refer to the *Catalyst 2900 Series XL and Catalyst 3500 Series XL Command Reference*.

Beginning in privileged EXEC mode, follow these steps to assign a port to a VLAN in the VTP database:

	Command	Purpose
Step 1	configure terminal	Enter global configuration mode.
Step 2	interface <i>interface</i>	Enter interface configuration mode, and define the interface to be added to the VLAN.
Step 3	switchport mode access	Define the VLAN membership mode for this port.
Step 4	switchport access vlan 3	Assign the port to the VLAN.
Step 5	exit	Return to privileged EXEC mode.
Step 6	show interface <i>interface-id</i> switchport	Verify the VLAN configuration. In the display, check the Operation Mode, Access Mode VLAN, and the Priority for Untagged Frames fields.

How VLAN Trunks Work

A trunk is a point-to-point link that transmits and receives traffic between switches or between switches and routers. Trunks carry the traffic of multiple VLANs and can extend VLANs across an entire network. 100BASE-T and Gigabit Ethernet trunks use Cisco Inter-Switch Link (ISL), the default protocol, or industry-standard IEEE 802.1Q to carry traffic for multiple VLANs over a single link.

Figure 8-4 shows a network of switches that are connected by ISL trunks.

Figure 8-4 Catalyst 2900 XL and Catalyst 3500 XL Switches in an ISL Trunking Environment

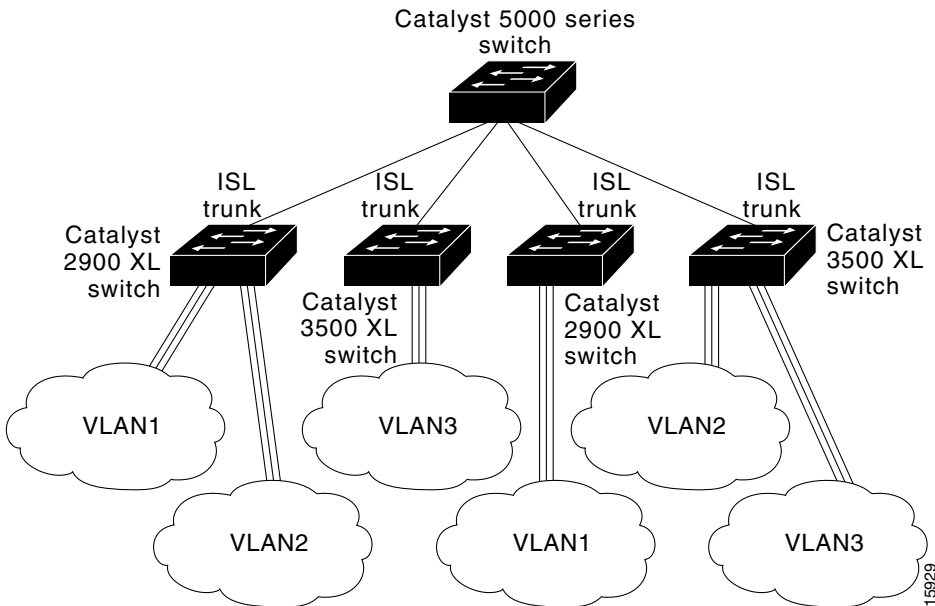

IEEE 802.1Q Configuration Considerations

IEEE 802.1Q trunks impose some limitations on the trunking strategy for a network. The following restrictions apply when using 802.1Q trunks:

- Make sure the native VLAN for an 802.1Q trunk is the same on both ends of the trunk link. If the native VLAN on one end of the trunk is different from the native VLAN on the other end, spanning-tree loops might result.
- Disabling STP on the native VLAN of an 802.1Q trunk without disabling STP on every VLAN in the network can potentially cause STP loops. We recommend that you leave STP enabled on the native VLAN of an 802.1Q trunk or disable STP on every VLAN in the network. Make sure your network is loop-free before disabling STP.

Trunks Interacting with Other Features

ISL, IEEE 802.1Q, and ATM trunking interacts with other switch features as described in [Table 8-11](#).

Table 8-11 *Trunks Interacting with Other Features*

Switch Feature	Trunk Port Interaction
Port monitoring	A trunk port cannot be a monitor port. A static-access port can monitor the traffic of its VLAN on a trunk port.
Network port	When configured as a network port, a trunk port serves as the network port for all VLANs associated with the port. A network port receives all unknown unicast traffic on a VLAN.
Secure ports	A trunk port cannot be a secure port.

Table 8-11 Trunks Interacting with Other Features (continued)

Switch Feature	Trunk Port Interaction
Blocking unicast and multicast packets on a trunk	The port block interface configuration command can be used to block the forwarding of unknown unicast and multicast packets to VLANs on a trunk. However, if the trunk port is acting as a network port, unknown unicast packets cannot be blocked.
Port grouping	<p>ISL and 802.1Q trunks can be grouped into EtherChannel port groups, but all trunks in the group must have the same configuration. ATM ports are always trunk ports but cannot be part of an EtherChannel port group.</p> <p>When a group is first created, all ports follow the parameters set for the first port to be added to the group. If you change the configuration of one of the following parameters, the switch propagates the setting you entered to all ports in the group:</p> <ul style="list-style-type: none"> • Allowed-VLAN list. • STP path cost for each VLAN. • STP port priority for each VLAN. • STP Port Fast setting. • Trunk status: if one port in a port group ceases to be a trunk, all ports cease to be trunks.

Configuring a Trunk Port

You cannot have multi-VLAN and trunk ports configured on the same switch. For information on trunk port interactions with other features, see the [“Trunks Interacting with Other Features”](#) section on page 8-37.



Note

Because trunk ports send and receive VTP advertisements, you must ensure that at least one trunk port is configured on the switch and that this trunk port is connected to the trunk port of a second switch. Otherwise, the switch cannot receive any VTP advertisements.

Beginning in privileged EXEC mode, follow these steps to configure a port as an ISL or 802.1Q trunk port:

	Command	Purpose
Step 1	configure terminal	Enter global configuration mode.
Step 2	interface <i>interface_id</i>	Enter the interface configuration mode and the port to be configured for trunking.
Step 3	switchport mode trunk	Configure the port as a VLAN trunk.
Step 4	switchport trunk encapsulation {isl dot1q }	Configure the port to support ISL or 802.1Q encapsulation. You must configure each end of the link with the same encapsulation type.
Step 5	end	Return to privileged EXEC mode.
Step 6	show interface <i>interface-id</i> switchport	Verify your entries. In the display, check the Operational Mode and the Operational Trunking Encapsulation fields.
Step 7	copy running-config startup-config	Save the configuration.



Note

This software release does not support trunk negotiation through the Dynamic Trunk Protocol (DTP), formerly known as Dynamic ISL (DISL). If you are connecting a trunk port to a Catalyst 5000 switch or other DTP device, use the non-negotiate option on the DTP-capable device so that the switch port does not generate DTP frames.

Disabling a Trunk Port

You can disable trunking on a port by returning it to its default static-access mode. Beginning in privileged EXEC mode, follow these steps to disable trunking on a port:

	Command	Purpose
Step 1	configure terminal	Enter global configuration mode.
Step 2	interface <i>interface_id</i>	Enter the interface configuration mode and the port to be added to the VLAN.
Step 3	no switchport mode	Return the port to its default static-access mode.
Step 4	end	Return to privileged EXEC.
Step 5	show interface <i>interface-id</i> switchport	Verify your entries. In the display, check the Negotiation of Trunking field.

Defining the Allowed VLANs on a Trunk

By default, a trunk port sends to and receives traffic from all VLANs in the VLAN database. All VLANs, 1 to 1005, are allowed on each trunk. However, you can remove VLANs from the allowed list, preventing traffic from those VLANs from passing over the trunk. To restrict the traffic a trunk carries, use the **remove** *vlan-list* parameter to remove specific VLANs from the allowed list.

A trunk port can become a member of a VLAN if the VLAN is enabled, if VTP knows of the VLAN, and if the VLAN is in the allowed list for the port. When VTP detects a newly enabled VLAN and the VLAN is in the allowed list for a trunk port, the trunk port automatically becomes a member of the enabled VLAN. When VTP detects a new VLAN and the VLAN is not in the allowed list for a trunk port, the trunk port does not become a member of the new VLAN.

Beginning in privileged EXEC mode, follow these steps to modify the allowed list of a ISL or 802.1Q trunk:

	Command	Purpose
Step 1	configure terminal	Enter global configuration mode.
Step 2	interface <i>interface_id</i>	Enter interface configuration mode and the port to be added to the VLAN.
Step 3	switchport mode trunk	Configure VLAN membership mode for trunks.
Step 4	switchport trunk allowed vlan remove <i>vlan-list</i>	Define the VLANs that are <i>not</i> allowed to transmit and receive on the port. The <i>vlan-list</i> parameter is a range of VLAN IDs. Separate nonconsecutive VLAN IDs with a comma and no spaces; use a hyphen to designate a range of IDs. Valid IDs are from 2 to 1001.
Step 5	end	Return to privileged EXEC.
Step 6	show interface <i>interface-id</i> switchport allowed-vlan	Verify your entries.
Step 7	copy running-config startup-config	Save the configuration.

Changing the Pruning-Eligible List

The pruning-eligible list applies only to trunk ports. Each trunk port has its own eligibility list. VTP Pruning must be enabled for the following procedure to take effect. The [“Enabling VTP Pruning”](#) section on page 8-25 describes how to enable VTP pruning.

Beginning in privileged EXEC mode, follow these steps to remove VLANs from the pruning-eligible list on a trunk port:

	Command	Purpose
Step 1	configure terminal	Enter global configuration mode.
Step 2	interface <i>interface-id</i>	Enter interface configuration mode, and select the trunk port for which VLANs should be pruned.
Step 3	switchport trunk pruning vlan remove <i>vlan-id</i>	Enter the VLANs to be removed from the pruning-eligible list. Separate nonconsecutive VLAN IDs with a comma and no spaces; use a hyphen to designate a range of IDs. Valid IDs are from 2 to 1001. VLANs that are pruning-ineligible receive flooded traffic.
Step 4	exit	Return to privileged EXEC mode.
Step 5	show interface <i>interface-id</i> switchport	Verify your settings.

Configuring the Native VLAN for Untagged Traffic

A trunk port configured with 802.1Q tagging can receive both tagged and untagged traffic. By default, the switch forwards untagged traffic with the native VLAN configured for the port. The native VLAN is VLAN 1 by default.



Note

The native VLAN can be assigned any VLAN ID, and it is not dependent on the management VLAN.

For information about 802.1Q configuration issues, see the [“IEEE 802.1Q Configuration Considerations” section on page 8-37](#).

Beginning in privileged EXEC mode, follow these steps to configure the native VLAN on an 802.1Q trunk:

	Command	Purpose
Step 1	configure terminal	Enter global configuration mode.
Step 2	interface <i>interface-id</i>	Enter interface configuration mode, and define the interface that is configured as the 802.1Q trunk.
Step 3	switchport trunk native vlan <i>vlan-id</i>	Configure the VLAN that is sending and receiving untagged traffic on the trunk port. Valid IDs are from 1 to 1001.
Step 4	show interface <i>interface-id</i> switchport	Verify your settings.

If a packet has a VLAN ID the same as the outgoing port native VLAN ID, the packet is transmitted untagged; otherwise, the switch transmits the packet with a tag.

Configuring 802.1p Class of Service

The Catalyst 2900 XL and Catalyst 3500 XL switches provide quality of service (QoS)-based IEEE 802.1p class of service (CoS) values. QoS uses classification and scheduling to transmit network traffic from the switch in a predictable manner. QoS classifies frames by assigning priority-indexed CoS values to them and gives preference to higher-priority traffic such as telephone calls.

How Class of Service Works

Before you set up 802.1p CoS on a Catalyst 2900 XL or Catalyst 3500 XL switch that operates with the Catalyst 6000 family of switches, refer to the Catalyst 6000 documentation. There are differences in the 802.1p implementation, and they should be understood to ensure compatibility.

Port Priority

Frames received from users in the administratively-defined VLANs are classified or *tagged* for transmission to other devices. Based on rules you define, a unique identifier (the tag) is inserted in each frame header before it is forwarded. The tag is examined and understood by each device before any broadcasts or transmissions to other switches, routers, or end stations. When the frame reaches the last switch or router, the tag is removed before the frame is transmitted to the target end station. VLANs that are assigned on trunk or access ports without identification or a tag are called *native* or *untagged* frames.

For ISL or IEEE 802.1Q frames with tag information, the priority value from the header frame is used. For native frames, the default priority of the input port is used.

Port Scheduling

Each port on the switch has a single receive queue buffer (the *ingress* port) for incoming traffic. When an untagged frame arrives, it is assigned the value of the port as its port default priority. You assign this value by using the CLI or CMS software. A tagged frame continues to use its assigned CoS value when it passes through the ingress port.

CoS configures each transmit port (the *egress* port) with a normal-priority transmit queue and a high-priority transmit queue, depending on the frame tag or the port information. Frames in the normal-priority queue are forwarded only after frames in the high-priority queue are forwarded.

Table 8-12 shows the two categories of switch transmit queues.

Table 8-12 Transmit Queue Information

Transmit Queue Category ¹	Transmit Queues
Catalyst 2900 XL switches, Catalyst 2900 XL Ethernet modules (802.1p user priority)	<p>Frames with a priority value of 0 through 3 are sent to a normal-priority queue.</p> <p>Frames with a priority value of 4 through 7 are sent to a high-priority queue.</p>
Catalyst 3500 XL switches, Gigabit Ethernet modules (802.1p user priority)	<p>Frames with a priority value of 0 through 3 are sent to a normal-priority queue.</p> <p>Frames with a priority value of 4 through 7 are sent to a high-priority queue.</p>

1. Catalyst 2900 XL switches with 4 MB of DRAM and the WS-X2914-XL and the WS-X2922-XL modules only have one transmit queue and do not support QoS.

Configuring the CoS Port Priorities

Beginning in privileged EXEC mode, follow these steps to set the port priority for untagged (native) Ethernet frames:

	Command	Purpose
Step 1	configure terminal	Enter global configuration mode.
Step 2	interface <i>interface</i>	Enter the interface to be configured.
Step 3	switchport priority default <i>default-priority-id</i>	Set the port priority on the interface. If you assign a priority level from 0 to 3, frames are forwarded to the normal priority queue of the output port. If you assign a priority level from 4 to 7, frames are forwarded to the high-priority queue of the output port.
Step 4	end	Return to privileged EXEC mode.
Step 5	show interface <i>interface-id</i> switchport	Verify your entries. In the display, check the Priority for Untagged Frames field.

Load Sharing Using STP

Load sharing divides the bandwidth supplied by parallel trunks connecting switches. To avoid loops, STP normally blocks all but one parallel link between switches. With load sharing, you divide the traffic between the links according to which VLAN the traffic belongs to.

You configure load sharing on trunk ports by using STP port priorities or STP path costs. For load sharing using STP port priorities, both load-sharing links must be connected to the same switch. For load sharing using STP path costs, each load-sharing link can be connected to the same switch or to two different switches.

For more information about STP, see the [“Configuring STP” section on page 6-24](#).

Load Sharing Using STP Port Priorities

When two ports on the same switch form a loop, the STP port priority setting determines which port is enabled and which port is in standby mode. You can set the priorities on a parallel trunk port so that the port carries all the traffic for a given VLAN. The trunk port with the higher priority (lower values) for a VLAN is forwarding traffic for that VLAN. The trunk port with the lower priority (higher values) for the same VLAN remains in a blocking state for that VLAN. One trunk port transmits or receives all traffic for the VLAN.

Figure 8-5 shows two trunks connecting supported switches. In this example, the switches are configured as follows:

- VLANs 8 through 10 are assigned a port priority of 10 on trunk 1.
- VLANs 3 through 6 retain the default port priority of 128 on trunk 1.
- VLANs 3 through 6 are assigned a port priority of 10 on trunk 2.
- VLANs 8 through 10 retain the default port priority of 128 on trunk 2.

In this way, trunk 1 carries traffic for VLANs 8 through 10, and trunk 2 carries traffic for VLANs 3 through 6. If the active trunk fails, the trunk with the lower priority takes over and carries the traffic for all of the VLANs. No duplication of traffic occurs over any trunk port.

Figure 8-5 Load Sharing by Using STP Port Priorities

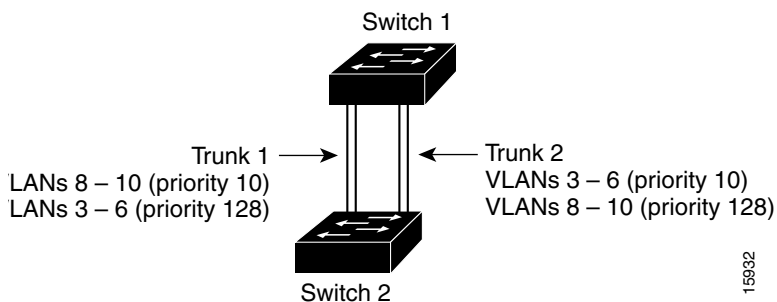

Configuring STP Port Priorities and Load Sharing

Beginning in privileged EXEC mode, follow these steps to configure the network shown in [Figure 8-5](#):

	Command	Purpose
Step 1	vlan database	On Switch 1, enter VLAN configuration mode.
Step 2	vtp domain <i>domain-name</i>	Configure a VTP administrative domain. The domain name can be from 1 to 32 characters.
Step 3	vtp server	Configure Switch 1 as the VTP server.
Step 4	exit	Return to privileged EXEC mode.
Step 5	show vtp status	Verify the VTP configuration on both Switch 1 and Switch 2. In the display, check the VTP Operating Mode and the VTP Domain Name fields.
Step 6	show vlan	Verify that the VLANs exist in the database on Switch 1.
Step 7	configure terminal	Enter global configuration mode.
Step 8	interface fa0/1	Enter interface configuration mode, and define Fa0/1 as the interface to be configured as a trunk.
Step 9	switchport mode trunk	Configure the port as a trunk port. The trunk defaults to ISL trunking.
Step 10	end	Return to privileged EXEC mode.
Step 11	show interface fa0/1 switchport	Verify the VLAN configuration.
Step 12		Repeat Steps 7 through 11 on Switch 1 for interface Fa0/2.
Step 13		Repeat Steps 7 through 11 on Switch 2 to configure the trunk ports on interface Fa0/1 and Fa0/2.
Step 14	show vlan	When the trunk links come up, VTP passes the VTP and VLAN information to Switch 2. Verify the Switch 2 has learned the VLAN configuration.
Step 15	configure terminal	Enter global configuration mode on Switch 1.

	Command	Purpose
Step 16	interface fa0/1	Enter interface configuration mode, and define the interface to set the STP port priority.
Step 17	spanning-tree vlan 8 9 10 port-priority 10	Assign the port priority of 10 for VLANs 8, 9, and 10.
Step 18	end	Return to global configuration mode.
Step 19	interface fa0/2	Enter interface configuration mode, and define the interface to set the STP port priority.
Step 20	spanning-tree vlan 3 4 5 6 port priority 10	Assign the port priority of 10 for VLANs 3, 4, 5, and 6.
Step 21	exit	Return to privileged EXEC mode.
Step 22	show running-config	Verify your entries.

Load Sharing Using STP Path Cost

You can configure parallel trunks to share VLAN traffic by setting different path costs on a trunk and associating the path costs with different sets of VLANs. The VLANs keep the traffic separate; because no loops exist, STP does not disable the ports; and redundancy is maintained in the event of a lost link.

In [Figure 8-6](#), trunk ports 1 and 2 are 100BASE-T ports. The path costs for the VLANs are assigned as follows:

- VLANs 2 through 4 are assigned a path cost of 30 on trunk port 1.
- VLANs 8 through 10 retain the default 100BASE-T path cost on trunk port 1 of 19.
- VLANs 8 through 10 are assigned a path cost of 30 on trunk port 2.
- VLANs 2 through 4 retain the default 100BASE-T path cost on trunk port 2 of 19.

Figure 8-6 Load-Sharing Trunks with Traffic Distributed by Path Cost

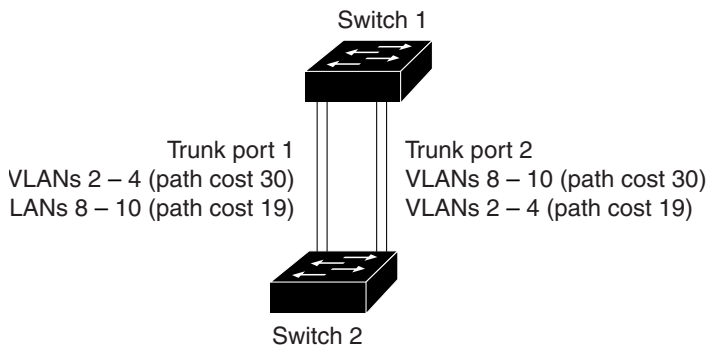

16591

Beginning in privileged EXEC mode, follow these steps to configure the network shown in [Figure 8-6](#):

	Command	Purpose
Step 1	configure terminal	Enter global configuration mode on Switch 1.
Step 2	interface fa0/1	Enter interface configuration mode, and define Fa0/1 as the interface to be configured as a trunk.
Step 3	switchport mode trunk	Configure the port as a trunk port. The trunk defaults to ISL trunking.
Step 4	end	Return to global configuration mode.
Step 5		Repeat Steps 2 through 4 on Switch 1 interface Fa0/2.
Step 6	show running-config	Verify your entries. In the display, make sure that interface Fa0/1 and Fa0/2 are configured as trunk ports.
Step 7	show vlan	When the trunk links come up, Switch 1 receives the VTP information from the other switches. Verify that Switch 1 has learned the VLAN configuration.
Step 8	configure terminal	Enter global configuration mode.
Step 9	interface fa0/1	Enter interface configuration mode, and define Fa0/1 as the interface to set the STP cost.
Step 10	spanning-tree vlan 2 3 4 cost 30	Set the spanning-tree path cost to 30 for VLANs 2, 3, and 4.
Step 11	end	Return to global configuration mode.
Step 12		Repeat Steps 9 through 11 on Switch 1 interface Fa0/2, and set the spanning-tree path cost to 30 for VLANs 8, 9, and 10.
Step 13	exit	Return to privileged EXEC mode.
Step 14	show running-config	Verify your entries. In the display, verify that the path costs are set correctly for interface Fa0/1 and Fa0/2.

How the VMPS Works

A switch running this software release acts as a client to the VLAN Membership Policy Server (VMPS) and communicates with it through the VLAN Query Protocol (VQP). When the VMPS receives a VQP request from a client switch, it searches its database for a MAC-address-to-VLAN mapping. The server response is based on this mapping and whether or not the server is in secure mode. Secure mode determines whether the server shuts down the port when a VLAN is not allowed on it or just denies the port access to the VLAN.

In response to a request, the VMPS takes one of the following actions:

- If the assigned VLAN is restricted to a group of ports, the VMPS verifies the requesting port against this group and responds as follows:
 - If the VLAN is allowed on the port, the VMPS sends the VLAN name to the client in response.
 - If the VLAN is not allowed on the port, and the VMPS is not in secure mode, the VMPS sends an *access-denied* response.
 - If the VLAN is not allowed on the port, and the VMPS is in secure mode, the VMPS sends a *port-shutdown* response.
- If the VLAN in the database does not match the current VLAN on the port and active hosts exist on the port, the VMPS sends an *access-denied* or a *port-shutdown* response, depending on the secure mode of the VMPS.

If the switch receives an *access-denied* response from the VMPS, it continues to block traffic from the MAC address to or from the port. The switch continues to monitor the packets directed to the port and sends a query to the VMPS when it identifies a new address. If the switch receives a *port-shutdown* response from the VMPS, it disables the port. The port must be manually reenabled by using the CLI, Cluster Management software, or SNMP.

You can also use an explicit entry in the configuration table to deny access to specific MAC addresses for security reasons. If you enter the **none** keyword for the VLAN name, the VMPS sends an *access-denied* or *port-shutdown* response.

Dynamic Port VLAN Membership

A dynamic (nontrunking) port on the switch can belong to only one VLAN. When the link comes up, the switch does not forward traffic to or from this port until the VMPS provides the VLAN assignment. The VMPS receives the source MAC address from the first packet of a new host connected to the dynamic port and attempts to match the MAC address to a VLAN in the VMPS database.

If there is a match, the VMPS sends the VLAN number for that port. If the client switch was not previously configured, it uses the domain name from the first VTP packet it receives on its trunk port from the VMPS. If the client switch was previously configured, it includes its domain name in the query packet to the VMPS to obtain its VLAN number. The VMPS verifies that the domain name in the packet matches its own domain name before accepting the request and responds to the client with the assigned VLAN number for the client.

If there is no match, the VMPS either denies the request or shuts down the port (depending on the VMPS secure mode setting). For more information on possible VMPS responses, see the [“How the VMPS Works” section on page 8-52](#).

Multiple hosts (MAC addresses) can be active on a dynamic port if they are all in the same VLAN; however, the VMPS shuts down a dynamic port if more than 20 hosts are active on the port.

If the link goes down on a dynamic port, the port returns to an isolated state and does not belong to a VLAN. Any hosts that come online through the port are checked again with the VMPS before the port is assigned to a VLAN.

VMPS Database Configuration File

The VMPS contains a database configuration file that you create. This ASCII text file is stored on a switch-accessible TFTP server that functions as a VMPS server. The file contains VMPS information, such as the domain name, the fall-back VLAN name, and the MAC address-to-VLAN mapping. A Catalyst 2900 XL or Catalyst 3500 XL switch running this software release cannot act as the VMPS. Use a Catalyst 5000 series switch as the VMPS.

The VMPS database configuration file on the server must use the Catalyst 2900 XL and Catalyst 3500 XL convention for naming ports. For example, Fa0/5 is fixed-port number 5.

If the switch is a cluster member, the command switch adds the name of the switch before the Fa. For example, es3%Fa02 refers to fixed 10/100 port 2 on member switch 3. These naming conventions must be used in the VMPS database configuration file when it is configured to support a cluster.

You can configure a fallback VLAN name. If you connect a device with a MAC address that is not in the database, the VMPS sends the fallback VLAN name to the client. If you do not configure a fallback VLAN and the MAC address does not exist in the database, the VMPS sends an *access-denied* response. If the VMPS is in secure mode, it sends a *port-shutdown* response.

The following example shows a sample VMPS database configuration file as it appears on a Catalyst 5000 series switch.

```
!vmps domain <domain-name>
! The VMPS domain must be defined.
!vmps mode { open | secure }
! The default mode is open.
!vmps fallback <vlan-name>
!vmps no-domain-req { allow | deny }
!
! The default value is allow.
vmps domain WBU
vmps mode open
vmps fallback default
vmps no-domain-req deny
!
!
!MAC Addresses
!
vmps-mac-addr
!
```

```

! address <addr> vlan-name <vlan_name>
!
address 0012.2233.4455 vlan-name hardware
address 0000.6509.a080 vlan-name hardware
address aabb.cccd.eeff vlan-name Green
address 1223.5678.9abc vlan-name ExecStaff
address fedc.ba98.7654 vlan-name --NONE--
address fedc.ba23.1245 vlan-name Purple
!
!Port Groups
!
!vmps-port-group <group-name>
! device <device-id> { port <port-name> | all-ports }
!
vmps-port-group WiringCloset1
  device 192.168.1.1 port Fa1/3
  device 172.16.1.1 port Fa1/4
vmps-port-group "Executive Row"
  device 192.168.2.2 port es5%Fa0/1
  device 192.168.2.2 port es5%Fa0/2
  device 192.168.2.3 all-ports
!
!VLAN groups
!
!vmps-vlan-group <group-name>
! vlan-name <vlan-name>
!
vmps-vlan-group Engineering
  vlan-name hardware
  vlan-name software
!
!VLAN port Policies
!
!vmps-port-policies {vlan-name <vlan_name> | vlan-group <group-name> }
! { port-group <group-name> | device <device-id> port <port-name> }
!
vmps-port-policies vlan-group Engineering
  port-group WiringCloset1
vmps-port-policies vlan-name Green
  device 192.168.1.1 port Fa0/9
vmps-port-policies vlan-name Purple
  device 192.168.2.2 port Fa0/10
  port-group "Executive Row"

```

VMPS Configuration Guidelines

The following guidelines and restrictions apply to dynamic port VLAN membership:

- You must configure the VMPS before you configure ports as dynamic.
- The communication between a cluster of switches and VMPS is managed by the command switch and includes port-naming conventions that are different from standard port names. For the cluster-based port-naming conventions, see the “[VMPS Database Configuration File](#)” section on page 8-54.
- When you configure a port as dynamic, the spanning-tree Port Fast feature is automatically enabled for that port. The Port Fast mode accelerates the process of bringing the port into the forwarding state. You can disable Port Fast mode on a dynamic port.
- Secure ports cannot be dynamic ports. You must disable port security on the port before it becomes dynamic.
- Trunk ports cannot be dynamic ports, but it is possible to enter the **switchport access vlan dynamic** interface configuration command for a trunk port. In this case, the switch retains the setting and applies it if the port is later configured as an access port.

You must turn off trunking on the port before the dynamic access setting takes effect.

- Dynamic ports cannot be network ports or monitor ports.
- The VTP management domain of the VMPS client and the VMPS server must be the same.

Default VMPS Configuration

Table 8-13 shows the default VMPS and dynamic port configuration on client switches.

Table 8-13 Default VMPS Client and Dynamic Port Configuration

Feature	Default Configuration
VMPS domain server	None
VMPS reconfirm interval	60 minutes
VMPS server retry count	3
Dynamic ports	None configured

Configuring Dynamic VLAN Membership

You must enter the IP address of the Catalyst 5000 switch or the other device acting as the VMPS to configure the Catalyst 2900 XL or Catalyst 3500 XL switch as a client. If the VMPS is being defined for a cluster of switches, enter the address on the command switch.

Beginning in privileged EXEC mode, follow these steps to enter the IP address of the VMPS:

	Command	Purpose
Step 1	configure terminal	Enter global configuration mode.
Step 2	vmps server <i>ipaddress</i> primary	Enter the IP address of the switch acting as the primary VMPS server.
Step 3	vmps server <i>ipaddress</i>	Enter the IP address for the switch acting as a secondary VMPS server. You can enter up to three secondary server addresses.
Step 4	end	Return to privileged EXEC mode.
Step 5	show vmps	Verify the VMPS server entry. In the display, check the VMPS Domain Server field.

Configuring Dynamic Ports on VMPS Clients

If you are configuring a port on a member switch as a dynamic port, first log into the member switch by using the privileged EXEC **rcommand** command. For more information on how to use this command, refer to the *Catalyst 2900 Series XL and Catalyst 3500 Series XL Command Reference*.



Caution

Dynamic port VLAN membership is for end stations. Connecting dynamic ports to other switches can cause a loss of connectivity.

Beginning in privileged EXEC mode, follow these steps to configure a dynamic port on the VMPS client switches:

	Command	Purpose
Step 1	configure terminal	Enter global configuration mode.
Step 2	interface <i>interface</i>	Enter interface configuration mode and the switch port that is connected to the end station.
Step 3	switchport mode access	Set the port to access mode.
Step 4	switchport access vlan dynamic	Configure the port as eligible for dynamic VLAN membership. The dynamic-access port must be connected to an end station.
Step 5	end	Return to privileged EXEC mode.
Step 6	show interface <i>interface</i> switchport	Verify the entry. In the display, check the Operational Mode field.

The switch port that is connected to the VMPS server should be configured as a trunk. For more information, see the [“Configuring a Trunk Port” section on page 8-38](#).

Reconfirming VLAN Memberships

Beginning in privileged EXEC mode, follow these steps to confirm the dynamic port VLAN membership assignments that the switch has received from the VMPS:

	Command	Purpose
Step 1	vmps reconfirm	Reconfirm dynamic port VLAN membership.
Step 2	show vmps	Verify the dynamic VLAN reconfirmation status.

Changing the Reconfirmation Interval

VMPS clients periodically reconfirm the VLAN membership information received from the VMPS. You can set the number of minutes after which reconfirmation occurs.

If you are configuring a member switch in a cluster, this parameter must be equal to or greater than the reconfirmation setting on the command switch. In addition, you must first log into the member switch by using the privileged EXEC **rcommand** command. For more information about this command, refer to the *Catalyst 2900 Series XL and Catalyst 3500 Series XL Command Reference*.

Beginning in privileged EXEC mode, follow these steps to change the reconfirmation interval:

	Command	Purpose
Step 1	configure terminal	Enter global configuration mode.
Step 2	vmps reconfirm <i>minutes</i>	Enter the number of minutes between reconfirmations of the dynamic VLAN membership. Enter a number from 1 to 120. The default is 60 minutes.
Step 3	end	Return to privileged EXEC mode.
Step 4	show vmps	Verify the dynamic VLAN reconfirmation status. In the display, check the Reconfirm Interval field.

Changing the Retry Count

Beginning in privileged EXEC mode, follow these steps to change the number of times that the switch attempts to contact the VMPS before querying the next server:

	Command	Purpose
Step 1	configure terminal	Enter global configuration mode.
Step 2	vmps retry count	Change the retry count. The retry range is from 1 to 10; the default is 3.
Step 3	exit	Return to privileged EXEC mode.
Step 4	show vmps	Verify your entry. In the display, check the Server Retry Count field.

Administering and Monitoring the VMPS

You can display information about the VMPS by using the privileged EXEC **show vmps** command. The switch displays the following information about the VMPS:

VMPS VQP Version	The version of VQP used to communicate with the VMPS. The switch queries the VMPS using version 1 of VQP.
Reconfirm Interval	The number of minutes the switch waits before reconfirming the VLAN-to-MAC-address assignments.
Server Retry Count	The number of times VQP resends a query to the VMPS. If no response is received after this many tries, the switch starts to query the secondary VMPS.
VMPS domain server	The IP address of the configured VLAN membership policy servers. The switch sends queries to the one marked <i>current</i> . The one marked <i>primary</i> is the primary server.
VMPS Action	The result of the most recent reconfirmation attempt. This can happen automatically when the reconfirmation interval expired, or you can force it by entering the privileged EXEC vmps reconfirm command or its Cluster Management software or SNMP equivalent.

Troubleshooting Dynamic Port VLAN Membership

The VMPS shuts down a dynamic port under these conditions:

- The VMPS is in secure mode, and it will not allow the host to connect to the port. The VMPS shuts down the port to prevent the host from connecting to the network.
- More than 20 active hosts reside on a dynamic port.

To reenable a shut-down dynamic port, enter the interface configuration **no shutdown** command.

Dynamic Port VLAN Membership Configuration Example

Figure 8-7 shows a network with a VMPS server switch and VMPS client switches with dynamic ports. In this example, these assumptions apply:

- The VMPS server and the VMPS client are separate switches.
- The Catalyst 5000 series Switch 1 is the primary VMPS server.
- The Catalyst 5000 series Switch 3 and Switch 10 are secondary VMPS servers.
- End stations are connected to these clients:
 - Catalyst 2900 XL Switch 2
 - Catalyst 3500 XL Switch 9
- The database configuration file is called Bldg-G.db and is stored on the TFTP server with the IP address 172.20.22.7.

Figure 8-7 Dynamic Port VLAN Membership Configuration

