

Configuration Examples

This appendix contains configuration examples for the following ATM components:

- LEC
- LES
- RFC 1483
- MPOA

The LANE configuration example shows you the process of configuring LANE servers and clients. The RFC-1483 PVC configuration example shows you the process of configuring support for RFC 1483. The MPOA configuration example shows you the process of configuring MPOA servers and clients.

LANE Configuration Example

Figure C-1 shows a LANE configuration example with the following components:

- LightStream 1010 ATM switch
- Catalyst 2924M XL switch with an ATM module
- Catalyst 5000 series switch with an ATM module

Figure C-1 LANE Configuration Example

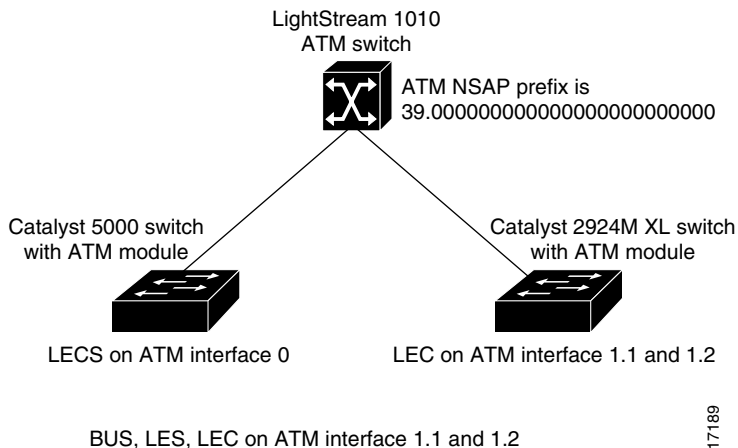

Configuration Example Assumptions

The following assumptions apply to the LANE configuration example in Figure C-1:

- The Enterprise Edition Software is running on the Catalyst 2924M XL switch.
- The LightStream 1010 ATM switch default ATM Network Service Access Point (NSAP) prefix is 39.00000000000000000000000000000000.
- The Catalyst 5000 switch has an ATM module installed in Slot 3.
- The Catalyst 5000 switch runs the LECS on ATM interface 0.
- The Catalyst 5000 switch runs the LEC BUS and LES on ATM interface 0.1 for the emulated LAN *default*.
- The Catalyst 5000 switch runs the LEC BUS and LES on ATM interface 0.2 for the emulated LAN *engineering*.
- The Catalyst 2924M XL switch has an ATM module installed in Slot 1.
- The Catalyst 2924M XL switch runs the LEC on ATM interface 1.1 for the emulated LAN *default*.

- The Catalyst 2924M XL switch runs the LEC on ATM interface 1.2 for the emulated LAN *engineering*.
- The VLAN trunk is turned on for Slot 1 of the Catalyst 2924M XL switch.

Configuration Example Procedure

To configure the LANE example in Figure C-1, follow these steps:

Step 1 Configure the LECS ATM NSAP address on the LightStream 1010 ATM switch:

- Start a session on the Catalyst 5000 ATM module by entering the **session 3** command at the Catalyst 5000 management console:

```
Console> session 3
Trying ATM-3...
Connected to ATM-3.
Escape character is '^]'.
ATM>
```

- Obtain the default LECS address from the Catalyst 5000 by entering the **enable** and **show lane default** commands:

```
ATM> enable
ATM# show lane default
interface ATM0:
LANE Client:          39.00000000000000000000000000000000.00605C28DA20.**
LANE Server:         39.00000000000000000000000000000000.00605C28DA21.**
LANE Bus:            39.00000000000000000000000000000000.00605C28DA22.**
LANE Config Server: 39.00000000000000000000000000000000.00605C28DA23.00
note: ** is the subinterface number byte in hex
ATM#
```

The default LECS address is
39.00000000000000000000000000000000.00605C28DA23.00.

LANE Configuration Example

- (c) Configure the LECS ATM NSAP address and its LECS sequence number on the LightStream1010 ATM switch. Use the default LECS address obtained from the Catalyst 5000 switch, and append the number 1 at the end of the address to specify the sequence number.
- (d) Enter the **enable**, **configure terminal**, and **atm lecs-address atm_address** commands at the LightStream 1010 management console:

```
Switch> enable
Switch# configure terminal
Enter configuration commands, one per line. End with CNTRL/Z.
Switch(config)# atm lecs-address
39.00000000000000000000000000000000.00605C28DA23.00 1
Switch(config)# ^Z
Switch#
```

The LightStream 1010 LECS ATM NSAP address is 39.00000000000000000000000000000000.00605C28DA23.00. The LECS address sequence number is 1; it is the first LECS on the LightStream 1010 ATM switch.

- (e) Save the configuration to NVRAM by entering the **write memory** command.

- Step 2** Configure the BUS and LES for the emulated LAN *default* on the Catalyst 5000 switch by entering the **configure terminal**, **interface atm0.1**, and **lane server-bus ethernet default** commands at the Catalyst 5000 switch management console:

```
ATM# configure terminal
Enter configuration commands, one per line. End with CNTL/Z.
ATM(config)# interface atm0.1
ATM(config-if)# lane server-bus ethernet default
ATM(config-if)# ^Z
ATM#
```

- Step 3** Configure the BUS and LES for the ELAN *engineering* on the Catalyst 5000 switch by entering the **interface atm0.2** and **lane server-bus ethernet engineering** commands at the Catalyst 5000 switch management console:

```
ATM(config)# interface atm0.2
ATM(config-if)# lane server-bus ethernet engineering
ATM(config-if)# ^Z
ATM#
```

- Step 4** Save the configuration to NVRAM by entering the **write memory** command.

- Step 5** Configure the LECS database on the Catalyst 5000 switch with the LANE server address obtained in Step 1. Replace the asterisks (******) with the subinterface number of the interface in which the LES and BUS is configured. In this example, that number is 01 for the ELAN named *default* and 02 for the ELAN named *engineering*.

Enter the **lane database** *database_name*, **name** *elan_name* **server-atm-address** *atm_address*, and the **default-name** *elan_name* commands:

```
ATM(config)# lane database test
ATM(lane-config-database)# name default server-atm-address
39.0000000000000000000000000000.00605C28DA21.01
ATM(lane-config-database)# default-name default
ATM(lane-config-database)# name engineering server-atm-address
39.0000000000000000000000000000.00605C28DA21.02
ATM(lane-config-database)# ^Z
ATM#
```

The LECS database is created with the following particulars:

- The LECS database name is *test*.
- The ELAN names are *default* and *engineering*.
- The LES ATM NSAP address is 39.0000000000000000000000000000.00605C28DA21.01 for the ELAN named *default*.
- The LES ATM NSAP address is 39.0000000000000000000000000000.00605C28DA21.02 for the ELAN named *engineering*.

LANE Configuration Example

Step 6 Save the configuration to NVRAM by entering the **write memory** command.

Step 7 Start and bind the LECS on the Catalyst 5000 switch by entering the **interface atm0**, the **lane config database_name**, and the **lane auto-config-atm-address** commands:

```
ATM# configure terminal
Enter configuration commands, one per line, End with CNTRL/Z.
ATM(config)# interface atm0
ATM(config-if)# lane config test
ATM(config-if)# lane auto-config-atm-address
ATM(config-if)# ^Z
ATM#
```

Step 8 Save the configuration to NVRAM by entering the **write memory** command.

Step 9 Start the LEC for the ELAN named *default* on the Catalyst 5000 switch by entering the **interface atm0.1** and the **lane client ethernet 1 default** commands:

```
ATM# configure terminal
Enter configuration commands, one per line. End with CNTL/Z.
ATM(config)# interface atm0.1
ATM(config-subif)# lane client ethernet 1 default
ATM(config-subif)# ^Z
ATM#
```

Step 10 Start the LEC for the ELAN named *engineering* on the Catalyst 5000 switch by entering the **interface atm0.2** and the **lane client ethernet 2 engineering** commands:

```
ATM# configure terminal
Enter configuration commands, one per line. End with CNTL/Z.
ATM(config)# interface atm0.2
ATM(config-subif)# lane client ethernet 2 engineering
ATM(config-subif)# ^Z
ATM#
```

Step 11 Save the configuration to NVRAM by entering the **write memory** command.

- Step 12** Start a session on the ATM module by entering the **session 1** command at the Catalyst 2924M XL management console:

```
switch# session 1

ATM> Entering Console for module in slot 1
Type  "^G" to end this session

Press RETURN to get started!

ATM>
```

- Step 13** Start the LEC for the ELAN named *default* on the Catalyst 2924M XL switch by entering the **interface atm1.1 multipoint** and the **lane client ethernet 1 default** commands at the Catalyst 2924M XL management console:

```
ATM# enable
ATM# configure terminal
Enter configuration commands, one per line.  End with CNTL/Z.
ATM(config)# interface atm1.1 multipoint
ATM(config-if)# lane client ethernet 1 default
ATM(config-if)# ^Z
ATM#
```

- Step 14** Start the LEC for the ELAN named *engineering* on the Catalyst 2924M XL switch by entering the **interface atm1.2 multipoint** and the **lane client ethernet 2 engineering** commands at the Catalyst 2924M XL management console:

```
ATM# configure terminal
Enter configuration commands, one per line.  End with CNTL/Z.
ATM(config)# interface atm1.2 multipoint
ATM(config-if)# lane client ethernet 2 engineering
ATM(config-if)# ^Z
ATM#
```

- Step 15** Save the configuration to NVRAM by entering the **write memory** command.

```
ATM# write memory
Building configuration ...
[OK]
ATM#
```

RFC-1483 PVC Configuration Example

Figure C-2 shows an example of an RFC-1483 PVC configuration with of the following components:

- LightStream 1010 ATM switch
- Catalyst 2924M XL switches with an ATM module
- Cisco router

Figure C-2 RFC-1483 PVC Configuration Example

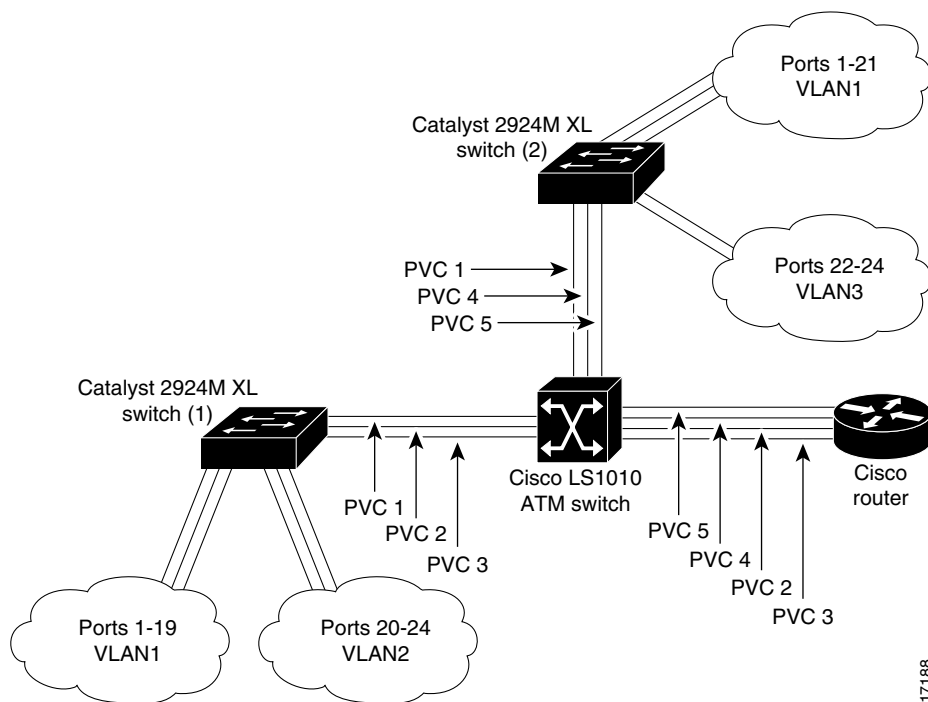

17188

Configuration Example Assumptions

The following assumptions apply to the RFC-1483 PVC configuration example in Figure C-2:

- The Enterprise Edition software is running on the Catalyst 2900 XL switches.
- The ATM modules are in Slot A.
- Ports on the Catalyst 2900 XL switches are in several VLANs.
- The VLAN domain name is *Cisco Engineering*.
- The Cisco router is configured with PVCs.
- The purpose of the Cisco router is to route packets between different VLANs.

The following specifications are required to connect the devices to the LS1010 ATM switch:

| LS1010 ATM Switch Interface | Connection |
|-----------------------------|------------------------------|
| atm0/0/0 | Catalyst 2924M XL switch (1) |
| atm0/0/1 | Catalyst 2924M XL switch (2) |
| atm0/0/2 | Cisco router |

The following specifications are assumed for the VLAN and switch connections:

| PVC | VLAN/Switch Connections | VCD | VPI | VLAN ID | VCI | Peak Rate (kbps) | Average Rate (kbps) | Burst Cell Rate |
|-----|--|-----|-----|---------|-----|------------------|---------------------|-----------------|
| 1 | Connects Catalyst 2924M XL switch (1) to Catalyst 2924M XL switch (2) on VLAN1 | 100 | 0 | 1 | 100 | default | default | default |
| 2 | Connects Catalyst 2924M XL switch (1) to Cisco router on VLAN1 | 101 | 0 | 1 | 101 | 50,000 | 50,000 | 32 |
| 3 | Connects Catalyst 2924M XL switch (1) to Cisco router on VLAN2 | 102 | 0 | 2 | 102 | 30,000 | 30,000 | 4 |

RFC-1483 PVC Configuration Example

| PVC | VLAN/Switch Connections | VCD | VPI | VLAN ID | VCI | Peak Rate (kbps) | Average Rate (kbps) | Burst Cell Rate |
|-----|--|-----|-----|---------|-----|------------------|---------------------|-----------------|
| 4 | Connects Catalyst 2924M XL switch (2) to Cisco router on VLAN3 | 103 | 0 | 3 | 103 | 30,000 | 10,000 | 32 |
| 5 | Connects Catalyst 2924M XL switch (2) to Cisco router on VLAN1 | 104 | 0 | 1 | 104 | 30,000 | 20,000 | default |

Configuration Example Procedure

To configure the RFC-1483 PVC example in Figure C-2, follow these steps:

- Step 1** Configure VLANs on the Catalyst 2924M XL switch (1).
- Step 2** Configure VLANs on the Catalyst 2924M XL switch (2).
- Step 3** Configure PVCs on the ATM Network.
- Step 4** Configure PVCs on Catalyst 2924M XL switch (1).
- Step 5** Configure PVCs on Catalyst 2924M XL switch (2).

Configure VLANs on the Catalyst 2924M XL Switch (1)

To configure VLANs on the Catalyst 2924M XL switch (1), use the Enterprise Edition Software to do the following:

- Step 1** Assign a management domain.
- Step 2** Define VLANs.
- Step 3** Group switch ports to VLANs.
- Step 4** Check the trunk mode.

Refer to the *Cisco IOS Desktop Switching Enterprise Edition Software Configuration Guide* for information about the following:

- Assigning a management domain
- Defining VLANs
- Grouping switch ports to VLANs

Checking the Trunk Mode

The ATM module automatically displays as a VLAN trunk. If the module does not display as a VLAN trunk when you use the **show interface atm1.1 switchport** command, check the following:

- Ensure that you are using the Enterprise Edition Software (IOS Release 11.2(8)SA5 or later). The standard edition software does not support the ATM module in trunk mode.
- Ensure that you are not attempting to run multi-VLANs and trunks simultaneously.

Configure VLANs on the Catalyst 2924M XL Switch (2)

When the Virtual Terminal Protocol (VTP) is enabled, the Catalyst 2924M XL switch (2) learns the VLAN configuration from Catalyst 2924M XL switch (1). It is not necessary to assign a management domain and define a VLAN. To configure VLANs on the Catalyst 2924M XL switch (1), do the following:

- Group switch ports to VLAN3.
- Check the trunk mode.

Refer to the *Cisco IOS Desktop Switching Enterprise Edition Software Configuration Guide* for information about grouping switch ports to VLANs. For information on trunk modes, see “Checking the Trunk Mode.”

Configure PVCs on the ATM Network

To configure PVCs on the ATM network, do the following on the LS1010 ATM switch:

- Step 1** Create PVC1 on the ATM network by entering the **enable** command and providing the information as shown in the following example.

```
Switch> enable
Password: <password>
Switch# configure terminal
Enter configuration commands, one per line. End with CNTL/Z.
Switch(config)# int atm0/0/0
Switch(config-if)# atm pvc 0 100 interface atm0/0/1 0 100
Switch(config-if)# ^Z
Switch#
```

- Step 2** Verify the setup of PVC 1 by entering the **show atm vc interface** command.

```
Switch# show atm vc interface atm0/0/0
```

The following display appears:

| Interface | VPI | VCI | Type | X-Interface | X-VPI | X-VCI | Encap | Status |
|-----------|-----|-----|------|-------------|-------|-------|-------|--------|
| ATM0/0/0 | 0 | 5 | PVC | ATM2/0/0 | 0 | 48 | QSAAL | UP |
| ATM0/0/0 | 0 | 16 | PVC | ATM2/0/0 | 0 | 32 | ILMI | UP |
| ATM0/0/0 | 0 | 100 | PVC | ATM0/0/1 | 0 | 100 | | UP |

- Step 3** Create PVC2 on the ATM network by entering the **enable** command and providing the information as shown in the following example.

```
Switch> enable
Password: <password>
Switch# configure terminal
Enter configuration commands, one per line. End with CNTL/Z.
Switch(config)# int atm0/0/0
Switch(config-if)# atm pvc 0 101 interface atm0/0/2 0 101
Switch(config-if)# ^Z
Switch#
```

Step 4 Verify the setup of PVC2 by entering the **show atm vc interface** command.

```
Switch# show atm vc interface atm0/0/0
```

The following display appears:

| Interface | VPI | VCI | Type | X-Interface | X-VPI | X-VCI | Encap | Status |
|-----------|-----|-----|------|-------------|-------|-------|-------|--------|
| ATM0/0/0 | 0 | 5 | PVC | ATM2/0/0 | 0 | 48 | QSAAL | UP |
| ATM0/0/0 | 0 | 16 | PVC | ATM2/0/0 | 0 | 32 | ILMI | UP |
| ATM0/0/0 | 0 | 100 | PVC | ATM0/0/1 | 0 | 100 | | UP |
| ATM0/0/0 | 0 | 101 | PVC | ATM0/0/2 | 0 | 101 | | UP |

Step 5 Create PVC3 on the ATM network by entering the **enable** command for the LS1010 ATM switch, and providing the information as shown in the following example.

```
Switch> enable
Password: <password>
Switch# configure terminal
Enter configuration commands, one per line. End with CNTL/Z.
Switch(config)# int atm0/0/0
Switch(config-if)# atm pvc 0 102 interface atm0/0/2 0 102
Switch(config-if)# ^Z
Switch#
```

Step 6 Verify the setup of PVC3 by entering the **show atm vc interface** command.

```
Switch# show atm vc interface atm0/0/0
```

The following display appears:

| Interface | VPI | VCI | Type | X-Interface | X-VPI | X-VCI | Encap | Status |
|-----------|-----|-----|------|-------------|-------|-------|-------|--------|
| ATM0/0/0 | 0 | 5 | PVC | ATM2/0/0 | 0 | 48 | QSAAL | UP |
| ATM0/0/0 | 0 | 16 | PVC | ATM2/0/0 | 0 | 32 | ILMI | UP |

RFC-1483 PVC Configuration Example

| Interface | VPI | VCI | Type | X-Interface | X-VPI | X-VCI | Encap | Status |
|-----------|-----|-----|------|-------------|-------|-------|-------|--------|
| ATM0/0/0 | 0 | 100 | PVC | ATM0/0/1 | 0 | 100 | | UP |
| ATM0/0/0 | 0 | 101 | PVC | ATM0/0/2 | 0 | 101 | | UP |
| ATM0/0/0 | 0 | 102 | PVC | ATM0/0/2 | 0 | 102 | | UP |

Step 7 Create PVC4 on the ATM network by entering the **enable** command and providing the information as shown in the following example.

```
Switch> enable
Password: <password>
Switch# configure terminal
Enter configuration commands, one per line. End with CNTL/Z.
Switch(config)# int atm0/0/1
Switch(config-if)# atm pvc 0 103 interface atm0/0/2 0 103
Switch(config-if)# ^Z
Switch#
```

Step 8 Verify the setup of PVC4 by entering the **show atm vc interface** command.

```
Switch# show atm vc interface atm0/0/1
```

The following display appears:

| Interface | VPI | VCI | Type | X-Interface | X-VPI | X-VCI | Encap | Status |
|-----------|-----|-----|------|-------------|-------|-------|-------|--------|
| ATM0/0/1 | 0 | 5 | PVC | ATM2/0/0 | 0 | 49 | QSAAL | UP |
| ATM0/0/1 | 0 | 16 | PVC | ATM2/0/0 | 0 | 33 | ILMI | UP |
| ATM0/0/1 | 0 | 100 | PVC | ATM0/0/0 | 0 | 100 | | UP |
| ATM0/0/1 | 0 | 103 | PVC | ATM0/0/2 | 0 | 103 | | UP |

- Step 9** Create PVC5 on the ATM network by entering the **enable** command and providing the information as shown in the following example.

```
Switch> enable
Password: <password>
Switch# configure terminal
Enter configuration commands, one per line. End with CNTL/Z.
Switch(config)# int atm0/0/1
Switch(config-if)# atm pvc 0 104 interface atm0/0/2 0 104
Switch(config-if)# ^Z
Switch#
```

- Step 10** Verify the setup of PVC5 by entering the **show atm vc interface** command.

```
Switch# show atm vc interface atm0/0/1
```

The following display appears:

| Interface | VPI | VCI | Type | X-Interface | X-VPI | X-VCI | Encap | Status |
|-----------|-----|-----|------|-------------|-------|-------|-------|--------|
| ATM0/0/0 | 0 | 5 | PVC | ATM2/0/0 | 0 | 50 | QSAAL | UP |
| ATM0/0/0 | 0 | 16 | PVC | ATM2/0/0 | 0 | 34 | ILMI | UP |
| ATM0/0/1 | 0 | 100 | PVC | ATM0/0/1 | 0 | 100 | | UP |
| ATM0/0/1 | 0 | 103 | PVC | ATM0/0/2 | 0 | 103 | | UP |
| ATM0/0/1 | 0 | 104 | PVC | ATM0/0/2 | 0 | 104 | | UP |

Configure Catalyst 2924M XL Switch (1)

To configure Catalyst 2924M XL switch (1), do the following:

- Step 1** Start a session on the ATM module by entering the **session 1** command at the Catalyst 2924M XL management console:

```
switch# session 1

ATM> Entering Console for module in slot 1
Type "^G" to end this session

Press RETURN to get started!

ATM>
```

- Step 2** Set up PVC1, PVC2 and PVC3 on the Catalyst 2924M XL switch (1) by entering the **enable** command and providing the information as shown in the following example.

```
ATM > enable
ATM# configure terminal
Enter configuration commands, one per line. End with CTRL/Z.
ATM(config)# interface atm1
ATM(config-if)# atm pvc 100 0 100 aa15snap
ATM(config-if)# atm pvc 101 0 101 aa15snap 50000 50000 32
ATM(config-if)# atm pvc 102 0 102 aa15snap 30000 30000 4
ATM(config-if)# ^Z
```

- Step 3** Bind PVC1 and PVC2 to VLAN1, and bind PVC3 to VLAN2 by entering the **configure terminal** command and providing the information as shown in the following example.

```
ATM# configure terminal
Enter configuration commands, one per line. End with CTRL/Z.
ATM(config)# interface atm1
ATM(config-if)# atm bind pvc vlan 100 1
ATM(config-if)# atm bind pvc vlan 101 1
ATM(config-if)# atm bind pvc vlan 102 2
```

- Step 4** Verify the setup on the Catalyst 2924M XL switch (1) by entering the **show atm vlan** command.

```
ATM# show atm vlan
```

The following display appears:

```
VCD                VLAN-ID
100                1
101                1
102                2
```

Step 5 Continue verifying the setup on the Catalyst 2924M XL switch (1) by entering the **show atm vc** command.

```
ATM# show atm vc
```

The following display appears:

| Interface | VCD | VPI | VCI | Type | AAL/ Encapsulation | Peak kbps | Avg. kbps | Burst Cells | Status |
|-----------|-----|-----|-----|------|-----------------------|--------------|--------------|----------------|--------|
| ATM1 | 1 | 0 | 5 | PVC | AAL5-SAAL | 155000 | 155000 | 4 | ACT |
| ATM1 | 2 | 0 | 16 | PVC | AAL5-ILMI | 155000 | 155000 | 4 | ACT |
| ATM1 | 100 | 0 | 100 | PVC | AAL5-SNAP | 155000 | 155000 | 4 | ACT |
| ATM1 | 101 | 0 | 101 | PVC | AAL5-SNAP | 50000 | 50000 | 32 | ACT |
| ATM1 | 102 | 0 | 102 | PVC | AAL5-SNAP | 30000 | 30000 | 4 | ACT |

Step 6 Write the configuration to Flash EPROM by entering the **write memory** command.

```
ATM# write memory
Building configuration ...
[OK]
ATM#
```

Configure PVCs on Catalyst 2924M XL Switch (2)

To configure PVCs on switch (2), do the following:

- Step 1** Start a session on the ATM module by entering the **session 1** command at the Catalyst 2924M XL management console:

```
switch# session 1

ATM> Entering Console for module in slot 1
Type "^G" to end this session

Press RETURN to get started!

ATM>
```

- Step 2** Set up PVC1, PVC4, and PVC 5 on the Catalyst 2924M XL switch (2) by entering the **enable** command and providing the information as shown in the following example.

```
ATM > enable
ATM# configure terminal
Enter configuration commands, one per line. End with CTRL/Z.
ATM(config)# interface atm1
ATM(config-if)# atm pvc 100 0 100 aa15snap
ATM(config-if)# atm pvc 103 0 103 aa15snap 30000 10000 32
ATM(config-if)# atm pvc 104 0 104 aa15snap 30000 20000
ATM(config-if)# ^Z
```

- Step 3** Bind PVC1 and 5 to VLAN1, and bind PVC 4 to VLAN3 by entering the **configure terminal** command and providing the information as shown in the following example.

```
ATM# configure terminal
Enter configuration commands, one per line. End with CTRL/Z.
ATM(config)# interface atm1
ATM(config-if)# atm bind pvc vlan 100 1
ATM(config-if)# atm bind pvc vlan 104 1
ATM(config-if)# atm bind pvc vlan 103 3
```

- Step 4** Verify the setup on the Catalyst 2924M XL switch (2) by entering the **show atm vlan** command.

```
ATM# show atm vlan
```

The following display appears:

```

VCD                VLAN-ID
-----
100                1
103                3
104                1
    
```

Step 5 Continue verifying the setup on the Catalyst 2924M XL switch (2) by entering the **show atm vc** command.

```
ATM# show atm vc
```

The following display appears:

| Interface | VCD | VPI | VCI | Type | AAL/ Encapsulation | Peak kbps | Avg. kbps | Burst Cells | Status |
|-----------|-----|-----|-----|------|-----------------------|--------------|--------------|----------------|--------|
| ATM1 | 1 | 0 | 5 | PVC | AAL5-SAAL | 155000 | 155000 | 4 | ACT |
| ATM1 | 2 | 0 | 16 | PVC | AAL5-ILMI | 155000 | 155000 | 4 | ACT |
| ATM1 | 100 | 0 | 100 | PVC | AAL5-SNAP | 155000 | 155000 | 4 | ACT |
| ATM1 | 103 | 0 | 103 | PVC | AAL5-SNAP | 30000 | 10000 | 32 | ACT |
| ATM1 | 104 | 0 | 104 | PVC | AAL5-SNAP | 30000 | 20000 | 4 | ACT |

Step 6 Write the configuration to Flash EPROM by entering the **write memory** command.

```

ATM# write memory
Building configuration ...
[OK]
ATM#
    
```

MPOA Configuration Example

Figure C-3 shows an MPOA configuration example with the following components:

- LightStream 1010 ATM switch
- Catalyst 2924M XL switch with an ATM module
- Cisco 7500 router with an ATM module

Figure C-3 MPOA Configuration Example

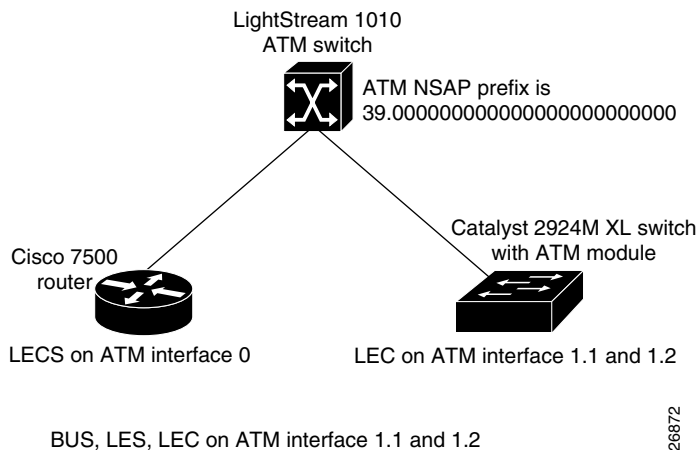

Configuration Example Assumptions

The following assumptions apply to the MPOA configuration example in Figure C-3:

- The Enterprise Edition Software is running on the Catalyst 2924M XL switch.
- The Catalyst 2924M XL switch is configured as an MPC.
- The LightStream 1010 ATM switch default ATM Network Service Access Point (NSAP) prefix is 39.000000000000000000000000.
- The Cisco 7500 router has an ATM module installed in Slot 1.
- The Cisco 7500 router runs the LECS on ATM interface 0.
- The Cisco 7500 router runs the LEC BUS and LES on ATM interface 0.1 for the emulated LAN *default*.
- This Cisco 7500 router is configured as an MPS.
- The Cisco 7500 router runs the LEC BUS and LES on ATM interface 0.2 for the emulated LAN *engineering*.
- The Catalyst 2924M XL switch has an ATM module installed in Slot 1.
- The Catalyst 2924M XL switch runs the LEC on ATM interface 1.1 for the emulated LAN *default*.
- The Catalyst 2924M XL switch runs the LEC on ATM interface 1.2 for the emulated LAN *engineering*.
- The VLAN trunk is turned on for Slot 1 of the Catalyst 2924M XL switch.

Configuration Example Procedure

To configure the MPOA example in Figure C-3, follow these steps:

Step 1 Configure LANE as explained in “LANE Configuration Example” section on page C-1.

Step 2 Configure the ELAN ID on the Cisco 7500 router using one of the following steps:

(a) Define an ELAN ID for the ELAN by entering the **name** command:

```
Router> enable
Router# configure terminal
Router(config)# lane database database name
Router(LANE)# name elan-name elan-id id
```

(b) Configure the LEC with the ELAN ID by entering the **lane server-bus ethernet** command:

```
Router> enable
Router# configure terminal
Router(config)# interface atm1/0/0.1
Router(config-if)# lane server-bus ethernet elan-name elan-id
id
Router(config-if)# ^Z
Router#
```

Step 3 Configure the Catalyst 2924 XL switch as an MPC:

(a) Specify an MPC name by entering the **mpoa client configure name** command.

```
Switch> enable
Switch# session 1
ATM> enable
ATM# configure terminal
ATM(config)# mpoa client configure name mpc-name
ATM(mpoa-client-config)# ^Z
ATM#
```

- (b) Attach an MPC to the ATM interface by entering the **mpoa client name** command:

```
Switch> enable
Switch# session 1
ATM> enable
ATM# configure terminal
ATM(config)# interface atm1
ATM(config-if)# mpoa client name mpc-name
ATM(config-if)# ^Z
ATM#
```

- (c) Specify the ATM interface that contains the LEC to which you will bind the MPC by entering the **interface** command:

```
Switch> enable
Switch# session 1
ATM> enable
ATM# configure terminal
ATM(config)# interface atm1
ATM(config-if)# interface atm-num.sub-interface-num mul
ATM(config-subif)# ^Z
ATM#
```

- (d) Bind a LANE client to the specified MPC by entering the **lane client mpoa** command:

```
Switch> enable
Switch# session 1
ATM> enable
ATM# configure terminal
ATM(config)# interface atm1.1
ATM(config-subif)# lane client mpoa client name mpc-name
ATM(config-subif)# ^Z
ATM#
```

- (e) Repeat substep (c) and (d) for every LEC to be served by the MPC and MPS.

Step 4 Configure the MPC variables:

- (a) Specify an MPC name by entering the **mpoa client configure name** command:

```
Switch> enable
Switch# session 1
ATM> enable
ATM# configure terminal
ATM(config)# mpoa client configure name mpc-name
ATM(mpoa-client-config)# ^Z
ATM#
```

- (b) (Optional) Specify the control ATM address that the MPC should use when it is associated with a hardware interface by entering the **atm-address** command:

```
Switch> enable
Switch# session 1
ATM> enable
ATM# configure terminal
ATM(config)# mpoa client config name mpc-name
ATM(mpoa-client-config)# atm-address atm-address
ATM(mpoa-client-config)# ^Z
ATM#
```

- (c) (Optional) Specify the maximum number of times a packet can be routed to the default router within shortcut-frame time before an MPOA resolution request is sent by entering the **shortcut-frame-count** command:

```
Switch> enable
Switch# session 1
ATM> enable
ATM# configure terminal
ATM(config)# mpoa client config name mpc-name
ATM(mpoa-client-config)# shortcut-frame-count count
ATM(mpoa-client-config)# ^Z
ATM#
```

- (d) (Optional) Set the shortcut-setup frame time for the MPC by entering the **shortcut-frame-time** command:

```
Switch> enable
Switch# session 1
ATM> enable
ATM# configure terminal
ATM(config)# mpoa client config name mpc-name
ATM(mpoa-client-config)# shortcut-frame-time time
ATM(mpoa-client-config)# ^Z
ATM#
```

Step 5 Configure the Cisco 7500 router as an MPS:

- (a) Specify an MPS name by entering the **mpoa server config name** command:

```
Router> enable
Router# configure terminal
Router(config)# mpoa server config name mps-name
Router(mpoa-server-config)# ^Z
Router#
```

- (b) Attach the MPS to the ATM interface by entering the **mpoa server name** command:

```
Router> enable
Router# configure terminal
Router(config)# interface atm1/0
Router(config-if)# mpoa server name mps-name
Router(config-if)# ^Z
Router#
```

- (c) Bind a LANE client to the specified MPS by entering the **lane client mpoa server name** command:

```
Router> enable
Router# configure terminal
Router(config)# interface atm1/0.1
Router(config-if)# lane client mpoa server name mps-name
Router(config-if)# ^Z
Router#
```

Step 6 Configure the MPS Variables:

- (a) Specify an MPS name by entering the **mpos server config name** command:

```
Router> enable
Router# configure terminal
Router(config)# mpoa server config name mps-name
Router(mpoa-server-config)# ^Z
Router#
```

- (b) (Optional) Specify the control ATM address that the MPS should use when it is associated with a hardware interface by entering the **atm-address** command:

```
Router> enable
Router# configure terminal
Router(config)# mpoa server config name mps-name
Router(mpoa-server-config)# atm-address atm-address
Router(mpoa-server-config)# ^Z
Router#
```

- (c) (Optional) Specify the network ID of the MPS by entering the **network-id** command:

```
Router> enable
Router# configure terminal
Router(config)# mpoa server config name mps-name
Router(mpoa-server-config)# network-id id
Router(mpoa-server-config)# ^Z
Router#
```

- (d) (Optional) Specify the keepalive time value for the MPS by entering the **keepalive-time** command:

```
Router> enable
Router# configure terminal
Router(config)# mpoa server config name mps-name
Router(mpoa-server-config)# keepalive-time time
Router(mpoa-server-config)# ^Z
Router#
```

- (e) (Optional) Specify the holding time value for the MPS by entering the **holding-time** command:

```
Router> enable
Router# configure terminal
Router(config)# mpoa server config name mps-name
Router(mpoa-server-config)# holding-time time
Router(mpoa-server-config)# ^Z
Router#
```

