

Configuring Layer 3 Interfaces

This chapter describes how to configure Layer 3 interfaces for Cisco NX-OS devices

This chapter includes the following sections:

- [Information About Layer 3 Interfaces, page 4-1](#)
- [Licensing Requirements for Layer 3 Interfaces, page 4-5](#)
- [Guidelines and Limitations, page 4-5](#)
- [Default Settings, page 4-6](#)
- [Prerequisites for Layer 3 Interfaces, page 4-5](#)
- [Configuring Layer 3 Interfaces, page 4-6](#)
- [Verifying the Layer 3 Interfaces Configuration, page 4-17](#)
- [Monitoring Layer 3 Interfaces, page 4-18](#)
- [Configuration Examples for Layer 3 Interfaces, page 4-19](#)
- [Related Topics, page 4-19](#)
- [Additional References, page 4-19](#)
- [Feature History for Configuring Layer 3 Interfaces, page 4-20](#)

Information About Layer 3 Interfaces

Layer 3 interfaces forward IPv4 and IPv6 packets to another device using static or dynamic routing protocols. You can use Layer 3 interfaces for IP routing and inter-VLAN routing of Layer 2 traffic.

You cannot configure a shared interface as a Layer 3 interface. See the *Cisco NX-OS FCoE Configuration Guide for Cisco Nexus 7000 and Cisco MDS 9500* for information on shared interfaces.

Beginning with Cisco Release 5.2(1), you can configure a Fabric Extender (FEX) port as a Layer 3 interface for host connectivity, but not for routing. See the *Configuring the Cisco Nexus 2000 Series Fabric Extender* for more information on fabric extenders.

This section includes the following topics:

- [Routed Interfaces, page 4-2](#)
- [Subinterfaces, page 4-2](#)
- [VLAN Interfaces, page 4-3](#)
- [Loopback Interfaces, page 4-4](#)

Send document comments to nexus7k-docfeedback@cisco.com

- [Tunnel Interfaces](#), page 4-4
- [High Availability](#), page 4-4
- [Virtualization Support](#), page 4-5

Routed Interfaces

You can configure a port as a Layer 2 interface or a Layer 3 interface. A routed interface is a physical port that can route IP traffic to another device. A routed interface is a Layer 3 interface only and does not support Layer 2 protocols, such as the Spanning Tree Protocol (STP).

All Ethernet ports are routed interfaces by default. You can change this default behavior with the CLI setup script or through the **system default switchport** command.

You can assign an IP address to the port, enable routing, and assign routing protocol characteristics to this routed interface.

Beginning with Cisco Release 4.2(1), you can assign a static MAC address to a Layer 3 interface. By default, the MAC address for the Layer 3 interfaces is the MAC address of the VDC it is assigned to. For information on configuring MAC addresses, see the *Cisco Nexus 7000 Series NX-OS Layer 2 Switching Configuration Guide, Release 5.x*.

You can also create a Layer 3 port channel from routed interfaces. For more information on port channels, see [Chapter 6, “Configuring Port Channels.”](#)

Routed interfaces and subinterfaces support exponentially decayed rate counters. Cisco NX-OS tracks the following statistics with these averaging counters:

- Input packets/sec
- Output packets/sec
- Input bytes/sec
- Output bytes/sec

Subinterfaces

You can create virtual subinterfaces on a parent interface configured as a Layer 3 interface. A parent interface can be a physical port or a port channel.

Subinterfaces divide the parent interface into two or more virtual interfaces on which you can assign unique Layer 3 parameters such as IP addresses and dynamic routing protocols. The IP address for each subinterface should be in a different subnet from any other subinterface on the parent interface.

You create a subinterface with a name that consists of the parent interface name (for example, Ethernet 2/1) followed by a period and then by a number that is unique for that subinterface. For example, you could create a subinterface for Ethernet interface 2/1 named Ethernet 2/1.1 where .1 indicates the subinterface.

Cisco NX-OS enables subinterfaces when the parent interface is enabled. You can shut down a subinterface independent of shutting down the parent interface. If you shut down the parent interface, Cisco NX-OS shuts down all associated subinterfaces as well.

One use of subinterfaces is to provide unique Layer 3 interfaces to each virtual local area network (VLAN) supported by the parent interface. In this scenario, the parent interface connects to a Layer 2 trunking port on another device. You configure a subinterface and associate the subinterface to a VLAN ID using 802.1Q trunking.

Send document comments to nexus7k-docfeedback@cisco.com

Figure 4-1 shows a trunking port from a switch that connects to router B on interface E 2/1. This interface contains three subinterfaces that are associated with each of the three VLANs carried by the trunking port.

Figure 4-1 Subinterfaces for VLANs

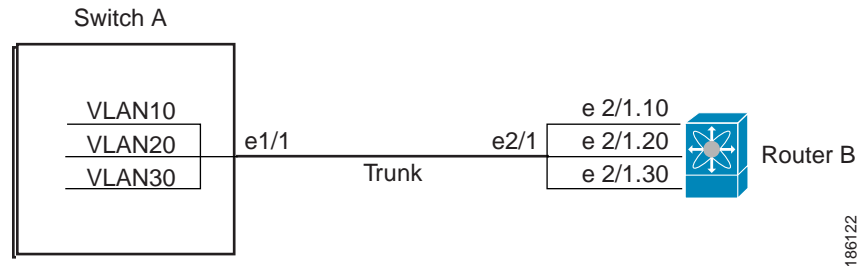

For more information on VLANs, see the *Cisco Nexus 7000 Series NX-OS Layer 2 Switching Configuration Guide, Release 5.x*.

VLAN Interfaces

A VLAN interface or switch virtual interfaces (SVI), is a virtual routed interface that connects a VLAN on the device to the Layer 3 router engine on the same device. Only one VLAN interface can be associated with a VLAN, but you need to configure a VLAN interface for a VLAN only when you want to route between VLANs or to provide IP host connectivity to the device through a virtual routing and forwarding (VRF) instance that is not the management VRF. When you enable VLAN interface creation, Cisco NX-OS creates a VLAN interface for the default VLAN (VLAN 1) to permit remote switch administration.

You must enable the VLAN network interface feature before you can see configure it. Beginning in Cisco NX-OS Release 4.2, the system automatically takes a checkpoint prior to disabling the feature, and you can rollback to this checkpoint. See *Cisco Nexus 7000 Series NX-OS System Management Configuration Guide, Release 5.x*, for information on rollbacks and checkpoints.

You must configure the VLAN network interface in the same VDC as the VLAN.



Note

You cannot delete the VLAN interface for VLAN 1.

You can route across VLAN interfaces to provide Layer 3 inter-VLAN routing by configuring a VLAN interface for each VLAN that you want to route traffic to and assigning an IP address on the VLAN interface. For more information on IP addresses and IP routing, see the *Cisco Nexus 7000 Series NX-OS Unicast Routing Configuration Guide, Release 5.x*.

Figure 4-2 shows two hosts connected to two VLANs on a device. You can configure VLAN interfaces for each VLAN that allows Host 1 to communicate with Host 2 using IP routing between the VLANs. VLAN 1 communicates at Layer 3 over VLAN interface 1 and VLAN 10 communicates at Layer 3 over VLAN interface 10.

Send document comments to nexus7k-docfeedback@cisco.com

Figure 4-2 Connecting Two VLANs with VLAN interfaces

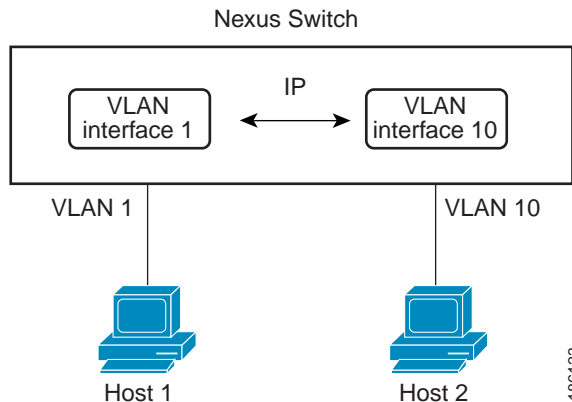

Note

You can configure VLAN interface for inband management in the Cisco Nexus 7000 Series switches with the F1 Series modules in the chassis.

Loopback Interfaces

A loopback interface is a virtual interface with a single endpoint that is always up. Any packet transmitted over a loopback interface is immediately received by this interface. Loopback interfaces emulate a physical interface. You can configure up to 1024 loopback interfaces per VDC, numbered 0 to 1023.

You can use loopback interfaces for performance analysis, testing, and local communications. Loopback interfaces can act as a termination address for routing protocol sessions. This loopback configuration allows routing protocol sessions to stay up even if some of the outbound interfaces are down.

Tunnel Interfaces

Cisco NX-OS supports tunnel interfaces as IP tunnels. IP tunnels can encapsulate a same-layer or higher layer protocol and transport the result over IP through a tunnel created between two routers. See [Chapter 8, “Configuring IP Tunnels,”](#) for more information on IP tunnels.

High Availability

Layer 3 interfaces support stateful and stateless restarts. After the switchover, Cisco NX-OS applies the runtime configuration after the switchover.

See the *Cisco Nexus 7000 Series NX-OS High Availability and Redundancy Guide, Release 5.x*, for complete information on high availability.

Send document comments to nexus7k-docfeedback@cisco.com

Virtualization Support

Layer 3 interfaces support Virtual Routing and Forwarding instances (VRFs). VRFs exist within virtual device contexts (VDCs). By default, Cisco NX-OS places you in the default VDC and default VRF unless you specifically configure another VDC and VRF. A Layer 3 logical interface (VLAN interface, loopback) configured in one VDC is isolated from a Layer 3 logical interface with the same number configured in another VDC. For example, loopback 0 in VDC 1 is independent of loopback 0 in VDC 2.

You can configure up to 1024 loopback interfaces per VDC.

You can associate the interface with a VRF. For VLAN interfaces, you must configure the VLAN interface in the same VDC as the VLAN.

See the *Cisco Nexus 7000 Series NX-OS Virtual Device Context Configuration Guide, Release 5.x*, for information about VDCs and see the *Cisco Nexus 7000 Series NX-OS Unicast Routing Configuration Guide, Release 5.x*, for information about configuring an interface in a VRF.



Note

You must assign an interface to a VRF before you configure the IP address for that interface.

Licensing Requirements for Layer 3 Interfaces

The following table shows the licensing requirements for this feature:

Product	License Requirement
Cisco NX-OS	Layer 3 interfaces require no license. Any feature not included in a license package is bundled with the Cisco NX-OS system images and is provided at no extra charge to you. For a complete explanation of the Cisco NX-OS licensing scheme, see the <i>Cisco NX-OS Licensing Guide</i> .

Prerequisites for Layer 3 Interfaces

Layer 3 interfaces have the following prerequisites:

- You have installed the Advanced Services license and entered the desired VDC (see the *Cisco Nexus 7000 Series NX-OS Virtual Device Context Configuration Guide, Release 5.x*, if you are configuring VDCs).
- You are familiar with IP addressing and basic configuration. See the *Cisco Nexus 7000 Series NX-OS Unicast Routing Configuration Guide, Release 5.x*, for more information on IP addressing.

Guidelines and Limitations

Layer 3 interfaces have the following configuration guidelines and limitations:

- If you change a Layer 3 interface to a Layer 2 interface, Cisco NX-OS shuts down the interface, reenables the interface, and removes all configuration specific to Layer 3.
- If you change a Layer 2 interface to a Layer 3 interface, Cisco NX-OS shuts down the interface, reenables the interface, and deletes all configuration specific to Layer 2.

Send document comments to nexus7k-docfeedback@cisco.com

- The Cisco Nexus 2000 Fabric Extender can not participate in a routing protocol adjacency with a device attached to its port. Only direct route is supported. This applies to both of the supported connectivity cases:
 - SVI with Fabric Extender single port or port-channel in Layer 2 mode.
 - Fabric Extender port or port-channel in Layer 3 mode.
- Layer 3 router interfaces and sub-interfaces can not be configured on an F1 I/O module.
- F2-series I/O modules do not support per-VLAN statistics. Therefore, the `show interface` command will not display per-VLAN Rx/Tx counters or statistics for switch virtual interfaces (SVIs).



Note

If you are familiar with the Cisco IOS CLI, be aware that the Cisco NX-OS commands for this feature might differ from the Cisco IOS commands that you would use.

Default Settings

Table 4-1 lists the default settings for Layer 3 interface parameters.

Table 4-1 Default Layer 3 Interface Parameters

Parameters	Default
Admin state	Shut

Configuring Layer 3 Interfaces

This section includes the following topics:

- [Configuring a Routed Interface, page 4-6](#)
- [Configuring a Subinterface, page 4-8](#)
- [Configuring the Bandwidth on an Interface, page 4-10](#)
- [Configuring a VLAN interface, page 4-10](#)
- [Configuring Inband Management in the Nexus Chassis, page 4-13](#)
- [Configuring a Loopback Interface, page 4-15](#)
- [Assigning an Interface to a VRF, page 4-16](#)

Configuring a Routed Interface

You can configure any Ethernet port as a routed interface.

BEFORE YOU BEGIN

Ensure that you are in the correct VDC (or use the `switchto vdc` command).

Send document comments to nexus7k-docfeedback@cisco.com

SUMMARY STEPS

1. **configure terminal**
2. **interface ethernet *slot/port***
3. **no switchport**
4. **ip address *ip-address/length***
or
ipv6 address *ipv6-address/length*
5. **(Optional) show interfaces**
6. **(Optional) copy running-config startup-config**

DETAILED STEPS

	Command	Purpose
Step 1	configure terminal Example: switch# configure terminal switch(config)#	Enters configuration mode.
Step 2	interface ethernet <i>slot/port</i> Example: switch(config)# interface ethernet 2/1 switch(config-if)#	Enters interface configuration mode.
Step 3	no switchport Example: switch(config-if)# no switchport	Configures the interface as a Layer 3 interface and deletes any configuration specific to Layer 2 on this interface.
Step 4	ip address <i>ip-address/length</i> Example: switch(config-if)# ip address 192.0.2.1/8 ipv6 address <i>ipv6-address/length</i> Example: switch(config-if)# ipv6 address 2001:0DB8::1/8	Configures an IP address for this interface. See the <i>Cisco Nexus 7000 Series NX-OS Unicast Routing Configuration Guide, Release 5.x</i> , for more information on IP addresses. Configures an IPv6 address for this interface. See the <i>Cisco Nexus 7000 Series NX-OS Unicast Routing Configuration Guide, Release 5.x</i> , for more information on IPv6 addresses.
Step 5	show interfaces Example: switch(config-if)# show interfaces ethernet 2/1	(Optional) Displays the Layer 3 interface statistics.
Step 6	copy running-config startup-config Example: switch(config)# copy running-config startup-config	(Optional) Saves this configuration change.

Use the **medium** command to set the interface medium to either point to point or broadcast.

Send document comments to nexus7k-docfeedback@cisco.com

Command	Purpose
<code>medium {broadcast p2p}</code> Example: <code>switch(config-if)# medium p2p</code>	Configures the interface medium as either point to point or broadcast.



Note

The default setting is **broadcast**, and this setting does not appear in any of the **show** commands. However, if you do change the setting to **p2p**, you will see this setting when you enter the **show running config** command.

Use the **switchport** command to convert a Layer 3 interface into a Layer 2 interface.

Command	Purpose
<code>switchport</code> Example: <code>switch(config-if)# switchport</code>	Configures the interface as a Layer 2 interface and deletes any configuration specific to Layer 3 on this interface.

This example shows how to configure a routed interface:

```
switch# configure terminal
switch(config)# interface ethernet 2/1
switch(config-if)# no switchport
switch(config-if)# ip address 192.0.2.1/8
switch(config-if)# copy running-config startup-config
```

The default setting for interfaces is routed. If you want to configure an interface for Layer 2, enter the **switchport** command. Then, if you change a Layer 2 interface to a routed interface, enter the **no switchport** command.

Configuring a Subinterface

You can configure one or more subinterfaces on a routed interface or on a port channel made from routed interfaces.

BEFORE YOU BEGIN

Configure the parent interface as a routed interface.

See the [“Configuring a Routed Interface”](#) section on page 4-6.

Create the port-channel interface if you want to create a subinterface on that port channel.

Ensure that you are in the correct VDC (or use the **switchto vdc** command).

SUMMARY STEPS

1. **configure terminal**
2. **interface ethernet** *slot/port.number*

Send document comments to nexus7k-docfeedback@cisco.com

3. **ip address** *ip-address/length*
or
ipv6 address *ipv6-address/length*
4. **encapsulation dot1q** *vlan-id*
5. **(Optional) show interfaces**
6. **(Optional) copy running-config startup-config**

DETAILED STEPS

	Command	Purpose
Step 1	configure terminal Example: switch# configure terminal switch(config)#	Enters configuration mode.
Step 2	interface ethernet <i>slot/port.number</i> Example: switch(config)# interface ethernet 2/1.1 switch(config-subif)#	Creates a subinterface and enters subinterface configuration mode. The <i>number</i> range is from 1 to 4094.
Step 3	ip address <i>ip-address/length</i> Example: switch(config-subif)# ip address 192.0.2.1/8	Configures an IP address for this subinterface. See the <i>Cisco Nexus 7000 Series NX-OS Unicast Routing Configuration Guide, Release 5.x</i> , for more information on IP addresses.
	ipv6 address <i>ipv6-address/length</i> Example: switch(config-subif)# ipv6 address 2001:0DB8::1/8	
Step 4	encapsulation dot1q <i>vlan-id</i> Example: switch(config-subif)# encapsulation dot1q 33	Configures IEEE 802.1Q VLAN encapsulation on the subinterface. The range is from 2 to 4093.
Step 5	show interfaces Example: switch(config-subif)# show interfaces ethernet 2/1.1	(Optional) Displays the Layer 3 interface statistics.
Step 6	copy running-config startup-config Example: switch(config-subif)# copy running-config startup-config	(Optional) Saves this configuration change.

This example shows how to create a subinterface:

```
switch# configure terminal
switch(config)# interface ethernet 2/1.1
switch(config-if)# ip address 192.0.2.1/8
switch(config-if)# encapsulation dot1q 33
switch(config-if)# copy running-config startup-config
```

Send document comments to nexus7k-docfeedback@cisisco.com

Configuring the Bandwidth on an Interface

You can configure the bandwidth for a routed interface, port channel, or subinterface. Higher layer protocols use bandwidth parameter to calculate path costs. You can configure the bandwidth on a subinterface with one of the following methods:

- **Explicit**—Set the bandwidth value for the subinterface directly.
- **Inherit**—Set the bandwidth that all subinterfaces inherit from the parent interface as either a specific value or as the bandwidth of the parent interface.

If you do not set the subinterface bandwidth or configure it to inherit the bandwidth from the parent interface, Cisco NX-OS determines the subinterface bandwidth as follows:

- If the parent interface is up, then the bandwidth of the subinterface is the same as the operational speed of the parent interface. For ports, the subinterface bandwidth is the configured or negotiated link speed. For port channels, the subinterface bandwidth is the aggregate of the link speeds of individual members of the port channel.
- If the parent interface is down, then the bandwidth of the subinterface depends on the type of parent interface:
 - Port-channel subinterfaces have 100-Mb/s bandwidth for subinterfaces.
 - 1-Gb/s Ethernet ports have 1-Gb/s bandwidth for subinterfaces.
 - 10-Gb/s Ethernet ports have 10-Gb/s bandwidth for subinterfaces.

To configure the bandwidth of an interface, use the following command in interface mode:

Command	Purpose
bandwidth Example: switch(config-if)# bandwidth 100000	Configures the bandwidth parameter for a routed interface, port channel, or subinterface.

To configure subinterfaces to inherit the bandwidth from the parent interface, use the following command in interface mode:

Command	Purpose
bandwidth inherit [value] Example: switch(config-if)# bandwidth inherit 100000	Configures all subinterfaces of this interface to inherit the bandwidth value configured. If you do not configure the value, the subinterfaces inherit the bandwidth of the parent interface. The range is from 1 to 10000000, in kilobytes.

Configuring a VLAN interface

You can create VLAN interfaces to provide inter-VLAN routing.

BEFORE YOU BEGIN

Ensure that you are in the correct VDC (or use the **switchto vdc** command).

Send document comments to nexus7k-docfeedback@cisco.com

SUMMARY STEPS

1. **configure terminal**
2. **feature interface-vlan**
3. **interface vlan *number***
4. **ip address *ip-address/length***
or
ipv6 address *ipv6-address/length*
5. **(Optional) show interface vlan *number***
6. **(Optional) copy running-config startup-config**

DETAILED STEPS

	Command	Purpose
Step 1	configure terminal Example: switch# configure terminal switch(config)#	Enters configuration mode.
Step 2	feature interface-vlan Example: switch(config)# feature interface-vlan	Enables VLAN interface mode.
Step 3	interface vlan <i>number</i> Example: switch(config)# interface vlan 10 switch(config-if)#	Creates a VLAN interface. The <i>number</i> range is from 1 to 4094.
Step 4	ip address <i>ip-address/length</i> Example: switch(config-if)# ip address 192.0.2.1/8 ipv6 address <i>ipv6-address/length</i> Example: switch(config-if)# ipv6 address 2001:0DB8::1/8	Configures an IP address for this VLAN interface. See the <i>Cisco Nexus 7000 Series NX-OS Unicast Routing Configuration Guide, Release 5.x</i> , for more information on IP addresses.
Step 5	show interface vlan <i>number</i> Example: switch(config-if)# show interface vlan 10	(Optional) Displays the Layer 3 interface statistics.
Step 6	copy running-config startup-config Example: switch(config-if)# copy running-config startup-config	(Optional) Saves this configuration change.

Send document comments to nexus7k-docfeedback@cisco.com

This example shows how to create a VLAN interface:

```
switch# configure terminal
switch(config)# feature interface-vlan
switch(config)# interface vlan 10
switch(config-if)# ip address 192.0.2.1/8
switch(config-if)# copy running-config startup-config
```

Send document comments to nexus7k-docfeedback@cisco.com

Configuring Inband Management in the Nexus Chassis

You can create a VLAN interface for inband management in the Cisco Nexus 7000 Series switches when there are only F1 Series modules in the chassis.

**Caution**

We recommend that you use a dedicated VLAN for inband management on the F1 Series modules. Do not run data traffic on the VLAN that you are using for inband management.

BEFORE YOU BEGIN

Ensure that you are in the correct VDC (or use the **switchto vdc** command).

SUMMARY STEPS

1. **configure terminal**
2. **feature interface-vlan**
3. **interface vlan** *number*
4. **no shutdown**
5. **management**
6. **ip address** *ip-address/length*
7. **(Optional) show interface vlan** *number*
8. **(Optional) copy running-config startup-config**

Send document comments to nexus7k-docfeedback@cisco.com

DETAILED STEPS

	Command	Purpose
Step 1	<code>configure terminal</code> Example: <code>switch# configure terminal</code> <code>switch(config)#</code>	Enters configuration mode.
Step 2	<code>feature interface-vlan</code> Example: <code>switch(config)# feature interface-vlan</code>	Creates a loopback interface. The range is from 0 to 1023.
Step 3	<code>interface vlan number</code> Example: <code>switch(config)# interface vlan 10</code> <code>switch(config-if)#</code>	Creates a VLAN interface. The <i>number</i> range is from 1 to 4094. Note Configure the VLAN and add the interfaces.
Step 4	<code>no shutdown</code> Example: <code>switch(config-if)# no shutdown</code>	Brings an interface administratively up (enable/disable an interface).
Step 5	<code>management</code> Example: <code>switch(config-if)# management</code>	Allows in-band management access to a VLAN interface IP address.
Step 6	<code>ip address ip-address/length</code> Example: <code>switch(config-if)# ip address</code> <code>192.0.2.1/8</code>	Configures an IP address for this VLAN interface. See the <i>Cisco Nexus 7000 Series NX-OS Unicast Routing Configuration Guide, Release 5.x</i> , for more information on IP addresses.
Step 7	<code>show interface vlan number</code> Example: <code>switch(config-if)# show interface vlan</code> <code>10</code>	(Optional) Displays the Layer 3 interface statistics.
Step 8	<code>copy running-config startup-config</code> Example: <code>switch(config-if)# copy running-config</code> <code>startup-config</code>	(Optional) Saves this configuration change.

This example shows how to create an inband management in the Cisco Nexus 7000 chassis:

```
switch# configure terminal
switch(config)# feature interface-vlan
switch(config)# interface vlan 5
switch(config)# no shutdown
switch(config)# management
switch(config-if)# ip address 192.0.2.1/8
switch(config-if)# copy running-config startup-config
```

Send document comments to nexus7k-docfeedback@cisco.com

Configuring a Loopback Interface

You can configure a loopback interface to create a virtual interface that is always up.

BEFORE YOU BEGIN

Ensure that the IP address of the loopback interface is unique across all routers on the network.

Ensure that you are in the correct VDC (or use the **switchto vdc** command).

SUMMARY STEPS

1. **configure terminal**
2. **interface loopback** *instance*
3. **ipv4 address** *ip-address*
or
ipv6 address *ip-address*
4. **(Optional) show interfaces loopback** *instance*
5. **(Optional) copy running-config startup-config**

DETAILED STEPS

	Command	Purpose
Step 1	configure terminal Example: switch# configure terminal switch(config)#	Enters configuration mode.
Step 2	interface loopback <i>instance</i> Example: switch(config)# interface loopback 0 switch(config-if)#	Creates a loopback interface. The range is from 0 to 1023.
Step 3	ip address <i>ip-address/length</i> Example: switch(config-if)# ip address 192.0.2.100/8	Configures an IP address for this interface. See the <i>Cisco Nexus 7000 Series NX-OS Unicast Routing Configuration Guide, Release 5.x</i> , for more information on IP addresses.
	ipv6 address <i>ipv6-address/length</i> Example: switch(config-if)# ipv6 address 2001:0DB8::18/8	
Step 4	show interfaces loopback <i>instance</i> Example: switch(config-if)# show interfaces loopback 0	(Optional) Displays the loopback interface statistics.
Step 5	copy running-config startup-config Example: switch(config-if)# copy running-config startup-config	(Optional) Saves this configuration change.

Send document comments to nexus7k-docfeedback@cisisco.com

This example shows how to create a loopback interface:

```
switch# configure terminal
switch(config)# interface loopback 0
switch(config-if)# ip address 192.0.2.100/8
switch(config-if)# copy running-config startup-config
```

Assigning an Interface to a VRF

You can add a Layer 3 interface to a VRF.

BEFORE YOU BEGIN

Ensure that you are in the correct VDC (or use the **switchto vdc** command).

Assign the IP address for a tunnel interface after you have configured the interface for a VRF.

SUMMARY STEPS

1. **configure terminal**
2. **interface** *interface-type number*
3. **vrf member** *vrf-name*
4. **ip-address** *ip-prefix/length*
5. (Optional) **show vrf** [*vrf-name*] **interface** *interface-type number*
6. (Optional) **copy running-config startup-config**

DETAILED STEPS

	Command	Purpose
Step 1	configure terminal Example: switch# configure terminal switch(config)#	Enters configuration mode.
Step 2	interface <i>interface-type number</i> Example: switch(config)# interface loopback 0 switch(config-if)#	Enters interface configuration mode.
Step 3	vrf member <i>vrf-name</i> Example: switch(config-if)# vrf member RemoteOfficeVRF	Adds this interface to a VRF.
Step 4	ip address <i>ip-prefix/length</i> Example: switch(config-if)# ip address 192.0.2.1/16	Configures an IP address for this interface. You must do this step after you assign this interface to a VRF.

Send document comments to nexus7k-docfeedback@cisco.com

	Command	Purpose
Step 5	<pre>show vrf [vrf-name] interface interface-type number</pre> <p>Example: switch(config-vrf)# show vrf Enterprise interface loopback 0</p>	(Optional) Displays VRF information.
Step 6	<pre>copy running-config startup-config</pre> <p>Example: switch(config)# copy running-config startup-config</p>	(Optional) Saves this configuration change.

This example shows how to add a Layer 3 interface to the VRF:

```
switch# configure terminal
switch(config)# interface loopback 0
switch(config-if)# vrf member RemoteOfficeVRF
switch(config-if)# ip address 209.0.2.1/16
switch(config-if)# copy running-config startup-config
```

Verifying the Layer 3 Interfaces Configuration

To display the Layer 3 configuration, perform one of the following tasks:

Command	Purpose
show interface ethernet <i>slot/port</i>	Displays the Layer 3 interface configuration, status, and counters (including the 5-minute exponentially decayed moving average of inbound and outbound packet and byte rates).
show interface ethernet <i>slot/port</i> brief	Displays the Layer 3 interface operational status.
show interface ethernet <i>slot/port</i> capabilities	Displays the Layer 3 interface capabilities, including port type, speed, and duplex.
show interface ethernet <i>slot/port</i> description	Displays the Layer 3 interface description.
show interface ethernet <i>slot/port</i> status	Displays the Layer 3 interface administrative status, port mode, speed, and duplex.
show interface ethernet <i>slot/port.number</i>	Displays the subinterface configuration, status, and counters (including the f-minute exponentially decayed moving average of inbound and outbound packet and byte rates).
show interface port-channel <i>channel-id.number</i>	Displays the port-channel subinterface configuration, status, and counters (including the 5-minute exponentially decayed moving average of inbound and outbound packet and byte rates).
show interface loopback <i>number</i>	Displays the loopback interface configuration, status, and counters.
show interface loopback <i>number</i> brief	Displays the loopback interface operational status.

Send document comments to nexus7k-docfeedback@cisco.com

Command	Purpose
show interface loopback <i>number</i> description	Displays the loopback interface description.
show interface loopback <i>number</i> status	Displays the loopback interface administrative status and protocol status.
show interface vlan <i>number</i>	Displays the VLAN interface configuration, status, and counters.
show interface vlan <i>number</i> brief	Displays the VLAN interface operational status.
show interface vlan <i>number</i> description	Displays the VLAN interface description.
show interface vlan <i>number</i> private-vlan mapping	Displays the VLAN interface private VLAN information.
show interface vlan <i>number</i> status	Displays the VLAN interface administrative status and protocol status.

Monitoring Layer 3 Interfaces

Use the following commands to display Layer 3 statistics:

Command	Purpose
load- interval { interval <i>seconds</i> { 1 2 3 }}	Beginning with Cisco NX-OS Release 4.2(1) for the Cisco Nexus 7000 Series devices, sets three different sampling intervals to bit-rate and packet-rate statistics. The range for VLAN network interface is 60 to 300 seconds, and the range for Layer interfaces is 30 to 300 seconds.
show interface ethernet <i>slot/port</i> counters	Displays the Layer 3 interface statistics (unicast, multicast, and broadcast).
show interface ethernet <i>slot/port</i> counters brief	Displays the Layer 3 interface input and output counters.
show interface ethernet <i>slot/port</i> counters detailed [all]	Displays the Layer 3 interface statistics. You can optionally include all 32-bit and 64-bit packet and byte counters (including errors).
show interface ethernet <i>slot/port</i> counters errors	Displays the Layer 3 interface input and output errors.
show interface ethernet <i>slot/port</i> counters snmp	Displays the Layer 3 interface counters reported by SNMP MIBs. You cannot clear these counters.
show interface ethernet <i>slot/port.number</i> counters	Displays the subinterface statistics (unicast, multicast, and broadcast).
show interface port-channel <i>channel-id.number</i> counters	Displays the port-channel subinterface statistics (unicast, multicast, and broadcast).
show interface loopback <i>number</i> counters	Displays the loopback interface input and output counters (unicast, multicast, and broadcast).

Send document comments to nexus7k-docfeedback@cisco.com

Command	Purpose
show interface loopback <i>number</i> counters detailed [all]	Displays the loopback interface statistics. You can optionally include all 32-bit and 64-bit packet and byte counters (including errors).
show interface loopback <i>number</i> counters errors	Displays the loopback interface input and output errors.
show interface vlan <i>number</i> counters	Displays the VLAN interface input and output counters (unicast, multicast, and broadcast).
show interface vlan <i>number</i> counters detailed [all]	Displays the VLAN interface statistics. You can optionally include all Layer 3 packet and byte counters (unicast and multicast).
show interface vlan <i>number</i> counters snmp	Displays the VLAN interface counters reported by SNMP MIBs. You cannot clear these counters.

See the *Cisco Nexus 7000 Series NX-OS Interfaces Command Reference, Release 5.x*, for information on these commands.

Configuration Examples for Layer 3 Interfaces

This example shows how to configure Ethernet subinterfaces:

```
interface ethernet 2/1.10
    description Layer 3 for VLAN 10
    encapsulation dot1q 10
    ip address 192.0.2.1/8
```

This example shows how to configure a VLAN interface:

```
interface vlan 100
    ipv6 address 33:0DB::2/8
```

This example shows how to configure a loopback interface:

```
interface loopback 3
    ip address 192.0.2.2/32
```

Related Topics

The following topics can give more information on Layer 3 interfaces:

- [Chapter 6, “Configuring Port Channels”](#)
- *Cisco Nexus 7000 Series NX-OS Unicast Routing Configuration Guide, Release 5.x*

Additional References

For additional information related to implementing Layer 3 interfaces, see the following sections:

- [Related Documents, page 4-20](#)

Send document comments to nexus7k-docfeedback@cisco.com

- [MIBs](#), page 4-20
- [Standards](#), page 4-20

Related Documents

Related Topic	Document Title
command syntax	<i>Cisco Nexus 7000 Series NX-OS Interfaces Command Reference, Release 5.x</i>
IP	“Configuring IP” chapter in the <i>Cisco Nexus 7000 Series NX-OS Unicast Routing Configuration Guide, Release 5.x</i>
VLANs	“Configuring VLANs” chapter in the <i>Cisco Nexus 7000 Series NX-OS Layer 2 Switching Configuration Guide, Release 5.x</i>

MIBs

MIBs	MIBs Link
<ul style="list-style-type: none"> • IF-MIB • CISCO-IF-EXTENSION-MIB • ETHERLIKE-MIB 	To locate and download MIBs, go to the following URL: http://www.cisco.com/public/sw-center/netmgmt/cmtk/mibs.shtml

Standards

Standards	Title
No new or modified standards are supported by this feature, and support for existing standards has not been modified by this feature.	—

Feature History for Configuring Layer 3 Interfaces

Table 4-2 lists the release history for this feature.

Table 4-2 Feature History for Configuring Layer 3 Interfaces

Feature Name	Releases	Feature Information
Three configurable sampling intervals for interface statistics	4.2(1)	Added the load-interval command.
Layer 3 interfaces	4.0(1)	This feature was introduced.