



## CHAPTER 7

# Configuring 802.1X

---

This chapter describes how to configure IEEE 802.1X port-based authentication on NX-OS devices.

This chapter includes the following sections:

- [Information About 802.1X, page 7-1](#)
- [Licensing Requirements for 802.1X, page 7-7](#)
- [Prerequisites for 802.1X, page 7-8](#)
- [802.1X Guidelines and Limitations, page 7-8](#)
- [Configuring 802.1X, page 7-8](#)
- [Verifying the 802.1X Configuration, page 7-34](#)
- [Displaying 802.1X Statistics, page 7-34](#)
- [802.1X Example Configurations, page 7-35](#)
- [Default Settings, page 7-35](#)
- [Additional References, page 7-36](#)

## Information About 802.1X

802.1X defines a client-server-based access control and authentication protocol that restricts unauthorized clients from connecting to a LAN through publicly accessible ports. The authentication server authenticates each client connected to an NX-OS device port.

Until the client is authenticated, 802.1X access control allows only Extensible Authentication Protocol over LAN (EAPOL) traffic through the port to which the client is connected. After authentication is successful, normal traffic can pass through the port.

This section includes the following topics about 802.1X port-based authentication:

- [Device Roles, page 7-2](#)
- [Authentication Initiation and Message Exchange, page 7-3](#)
- [Ports in Authorized and Unauthorized States, page 7-4](#)
- [MAC Address Authentication Bypass, page 7-5](#)
- [802.1X with Port Security, page 7-6](#)
- [Supported Topologies, page 7-7](#)
- [Virtualization Support, page 7-7](#)

**Send document comments to [nexus7k-docfeedback@cisco.com](mailto:nexus7k-docfeedback@cisco.com)**

## Device Roles

With 802.1X port-based authentication, the devices in the network have specific roles as shown in Figure 7-1.

**Figure 7-1 802.1X Device Roles**

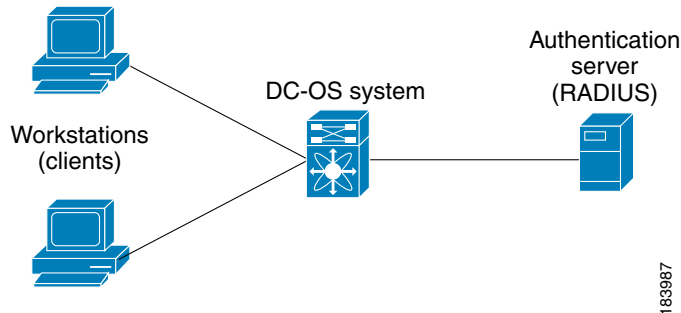

The specific roles shown in Figure 7-1 are as follows:

- **Supplicant**—The client device that requests access to the LAN and NX-OS device services and responds to requests from the NX-OS device. The workstation must be running 802.1X-compliant client software such as that offered in the Microsoft Windows XP operating device.



**Note** To resolve Windows XP network connectivity and 802.1X port-based authentication issues, read the Microsoft Knowledge Base article at this URL:  
<http://support.microsoft.com/support/kb/articles/Q303/5/97.ASP>

- **Authentication server**—The authentication server performs the actual authentication of the supplicant. The authentication server validates the identity of the supplicant and notifies the NX-OS device regarding whether the supplicant is authorized to access the LAN and NX-OS device services. Because the NX-OS device acts as the proxy, the authentication service is transparent to the supplicant. The Remote Authentication Dial-In User Service (RADIUS) security device with Extensible Authentication Protocol (EAP) extensions is the only supported authentication server; it is available in Cisco Secure Access Control Server, version 3.0. RADIUS uses a supplicant-server model in which secure authentication information is exchanged between the RADIUS server and one or more RADIUS clients.
- **Authenticator**—The authenticator controls the physical access to the network based on the authentication status of the supplicant. The authenticator acts as an intermediary (proxy) between the supplicant and the authentication server, requesting identity information from the supplicant, verifying the requested identity information with the authentication server, and relaying a response to the supplicant. The authenticator includes the RADIUS client, which is responsible for encapsulating and decapsulating the EAP frames and interacting with the authentication server.

When the authenticator receives EAPOL frames and relays them to the authentication server, the authenticator strips off the Ethernet header and encapsulates the remaining EAP frame in the RADIUS format. This encapsulation process does not modify or examine the EAP frames, and the authentication server must support EAP within the native frame format. When the authenticator receives frames from the authentication server, the authenticator removes the server's frame header, leaving the EAP frame, which the authenticator then encapsulates for Ethernet and sends to the supplicant.

***Send document comments to [nexus7k-docfeedback@cisco.com](mailto:nexus7k-docfeedback@cisco.com)***

**Note**

The NX-OS device can only be a 802.1X authenticator.

## Authentication Initiation and Message Exchange

Either the authenticator (NX-OS device) or the supplicant (client) can initiate authentication. If you enable authentication on a port, the authenticator must initiate authentication when it determines that the port link state transitions from down to up. The authenticator then sends an EAP-request/identity frame to the supplicant to request its identity (typically, the authenticator sends an initial identity/request frame followed by one or more requests for authentication information). When the supplicant receives the frame, it responds with an EAP-response/identity frame.

If the supplicant does not receive an EAP-request/identity frame from the authenticator during bootup, the supplicant can initiate authentication by sending an EAPOL-start frame, which prompts the authenticator to request the supplicant's identity.

**Note**

If 802.1X is not enabled or supported on the network access device, the NX-OS device drops any EAPOL frames from the supplicant. If the supplicant does not receive an EAP-request/identity frame after three attempts to start authentication, the supplicant transmits data as if the port is in the authorized state. A port in the authorized state means that the supplicant has been successfully authenticated. For more information, see the [“Ports in Authorized and Unauthorized States” section on page 7-4](#).

When the supplicant supplies its identity, the authenticator begins its role as the intermediary, passing EAP frames between the supplicant and the authentication server until authentication succeeds or fails. If the authentication succeeds, the authenticator port becomes authorized. For more information, see the [“Ports in Authorized and Unauthorized States” section on page 7-4](#).

The specific exchange of EAP frames depends on the authentication method being used. [Figure 7-2](#) shows a message exchange initiated by the supplicant using the One-Time-Password (OTP) authentication method with a RADIUS server. OTP authentication device uses a secret pass-phrase to generate a sequence of one-time (single use) passwords. The user's secret pass-phrase never crosses the network at any time such as during authentication or during pass-phrase changes.

**Send document comments to [nexus7k-docfeedback@cisco.com](mailto:nexus7k-docfeedback@cisco.com)**

**Figure 7-2 Message Exchange**

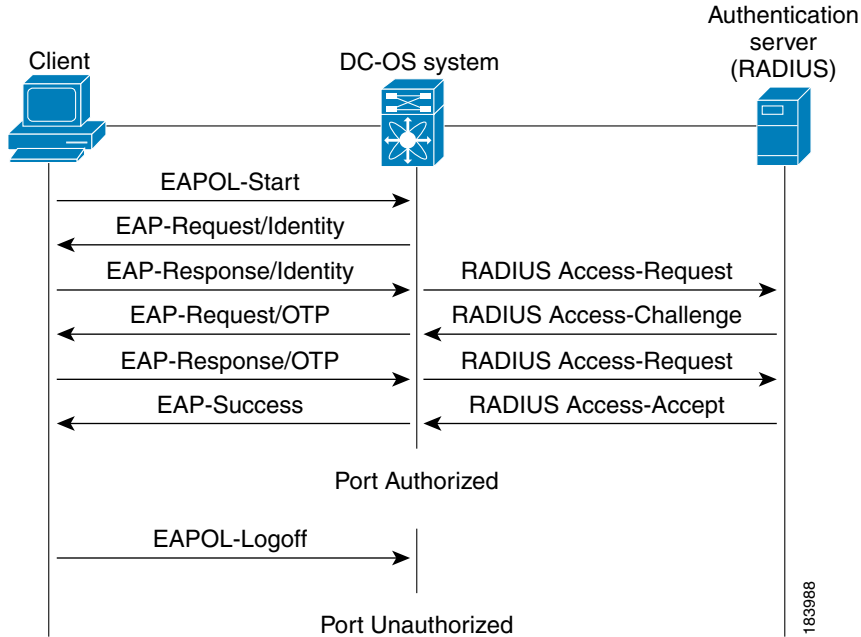

## Ports in Authorized and Unauthorized States

The authenticator port state determines if the supplicant is granted access to the network. The port starts in the unauthorized state. In this state, the port disallows all ingress and egress traffic except for 802.1X protocol packets. When a supplicant is successfully authenticated, the port transitions to the authorized state, allowing all traffic for the supplicant to flow normally.

If a client that does not support 802.1X is connected to an unauthorized 802.1X port, the authenticator requests the client's identity. In this situation, the client does not respond to the request, the port remains in the unauthorized state, and the client is not granted access to the network.

In contrast, when an 802.1X-enabled client connects to a port that is not running the 802.1X protocol, the client initiates the authentication process by sending the EAPOL-start frame. When no response is received, the client sends the request for a fixed number of times. Because no response is received, the client begins sending frames as if the port is in the authorized state.

Ports can have the following authorization states:

- **Force authorized**—Disables 802.1X port-based authentication and transitions to the authorized state without requiring any authentication exchange. The port transmits and receives normal traffic without 802.1X-based authentication of the client. This authorization state is the default.
- **Force unauthorized**—Causes the port to remain in the unauthorized state, ignoring all attempts by the client to authenticate. The authenticator cannot provide authentication services to the client through the interface.
- **Auto**—Enables 802.1X port-based authentication and causes the port to begin in the unauthorized state, allowing only EAPOL frames to be sent and received through the port. The authentication process begins when the link state of the port transitions from down to up or when an EAPOL-start frame is received from the supplicant. The authenticator requests the identity of the client and begins

***Send document comments to [nexus7k-docfeedback@cisco.com](mailto:nexus7k-docfeedback@cisco.com)***

relaying authentication messages between the client and the authentication server. Each supplicant that attempts to access the network is uniquely identified by the authenticator by using the supplicant's MAC address.

If the supplicant is successfully authenticated (receives an Accept frame from the authentication server), the port state changes to authorized, and all frames from the authenticated supplicant are allowed through the port. If the authentication fails, the port remains in the unauthorized state, but authentication can be retried. If the authentication server cannot be reached, the authenticator can retransmit the request. If no response is received from the server after the specified number of attempts, authentication fails, and the supplicant is not granted network access.

When a supplicant logs off, it sends an EAPOL-logoff message, which causes the authenticator port to transition to the unauthorized state.

If the link state of a port transitions from up to down, or if an EAPOL-logoff frame is received, the port returns to the unauthorized state.

## MAC Address Authentication Bypass

You can configure the NX-OS device to authorize a supplicant based on the supplicant MAC address by using the MAC authentication bypass feature. For example, you can enable this feature on interfaces configured for 802.1X that are connected to devices such as printers.

If 802.1X authentication times out while waiting for an EAPOL response from the supplicant, the NX-OS device tries to authorize the client by using MAC authentication bypass.

When you enable the MAC authentication bypass feature on an interface, the NX-OS device uses the MAC address as the supplicant identity. The authentication server has a database of supplicant MAC addresses that are allowed network access. After detecting a client on the interface, the NX-OS device waits for an Ethernet packet from the client. The NX-OS device sends the authentication server a RADIUS-access/request frame with a username and password based on the MAC address. If authorization succeeds, the NX-OS device grants the client access to the network. If authorization fails, the NX-OS device assigns the port to the guest VLAN if one is configured.

If an EAPOL packet is detected on the interface during the lifetime of the link, the NX-OS device determines that the device connected to that interface is an 802.1X-capable supplicant and uses 802.1X authentication (not MAC authentication bypass) to authorize the interface. EAPOL history is cleared if the interface link status goes down.

If the NX-OS device already authorized an interface by using MAC authentication bypass and detects an 802.1X supplicant, the NX-OS device does not unauthorize the client connected to the interface. When reauthentication occurs, the NX-OS device uses 802.1X authentication as the preferred reauthentication process if the previous session ended because the Termination-Action RADIUS attribute value is DEFAULT.

Clients that were authorized with MAC authentication bypass can be reauthenticated. The reauthentication process is the same as that for clients that were authenticated with 802.1X. During reauthentication, the port remains in the previously assigned VLAN. If reauthentication is successful, the switch keeps the port in the same VLAN. If reauthentication fails, the switch assigns the port to the guest VLAN, if one is configured.

If reauthentication is based on the Session-Timeout RADIUS attribute (Attribute[27]) and the Termination-Action RADIUS attribute (Attribute [29]) and if the Termination-Action RADIUS attribute (Attribute [29]) action is Initialize, (the attribute value is DEFAULT), the MAC authentication bypass session ends, and connectivity is lost during reauthentication. If MAC authentication bypass is enabled

## ***Send document comments to [nexus7k-docfeedback@cisco.com](mailto:nexus7k-docfeedback@cisco.com)***

and the 802.1X authentication times out, the switch uses the MAC authentication bypass feature to initiate reauthorization. For more information about these AV pairs, see RFC 3580, “IEEE 802.1X Remote Authentication Dial In User Service (RADIUS) Usage Guidelines.”

MAC authentication bypass interacts with the features:

802.1X authentication—You can enable MAC authentication bypass only if 802.1X authentication is enabled on the port.

Port security—See the “[802.1X with Port Security](#)” section on page 7-6.

Network admission control (NAC) Layer 2 IP validation—This feature takes effect after an 802.1X port is authenticated with MAC authentication bypass, including hosts in the exception list.

## **Single Host and Multiple Hosts Support**

The 802.1X feature can restrict traffic on a port to only one endpoint device (single-host mode) or allow traffic from multiple endpoint devices on a port (multi-host mode).

Single-host mode allows traffic from only one endpoint device on the 802.1X port. Once the endpoint device is authenticated, the NX-OS device puts the port in the authorized state. When the endpoint device leaves the port, the NX-OS device put the port back into the unauthorized state. A security violation in 802.1X is defined as a detection of frames sourced from any MAC address other than the single MAC address authorized as a result of successful authentication. In this case, the interface on which this security association violation is detected (EAPOL frame from the other MAC address) will be disabled. Single host mode is applicable only for host-to-switch topology and when a single host is connected to the Layer 2 (Ethernet access port) or Layer 3 port (routed port) of the NX-OS device.

Only the first host has to be authenticated on the 802.1X port configured with multiple host mode. The port is moved to the authorized state after the successful authorization of the first host. Subsequent hosts are not required to be authorized to gain network access once the port is in the authorized state. If the port becomes unauthorized when reauthentication fails or an EAPOL logoff message is received, all attached hosts are denied access to the network. The capability of the interface to shutdown upon security association violation is disabled in multiple host mode. This mode is applicable for both switch-to-switch and host-to-switch topologies.

## **802.1X with Port Security**

On NX-OS devices, you can configure 802.1X authentication and port security on the same Layer 2 ports. 802.1X uses RADIUS servers to authenticate the endpoint devices connected to a port. Port security secures ports based on MAC addresses, up to a maximum number of MAC addresses on a port. This difference allows the two features to work together. The NX-OS software supports 802.1X authentication with port security for Layer 2 ports in both host-to-switch and switch-to-switch topologies.

When 802.1X works with port security, both 802.1X and port security must authenticate supplicant MAC addresses. In multi-host mode, port security authenticates only the first supplicant MAC address. After the successful authentication of the first supplicant, the NX-OS device sends subsequent traffic from other supplicants to port security.

For more information on port security, see [Chapter 13, “Configuring Port Security.”](#)

***Send document comments to [nexus7k-docfeedback@cisco.com](mailto:nexus7k-docfeedback@cisco.com)***

## Supported Topologies

The 802.1X port-based authentication is supported in two topologies:

- Point-to-point
- Wireless LAN

In a point-to-point configuration (see [Figure 7-1 on page 7-2](#)), only one supplicant (client) can connect to the 802.1X-enabled authenticator (NX-OS device) port. The authenticator detects the supplicant when the port link state changes to the up state. If a supplicant leaves or is replaced with another supplicant, the authenticator changes the port link state to down, and the port returns to the unauthorized state.

[Figure 7-3](#) shows 802.1X port-based authentication in a wireless LAN. The 802.1X port is configured as a multiple-host port that becomes authorized as soon as one supplicant is authenticated. When the port is authorized, all other hosts indirectly attached to the port are granted access to the network. If the port becomes unauthorized (reauthentication fails or an EAPOL-logoff message is received), the NX-OS device denies access to the network to all of the attached supplicants.

**Figure 7-3 Wireless LAN Example**

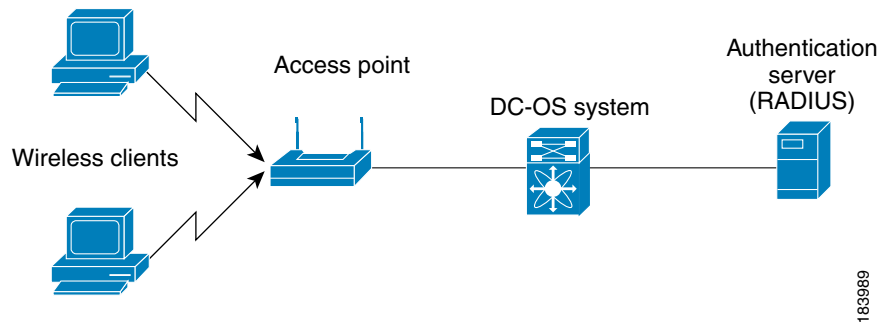

## Virtualization Support

802.1X configuration and operation are local to the virtual device context (VDC). For more information on VDCs, see the [Cisco Nexus 7000 Series NX-OS Virtual Device Context Configuration Guide, Release 4.0](#).

## Licensing Requirements for 802.1X

The following table shows the licensing requirements for this feature:

Product	License Requirement
NX-OS	802.1X requires no license. Any feature not included in a license package is bundled with the Cisco NX-OS system images and is provided at no extra charge to you. For a complete explanation of the NX-OS licensing scheme, see the <a href="#">Cisco Nexus 7000 Series NX-OS Licensing Guide, Release 4.0</a> .

*Send document comments to [nexus7k-docfeedback@cisco.com](mailto:nexus7k-docfeedback@cisco.com)*

## Prerequisites for 802.1X

802.1X has the following prerequisites:

- One or more RADIUS servers accessible in the network.
- 802.1X supplicants are attached to the ports, unless you enable MAC address authentication bypass (see the [“Enabling MAC Address Authentication Bypass”](#) section on page 7-23).

## 802.1X Guidelines and Limitations

802.1X port-based authentication has the following configuration guidelines and limitations:

- The NX-OS software supports 802.1X only on physical ports.
- The NX-OS software does not support 802.1X on subinterfaces or port channels.
- When you enable 802.1X authentication, supplicants are authenticated before any other Layer 2 or Layer 3 features are enabled on an Ethernet interface.
- The NX-OS software supports 802.1X authentication only on Ethernet interfaces that are in a port channel or a trunk.
- The NX-OS software does not support single host mode on trunk interfaces or member interfaces in a port channel.
- The NX-OS software does not support MAC address authentication bypass on trunk interfaces.
- The NX-OS software does not support the following 802.1X protocol enhancements:
  - One-to-many logical VLAN name to ID mapping
  - Web authorization
  - Dynamic domain bridge assignment
  - IP telephony
  - Guest VLANs

## Configuring 802.1X

This section includes the following topics:

- [Process for Configuring 802.1X, page 7-9](#)
- [Enabling the 802.1X Feature, page 7-10](#)
- [Configuring AAA Authentication Methods for 802.1X, page 7-11](#)
- [Controlling 802.1X Authentication on an Interface, page 7-12](#)
- [Enabling Global Periodic Reauthentication, page 7-13](#)
- [Enabling Periodic Reauthentication for an Interface, page 7-15](#)
- [Manually Reauthenticating Supplicants, page 7-16](#)
- [Manually Initializing 802.1X Authentication, page 7-17](#)
- [Changing Global 802.1X Authentication Timers, page 7-18](#)
- [Changing 802.1X Authentication Timers for an Interface, page 7-19](#)

## ***Send document comments to [nexus7k-docfeedback@cisco.com](mailto:nexus7k-docfeedback@cisco.com)***

- [Enabling Single Host or Multiple Hosts Mode, page 7-22](#)
- [Enabling MAC Address Authentication Bypass, page 7-23](#)
- [Disabling 802.1X Authentication on the NX-OS Device, page 7-24](#)
- [Disabling the 802.1X Feature, page 7-25](#)
- [Resetting the 802.1X Global Configuration to the Default Values, page 7-26](#)
- [Resetting the 802.1X Interface Configuration to the Default Values, page 7-27](#)
- [Setting the Global Maximum Authenticator-to-Supplicant Frame Retransmission Retry Count, page 7-28](#)
- [Configuring the Maximum Authenticator-to-Supplicant Frame Retransmission Retry Count for an Interface, page 7-29](#)
- [Enabling RADIUS Accounting for 802.1X Authentication, page 7-30](#)
- [Configuring AAA Accounting Methods for 802.1X, page 7-31](#)
- [Setting the Maximum Reauthentication Retry Count on an Interface, page 7-32](#)

**Note**

If you are familiar with the Cisco IOS CLI, be aware that the Cisco NX-OS commands for this feature might differ from the Cisco IOS commands that you would use.

## **Process for Configuring 802.1X**

Follow these steps to configure 802.1X authentication:

- 
- Step 1** Enable the 802.1X feature (see the [“Enabling the 802.1X Feature”](#) section on page 7-10).
  - Step 2** Configure the connection to the remote RADIUS server (see the [“Configuring AAA Authentication Methods for 802.1X”](#) section on page 7-11).
  - Step 3** Enable 802.1X authentication on the Ethernet interfaces (see the [“Controlling 802.1X Authentication on an Interface”](#) section on page 7-12).
- 

You can perform the following optional maintenance tasks for 802.1X authentication:

- [Enable periodic automatic reauthentication \(see the “Enabling Global Periodic Reauthentication” section on page 7-13\)](#)
- [Perform manual reauthentication \(see the “Manually Reauthenticating Supplicants” section on page 7-16\)](#)
- [Initialize the state of the 802.1X feature \(see the “Manually Initializing 802.1X Authentication” section on page 7-17\)](#)
- [Change the global 802.1X authentication timers \(see the “Changing Global 802.1X Authentication Timers” section on page 7-18\)](#)
- [Change the interface 802.1X authentication timers \(see the “Changing 802.1X Authentication Timers for an Interface” section on page 7-19\)](#)
- [Enable multiple hosts on an interface \(see the “Enabling Single Host or Multiple Hosts Mode” section on page 7-22\)](#)

## *Send document comments to [nexus7k-docfeedback@cisco.com](mailto:nexus7k-docfeedback@cisco.com)*

- Enable MAC address authentication bypass on an interface (see the “[Enabling MAC Address Authentication Bypass](#)” section on page 7-23)
- Disallow 802.1X authentication (see the “[Disabling 802.1X Authentication on the NX-OS Device](#)” section on page 7-24)
- Disable the 802.1X feature (see the “[Disabling the 802.1X Feature](#)” section on page 7-25)
- Reset the global 802.1X configuration to default values (see the “[Resetting the 802.1X Global Configuration to the Default Values](#)” section on page 7-26)
- Reset the interface 802.1X configuration to default values (see the “[Resetting the 802.1X Interface Configuration to the Default Values](#)” section on page 7-27)
- Change the frame retransmission retry count (see the “[Setting the Global Maximum Authenticator-to-Supplicant Frame Retransmission Retry Count](#)” section on page 7-28)
- Enable RADIUS accounting for 802.1X authentication (see the “[Enabling RADIUS Accounting for 802.1X Authentication](#)” section on page 7-30)
- Configure AAA accounting for 802.1X (see the “[Configuring AAA Accounting Methods for 802.1X](#)” section on page 7-31)
- Change the maximum 802.1X authentication requests (see the “[Configuring the Maximum Authenticator-to-Supplicant Frame Retransmission Retry Count for an Interface](#)” section on page 7-29)
- Change the maximum 802.1X reauthentication requests (see the “[Setting the Maximum Reauthentication Retry Count on an Interface](#)” section on page 7-32)

## Enabling the 802.1X Feature

You must enable the 802.1X feature on the NX-OS device before authenticating any supplicant devices.

### BEFORE YOU BEGIN

Ensure that you are in the correct VDC (or use the **switchto vdc** command).

### SUMMARY STEPS

1. **config t**
2. **feature dot1x**
3. **exit**
4. **show dot1x**
5. **copy running-config startup-config**

***Send document comments to [nexus7k-docfeedback@cisco.com](mailto:nexus7k-docfeedback@cisco.com)***

## DETAILED STEPS

	Command	Purpose
Step 1	<code>config t</code>  <b>Example:</b> switch# config t switch(config)#	Enters global configuration mode.
Step 2	<code>feature dot1x</code>  <b>Example:</b> switch(config)# feature dot1x	Enables the 802.1X feature. The default is disabled.
Step 3	<code>exit</code>  <b>Example:</b> switch(config)# exit switch#	Exits configuration mode.
Step 4	<code>show dot1x</code>  <b>Example:</b> switch# show dot1x	(Optional) Displays the 802.1X feature status.
Step 5	<code>copy running-config startup-config</code>  <b>Example:</b> switch# copy running-config startup-config	(Optional) Copies the running configuration to the startup configuration.

## Configuring AAA Authentication Methods for 802.1X

You can use remote RADIUS servers for 802.1X authentication. You must configure RADIUS servers and RADIUS server groups and specify the default AAA authentication method before the NX-OS device can perform 802.1X authentication.

For more information on configuring RADIUS servers, see [Chapter 3, “Configuring RADIUS.”](#) For information on configuring RADIUS server groups, see [Chapter 2, “Configuring AAA.”](#)

### BEFORE YOU BEGIN

Ensure that you are in the correct VDC (or use the `switchto vdc` command).

Obtain the names or addresses for the remote RADIUS server groups.

### SUMMARY STEPS

1. `config t`
2. `aaa authentication dot1x default group group-list`
3. `exit`
4. `show radius-server`
5. `show radius-server group [group-name]`
6. `copy running-config startup-config`

**Send document comments to [nexus7k-docfeedback@cisco.com](mailto:nexus7k-docfeedback@cisco.com)**

## DETAILED STEPS

	Command	Purpose
Step 1	<b>config t</b>  <b>Example:</b> switch# config t switch(config)#	Enters global configuration mode.
Step 2	<b>aaa authentication dot1x default group group-list</b>  <b>Example:</b> switch(config)# aaa authentication dot1x default group rad2	Specifies the RADIUS server groups to use for 802.1X authentication.  The <i>group-list</i> argument consists of a space-delimited list of group names. The group names are the following: <ul style="list-style-type: none"> <li>• <b>radius</b>—Uses the global pool of RADIUS servers for authentication.</li> <li>• <b>named-group</b>—Uses a named subset of RADIUS servers for authentication.</li> </ul>
Step 3	<b>exit</b>  <b>Example:</b> switch(config)# exit switch#	Exits configuration mode.
Step 4	<b>show radius-server</b>  <b>Example:</b> switch# show radius-server	(Optional) Displays the RADIUS server configuration.
Step 5	<b>show radius-server group [group-name]</b>  <b>Example:</b> switch# show radius-server group rad2	(Optional) Displays the RADIUS server group configuration.
Step 6	<b>copy running-config startup-config</b>  <b>Example:</b> switch# copy running-config startup-config	(Optional) Copies the running configuration to the startup configuration.

## Controlling 802.1X Authentication on an Interface

You can control the 802.1X authentication performed on an interface. An interface can have the following 802.1X authentication states:

- **Auto**—Enables 802.1X authentication on the interface.
- **Force-authorized**—Disables 802.1X authentication on the interface and allows all traffic on the interface without authentication. This state is the default.
- **Force-unauthorized**—Disallows all traffic on the interface.

## BEFORE YOU BEGIN

Ensure that you are in the correct VDC (or use the **switchto vdc** command).

Enable the 802.1X feature on the NX-OS device (see the [“Enabling the 802.1X Feature”](#) section on page 7-10).

***Send document comments to [nexus7k-docfeedback@cisco.com](mailto:nexus7k-docfeedback@cisco.com)***

## SUMMARY STEPS

1. `config t`
2. `interface ethernet slot/port`
3. `dot1x port-control {auto | forced-authorized | forced-unauthorized}`
4. `exit`
5. `show dot1x all`
6. `show dot1x interface ethernet slot/port`
7. `copy running-config startup-config`

## DETAILED STEPS

	Command	Purpose
Step 1	<code>config t</code>  <b>Example:</b> switch# config t switch(config)#	Enters global configuration mode.
Step 2	<code>interface ethernet <i>slot/port</i></code>  <b>Example:</b> switch(config)# interface ethernet 2/1 switch(config-if)#	Selects the interface to configure and enters interface configuration mode.
Step 3	<code>dot1x port-control {auto   force-authorized   forced-unauthorized}</code>  <b>Example:</b> switch(config-if)# dot1x port-control auto	Changes the 802.1X authentication state on the interface. The default is <b>force-authorized</b> .
Step 4	<code>exit</code>  <b>Example:</b> switch(config)# exit switch#	Exits configuration mode.
Step 5	<code>show dot1x all</code>  <b>Example:</b> switch# show dot1x all	(Optional) Displays all 802.1X feature status and configuration information.
Step 6	<code>show dot1x interface ethernet <i>slot/port</i></code>  <b>Example:</b> switch# show dot1x interface ethernet 2/1	(Optional) Displays 802.1X feature status and configuration information for an interface.
Step 7	<code>copy running-config startup-config</code>  <b>Example:</b> switch# copy running-config startup-config	(Optional) Copies the running configuration to the startup configuration.

## Enabling Global Periodic Reauthentication

You can enable global periodic 802.1X reauthentication and specify how often it occurs. If you do not specify a time period before enabling reauthentication, the number of seconds between reauthentication attempts is 3600 (1 hour).

## Send document comments to [nexus7k-docfeedback@cisco.com](mailto:nexus7k-docfeedback@cisco.com)

To manually reauthenticate supplicants, see the “Manually Reauthenticating Supplicants” section on page 7-16.



### Note

During the reauthentication process, the status of an already authenticated supplicant is not disrupted.

## BEFORE YOU BEGIN

Ensure that you are in the correct VDC (or use the `switchto vdc` command).

Enable the 802.1X feature on the NX-OS device (see the “Enabling the 802.1X Feature” section on page 7-10).

## SUMMARY STEPS

1. `config t`
2. `dot1x re-authentication`
3. `dot1x timeout re-authperiod seconds`
4. `exit`
5. `show dot1x all`
6. `copy running-config startup-config`

## DETAILED STEPS

	Command	Purpose
Step 1	<pre>config t</pre> <p><b>Example:</b>  <pre>switch# config t switch(config)#</pre></p>	Enters global configuration mode.
Step 2	<pre>dot1x re-authentication</pre> <p><b>Example:</b>  <pre>switch(config)# dot1x re-authentication</pre></p>	Enables periodic reauthentication for all supplicants on the NX-OS device. By default, periodic authentication is disabled.
Step 3	<pre>dot1x timeout re-authperiod seconds</pre> <p><b>Example:</b>  <pre>switch(config)# dot1x timeout re-authperiod 3000</pre></p>	<p>Sets the number of seconds between reauthentication attempts.</p> <p>The default is 3600 seconds. The range is from 1 to 65535.</p> <p><b>Note</b> This command affects the behavior of the NX-OS device only if you enable periodic reauthentication.</p>
Step 4	<pre>exit</pre> <p><b>Example:</b>  <pre>switch(config)# exit switch#</pre></p>	(Optional) Exits configuration mode.

**Send document comments to [nexus7k-docfeedback@cisco.com](mailto:nexus7k-docfeedback@cisco.com)**

	Command	Purpose
Step 5	<b>show dot1x all</b>  <b>Example:</b> switch# show dot1x	(Optional) Displays all 802.1X feature status and configuration information.
Step 6	<b>copy running-config startup-config</b>  <b>Example:</b> switch# copy running-config startup-config	(Optional) Copies the running configuration to the startup configuration.

## Enabling Periodic Reauthentication for an Interface

You can enable periodic 802.1X reauthentication on an interface and specify how often it occurs. If you do not specify a time period before enabling reauthentication, the number of seconds between reauthentication defaults to the global value.

To manually reauthenticate supplicants, see the [“Manually Reauthenticating Supplicants”](#) section on page 7-16.



### Note

During the reauthentication process, the status of an already authenticated supplicant is not disrupted.

### BEFORE YOU BEGIN

Ensure that you are in the correct VDC (or use the **switchto vdc** command).

Enable the 802.1X feature on the NX-OS device (see the [“Enabling the 802.1X Feature”](#) section on page 7-10).

### SUMMARY STEPS

1. **config t**
2. **interface ethernet *slot/port***
3. **dot1x re-authentication**
4. **dot1x timeout re-authperiod *seconds***
5. **exit**
6. **show dot1x all**
7. **copy running-config startup-config**

**Send document comments to [nexus7k-docfeedback@cisco.com](mailto:nexus7k-docfeedback@cisco.com)**

## DETAILED STEPS

	Command	Purpose
Step 1	<b>config t</b>  <b>Example:</b> switch# config t switch(config)#	Enters global configuration mode.
Step 2	<b>interface ethernet slot/port</b>  <b>Example:</b> switch(config)# interface ethernet 2/1 switch(config-if)#	(Optional) Selects the interface to configure and enters interface configuration mode.
Step 3	<b>dot1x re-authentication</b>  <b>Example:</b> switch(config-if)# dot1x re-authentication	(Optional) Enables periodic reauthentication of the supplicants connected to the interface. By default, periodic authentication is disabled.
Step 4	<b>dot1x timeout re-authperiod seconds</b>  <b>Example:</b> switch(config-if)# dot1x timeout re-authperiod 3300	(Optional) Sets the number of seconds between reauthentication attempts. The default is 3600 seconds. The range is from 1 to 65535.  <b>Note</b> This command affects the behavior of the NX-OS device only if you enable periodic reauthentication on the interface.
Step 5	<b>exit</b>  <b>Example:</b> switch(config-if)# exit switch(config)#	(Optional) Exits configuration mode.
Step 6	<b>show dot1x all</b>  <b>Example:</b> switch(config)# show dot1x	(Optional) Displays all 802.1X feature status and configuration information.
Step 7	<b>copy running-config startup-config</b>  <b>Example:</b> switch(config)# copy running-config startup-config	(Optional) Copies the running configuration to the startup configuration.

## Manually Reauthenticating Supplicants

You can manually reauthenticate the supplicants for the entire NX-OS device or for an interface.



### Note

During the reauthentication process, the status of an already authenticated supplicant is not disrupted.

## BEFORE YOU BEGIN

Ensure that you are in the correct VDC (or use the **switchto vdc** command).

Enable the 802.1X feature on the NX-OS device (see the [“Enabling the 802.1X Feature”](#) section on page 7-10).

***Send document comments to [nexus7k-docfeedback@cisco.com](mailto:nexus7k-docfeedback@cisco.com)***

## SUMMARY STEPS

1. `dot1x re-authenticate [interface ethernet slot/port]`

## DETAILED STEPS

	Command	Purpose
Step 1	<code>dot1x re-authenticate [interface ethernet slot/port]</code>  <b>Example:</b> <code>switch# dot1x re-authenticate interface 2/1</code>	Reauthenticates the supplicants on the NX-OS device or on an interface.

## Manually Initializing 802.1X Authentication

You can manually initialize the authentication for all supplicants on an NX-OS device or for a specific interface.



### Note

Initializing the authentication clears any existing authentication status before starting the authentication process for the client.

## BEFORE YOU BEGIN

Ensure that you are in the correct VDC (or use the `switchto vdc` command).

Enable the 802.1X feature on the NX-OS device (see the [“Enabling the 802.1X Feature”](#) section on page 7-10).

## SUMMARY STEPS

1. `dot1x initialize [interface ethernet slot/port]`

## DETAILED STEPS

	Command	Purpose
Step 1	<code>dot1x initialize [interface ethernet slot/port]</code>  <b>Example:</b> <code>switch# dot1x initialize interface ethernet 2/1</code>	Initializes 802.1X authentication on the NX-OS device or on a specified interface.

***Send document comments to [nexus7k-docfeedback@cisco.com](mailto:nexus7k-docfeedback@cisco.com)***

## Changing Global 802.1X Authentication Timers

The following global 802.1X authentication timers are supported on the NX-OS device:

- Quiet-period timer—When the NX-OS device cannot authenticate the supplicant, the NX-OS device remains idle for a set period of time, and then tries again. The quiet-period timer value determines the idle period. An authentication failure might occur because the supplicant provided an invalid password. You can provide a faster response time to the user by entering a number smaller than the default. The default is 60 seconds. The range is from 1 to 65535.
- Switch-to-supplicant retransmission period timer—The client responds to the EAP-request/identity frame from the NX-OS device with an EAP-response/identity frame. If the NX-OS device does not receive this response, it waits a set period of time (known as the retransmission time) and then retransmits the frame. The default is 30. The range is from 1 to 65535 seconds.



### Note

You can also configure the quiet-period timer and switch-to-supplicant transmission period timer at the interface level (see the [“Changing 802.1X Authentication Timers for an Interface”](#) section on page 7-19).



### Note

You should change the default values only to adjust for unusual circumstances such as unreliable links or specific behavioral problems with certain supplicants and authentication servers.

## BEFORE YOU BEGIN

Ensure that you are in the correct VDC (or use the **switchto vdc** command).

Enable the 802.1X feature on the NX-OS device (see the [“Enabling the 802.1X Feature”](#) section on page 7-10).

## SUMMARY STEPS

1. **config t**
2. **dot1x timeout quiet-period *seconds***
3. **dot1x timeout tx-period *seconds***
4. **exit**
5. **show dot1x all**
6. **copy running-config startup-config**

***Send document comments to [nexus7k-docfeedback@cisco.com](mailto:nexus7k-docfeedback@cisco.com)***

## DETAILED STEPS

	Command	Purpose
Step 1	<code>config t</code>  <b>Example:</b> switch# config t switch(config)#	Enters global configuration mode.
Step 2	<code>dot1x timeout quiet-period seconds</code>  <b>Example:</b> switch(config)# dot1x timeout quiet-period 30	(Optional) Sets the number of seconds that the NX-OS device remains in the quiet state following a failed authentication exchange with any supplicant. The default is 60 seconds. The range is from 1 to 65535 seconds.
Step 3	<code>dot1x timeout tx-period seconds</code>  <b>Example:</b> switch(config)# dot1x timeout tx-period 20	(Optional) Sets the number of seconds that the NX-OS device waits for a response to an EAP-request/identity frame from the supplicant before retransmitting the request. The default is 30 seconds. The range is from 1 to 65535 seconds.
Step 4	<code>exit</code>  <b>Example:</b> switch(config-if)# exit switch(config)#	Exits configuration mode.
Step 5	<code>show dot1x all</code>  <b>Example:</b> switch(config)# show dot1x all	(Optional) Displays the 802.1X configuration.
Step 6	<code>copy running-config startup-config</code>  <b>Example:</b> switch(config)# copy running-config startup-config	(Optional) Copies the running configuration to the startup configuration.

## Changing 802.1X Authentication Timers for an Interface

You can change the following 802.1X authentication timers on the NX-OS device interfaces:

- Quiet-period timer—When the NX-OS device cannot authenticate the supplicant, the switch remains idle for a set period of time and then tries again. The quiet-period timer value determines the idle period. An authentication failure might occur because the supplicant provided an invalid password. You can provide a faster response time to the user by entering a smaller number than the default. The default is the value of the global quiet period timer. The range is from 1 to 65535 seconds.
- Rate-limit timer—The rate-limit period throttles EAPOL-Start packets from supplicants that are sending too many EAPOL-Start packets. The authenticator ignores EAPOL-Start packets from supplicants that have successfully authenticated for the rate-limit period duration. The default value is 0 seconds and the authenticator processes all EAPOL-Start packets. The range is from 1 to 65535 seconds.

## Send document comments to [nexus7k-docfeedback@cisco.com](mailto:nexus7k-docfeedback@cisco.com)

- Switch-to-authentication-server retransmission timer for Layer 4 packets—The authentication server notifies the switch each time that it receives a Layer 4 packet. If the switch does not receive a notification after sending a packet, the NX-OS device waits a set period of time and then retransmits the packet. The default is 30 seconds. The range is from 1 to 65535 seconds.
- Switch-to-suppliant retransmission timer for EAP response frames—The supplicant responds to the EAP-request/identity frame from the NX-OS device with an EAP-response/identity frame. If the NX-OS device does not receive this response, it waits a set period of time (known as the retransmission time) and then retransmits the frame. The default is 30 seconds. The range is from 1 to 65535 seconds.
- Switch-to-suppliant retransmission timer for EAP request frames—The supplicant notifies the NX-OS device it that received the EAP request frame. If the authenticator does not receive this notification, it waits a set period of time and then retransmits the frame. The default is the value of the global retransmission period timer. The range is from 1 to 65535 seconds.



### Note

You should change the default values only to adjust for unusual circumstances such as unreliable links or specific behavioral problems with certain supplicants and authentication servers.

## BEFORE YOU BEGIN

Ensure that you are in the correct VDC (or use the **switchto vdc** command).

Enable the 802.1X feature on the NX-OS device (see the [“Enabling the 802.1X Feature”](#) section on page 7-10).

## SUMMARY STEPS

1. **config t**
2. **interface ethernet *slot/port***
3. **dot1x timeout quiet-period *seconds***
4. **dot1x timeout ratelimit-period *seconds***
5. **dot1x timeout server-timeout *seconds***
6. **dot1x timeout supp-timeout *seconds***
7. **dot1x timeout tx-period *seconds***
8. **exit**
9. **show dot1x all**
10. **copy running-config startup-config**

**Send document comments to [nexus7k-docfeedback@cisco.com](mailto:nexus7k-docfeedback@cisco.com)**

## DETAILED STEPS

	Command	Purpose
Step 1	<b>config t</b>  <b>Example:</b> switch# config t switch(config)#	Enters global configuration mode.
Step 2	<b>interface ethernet slot/port</b>  <b>Example:</b> switch(config)# interface ethernet 2/1 switch(config-if)	Selects the interface to configure and enters interface configuration mode.
Step 3	<b>dot1x timeout quiet-period seconds</b>  <b>Example:</b> switch(config-if)# dot1x timeout quiet-period 25	(Optional) Sets the number of seconds that the authenticator waits for a response to an EAP-request/identity frame from the supplicant before retransmitting the request. The default is the global number of seconds set for all interfaces. The range is from 1 to 65535 seconds.
Step 4	<b>dot1x timeout ratelimit-period seconds</b>  <b>Example:</b> switch(config-if)# dot1x timeout ratelimit-period 10	(Optional) Sets the number of seconds that the authenticator ignores EAPOL-Start packets from supplicants that have successfully authenticated. The default value is 0 seconds. The range is from 1 to 65535 seconds.
Step 5	<b>dot1x timeout server-timeout seconds</b>  <b>Example:</b> switch(config-if)# dot1x timeout server-timeout 60	(Optional) Sets the number of seconds that the NX-OS device waits before retransmitting a packet to the authentication server. The default is 30 seconds. The range is from 1 to 65535 seconds.
Step 6	<b>dot1x timeout supp-timeout seconds</b>  <b>Example:</b> switch(config-if)# dot1x timeout supp-timeout 20	(Optional) Sets the number of seconds that the NX-OS device waits for the supplicant to respond to an EAP request frame before the NX-OS device retransmits the frame. The default is 30 seconds. The range is from 1 to 65535 seconds.
Step 7	<b>dot1x timeout tx-period seconds</b>  <b>Example:</b> switch(config-if)# dot1x timeout tx-period 40	(Optional) Sets the number of seconds between the retransmission of EAP request frames when the supplicant does not send notification that it received the request. The default is the global number of seconds set for all interfaces. The range is from 1 to 65535 seconds.
Step 8	<b>exit</b>  <b>Example:</b> switch(config)# exit switch#	Exits configuration mode.
Step 9	<b>show dot1x all</b>  <b>Example:</b> switch# show dot1x all	(Optional) Displays the 802.1X configuration.
Step 10	<b>copy running-config startup-config</b>  <b>Example:</b> switch# copy running-config startup-config	(Optional) Copies the running configuration to the startup configuration.

***Send document comments to [nexus7k-docfeedback@cisco.com](mailto:nexus7k-docfeedback@cisco.com)***

## Enabling Single Host or Multiple Hosts Mode

You can enable single host or multiple hosts mode on an interface.

### BEFORE YOU BEGIN

Ensure that you are in the correct VDC (or use the **switchto vdc** command).

Enable the 802.1X feature on the NX-OS device (see the “[Enabling the 802.1X Feature](#)” section on [page 7-10](#)).

### SUMMARY STEPS

1. **config t**
2. **interface ethernet *slot/port***
3. **dot1x host-mode {multi-host | single-host}**
4. **exit**
5. **show dot1x all**
6. **copy running-config startup-config**

### DETAILED STEPS

	Command	Purpose
Step 1	<b>config t</b>  <b>Example:</b> switch# config t switch(config)#	Enters global configuration mode.
Step 2	<b>interface ethernet <i>slot/port</i></b>  <b>Example:</b> switch(config)# interface ethernet 2/1 switch(config-if)	Selects the interface to configure and enters interface configuration mode.

**Send document comments to [nexus7k-docfeedback@cisco.com](mailto:nexus7k-docfeedback@cisco.com)**

	Command	Purpose
Step 3	<b>dot1x host-mode</b> {multi-host   single-host}  <b>Example:</b> switch(config-if)# dot1x host-mode multi-host	Configures the host mode. The default is <b>single-host</b> .  <b>Note</b> Make sure that the <b>dot1x port-control</b> interface configuration command is set to <b>auto</b> for the specified interface.
Step 4	<b>exit</b>  <b>Example:</b> switch(config-if)# exit switch(config)#	Exits configuration mode.
Step 5	<b>show dot1x all</b>  <b>Example:</b> switch# show dot1x all	(Optional) Displays all 802.1X feature status and configuration information.
Step 6	<b>copy running-config startup-config</b>  <b>Example:</b> switch(config)# copy running-config startup-config	(Optional) Copies the running configuration to the startup configuration.

## Enabling MAC Address Authentication Bypass

You can enable MAC address authentication bypass on an interface that has no supplicant connected.

### BEFORE YOU BEGIN

Ensure that you are in the correct VDC (or use the **switchto vdc** command).

Enable the 802.1X feature on the NX-OS device (see the “[Enabling the 802.1X Feature](#)” section on page 7-10).

### SUMMARY STEPS

1. **config t**
2. **interface ethernet slot/port**
3. **dot1x mac-auth-bypass [eap]**
4. **exit**
5. **show dot1x all**
6. **copy running-config startup-config**

**Send document comments to [nexus7k-docfeedback@cisco.com](mailto:nexus7k-docfeedback@cisco.com)**

## DETAILED STEPS

	Command	Purpose
Step 1	<b>config t</b>  <b>Example:</b> switch# config t switch(config)#	Enters global configuration mode.
Step 2	<b>interface ethernet slot/port</b>  <b>Example:</b> switch(config)# interface ethernet 2/1 switch(config-if)	Selects the interface to configure and enters interface configuration mode.
Step 3	<b>dot1x mac-auth-bypass [eap]</b>  <b>Example:</b> switch(config-if)# dot1x mac-auth-bypass	Enables MAC address authentication bypass. The default is bypass disabled. Use the <b>eap</b> keyword to configure the NX-OS device to use EAP for authorization.
Step 4	<b>exit</b>  <b>Example:</b> switch(config-if)# exit switch(config)#	Exits configuration mode.
Step 5	<b>show dot1x all</b>  <b>Example:</b> switch# show dot1x all	(Optional) Displays all 802.1X feature status and configuration information.
Step 6	<b>copy running-config startup-config</b>  <b>Example:</b> switch(config)# copy running-config startup-config	(Optional) Copies the running configuration to the startup configuration.

## Disabling 802.1X Authentication on the NX-OS Device

You can disable 802.1X authentication on the NX-OS device. By default, the NX-OS software enables 802.1X authentication after you enable the 802.1X feature. However, when you disable the 802.1x feature, the configuration is removed from the NX-OS device. The NX-OS software allow you to disable 802.1X authentication without losing the 802.1X configuration.



### Note

When you disable 802.1X authentication, the port mode for all interfaces defaults to force-authorized regardless of the configured port mode (see the [“Controlling 802.1X Authentication on an Interface” section on page 7-12](#)). When you reenables 802.1X authentication, the NX-OS software restores the configured port mode on the interfaces.

## BEFORE YOU BEGIN

Ensure that you are in the correct VDC (or use the **switchto vdc** command).

Enable the 802.1X feature on the NX-OS device (see the [“Enabling the 802.1X Feature” section on page 7-10](#)).

***Send document comments to [nexus7k-docfeedback@cisco.com](mailto:nexus7k-docfeedback@cisco.com)***

## SUMMARY STEPS

1. `config t`
2. `no dot1x system-auth-control`
3. `exit`
4. `show dot1x`
5. `copy running-config startup-config`

## DETAILED STEPS

	Command	Purpose
Step 1	<code>config t</code>  <b>Example:</b> switch# <code>config t</code> switch(config)#	Enters global configuration mode.
Step 2	<code>no dot1x system-auth-control</code>  <b>Example:</b> switch(config)# <code>no dot1x system-auth-control</code>	Disables 802.1X authentication on the NX-OS device. The default is enabled.  <b>Note</b> Use the <code>dot1x system-auth-control</code> command to enable 802.1X authentication on the NX-OS device.
Step 3	<code>exit</code>  <b>Example:</b> switch(config)# <code>exit</code> switch#	Exits configuration mode.
Step 4	<code>show dot1x</code>  <b>Example:</b> switch# <code>show dot1x</code>	(Optional) Displays the 802.1X feature status.
Step 5	<code>copy running-config startup-config</code>  <b>Example:</b> switch# <code>copy running-config startup-config</code>	(Optional) Copies the running configuration to the startup configuration.

## Disabling the 802.1X Feature

You can disable the 802.1X feature on the NX-OS device.



### Caution

Disabling 802.1X removes all 802.1X configuration from the NX-OS device. If you want to stop 802.1X authentication, see the [“Disabling 802.1X Authentication on the NX-OS Device”](#) section on page 7-24.

## BEFORE YOU BEGIN

Ensure that you are in the correct VDC (or use the `switchto vdc` command).

Enable the 802.1X feature on the NX-OS device (see the [“Enabling the 802.1X Feature”](#) section on page 7-10).

***Send document comments to [nexus7k-docfeedback@cisco.com](mailto:nexus7k-docfeedback@cisco.com)***

## SUMMARY STEPS

1. `config t`
2. `no feature dot1x`
3. `exit`
4. `copy running-config startup-config`

## DETAILED STEPS

	Command	Purpose
Step 1	<code>config t</code>  <b>Example:</b> switch# <code>config t</code> switch(config)#	Enters global configuration mode.
Step 2	<code>no feature dot1x</code>  <b>Example:</b> switch(config)# <code>no feature dot1x</code>	Disables 802.1X.   <b>Caution</b> Disabling the 802.1X feature removes all 802.1X configuration.
Step 3	<code>exit</code>  <b>Example:</b> switch(config)# <code>exit</code> switch#	Exits configuration mode.
Step 4	<code>copy running-config startup-config</code>  <b>Example:</b> switch# <code>copy running-config startup-config</code>	(Optional) Copies the running configuration to the startup configuration.

## Resetting the 802.1X Global Configuration to the Default Values

You can set the 802.1X global configuration to the default values.

### BEFORE YOU BEGIN

Ensure that you are in the correct VDC (or use the `switchto vdc` command).

Enable the 802.1X feature on the NX-OS device (see the “[Enabling the 802.1X Feature](#)” section on page 7-10).

## SUMMARY STEPS

1. `config t`
2. `dot1x default`
3. `exit`

***Send document comments to [nexus7k-docfeedback@cisco.com](mailto:nexus7k-docfeedback@cisco.com)***

4. `show dot1x all`
5. `copy running-config startup-config`

## DETAILED STEPS

	Command	Purpose
Step 1	<code>config t</code>  <b>Example:</b> switch# <code>config t</code> switch(config)#	Enters global configuration mode.
Step 2	<code>dot1x default</code>  <b>Example:</b> switch(config)# <code>dot1x default</code>	Reverts to the 802.1X global configuration default values.
Step 3	<code>exit</code>  <b>Example:</b> switch(config)# <code>exit</code> switch#	Exits configuration mode.
Step 4	<code>show dot1x all</code>  <b>Example:</b> switch# <code>show dot1x all</code>	(Optional) Displays all 802.1X feature status and configuration information.
Step 5	<code>copy running-config startup-config</code>  <b>Example:</b> switch# <code>copy running-config startup-config</code>	(Optional) Copies the running configuration to the startup configuration.

## Resetting the 802.1X Interface Configuration to the Default Values

You can reset the 802.1X configuration for an interface to the default values.

### BEFORE YOU BEGIN

Ensure that you are in the correct VDC (or use the `switchto vdc` command).

Enable the 802.1X feature on the NX-OS device (see the [“Enabling the 802.1X Feature”](#) section on page 7-10).

### SUMMARY STEPS

1. `config t`
2. `interface ethernet slot/port`
3. `dot1x default`
4. `exit`
5. `show dot1x all`
6. `copy running-config startup-config`

**Send document comments to [nexus7k-docfeedback@cisco.com](mailto:nexus7k-docfeedback@cisco.com)**

## DETAILED STEPS

	Command	Purpose
Step 1	<b>config t</b>  <b>Example:</b> switch# config t switch(config)#	Enters global configuration mode.
Step 2	<b>interface ethernet slot/port</b>  <b>Example:</b> switch(config)# interface ethernet 2/1 switch(config-if)	Selects the interface to configure and enters interface configuration mode.
Step 3	<b>dot1x default</b>  <b>Example:</b> switch(config-if)# dot1x default	Reverts to the 802.1X configuration default values for the interface.
Step 4	<b>exit</b>  <b>Example:</b> switch(config-if)# exit switch(config)#	Exits configuration mode.
Step 5	<b>show dot1x all</b>  <b>Example:</b> switch(config)# show dot1x all	(Optional) Displays all 802.1X feature status and configuration information.
Step 6	<b>copy running-config startup-config</b>  <b>Example:</b> switch(config)# copy running-config startup-config	(Optional) Copies the running configuration to the startup configuration.

## Setting the Global Maximum Authenticator-to-Supplicant Frame Retransmission Retry Count

In addition to changing the authenticator-to-suppliant retransmission time, you can set the number of times that the NX-OS device sends an EAP-request/identity frame (assuming no response is received) to the supplicant before restarting the authentication process.



### Note

You should change the default value of this command only to adjust for unusual circumstances such as unreliable links or specific behavioral problems with certain supplicants and authentication servers.

## BEFORE YOU BEGIN

Ensure that you are in the correct VDC (or use the **switchto vdc** command).

Enable the 802.1X feature on the NX-OS device (see the [“Enabling the 802.1X Feature”](#) section on page 7-10).

***Send document comments to [nexus7k-docfeedback@cisco.com](mailto:nexus7k-docfeedback@cisco.com)***

## SUMMARY STEPS

1. `config t`
2. `dot1x max-req retry-count`
3. `exit`
4. `show dot1x all`
5. `copy running-config startup-config`

## DETAILED STEPS

	Command	Purpose
Step 1	<code>config t</code>  <b>Example:</b> switch# <code>config t</code> switch(config)#	Enters global configuration mode.
Step 2	<code>dot1x max-req <i>retry-count</i></code>  <b>Example:</b> switch(config)# <code>dot1x max-req 3</code>	Changes the maximum request retry count before restarting the 802.1X authentication process. The default is 2 and the range is from 1 to 10.  <b>Note</b> Make sure that the <code>dot1x port-control</code> interface configuration command is set to <b>auto</b> for the specified interface.
Step 3	<code>exit</code>  <b>Example:</b> switch(config)# <code>exit</code> switch#	Exits configuration mode.
Step 4	<code>show dot1x all</code>  <b>Example:</b> switch(config)# <code>show dot1x all</code>	(Optional) Displays all 802.1X feature status and configuration information.
Step 5	<code>copy running-config startup-config</code>  <b>Example:</b> switch# <code>copy running-config startup-config</code>	(Optional) Copies the running configuration to the startup configuration.

## Configuring the Maximum Authenticator-to-Supplicant Frame Retransmission Retry Count for an Interface

You can configure the maximum number of times that the NX-OS device retransmits authentication requests to the supplicant on an interface before the session times out. The default is 2 times and the range is from 1 to 10.

### BEFORE YOU BEGIN

Ensure that you are in the correct VDC (or use the `switchto vdc` command).

Enable the 802.1X feature on the NX-OS device (see the [“Enabling the 802.1X Feature”](#) section on page 7-10).

**Send document comments to [nexus7k-docfeedback@cisco.com](mailto:nexus7k-docfeedback@cisco.com)**

## SUMMARY STEPS

1. `config t`
2. `interface ethernet slot/port`
3. `dot1x max-req count`
4. `exit`
5. `show dot1x all`
6. `copy running-config startup-config`

## DETAILED STEPS

	Command	Purpose
Step 1	<code>config t</code>  <b>Example:</b> switch# config t switch(config)#	Enters global configuration mode.
Step 2	<code>interface ethernet slot/port</code>  <b>Example:</b> switch(config)# interface ethernet 2/1 switch(config-if)#	Selects the interface to configure and enters interface configuration mode.
Step 3	<code>dot1x max-req count</code>  <b>Example:</b> switch(config-if)# dot1x max-req 3	Changes the maximum authorization request retry count. The default is 2 times and the range is from 1 to 10.
Step 4	<code>exit</code>  <b>Example:</b> switch(config)# exit switch#	Exits interface configuration mode.
Step 5	<code>show dot1x all</code>  <b>Example:</b> switch# show dot1x all	(Optional) Displays all 802.1X feature status and configuration information.
Step 6	<code>copy running-config startup-config</code>  <b>Example:</b> switch(config)# copy running-config startup-config	(Optional) Copies the running configuration to the startup configuration.

## Enabling RADIUS Accounting for 802.1X Authentication

You can enable RADIUS accounting for the 802.1X authentication activity.

### BEFORE YOU BEGIN

Ensure that you are in the correct VDC (or use the `switchto vdc` command).

Enable the 802.1X feature on the NX-OS device (see the [“Enabling the 802.1X Feature”](#) section on page 7-10).

***Send document comments to [nexus7k-docfeedback@cisco.com](mailto:nexus7k-docfeedback@cisco.com)***

## SUMMARY STEPS

1. `config t`
2. `dot1x radius-accounting`
3. `exit`
4. `show dot1x`
5. `copy running-config startup-config`

## DETAILED STEPS

	Command	Purpose
Step 1	<code>config t</code>  <b>Example:</b> switch# <code>config t</code> switch(config)#	Enters global configuration mode.
Step 2	<code>dot1x radius-accounting</code>  <b>Example:</b> switch(config)# <code>dot1x radius-accounting</code>	Enables RADIUS accounting for 802.1X. The default is disabled.
Step 3	<code>exit</code>  <b>Example:</b> switch(config)# <code>exit</code> switch#	Exits configuration mode.
Step 4	<code>show dot1x</code>  <b>Example:</b> switch# <code>show dot1x</code>	(Optional) Displays the 802.1X configuration.
Step 5	<code>copy running-config startup-config</code>  <b>Example:</b> switch# <code>copy running-config startup-config</code>	(Optional) Copies the running configuration to the startup configuration.

## Configuring AAA Accounting Methods for 802.1X

You can enable AAA accounting Methods for the 802.1X feature.

### BEFORE YOU BEGIN

Ensure that you are in the correct VDC (or use the `switchto vdc` command).

Enable the 802.1X feature on the NX-OS device (see the [“Enabling the 802.1X Feature”](#) section on page 7-10).

## SUMMARY STEPS

1. `config t`
2. `aaa accounting dot1x default group group-list`
3. `exit`

**Send document comments to [nexus7k-docfeedback@cisco.com](mailto:nexus7k-docfeedback@cisco.com)**

4. `show aaa accounting`
5. `copy running-config startup-config`

## DETAILED STEPS

	Command	Purpose
Step 1	<pre>config t</pre> <p><b>Example:</b>  <pre>switch# config t switch(config)#</pre></p>	Enters global configuration mode.
Step 2	<pre>aaa accounting dot1x default group group-list</pre> <p><b>Example:</b>  <pre>switch(config)# dot1x aaa accounting default group radius</pre></p>	<p>Configures AAA accounting for 802.1X. The default is disabled.</p> <p>The <i>group-list</i> argument consists of a space-delimited list of group names. The group names are the following:</p> <ul style="list-style-type: none"> <li>• <b>radius</b>—Uses the global pool of RADIUS servers for authentication.</li> <li>• <i>named-group</i>—Uses a named subset of RADIUS servers for authentication.</li> </ul>
Step 3	<pre>exit</pre> <p><b>Example:</b>  <pre>switch(config)# exit switch#</pre></p>	Exits configuration mode.
Step 4	<pre>show aaa accounting</pre> <p><b>Example:</b>  <pre>switch# show aaa accounting</pre></p>	(Optional) Displays the AAA accounting configuration.
Step 5	<pre>copy running-config startup-config</pre> <p><b>Example:</b>  <pre>switch# copy running-config startup-config</pre></p>	(Optional) Copies the running configuration to the startup configuration.

## Setting the Maximum Reauthentication Retry Count on an Interface

You can set the maximum number of times that the NX-OS device retransmits reauthentication requests to the supplicant on an interface before the session times out. The default is 2 times and the range is from 1 to 10.

### BEFORE YOU BEGIN

Ensure that you are in the correct VDC (or use the `switchto vdc` command).

Enable the 802.1X feature on the NX-OS device (see the [“Enabling the 802.1X Feature”](#) section on page 7-10).

***Send document comments to [nexus7k-docfeedback@cisco.com](mailto:nexus7k-docfeedback@cisco.com)***

## SUMMARY STEPS

1. `config t`
2. `interface ethernet slot/port`
3. `dot1x max-reauth-req retry-count`
4. `exit`
5. `show dot1x all`
6. `copy running-config startup-config`

## DETAILED STEPS

	Command	Purpose
Step 1	<code>config t</code>  <b>Example:</b> switch# config t switch(config)#	Enters global configuration mode.
Step 2	<code>interface ethernet slot/port</code>  <b>Example:</b> switch(config)# interface ethernet 2/1 switch(config-if)#	Selects the interface to configure and enters interface configuration mode.
Step 3	<code>dot1x max-reauth-req retry-count</code>  <b>Example:</b> switch(config-if)# dot1x max-reauth-req 3	Changes the maximum reauthentication request retry count. The default is 2 times and the range is from 1 to 10.
Step 4	<code>exit</code>  <b>Example:</b> switch(config)# exit switch#	Exits interface configuration mode.
Step 5	<code>show dot1x all</code>  <b>Example:</b> switch# show dot1x all	(Optional) Displays all 802.1X feature status and configuration information.
Step 6	<code>copy running-config startup-config</code>  <b>Example:</b> switch(config)# copy running-config startup-config	(Optional) Copies the running configuration to the startup configuration.

[Send document comments to nexus7k-docfeedback@cisco.com](mailto:nexus7k-docfeedback@cisco.com)

## Verifying the 802.1X Configuration

To display 802.1X information, perform one of the following tasks:

Command	Purpose
<code>show dot1x</code>	Displays the 802.1X feature status.
<code>show dot1x all [details   statistics   summary]</code>	Displays all 802.1X feature status and configuration information.
<code>show dot1x interface ethernet slot/port [details   statistics   summary]</code>	Display the 802.1X feature status and configuration information for an Ethernet interface.
<code>show running-config dot1x [all]</code>	Displays the 802.1X feature configuration in the running configuration.
<code>show startup-config dot1x</code>	Displays the 802.1X feature configuration in the startup configuration.

For detailed information about the fields in the output from these commands, see the [Cisco Nexus 7000 Series NX-OS Security Command Reference, Release 4.0](#).

## Displaying 802.1X Statistics

You can display the statistics that the NX-OS device maintains for the 802.1X activity.

### BEFORE YOU BEGIN

Ensure that you are in the correct VDC (or use the `switchto vdc` command).

Enable the 802.1X feature on the NX-OS device (see the “[Enabling the 802.1X Feature](#)” section on page 7-10).

### SUMMARY STEPS

1. `show dot1x {all | interface ethernet slot/port} statistics`

### DETAILED STEPS

	Command	Purpose
Step 1	<pre>switch# show dot1x {all   interface ethernet slot/port} statistics</pre> <p><b>Example:</b></p> <pre>switch# show dot1x all statistics</pre>	Displays the 802.1X statistics.

For detailed information about the fields in the output from this command, see the [Cisco Nexus 7000 Series NX-OS Security Command Reference, Release 4.0](#).

[Send document comments to nexus7k-docfeedback@cisco.com](mailto:nexus7k-docfeedback@cisco.com)

## 802.1X Example Configurations

The following example shows how to configure 802.1X:

```
feature dot1x
aaa authentication dot1x default group rad2
interface Ethernet2/1
    dot1x port-control auto
```



**Note**

Repeat the **dot1x port-control auto** command for all interfaces that require 802.1X authentication.

## Default Settings

Table 7-1 lists the default settings for 802.1X parameters.

**Table 7-1** Default 802.1X Parameters

Parameters	Default
802.1X feature	Disabled
AAA 802.1X authentication method	Not configured
Per-interface 802.1X protocol enable state	Disabled ( <b>force-authorized</b> ) <b>Note</b> The port transmits and receives normal traffic without 802.1X-based authentication of the supplicant.
Periodic reauthentication	Disabled
Number of seconds between reauthentication attempts	3600 seconds
Quiet timeout period	60 seconds (number of seconds that the NX-OS device remains in the quiet state following a failed authentication exchange with the supplicant)
Retransmission timeout period	30 seconds (number of seconds that the NX-OS device should wait for a response to an EAP request/identity frame from the supplicant before retransmitting the request)
Maximum retransmission number	2 times (number of times that the NX-OS device will send an EAP-request/identity frame before restarting the authentication process)
Host mode	Single host
Supplicant timeout period	30 seconds (when relaying a request from the authentication server to the supplicant, the amount of time that the NX-OS device waits for a response before retransmitting the request to the supplicant)
Authentication server timeout period	30 seconds (when relaying a response from the supplicant to the authentication server, the amount of time that the NX-OS device waits for a reply before retransmitting the response to the server)

***Send document comments to [nexus7k-docfeedback@cisco.com](mailto:nexus7k-docfeedback@cisco.com)***

## Additional References

For additional information related to implementing 802.1X, see the following sections:

- [Related Documents, page 7-36](#)
- [Standards, page 7-36](#)
- [MIBs, page 7-36](#)

## Related Documents

Related Topic	Document Title
NX-OS Licensing	<i>Cisco Nexus 7000 Series NX-OS Licensing Guide, Release 4.0</i>
Command reference	<i>Cisco Nexus 7000 Series NX-OS Security Command Reference, Release 4.0</i>
VRF configuration	<i>Cisco Nexus 7000 Series NX-OS Unicast Routing Configuration Guide, Release 4.0</i>

## Standards

Standards	Title
IEEE Std 802.1X- 2004 (Revision of IEEE Std 802.1X-2001)	<i>802.1X IEEE Standard for Local and Metropolitan Area Networks Port-Based Network Access Control</i>
RFC 2284	<i>PPP Extensible Authentication Protocol (EAP)</i>
RFC 3580	<i>IEEE 802.1X Remote Authentication Dial In User Service (RADIUS) Usage Guidelines</i>

## MIBs

MIBs	MIBs Link
<ul style="list-style-type: none"> <li>• IEEE8021-PAE-MIB</li> </ul>	To locate and download MIBs, go to the following URL: <a href="http://www.cisco.com/public/sw-center/netmgmt/cmtk/mibs.shtml">http://www.cisco.com/public/sw-center/netmgmt/cmtk/mibs.shtml</a>