



## CHAPTER 5

# Configuring Port Channels

---

This chapter describes how to configure port channels and to apply and configure the Link Aggregation Control Protocol (LACP) for more efficient use of port channels in the Cisco NX-OS software.

This chapter includes the following sections:

- [Information About Port Channels, page 5-1](#)
- [Licensing Requirements for Port Channeling, page 5-11](#)
- [Prerequisites for Port Channeling, page 5-12](#)
- [Guidelines and Limitations, page 5-12](#)
- [Configuring Port Channels, page 5-13](#)
- [Verifying Port-Channel Configuration, page 5-31](#)
- [Displaying Statistics, page 5-31](#)
- [Port Channel Example Configuration, page 5-32](#)
- [Default Settings, page 5-32](#)
- [Additional References, page 5-33](#)

## Information About Port Channels

A port channel is an aggregation of multiple physical interfaces that creates a logical interface. You can bundle up to eight individual active links into a port channel to provide increased bandwidth and redundancy. Port channeling also load balances traffic across these physical interfaces. The port channel stays operational as long as at least one physical interface within the port channel is operational.

You can create a Layer 2 port channel by bundling compatible Layer 2 interfaces, or you can create Layer 3 port channels by bundling compatible Layer 3 interfaces. After you create a Layer 3 port channel, you can add an IP address to the port-channel interface and create subinterfaces on the Layer 3 port channel. You cannot combine Layer 2 and Layer 3 interfaces in the same port channel.

All ports in the port channel must be in the same virtual device context (VDC); you cannot configure port channels across VDCs.

You can also change the port channel from Layer 3 to Layer 2. See [Chapter 3, “Configuring Layer 2 Interfaces,”](#) for information on creating Layer 2 interfaces.

Any configuration changes that you apply to the port channel are applied to each member interface of that port channel. For example, if you configure Spanning Tree Protocol (STP) parameters on the port channel, the Cisco NX-OS applies those parameters to each interface in the port channel.

## Send document comments to [nexus7k-docfeedback@cisco.com](mailto:nexus7k-docfeedback@cisco.com)

You can create subinterfaces on a Layer 3 port channel, even though a subinterface is part of the logical port-channel interface. See the “[Subinterfaces](#)” section on page 4-2 for more information on port-channel subinterfaces.

You can use static port channels, with no associated aggregation protocol, for a simplified configuration.

For more flexibility, you can use the Link Aggregation Control Protocol (LACP), which is defined in IEEE 802.3ad. When you use LACP, the link passes protocol packets.

See the “[LACP Overview](#)” section on page 5-7 for information on LACP.

This section includes the following topics:

- [Port Channels](#), page 5-2
- [Port-Channel Interfaces](#), page 5-3
- [Basic Settings](#), page 5-3
- [Compatibility Requirements](#), page 5-4
- [Load Balancing Using Port Channels](#), page 5-6
- [LACP](#), page 5-7
- [Virtualization Support](#), page 5-11
- [High Availability](#), page 5-11

## Port Channels

A port channel bundles physical links into a channel group to create a single logical link that provides the aggregate bandwidth of up to eight physical links. If a member port within a port channel fails, the traffic previously carried over the failed link switches to the remaining member ports within the port channel.

You can bundle up to eight ports into a static port channel without using any aggregation protocol. However, you can enable the LACP to use port channels more flexibly. Configuring port channels with LACP and static port channels require slightly different steps (see the “[Configuring Port Channels](#)” section on page 5-13).

**Note**

---

The device does not support Port Aggregation Protocol (PAgP) for port channels.

---

Each port can be in only one port channel. All the ports in a port channel must be compatible; they must use the same speed and duplex mode (see the “[Compatibility Requirements](#)” section on page 5-4). When you run static port channels with no aggregation protocol, the physical links are all in the **on** channel mode; you cannot change this mode without enabling LACP (see the “[Port-Channel Modes](#)” section on page 5-8).

You can create port channels directly by creating the port-channel interface, or you can create a channel group that acts to aggregate individual ports into a bundle. When you associate an interface with a channel group, the software creates a matching port channel automatically if the port channel does not already exist. In this instance, the port channel assumes the Layer 2 or Layer 3 configuration of the first interface. You can also create the port channel first. In this instance, the Cisco NX-OS creates an empty channel group with the same channel number as the port channel and takes the default Layer 2 or Layer 3 configuration, as well as the compatibility configuration (see the “[Compatibility Requirements](#)” section on page 5-4). See Chapter 4, “[Configuring Layer 3 Interfaces](#)” for more information on creating and deleting port-channel subinterfaces.

[Send document comments to nexus7k-docfeedback@cisco.com](mailto:nexus7k-docfeedback@cisco.com)

**Note**

The port channel is operationally up when at least one of the member ports is up and that port's status is channeling. The port channel is operationally down when all member ports are operationally down.

## Port-Channel Interfaces

Figure 5-1 shows port-channel interfaces.

**Figure 5-1** Port-Channel Interfaces

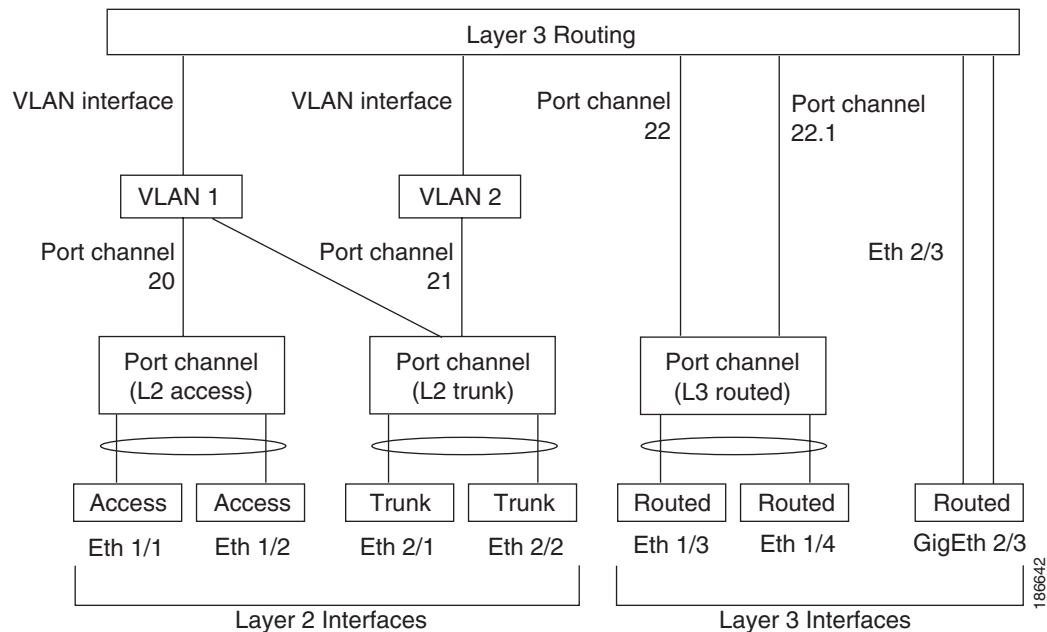

You can classify port-channel interfaces as Layer 2 or Layer 3 interfaces. In addition, you can configure Layer 2 port channels in either access or trunk mode. Layer 3 port-channel interfaces have routed ports as channel members and may have subinterfaces.

See [Chapter 3, “Configuring Layer 2 Interfaces”](#) for information on configuring Layer 2 ports in access or trunk mode and [Chapter 4, “Configuring Layer 3 Interfaces”](#) for information on configuring Layer 3 interfaces and subinterfaces.

## Basic Settings

You can configure the following basic settings for the port-channel interface:

- Bandwidth—You set this for only informational purposes; this setting is to be used by higher-level protocols.
- Delay—You set this for only informational purposes; this setting is to be used by higher-level protocols.
- Description.
- Duplex.

***Send document comments to [nexus7k-docfeedback@cisco.com](mailto:nexus7k-docfeedback@cisco.com)***

- Flow control.
- IP addresses—Both IPv4 and IPv6.
- Maximum Transmission Unit (MTU). (See [Chapter 2, “Configuring Basic Interface Parameters”](#) for information on configuring MTU.)
- Shutdown.
- Speed.

## Compatibility Requirements

When you add an interface to a channel group, the Cisco NX-OS checks certain interface attributes to ensure that the interface is compatible with the channel group. For example, you cannot add a Layer 3 interface to a Layer 2 channel group. The Cisco NX-OS also checks a number of operational attributes for an interface before allowing that interface to participate in the port-channel aggregation.

The compatibility check includes the following operational attributes:

- Network layer
- (Link) speed capability
- Speed configuration
- Duplex capability
- Duplex configuration
- Port mode
- Access VLAN
- Trunk native VLAN
- Tagged or untagged
- Allowed VLAN list
- MTU size
- SPAN—cannot be a SPAN source or a destination port
- Layer 3 ports cannot have subinterfaces
- Storm control
- Flow-control capability
- Flow-control configuration

Use the **show port-channel compatibility-parameters** command to see the full list of compatibility checks that the Cisco NX-OS uses.

You can only add interfaces configured with the channel mode set to **on** to static port channels. And you can only add interfaces configured with the channel mode as **active** or **passive** to port channels that are running LACP. (See the [“LACP Marker Responders”](#) section on page 5-10 for information on port-channel modes.) You can configure these attributes on an individual member port. If you configure a member port with an incompatible attribute, the Cisco NX-OS suspends that port in the port channel.

Alternatively, you can force ports with incompatible parameters to join the port channel if the following parameters are the same:

- (Link) speed capability
- Speed configuration

***Send document comments to [nexus7k-docfeedback@cisco.com](mailto:nexus7k-docfeedback@cisco.com)***

- Duplex capability
- Duplex configuration
- Flow-control capability
- Flow- control configuration

When the interface joins a port channel, some of its individual parameters are removed and replaced with the values on the port channel as follows:

- Bandwidth
- Delay
- Extended Authentication Protocol over UDP
- VRF
- IP address (v4 and v6)
- MAC address
- Spanning Tree Protocol
- NAC
- Service policy
- Quality of Service (QoS)
- Access control lists (ACLs)

Many interface parameters remain unaffected when the interface joins or leaves a port channel as follows:

- Beacon
- Description
- CDP
- LACP port priority
- Debounce
- UDLD
- MDIX
- Rate mode
- Shutdown
- SNMP trap

If you configure subinterfaces for the port-channel interface and remove a member port from the port channel, the configuration of the port-channel subinterface does not propagate to the member ports.

**Note**

---

When you delete the port channel, the software sets all member interfaces as if they were removed from the port channel.

---

*Send document comments to [nexus7k-docfeedback@cisco.com](mailto:nexus7k-docfeedback@cisco.com)*

## Load Balancing Using Port Channels

The Cisco NX-OS load balances traffic across all operational interfaces in a port channel by hashing the addresses in the frame to a numerical value that selects one of the links in the channel. Port channels provide load balancing by default. Port-channel load-balancing uses MAC addresses, IP addresses, or Layer 4 port numbers to select the link. Port-channel load balancing uses either source or destination addresses or ports, or both source and destination addresses or ports.

You can configure the load-balancing mode to apply to all port channels that are configured on the entire device or on specified modules. The per-module configuration takes precedence over the load-balancing configuration for the entire device. You can configure one load-balancing mode for the entire device, a different mode for specified modules, and another mode for the other specified modules. You cannot configure the load-balancing method per port channel.

You can configure the type of load-balancing algorithm used. You can choose the load-balancing algorithm that determines which member port to select for egress traffic by looking at the fields in the frame.

**Note**

---

The default load-balancing mode for Layer 3 interfaces is the source and destination IP address, and the default load-balancing mode for non-IP interfaces is the source and destination MAC address.

---

You can configure the device to use one of the following methods to load balance across the port channel:

- Destination MAC address
- Source MAC address
- Source and destination MAC address
- Destination IP address
- Source IP address
- Source and destination IP address
- Source TCP/UDP port number
- Destination TCP/UDP port number
- Source and destination TCP/UDP port number

Non-IP and Layer 3 port channels both follow the configured load-balancing method, using the source, destination, or source and destination parameters. For example, when you configure load balancing to use the source IP address, all non-IP traffic uses the source MAC address to load balance the traffic while the Layer 3 traffic load balances the traffic using the source IP address. Similarly, when you configure the destination MAC address as the load-balancing method, all Layer 3 traffic uses the destination IP address while the non-IP traffic load balances using the destination MAC address.

**Note**

---

You cannot configure load balancing using port channels per VDC. You must be in the default VDC to configure this feature; if you attempt to configure this feature from another VDC, the system returns an error.

---

You can configure load balancing either by the entire system or by specific modules, regardless of the VDC.

If the ingress traffic is Multiprotocol Label Switching (MPLS) traffic, the software looks under the labels for the IP address on the packet.

## ***Send document comments to [nexus7k-docfeedback@cisco.com](mailto:nexus7k-docfeedback@cisco.com)***

The load-balancing algorithms that use port channels do not apply to multicast traffic. Regardless of the load-balancing algorithm you have configured, multicast traffic uses the following methods for load balancing with port channels:

- Multicast traffic with Layer 4 information—Source IP address, source port, destination IP address, destination port
- Multicast traffic without Layer 4 information—Source IP address, destination IP address
- Non-IP multicast traffic—Source MAC address, destination MAC address

## **LACP**

LACP allows you to configure up to 16 interfaces into a port channel. A maximum of eight interfaces can be active, and a maximum of eight interfaces can be laced in a standby state.

This section includes the following topics:

- [LACP Overview, page 5-7](#)
- [Port-Channel Modes, page 5-8](#)
- [LACP ID Parameters, page 5-9](#)
- [LACP Marker Responders, page 5-10](#)
- [LACP-Enabled and Static Port Channels Differences, page 5-10](#)

## **LACP Overview**

**Note**

---

You must enable LACP before you can use LACP. By default, LACP is disabled.

---

**Send document comments to [nexus7k-docfeedback@cisco.com](mailto:nexus7k-docfeedback@cisco.com)**

See the “Enabling LACP” section on page 5-26 for information on enabling LACP.

Figure 5-2 shows how individual links can be combined into LACP port channels and channel groups as well as function as individual links.

**Figure 5-2 Individual Links Combined into a Port Channel**

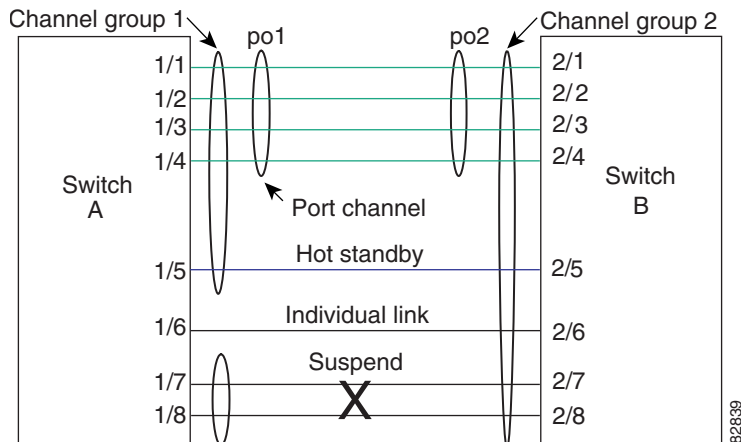

With LACP, you can bundle up to 16 interfaces in a channel group. If the channel group has more than eight interfaces, the remaining interfaces are in hot standby for the port channel associated with this channel group.



**Note**

When you delete the port channel, the software automatically deletes the associated channel group. All member interfaces revert to their original configuration.

You cannot disable LACP while any LACP configurations are present.

## Port-Channel Modes

Individual interfaces in port channels are configured with channel modes. When you run static port channels with no aggregation protocol, the channel mode is always set to **on**.

After you enable LACP globally on the device, you enable LACP for each channel by setting the channel mode for each interface to **active** or **passive**. You can configure either channel mode for individual links in the LACP channel group when you are adding the links to the channel group.



**Note**

You must enable LACP globally before you can configure an interface in either the **active** or **passive** channel mode.

Table 5-1 describes the channel modes.

***Send document comments to [nexus7k-docfeedback@cisco.com](mailto:nexus7k-docfeedback@cisco.com)***

**Table 5-1 Channel Modes for Individual Links in a Port Channel**

Channel Mode	Description
<b>passive</b>	LACP mode that places a port into a passive negotiating state in which the port responds to LACP packets that it receives but does not initiate LACP negotiation.
<b>active</b>	LACP mode that places a port into an active negotiating state in which the port initiates negotiations with other ports by sending LACP packets.
<b>on</b>	All static port channels (that are not running LACP) remain in this mode. If you attempt to change the channel mode to active or passive before enabling LACP, the device returns an error message. You enable LACP on each channel by configuring the interface in that channel for the channel mode as either <b>active</b> or <b>passive</b> . When an LACP attempts to negotiate with an interface in the <b>on</b> state, it does not receive any LACP packets and becomes an individual link with that interface; it does not join the LACP channel group. The default port-channel mode is <b>on</b> .

Both the passive and active modes allow LACP to negotiate between ports to determine if they can form a port channel, based on criteria such as the port speed and the trunking state. The passive mode is useful when you do not know whether the remote system, or partner, supports LACP.

Ports can form an LACP port channel when they are in different LACP modes if the modes are compatible as in the following examples:

- A port in **active** mode can form a port channel successfully with another port that is in **active** mode.
- A port in **active** mode can form a port channel with another port in **passive** mode.
- A port in **passive** mode cannot form a port channel with another port that is also in **passive** mode, because neither port will initiate negotiation.
- A port in **on** mode is not running LACP and cannot form a port channel with another port that is in **active** or **passive** mode.

## LACP ID Parameters

This section describes the LACP parameters in the following topics:

- [LACP System Priority, page 5-9](#)
- [LACP Port Priority, page 5-10](#)
- [LACP Administrative Key, page 5-10](#)

### LACP System Priority

Each system that runs LACP has an LACP system priority value. You can accept the default value of 32768 for this parameter, or you can configure a value between 1 and 65535. LACP uses the system priority with the MAC address to form the system ID and also uses the system priority during negotiation with other devices. A higher system priority value means a lower priority.

The system ID is different for each VDC.



#### Note

The LACP system ID is the combination of the LACP system priority value and the MAC address.

***Send document comments to [nexus7k-docfeedback@cisco.com](mailto:nexus7k-docfeedback@cisco.com)***

## LACP Port Priority

Each port that is configured to use LACP has an LACP port priority. You can accept the default value of 32768 for the LACP port priority, or you can configure a value between 1 and 65535. LACP uses the port priority with the port number to form the port identifier.

LACP uses the port priority to decide which ports should be put in standby mode when there is a limitation that prevents all compatible ports from aggregating and which ports should be put into active mode. A higher port priority value means a lower priority for LACP. You can configure the port priority so that specified ports have a lower priority for LACP and are most likely to be chosen as active links, rather than hot-standby links.

## LACP Administrative Key

LACP automatically configures an administrative key value equal to the channel-group number on each port configured to use LACP. The administrative key defines the ability of a port to aggregate with other ports. A port's ability to aggregate with other ports is determined by these factors:

- Port physical characteristics, such as the data rate and the duplex capability
- Configuration restrictions that you establish

## LACP Marker Responders

You can dynamically redistribute the data traffic by using port channels. This redistribution may result from a removed or added link or a change in the load-balancing scheme. Traffic redistribution that occurs in the middle of a traffic flow can cause misordered frames.

LACP uses the Marker Protocol to ensure that frames are not duplicated or reordered due to this redistribution. The Marker Protocol detects when all the frames of a given traffic flow are successfully received at the remote end. LACP sends Marker PDUs on each of the port-channel links. The remote system responds to the Marker PDU once it receives all the frames received on this link prior to the Marker PDU. The remote system then sends a Marker Responder. Once the Marker Responders are received by the local system on all member links of the port channel, the local system can redistribute the frames in the traffic flow with no chance of misordering. The software supports only Marker Responders.

## LACP-Enabled and Static Port Channels Differences

Table 5-2 summarizes the major differences between port channels with LACP enabled and static port channels.

**Table 5-2** *Port Channels with LACP Enabled and Static Port Channels*

Configurations	Port Channels with LACP Enabled	Static Port Channels
Protocol applied	Enable globally	Not applicable
Channel mode of links	Can be either: <ul style="list-style-type: none"> <li>• Active</li> <li>• Passive</li> </ul>	Can only be On
Maximum number of links in channel	16	8

[Send document comments to nexus7k-docfeedback@cisco.com](mailto:nexus7k-docfeedback@cisco.com)

## Virtualization Support

You must configure the member ports and other port channel-related configuration from the virtual device context (VDC) that contains the port channel and member ports. You can configure up to 192 port channels across all VDCs. You can use the numbers from 1 to 4096 in each VDC to number the port channels and you can reuse these port channel numbers in different VDCs. For example, you can configure port channel 100 in VDC1 and also configure a different port channel 100 in VDC2.

However, the LACP system ID is different for each VDC. For more information on LACP, see the [“LACP Overview” section on page 5-7](#).

**Note**

---

See the *Cisco Nexus 7000 Series NX-OS Virtual Device Context Configuration Guide, Release 4.0* for complete information on VDCs and assigning resources.

---

All ports and VLANs in one port channel must be in the same VDC. When you are using LACP, all possible eight active ports and all the possible eight standby ports must be in the same VDC. Because port channels are created globally, you need to be aware of which member ports are assigned to each VDC before you configure the member port in a port channel. The port channels can originate in one VDC (with all ports in that channel in the same VDC) and partner with a port channel in another VDC (again, all ports in that channel must be in that VDC).

**Note**

---

The port-channeling load-balancing mode works either for a single module or across the entire device. You must configure load balancing using port channels in the default VDC. You cannot configure load balancing using port channels within specified VDCs. See the [“Load Balancing Using Port Channels” section on page 5-6](#) for more information on load balancing.

---

## High Availability

Port channels provide high availability by load balancing traffic across multiple ports. If a physical port fails, the port channel is still operational if there is an active member in the port channel. You can bundle ports from different modules and create a port channel that remains operational even if a module fails if the settings are common across the module.

Port channels support stateful and stateless restarts. A stateful restart occurs on a supervisor switchover. After the switchover, the Cisco NX-OS applies the runtime configuration after the switchover.

**Note**

---

See the *Cisco Nexus 7000 Series NX-OS High Availability and Redundancy Guide, Release 4.0* for complete information on high-availability features.

---

## Licensing Requirements for Port Channeling

The following table shows the licensing requirements for this feature:

***Send document comments to [nexus7k-docfeedback@cisco.com](mailto:nexus7k-docfeedback@cisco.com)***

Product	License Requirement
NX-OS	Port channeling requires no license. Any feature not included in a license package is bundled with the Cisco NX-OS system images and is provided at no extra charge to you. For a complete explanation of the NX-OS licensing scheme, see the <i>Cisco Nexus 7000 Series NX-OS Licensing Guide, Release 4.0</i> .

However, using VDCs requires an Advanced Services license.

## Prerequisites for Port Channeling

Port channeling has the following prerequisites:

- You must be logged onto the device.
- If necessary, install the Advanced Services license and enter the desired VDC.
- All ports in the channel group must be in the same VDC.
- All ports for a single port channel must be either Layer 2 or Layer 3 ports.
- All ports for a single port channel must meet the compatibility requirements. See the [“Compatibility Requirements” section on page 5-4](#) for more information on the compatibility requirements.
- You must configure load balancing from the default VDC.

## Guidelines and Limitations

Port channeling has the following guidelines and restrictions:

- You can configure up to 192 port channels across all VDCs.
- You must enable LACP before you can use that feature.
- You can configure multiple port channels on a device.
- All Ethernet ports on all modules, including those ports on a redundant supervisor engine, support port channels (with a maximum of eight active ports) with no requirement that the ports be physically contiguous or on the same module.
- Do not put shared and dedicated ports into the same port channel. (See [Chapter 2, “Configuring Basic Interface Parameters”](#) for information on shared and dedicated ports.)
- For Layer 2 port channels, ports with different STP port path costs can form a port channel if they are compatibly configured with each other.
- In STP, the port-channel bundle is considered as a single port. The port cost is the aggregation of all the configured port costs that are assigned to that channel.
- After you configure a port channel, the configuration that you apply to the port-channel interface affects the port-channel member ports. The configuration that you apply to the member ports affects only the member port where you apply the configuration.
- LACP does not support half-duplex mode. Half-duplex ports in an LACP port channels are put in the suspended state.
- You must remove the port-security information from a port before you can add that port to a port channel. Similarly, you cannot apply the port-security configuration to a port that is a member of a channel group.

***Send document comments to [nexus7k-docfeedback@cisco.com](mailto:nexus7k-docfeedback@cisco.com)***

- Do not configure ports that belong to a port channel group as private VLAN ports. While a port is part of the private VLAN configuration, the port channel configuration becomes inactive.
- Channel member ports cannot be a source or destination SPAN port.

## Configuring Port Channels

This section includes the following topics:

- [Creating a Port Channel, page 5-13](#)
- [Adding a Layer 2 Port to a Port Channel, page 5-14](#)
- [Adding a Layer 3 Port to a Port Channel, page 5-16](#)
- [Configuring the Bandwidth and Delay for Informational Purposes, page 5-18](#)
- [Shutting Down and Restarting the Port-Channel Interface, page 5-19](#)
- [Configuring a Port-Channel Description, page 5-21](#)
- [Configuring the Speed and Duplex Settings for a Port-Channel Interface, page 5-22](#)
- [Configuring Flow Control, page 5-23](#)
- [Configuring Load Balancing Using Port Channels, page 5-24](#)
- [Enabling LACP, page 5-26](#)
- [Configuring LACP Port-Channel Port Modes, page 5-27](#)
- [Configuring the LACP System Priority, page 5-28](#)
- [Configuring the LACP Port Priority, page 5-29](#)



### Note

See [Chapter 2, “Configuring Basic Interface Parameters”](#) for information on configuring the MTU for the port-channel interface. See [Chapter 4, “Configuring Layer 3 Interfaces”](#) for information on configuring IPv4 and IPv6 addresses on the port-channel interface.



### Note

If you are familiar with the Cisco IOS CLI, be aware that the Cisco NX-OS commands for this feature might differ from the Cisco IOS commands that you would use.

## Creating a Port Channel

You can create a port channel before you create a channel group. The software automatically creates the associated channel group.

### BEFORE YOU BEGIN

Enable LACP if you want LACP-based port channels.

Ensure that you are in the correct VDC (or use the **switchto vdc** command).

### SUMMARY STEPS

1. **config t**

## Send document comments to [nexus7k-docfeedback@cisco.com](mailto:nexus7k-docfeedback@cisco.com)

2. `interface port-channel channel-number`
3. `show port-channel summary`
4. `copy running-config startup-config`

### DETAILED STEPS

	Command	Purpose
Step 1	<code>config t</code>  <b>Example:</b> switch# <code>config t</code> switch(config)#	Enters configuration mode.
Step 2	<code>interface port-channel <i>channel-number</i></code>  <b>Example:</b> switch(config)# <code>interface port-channel 1</code> switch(config-if)	Specifies the port-channel interface to configure, and enters the interface configuration mode. The range is from 1 to 4096. The Cisco NX-OS automatically creates the channel group if it does not already exist.
Step 3	<code>show port-channel summary</code>  <b>Example:</b> switch(config-router)# <code>show port-channel summary</code>	(Optional) Displays information about the port channel.
Step 4	<code>copy running-config startup-config</code>  <b>Example:</b> switch(config)# <code>copy running-config startup-config</code>	(Optional) Copies the running configuration to the startup configuration.

To remove the port channel and delete the associated channel group, perform the following task.

Command	Purpose
<code>no interface port-channel <i>channel-number</i></code>  <b>Example:</b> switch(config)# <code>no interface port-channel 1</code>	Removes the port channel and deletes the associated channel group.

This example shows how to create a port channel:

```
switch# config t
switch (config)# interface port-channel 1
```

See the “[Compatibility Requirements](#)” section on page 5-4 for details on how the interface configuration changes when you delete the port channel.

## Adding a Layer 2 Port to a Port Channel

You can add a Layer 2 port to a new channel group or to a channel group that already contains Layer 2 ports. The software creates the port channel associated with this channel group if the port channel does not already exist.

***Send document comments to [nexus7k-docfeedback@cisco.com](mailto:nexus7k-docfeedback@cisco.com)***

## BEFORE YOU BEGIN

Before you begin, ensure the following:

- Enable LACP if you want LACP-based port channels.
- Ensure that you are in the correct VDC (or use the **switchto vdc** command).
- All Layer 2 member ports must run in full-duplex mode and at the same speed.

## SUMMARY STEPS

1. **config t**
2. **interface** *type slot/port*
3. **switchport**
4. **switchport mode trunk**
5. **switchport trunk** {**allowed vlan** *vlan-id* | **native** *vlan-id*}
6. **channel-group** *channel-number* [**force**] [**mode** {**on** | **active** | **passive**}]
7. **show interface** *type slot/port*
8. **copy running-config startup-config**

## DETAILED STEPS

	Command	Purpose
Step 1	<b>config t</b>  <b>Example:</b> switch# config t switch(config)#	Enters configuration mode.
Step 2	<b>interface</b> <i>type slot/port</i>  <b>Example:</b> switch(config)# interface ethernet 1/4 switch(config-if)	Specifies the interface that you want to add to a channel group and enters the interface configuration mode.
Step 3	<b>switchport</b>  <b>Example:</b> switch(config-if)# switchport	Configures the interface as a Layer 2 access port.
Step 4	<b>switchport mode trunk</b>  <b>Example:</b> switch(config-if)# switchport mode trunk	(Optional) Configures the interface as a Layer 2 trunk port.
Step 5	<b>switchport trunk</b> { <b>allowed vlan</b> <i>vlan-id</i>   <b>native</b> <i>vlan-id</i> }	(Optional) Configures necessary parameters for a Layer 2 trunk port.
	<b>Example:</b> switch(config-if)# switchport trunk native 3	

**Send document comments to [nexus7k-docfeedback@cisco.com](mailto:nexus7k-docfeedback@cisco.com)**

	Command	Purpose
Step 6	<pre>channel-group channel-number [force] [mode {on   active   passive}]</pre> <p><b>Example:</b> switch(config-if)# channel-group 5</p>	Configures the port in a channel group and sets the mode. The channel-number range is from 1 to 4096. The creates the port channel associated with this channel group if the port channel does not already exist. All static port channel interfaces are set to mode <b>on</b> ; and you set all LACP-enabled port channel interfaces to <b>active</b> or <b>passive</b> . The default mode is <b>on</b> .
	<p><b>Example:</b> switch(config-if)# channel-group 5 force</p>	(Optional) Forces an interface with some incompatible configurations to join the channel. The forced interface must have the same speed, duplex, and flow control settings as the channel group.
Step 7	<pre>show interface type slot/port</pre> <p><b>Example:</b> switch(config-router)# show interface port channel 5</p>	(Optional) Displays interface information.
Step 8	<pre>copy running-config startup-config</pre> <p><b>Example:</b> switch(config)# copy running-config startup-config</p>	(Optional) Copies the running configuration to the startup configuration.

To remove the port from the channel group, perform this task. The port reverts to its original configuration.

Command	Purpose
<pre>no channel-group</pre> <p><b>Example:</b> switch(config)# no channel-group</p>	Removes the port from the channel group.

This example shows how to add a Layer 2 Ethernet interface 1/4 to channel group 5:

```
switch# config t
switch (config)# interface ethernet 1/4
switch(config-if)# switchport
switch(config-if)# channel-group 5
```

## Adding a Layer 3 Port to a Port Channel

You can add a Layer 3 port to anew channel group or to a channel group that is already configured with Layer 3 ports. The software creates the port channel associated with this channel group if the port channel does not already exist.

If the Layer 3 port that you are adding has a configured IP address, the system removes that IP address before adding the port to the port channel. After you create a Layer 3 port channel, you can assign an IP address to the port-channel interface. You can also add subinterfaces to an existing Layer 3 port channel.

### BEFORE YOU BEGIN

Before you begin, ensure the following:

## Send document comments to [nexus7k-docfeedback@cisco.com](mailto:nexus7k-docfeedback@cisco.com)

- Enable LACP if you want LACP-based port channels.
- Ensure that you are in the correct VDC (or use the **switchto vdc** command).
- Remove any IP addresses configured on the Layer 3 interface.

### SUMMARY STEPS

1. **config t**
2. **interface** *type slot/port*
3. **no switchport**
4. **channel-group** *channel-number* [**force**] [**mode** {**on** | **active** | **passive**}]
5. **show interface** *type slot/port*
6. **copy running-config startup-config**

### DETAILED STEPS

	Command	Purpose
Step 1	<b>config t</b>  <b>Example:</b> switch# config t switch(config)#	Enters configuration mode.
Step 2	<b>interface</b> <i>type slot/port</i>  <b>Example:</b> switch(config)# interface ethernet 1/4 switch(config-if)	Specifies the interface that you want to add to a channel group and enters the interface configuration mode.
Step 3	<b>no switchport</b>  <b>Example:</b> switch(config-if)# no switchport	Configures the interface as a Layer 3 port.
Step 4	<b>channel-group</b> <i>channel-number</i> [ <b>force</b> ] [ <b>mode</b> { <b>on</b>   <b>active</b>   <b>passive</b> }]  <b>Example:</b> switch(config-if)# channel-group 5	Configures the port in a channel group and sets the mode. The channel-number range is from 1 to 4096. The Cisco NX-OS creates the port channel associated with this channel group if the port channel does not already exist.
	<b>Example:</b> switch(config-if)# channel-group 5 force	(Optional) Forces an interface with some incompatible configurations to join the channel. The forced interface must have the same speed, duplex, and flow control settings as the channel group.
Step 5	<b>show interface</b> <i>type slot/port</i>  <b>Example:</b> switch(config-router)# show interface ethernet 1/4	(Optional) Displays interface information.
Step 6	<b>copy running-config startup-config</b>  <b>Example:</b> switch(config)# copy running-config startup-config	(Optional) Copies the running configuration to the startup configuration.

## Send document comments to [nexus7k-docfeedback@cisco.com](mailto:nexus7k-docfeedback@cisco.com)

To remove the port from the channel group, perform the following task. The port reverts to its original configuration. You must reconfigure the IP addresses for this port.

Command	Purpose
<b>no channel-group</b>	Removes the port from the channel group.
<b>Example:</b> switch(config)# no channel-group	

This example shows how to add a Layer 3 Ethernet interface 1/5 to channel group 6 in on mode:

```
switch# config t
switch (config)# interface ethernet 1/5
switch(config-if)# no switchport
switch(config-if)# channel-group 6
```

This example shows how to create a Layer 3 port-channel interface and assign the IP address:

```
switch# config t
switch(config)# interface port-channel 4
switch(config-if)# ip address 192.0.2.1/8
```

## Configuring the Bandwidth and Delay for Informational Purposes

The bandwidth of the port channel is determined by the number of total active links in the channel. You configure the bandwidth and delay on port-channel interfaces for informational purposes.

### SUMMARY STEPS

1. **config t**
2. **interface port-channel** *channel-number*
3. **bandwidth** *value*
4. **delay** *value*
5. **exit**
6. **show interface port-channel** *channel-number*
7. **copy running-config startup-config**

***Send document comments to [nexus7k-docfeedback@cisco.com](mailto:nexus7k-docfeedback@cisco.com)***

## DETAILED STEPS

	Command	Purpose
Step 1	<b>config t</b>  <b>Example:</b> switch# config t switch(config)#	Enters configuration mode.
Step 2	<b>interface port-channel</b> <i>channel-number</i>  <b>Example:</b> switch(config)# interface port-channel 2 switch(config-if)#	Specifies the port-channel interface that you want to configure and enters the interface mode.
Step 3	<b>bandwidth</b> <i>value</i>  <b>Example:</b> switch(config-if)# bandwidth 60000000 switch(config-if)#	Specifies the bandwidth, which is used for informational purposes. The range is from 1 to 80,000,000 kbs. The default value depends on the total active interfaces in the channel group.
Step 4	<b>delay</b> <i>value</i>  <b>Example:</b> switch(config-if)# delay 10000 switch(config-if)#	Specifies the throughput delay, which is used for informational purposes. The range is from 1 to 16,777,215 tens of microseconds. The default value is 1.
Step 5	<b>exit</b>  <b>Example:</b> switch(config-if)# exit switch(config)#	Exits the interface mode and returns to the configuration mode.
Step 6	<b>show interface port-channel</b> <i>channel-number</i>  <b>Example:</b> switch(config-router)# show interface port-channel 2	(Optional) Displays interface information for the specified port channel.
Step 7	<b>copy running-config startup-config</b>  <b>Example:</b> switch(config)# copy running-config startup-config	(Optional) Copies the running configuration to the startup configuration.

This example shows how to configure the informational parameters of the bandwidth and delay for port channel 5:

```
switch# config t
switch (config)# interface port-channel 5
switch(config-if)# bandwidth 60000000
switch(config-if)# delay 10000
switch(config-if)#
```

## Shutting Down and Restarting the Port-Channel Interface

You can shut down and restart the port-channel interface. When you shut down a port-channel interface, no traffic passes and the interface is administratively down.

***Send document comments to [nexus7k-docfeedback@cisco.com](mailto:nexus7k-docfeedback@cisco.com)***

## SUMMARY STEPS

1. **config t**
2. **interface port-channel** *channel-number*
3. **shutdown** | **no shutdown**
4. **exit**
5. **show interface port-channel** *channel-number*
6. **copy running-config startup-config**

## DETAILED STEPS

	Command	Purpose
Step 1	<b>config t</b>  <b>Example:</b> switch# config t switch(config)#	Enters configuration mode.
Step 2	<b>interface port-channel</b> <i>channel-number</i>  <b>Example:</b> switch(config)# interface port-channel 2 switch(config-if)	Specifies the port-channel interface that you want to configure and enters the interface mode.
Step 3	<b>shutdown</b>  <b>Example:</b> switch(config-if)# shutdown switch(config-if)#	Shuts down the interface. No traffic passes and the interface displays as administratively down. The default is no shutdown.
	<b>no shutdown</b>  <b>Example:</b> switch(config-if)# no shutdown switch(config-if)#	Opens the interface. The interface displays as administratively up. If there are no operational problems, traffic passes. The default is no shutdown.
Step 4	<b>exit</b>  <b>Example:</b> switch(config-if)# exit switch(config)#	Exits the interface mode and returns to the configuration mode.
Step 5	<b>show interface port-channel</b> <i>channel-number</i>  <b>Example:</b> switch(config-router)# show interface port-channel 2	(Optional) Displays interface information for the specified port channel.
Step 6	<b>copy running-config startup-config</b>  <b>Example:</b> switch(config)# copy running-config startup-config	(Optional) Copies the running configuration to the startup configuration.

This example shows how to bring up the interface for port channel 2:

```
switch# config t
switch (config)# interface port-channel 2
switch(config-if)# no shutdown
```

[Send document comments to nexus7k-docfeedback@cisco.com](mailto:nexus7k-docfeedback@cisco.com)

## Configuring a Port-Channel Description

You can configure a description for a port channel.

### SUMMARY STEPS

1. `config t`
2. `interface port-channel channel-number`
3. `description`
4. `exit`
5. `show interface port-channel channel-number`
6. `copy running-config startup-config`

### DETAILED STEPS

	Command	Purpose
Step 1	<code>config t</code>  <b>Example:</b> switch# <code>config t</code> switch(config)#	Enters configuration mode.
Step 2	<code>interface port-channel <i>channel-number</i></code>  <b>Example:</b> switch(config)# <code>interface port-channel 2</code> switch(config-if)	Specifies the port-channel interface that you want to configure and enters the interface mode.
Step 3	<code>description</code>  <b>Example:</b> switch(config-if)# <code>description</code> engineering switch(config-if)#	Allows you to add a description to the port-channel interface. You can use up to 80 characters in the description. By default, the description does not display; you must configure this parameter before the description displays in the output.
Step 4	<code>exit</code>  <b>Example:</b> switch(config-if)# <code>exit</code> switch(config)#	Exits the interface mode and returns to the configuration mode.
Step 5	<code>show interface port-channel <i>channel-number</i></code>  <b>Example:</b> switch(config-router)# <code>show interface</code> port-channel 2	(Optional) Displays interface information for the specified port channel.
Step 6	<code>copy running-config startup-config</code>  <b>Example:</b> switch(config)# <code>copy running-config</code> startup-config	(Optional) Copies the running configuration to the startup configuration.

This example shows how to add a description to port channel 2:

```
switch# config t
switch (config)# interface port-channel 2
```

***Send document comments to [nexus7k-docfeedback@cisco.com](mailto:nexus7k-docfeedback@cisco.com)***

```
switch(config-if)# description engineering
```

## Configuring the Speed and Duplex Settings for a Port-Channel Interface

You can configure the speed and duplex settings for a port-channel interface.

### SUMMARY STEPS

1. **config t**
2. **interface port-channel** *channel-number*
3. **speed** {10 | 100 | 1000 | auto}
4. **duplex** {auto | full | half}
5. **exit**
6. **show interface port-channel** *channel-number*
7. **copy running-config startup-config**

### DETAILED STEPS

	Command	Purpose
Step 1	<b>config t</b>  <b>Example:</b> switch# config t switch(config)#	Enters configuration mode.
Step 2	<b>interface port-channel</b> <i>channel-number</i>  <b>Example:</b> switch(config)# interface port-channel 2 switch(config-if)	Specifies the port-channel interface that you want to configure and enters the interface mode.
Step 3	<b>speed</b> {10   100   1000   auto}  <b>Example:</b> switch(config-if)# speed auto switch(config-if)#	Sets the speed for the port-channel interface. The default is auto for autonegotiation.
Step 4	<b>duplex</b> {auto   full   half}  <b>Example:</b> switch(config-if)# speed auto switch(config-if)#	Sets the duplex for the port-channel interface. The default is auto for autonegotiation.
Step 5	<b>exit</b>  <b>Example:</b> switch(config-if)# exit switch(config)#	Exits the interface mode and returns to the configuration mode.

**Send document comments to [nexus7k-docfeedback@cisco.com](mailto:nexus7k-docfeedback@cisco.com)**

	Command	Purpose
Step 6	<pre>show interface port-channel channel-number</pre> <p><b>Example:</b> switch(config-router)# show interface port-channel 2 </p>	(Optional) Displays interface information for the specified port channel.
Step 7	<pre>copy running-config startup-config</pre> <p><b>Example:</b> switch(config)# copy running-config startup-config </p>	(Optional) Copies the running configuration to the startup configuration.

This example shows how to set port channel 2 to 100 Mbps:

```
switch# config t
switch (config)# interface port channel 2
switch(config-if)# speed 100
```

## Configuring Flow Control

You can enable or disable the capability of the port-channel interfaces that run at 1 Gb or higher to send or receive flow-control pause packets. For port-channels interfaces that run at lower speeds, you can enable or disable only the capability of the port-channel interfaces to receive pause packets.



### Note

The setting has to match at both the local and remote ends of the link for the flow control to work properly.

### SUMMARY STEPS

1. **config t**
2. **interface port-channel** *channel-number*
3. **flowcontrol** {receive | send} {desired | off | on}
4. **exit**
5. **show interface port-channel** *channel-number*
6. **copy running-config startup-config**

***Send document comments to [nexus7k-docfeedback@cisco.com](mailto:nexus7k-docfeedback@cisco.com)***

## DETAILED STEPS

	Command	Purpose
Step 1	<b>config t</b>  <b>Example:</b> switch# config t switch(config)#	Enters configuration mode.
Step 2	<b>interface port-channel</b> <i>channel-number</i>  <b>Example:</b> switch(config)# interface port-channel 2 switch(config-if)	Specifies the port-channel interface that you want to configure and enters the interface mode.
Step 3	<b>flowcontrol</b> {receive   send} {desired   off   on}  <b>Example:</b> switch(config-if)# flowcontrol send desired switch(config-if)#	Sets the flow control parameters for sending and receiving the pause packets for the port-channel interface. The default is desired.
Step 4	<b>exit</b>  <b>Example:</b> switch(config-if)# exit switch(config)#	Exits the interface mode and returns to the configuration mode.
Step 5	<b>show interface port-channel</b> <i>channel-number</i>  <b>Example:</b> switch(config-router)# show interface port-channel 2	(Optional) Displays interface information for the specified port channel.
Step 6	<b>copy running-config startup-config</b>  <b>Example:</b> switch(config)# copy running-config startup-config	(Optional) Copies the running configuration to the startup configuration.

This example shows how to configure the port-channel interface for port channel group 2 to send and receive pause packets:

```
switch# config t
switch (config)# interface port channel 2
switch(config-if)# flowcontrol receive on
switch(config-if)# flowcontrol send on
```

## Configuring Load Balancing Using Port Channels

You can configure the load-balancing algorithm for port channels that applies to the entire device or to only one module regardless of the VDC association. Module-based load balancing takes precedence over device-based load balancing.

### BEFORE YOU BEGIN

Before you begin, ensure the following:

## Send document comments to [nexus7k-docfeedback@cisco.com](mailto:nexus7k-docfeedback@cisco.com)

- Enable LACP if you want LACP-based port channels.
- Ensure that you are in the correct VDC (or use the `switchto vdc` command).

### SUMMARY STEPS

1. `config t`
2. `port-channel load-balance ethernet {destination-ip | destination-mac | destination-port | source-destination-ip | source-destination-mac | source-destination-port | source-ip | source-mac | source-port} [module-number]`
3. `show port-channel load-balance`
4. `copy running-config startup-config`

### DETAILED STEPS

	Command	Purpose
Step 1	<b>config t</b>  <b>Example:</b> switch# config t switch(config)#	Enters configuration mode.
Step 2	<b>port-channel load-balance ethernet</b> <b>{destination-ip   destination-mac   destination-port   source-destination-ip   source-destination-mac   source-destination-port   source-ip   source-mac   source-port}</b> <b>[module-number]</b>  <b>Example:</b> switch(config)# port-channel load-balance ethernet source-destination-mac switch(config)#	Specifies the load-balancing algorithm for the device or module. The range depends on the device. The default for Layer 3 is <b>source-destination-ip</b> for both IPv4 and IPv6, and the default for non-IP is <b>source-destination-mac</b> .
Step 3	<b>show port-channel load-balance</b>  <b>Example:</b> switch(config-router)# show port-channel load-balance	(Optional) Displays the port-channel load-balancing algorithm.
Step 4	<b>copy running-config startup-config</b>  <b>Example:</b> switch(config)# copy running-config startup-config	(Optional) Copies the running configuration to the startup configuration.

To restore the default load-balancing algorithm of source-destination-mac for non-IP traffic and source-destination-ip for IP traffic, perform the following task.

***Send document comments to [nexus7k-docfeedback@cisco.com](mailto:nexus7k-docfeedback@cisco.com)***

Command	Purpose
<b>no port-channel load-balance ethernet</b>  <b>Example:</b> switch(config)# no port-channel load-balance ethernet	Restores the default load-balancing algorithm.

This example shows how to configure source IP load balancing for port channels on module 5:

```
switch# config t
switch (config)# port-channel load-balance ethernet source-ip module 5
```

## Enabling LACP

LACP is disabled by default; you must enable LACP before you begin LACP configuration. You cannot disable LACP while any LACP configuration is present.

LACP learns the capabilities of LAN port groups dynamically and informs the other LAN ports. Once LACP identifies correctly matched Ethernet links, it group the links into a port channel. The port channel is then added to the spanning tree as a single bridge port.

To configure LACP, you must do the following:

- Enable LACP globally by using the **feature lacp** command.
- You can use different modes for different interfaces within the same LACP-enabled port channel. You can change the mode between **active** and **passive** for an interface only if it is the only interface that is designated to the specified channel group.

### BEFORE YOU BEGIN

Ensure that you are in the correct VDC (or use the **switchto vdc** command).

### SUMMARY STEPS

1. **config t**
2. **feature lacp**
3. **copy running-config startup-config**

### DETAILED STEPS

	Command	Purpose
Step 1	<b>config t</b>  <b>Example:</b> switch# config t switch(config)#	Enters configuration mode.

**Send document comments to [nexus7k-docfeedback@cisco.com](mailto:nexus7k-docfeedback@cisco.com)**

	Command	Purpose
Step 2	<b>feature lacp</b>  <b>Example:</b> switch(config)# feature lacp	Enables LACP on the device.
Step 3	<b>copy running-config startup-config</b>  <b>Example:</b> switch(config)# copy running-config startup-config	(Optional) Copies the running configuration to the startup configuration.

This example shows how to enable LACP:

```
switch# configure terminal
switch (config)# feature lacp
```

## Configuring LACP Port-Channel Port Modes

After you enable LACP, you can configure the channel mode for each individual link in the LACP port channel as **active** or **passive**. This channel configuration mode allows the link to operate with LACP.

When you configure port channels with no associated aggregation protocol, all interfaces on both sides of the link remain in the **on** channel mode.

### BEFORE YOU BEGIN

Ensure that you are in the correct VDC (or use the **switchto vdc** command).

### SUMMARY STEPS

1. **config t**
2. **interface** *type slot/port*
3. **channel-group** *number* **mode** { **active** | **on** | **passive** }
4. **show port-channel summary**
5. **copy running-config startup-config**

### DETAILED STEPS

	Command	Purpose
Step 1	<b>config t</b>  <b>Example:</b> switch# config t switch(config)#	Enters configuration mode.
Step 2	<b>interface</b> <i>type slot/port</i>  <b>Example:</b> switch(config)# interface ethernet 1/4 switch(config-if)	Specifies the interface to configure, and enters the interface configuration mode.

**Send document comments to [nexus7k-docfeedback@cisco.com](mailto:nexus7k-docfeedback@cisco.com)**

	Command	Purpose
Step 3	<b>channel-group</b> <i>number</i> <b>mode</b> { <b>active</b>   <b>on</b>   <b>passive</b> }  <b>Example:</b> switch(config-if)# <b>channel-group</b> 5 <b>mode</b> active	Specifies the port mode for the link in a port channel. After LACP is enabled, you configure each link or the entire channel as active or passive.  When you run port channels with no associated aggregation protocol, the port-channel mode is always on.  The default port-channel mode is on.
Step 4	<b>show port-channel summary</b>  <b>Example:</b> switch(config-if)# <b>show port-channel summary</b>	(Optional) Displays summary information about the port channels
Step 5	<b>copy running-config startup-config</b>  <b>Example:</b> switch(config-if)# <b>copy running-config startup-config</b>	(Optional) Copies the running configuration to the startup configuration.

This example shows how to set the LACP-enabled interface to the active port-channel mode for Ethernet interface 1/4 in channel group 5:

```
switch# config t
switch (config)# interface ethernet 1/4
switch(config-if)# channel-group 5 mode active
```

## Configuring the LACP System Priority

The LACP system ID is the combination of the LACP system priority value and the MAC address. You can reuse the same configuration for the system priority values in more than one VDC.

### BEFORE YOU BEGIN

Enable LACP.

Ensure that you are in the correct VDC (or use the **switch tovdc** command).

### SUMMARY STEPS

1. **config t**
2. **lacp system-priority** *priority*
3. **show lacp system-identifier**
4. **copy running-config startup-config**

***Send document comments to [nexus7k-docfeedback@cisco.com](mailto:nexus7k-docfeedback@cisco.com)***

## DETAILED STEPS

	Command	Purpose
Step 1	<code>config t</code>  <b>Example:</b> switch# config t switch(config)#	Enters configuration mode.
Step 2	<code>lacp system-priority priority</code>  <b>Example:</b> switch(config)# lacp system-priority 40000	Configures the system priority for use with LACP. Valid values are 1 through 65535, and higher numbers have lower priority. The default value is 32768.  <b>Note</b> Each VDC has a different LACP system ID because the software adds the MAC address to this configured value.
Step 3	<code>show lacp system-identifier</code>  <b>Example:</b> switch(config-if)# show lacp system-identifier	Displays the LACP system identifier.
Step 4	<code>copy running-config startup-config</code>  <b>Example:</b> switch(config)# copy running-config startup-config	(Optional) Copies the running configuration to the startup configuration.

This example shows how to set the LACP system priority to 2500:

```
switch# configure terminal
switch(config)# lacp system-priority 2500
```

## Configuring the LACP Port Priority

When you enable LACP, you can configure each link in the LACP port channel for the port priority.

### BEFORE YOU BEGIN

Enable LACP.

Ensure that you are in the correct VDC (or use the **switchto vdc** command).

### SUMMARY STEPS

1. `config t`
2. `interface type slot/port`
3. `lacp port-priority priority`
4. `copy running-config startup-config`

***Send document comments to [nexus7k-docfeedback@cisco.com](mailto:nexus7k-docfeedback@cisco.com)***

## DETAILED STEPS

	Command	Purpose
Step 1	<b>config t</b>  <b>Example:</b> switch# config t switch(config)#	Enters configuration mode.
Step 2	<b>interface type slot/port</b>  <b>Example:</b> switch(config)# interface ethernet 1/4 switch(config-if)	Specifies the interface to configure, and enters the interface configuration mode.
Step 3	<b>lacp port-priority priority</b>  <b>Example:</b> switch(config-if)# lacp port-priority 40000.	Configures the port priority for use with LACP. Valid values are 1 through 65535, and higher numbers have lower priority. The default value is 32768.
Step 4	<b>copy running-config startup-config</b>  <b>Example:</b> switch(config-if)# copy running-config startup-config	(Optional) Copies the running configuration to the startup configuration.

This example shows how to set the LACP port priority for Ethernet interface 1/4 to 40000:

```
switch# config t
switch (config)# interface ethernet 1/4
switch(config-if)# lacp port priority 40000
```

[Send document comments to nexus7k-docfeedback@cisco.com](mailto:nexus7k-docfeedback@cisco.com)

## Verifying Port-Channel Configuration

To display port-channel configuration information, perform one of the following tasks:

Command	Purpose
<b>show interface port-channel</b> <i>channel-number</i>	Displays the status of a port-channel interface.
<b>show port-channel compatibility-parameters</b>	Displays the parameters that must be the same among the member ports in order to join a port channel.
<b>show port-channel database</b> [ <b>interface port-channel</b> <i>channel-number</i> ]	Displays the aggregation state for one or more port-channel interfaces.
<b>show port-channel load-balance</b>	Displays the type of load balancing in use for port channels.
<b>show port-channel summary</b>	Displays a summary for the port-channel interfaces.
<b>show port-channel traffic</b>	Displays the traffic statistics for port channels.
<b>show port-channel usage</b>	Displays the range of used and unused channel numbers.
<b>show lacp</b> { <b>counters</b> [ <b>interface port-channel</b> <i>channel-number</i> ]   [ <b>interface type/slot</b> ]   <b>neighbor</b> [ <b>interface port-channel</b> <i>channel-number</i> ]   <b>port-channel</b> [ <b>interface port-channel</b> <i>channel-number</i> ]   <b>system-identifier</b> }}	Displays information on LACP.
<b>show running-config interface port-channel</b> <i>channel-number</i>	Displays information on the running configuration of the port-channel.

For more information about the fields in the output from these commands, see the *Cisco Nexus 7000 Series NX-OS Layer 2 Switching Command Reference, Release 4.0*.

## Displaying Statistics

To display port-channel interface configuration information, perform one of the following tasks:

Command	Purpose
<b>clear counters interface port-channel</b> <i>channel-number</i>	Clears the counters.
<b>clear lacp counters</b> [ <b>interface port-channel</b> <i>channel-number</i> ]	Clears the LACP counters.
<b>show interface counters</b> [ <b>module</b> <i>module</i> ]	Displays input and output octets unicast packets, multicast packets, and broadcast packets.
<b>show interface counters detailed</b> [ <b>all</b> ]	Displays input packets, bytes, and multicast and output packets and bytes.

**Send document comments to [nexus7k-docfeedback@cisco.com](mailto:nexus7k-docfeedback@cisco.com)**

Command	Purpose
<code>show interface counters errors [module module]</code>	Displays information on the number of error packets.
<code>show lacp counters</code>	Displays statistics for LACP.

## Port Channel Example Configuration

The following example shows how to create an LACP port channel and add two Layer 2 interfaces to that port channel:

```
switch# config t
switch (config)# feature lacp
switch (config)# interface port-channel 5
switch (config-if)# interface ethernet 1/4
switch(config-if)# switchport
switch(config-if)# channel-group 5 mode active
switch(config-if)# lacp port priority 40000
switch(config-if)# interface ethernet 1/7
switch(config-if)# switchport
switch(config-if)# channel-group 5 mode
```

The following example shows how to add two Layer 3 interfaces to a channel group. The Cisco NX-OS automatically creates the port channel:

```
switch# config t
switch (config)# interface ethernet 1/5
switch(config-if)# no switchport
switch(config-if)# no ip address
switch(config-if)# channel-group 6 mode active
switch (config)# interface ethernet 2/5
switch(config-if)# no switchport
switch(config-if)# no ip address
switch(config-if)# channel-group 6 mode active
switch (config)# interface port-channel 6
switch(config-if)# ip address 192.0.2.1/8
```

## Default Settings

Table 5-3 lists the default settings for port-channel parameters.

**Table 5-3** Default Port-Channel Parameters

Parameters	Default
Port channel	Admin up
Load balancing method for Layer 3 interfaces	Source and destination IP address
Load balancing method for Layer 2 interfaces	Source and destination MAC address
Load balancing per module	Disabled
LACP	Disabled
Channel mode	on

**[Send document comments to nexus7k-docfeedback@cisco.com](mailto:nexus7k-docfeedback@cisco.com)**

**Table 5-3 Default Port-Channel Parameters (continued)**

Parameters	Default
LACP system priority	32768
LACP port priority	32768

## Additional References

For additional information related to implementing port channels, see the following sections:

- [Related Documents, page 5-33](#)
- [MIBs, page 5-34](#)

## Related Documents

Related Topic	Document Title
Configuring Layer 2 interface	<a href="#">Chapter 3, “Configuring Layer 2 Interfaces”</a>
Configuring Layer 3 interfaces	<a href="#">Chapter 4, “Configuring Layer 3 Interfaces”</a>
Shared and dedicated ports	<a href="#">Chapter 2, “Configuring Basic Interface Parameters”</a>
Command reference	<i>Cisco Nexus 7000 Series NX-OS Interfaces Command Reference, Release 4.0</i>
Interfaces	<i>Cisco DCNM Interfaces Configuration Guide</i>
System management	<i>Cisco Nexus 7000 Series NX-OS System Management Configuration Guide, Release 4.0</i>
High availability	<i>Cisco Nexus 7000 Series NX-OS High Availability and Redundancy Guide, Release 4.0</i>
VDCs	<i>Cisco Nexus 7000 Series NX-OS Virtual Device Context Configuration Guide, Release 4.0</i>
Licensing	<i>Cisco Nexus 7000 Series NX-OS Licensing Guide, Release 4.0</i>
Release Notes	<i>Cisco Nexus 7000 Series NX-OS Release Notes, Release 4.0</i>

## Standards

Standards	Title
IEEE 802.3ad	—

***Send document comments to [nexus7k-docfeedback@cisco.com](mailto:nexus7k-docfeedback@cisco.com)***

## MIBs

MIBs	MIBs Link
<ul style="list-style-type: none"><li data-bbox="110 327 496 359">• IEEE8023-LAG-CAPABILITY</li><li data-bbox="110 373 354 405">• CISCO-LAG-MIB</li></ul>	To locate and download MIBs, go to the following URL: <a href="http://www.cisco.com/public/sw-center/netmgmt/cmtk/mibs.shtml">http://www.cisco.com/public/sw-center/netmgmt/cmtk/mibs.shtml</a>