



CHAPTER 1

Overview

This chapter provides an overview of the Cisco Nexus 5000 Series switches, which include the Cisco Nexus 5000 Platform switches and the Cisco Nexus 5500 Platform switches. The overview of each of these switches includes information on the expansion modules, power supplies, and fan modules that you can include with them.

This chapter includes the following sections:

- [Cisco Nexus 5500 Platform Switches, page 1-1](#)
- [Cisco Nexus 5000 Platform Switches, page 1-29](#)

Cisco Nexus 5500 Platform Switches

The Cisco Nexus 5500 Platform supports the following application scenarios, many of which require the installation of other products:

- As an access-layer switch, it can be used purely as a 1- and 10-Gigabit Ethernet switch, consolidating 10 Gigabit Ethernet connections into a smaller number of server connections trunked to the aggregation layer.
- As a smaller-scale aggregation switch, it can be used as a Layer 3 1- and 10-Gigabit Ethernet switch, consolidating multiple 1- and 10-Gigabit Ethernet connections from a data center access layer.
- In conjunction with the Cisco Nexus 2248T GE Ethernet Fabric Extender, the Cisco Nexus 5500 Platform can be a high-density 1-Gigabit Ethernet switching system, consolidating more than 900 Gigabit Ethernet connections within a single management plane.
- In conjunction with the Cisco Nexus 2232T 10GE Fabric Extender, it can be a high-density switching system, consolidating more than 600 10-Gigabit Ethernet connections within a single management plane.
- In conjunction with the Cisco Nexus 2224TM 10GE Fabric Extender, it can be a high-density switching system, consolidating more than 600 10-Gigabit Ethernet connections within a single management plane.
- As a rack-level I/O consolidation platform, the switch carries Ethernet traffic from servers to the aggregation layer and carries FC traffic to existing Fibre Channel SANs.
- As a crucial element in data center I/O consolidation, the switch enables I/O consolidation at the access layer and provides interoperability with the Cisco Nexus 5500 Platform and other standards-based products.

This section describes the Cisco Nexus 5500 Platform switches and contains these sections:

- [Cisco Nexus 5596UP Switch, page 1-2](#)

- [Cisco Nexus 5596T Switch, page 1-12](#)
- [Cisco Nexus 5548UP and 5548P Switches, page 1-18](#)

Cisco Nexus 5596UP Switch

This section describes the Cisco Nexus 5596UP switch and its components. This section includes the following topics:

- [Features, page 1-2](#)
- [Chassis, page 1-2](#)
- [Expansion Modules, page 1-4](#)
- [Ports, page 1-7](#)
- [Power Supply, page 1-8](#)
- [Fan Module, page 1-10](#)
- [Transceivers, page 1-11](#)

Features

The Cisco Nexus 5596UP switch is a top-of-rack, 10-Gigabit Ethernet and Fibre channel over Ethernet (FCoE) switch offering up to 1920 Gigabit throughput and up to 96 ports. The switch has 48 1- and 10-Gigabit Ethernet and FCoE ports and three expansion slots. As a top-of-rack switch, all the servers in the rack connect to the Cisco Nexus 5596UP switch, and it connects to the LAN or SAN.

The Cisco Nexus 5596UP switch has the following features:

- 48 fixed 1- and 10-Gigabit Ethernet server connection ports on the back of the switch
- Three slots on the back of the switch for optional expansion modules, which can be either a 16-port 10-Gigabit generic expansion module 2 (GEM2) or a layer 3 GEM2
- Two slots on the front of the switch for hot swap-capable power supplies, which provide front-to-back airflow for cooling (the Cisco Nexus 5596T and 5596UP switches alternatively support back-to-front [port-side intake] airflow)
- Four slots on the front of the switch for hot swap-capable fan modules.
- Layer 2 or Layer 3 I/O modules
- One USB port on the front of the switch



Note

Hot swapping of normal air flow fans and power supplies with reverse airflow fans and power supplies is not supported on the Cisco Nexus 5000 switches. Hot swapping of fans and power supplies is only supported if they are replaced with the same direction parts.

Chassis

The Cisco Nexus 5596UP chassis is 2 RU or 3.47 inches (8.8 cm) tall, 17.3 inches (43.9 cm) wide, and 29.5 inches (74.9 cm) deep. It is designed to be mounted in a standard 19-inch wide rack. The front of the switch, shown in [Figure 1-1](#), has a USB port, four Ethernet and ports (two cross-connect ports, one management port, and one console port), two power supplies, and four fan modules.

Figure 1-1 Front View of the Cisco Nexus 5596UP Switch

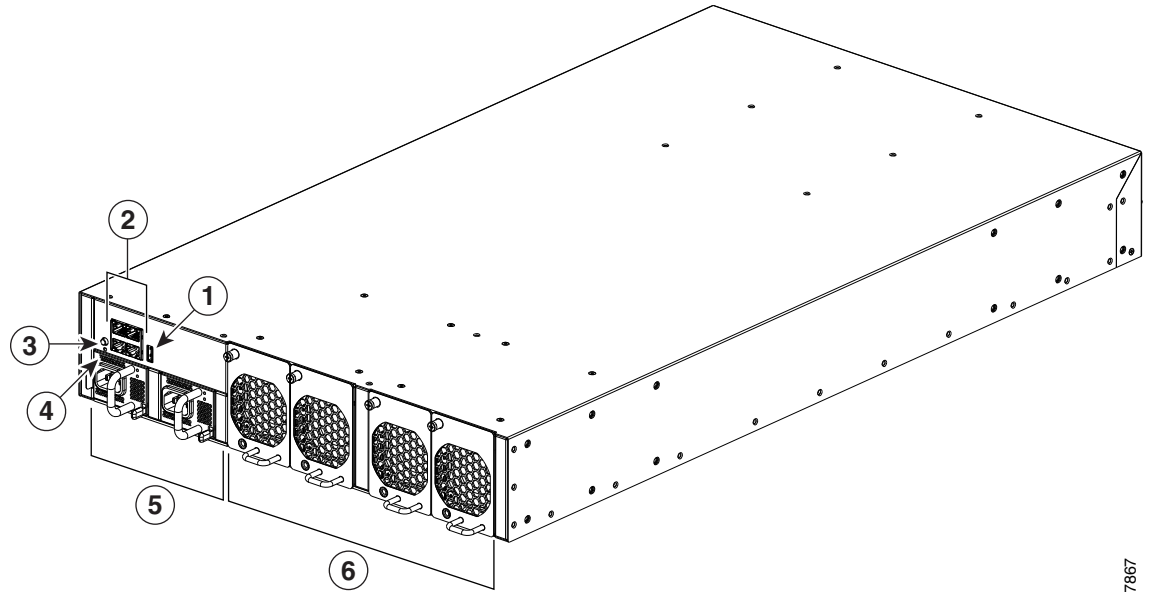

237867

1	USB port	4	System status LED
2	Management and console ports (two RJ-45 Ethernet connector ports on the left, a RJ-45 network management connector on the upper right, and a console connector on the lower right)	5	Two power supplies
3	Identifier LED	6	Four fan modules

The management and console ports are in a 2 x 2 stacked RJ-45 jack. [Figure 1-2](#) shows a close-up view of these ports. For information about the connector port LEDs, see [Table D-1 on page D-2](#).

Figure 1-2 Management and Console Ports

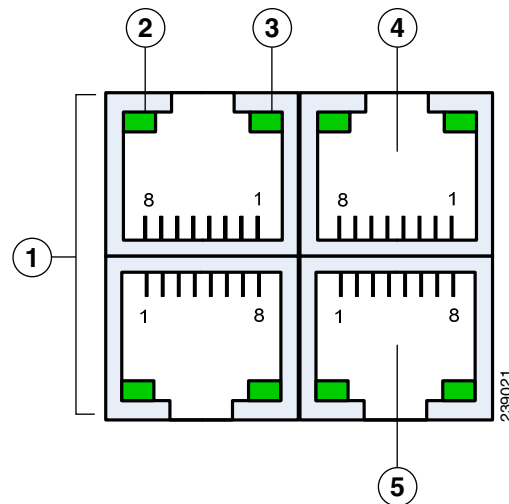

1	Internal cross-connect ports	4	Network management port
2	Link LED (left LED)	5	Console port
3	Activity LED (right LED)		

The rear of the Cisco Nexus 5596UP chassis, shown in [Figure 1-3](#), has 48 fixed 10-Gigabit Ethernet data ports on the bottom and three slots for optional expansion modules on top.

Figure 1-3 Rear View of the Cisco Nexus 5596UP Switch

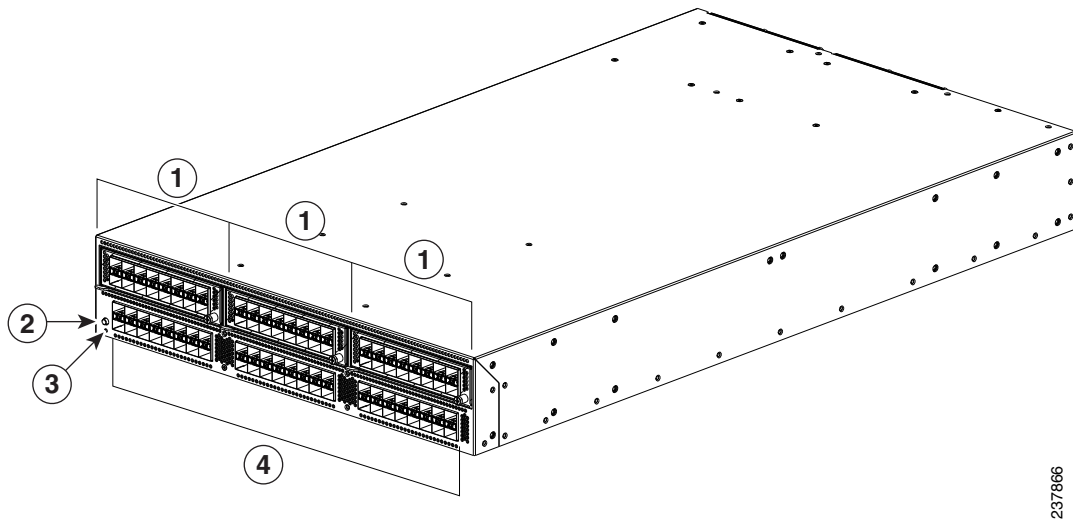

1	Expansion modules, shown here with three 16-port Universal GEM2 modules (can also have Layer 3 GEM2 modules)	3	System status LED
2	Identifier LED	4	48 fixed 1- and 10-Gigabit Ethernet ports



Note

The L1/L2/Mgmt1 ports are not usable. They are disabled at this time.

Expansion Modules

Expansion modules allow the Cisco Nexus 5596UP switch to be configured as cost-effective 10-Gigabit Ethernet switches and as I/O consolidation platforms with native Fibre Channel connectivity.

The Cisco Nexus 5596UP switch has three slots that can be used for the following optional expansion modules:

- 4-port QSFP expansion module
- 16-port Universal (Fibre Channel and Ethernet) GEM (N55-M16UP) that provides 8-, 4-, 2-, or 1-Gbps Fibre Channel and 1- or 10-Gigabit Ethernet ports

- Layer 3 GEMs (N55-M160L3 and N55-M160L3-V2) provide 160 Gbps of Layer 3 services. The N55-M160L3-V2 uses a newer version of the Layer 3 ASIC that enables higher table sizes in a future software release from 8K host entries to 16K host entries or from 4K multicast routes to 8K multicast routes (IPv4).

You can hot swap the expansion modules during operations, except the Layer 3 GEMs. You must power down the switch before you can insert or remove the Layer 3 GEMs.

This section includes the following topics:

- [4-port QSFP+ GEM, page 1-5](#)
- [16-port Universal GEM2, page 1-5](#)
- [Layer 3 GEM, page 1-6](#)

4-port QSFP+ GEM

The QSFP+ GEM (N55-M4Q), shown in [Figure 1-4](#), is a generic expansion module (GEM) that provides 16x10 Gigabit Ethernet SFP+ in a 4 x QSFP+ form factor. This module is a field-replaceable unit (FRU) that you can hot swap during operations.

Figure 1-4 4-Port QSFP+ GEM



414204

16-port Universal GEM2

The 16-port Universal GEM2, shown in [Figure 1-5](#), has 16 8-, 4-, 2-, or 1-Gbps Fibre Channel or 1- and 10-Gigabit Ethernet ports. This module is a field-replaceable unit (FRU) that you can hot swap during operations.

Figure 1-5 16-Port Universal GEM2

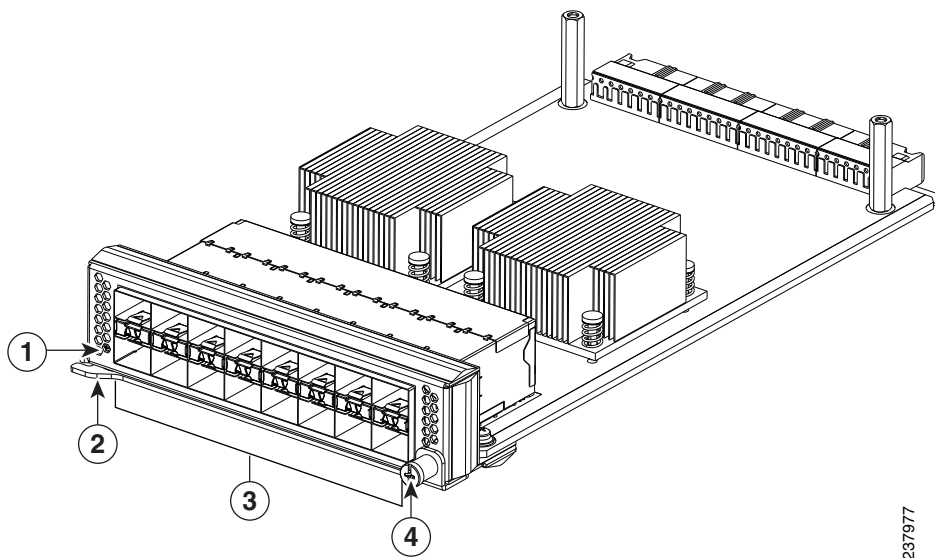

1	Status LED	3	16 ports supporting 8-, 4-, 2-, or 1-Gbps transceivers or 1- and 10-Gigabit transceivers
2	Eject lever	4	Captive screw that locks the eject lever in a closed position

See [Figure 1-7 on page 1-7](#) to see how ports are grouped and numbered on the Fibre Channel plus Ethernet expansion module.

Layer 3 GEM

The Layer 3 GEMs (N55-M160L3 and N55-M160L3-V2), shown in [Figure 1-6](#), provide 160 Gbps of Layer 3 services. The expansion modules are field-replaceable units (FRUs). The N55-M160L3-V2 uses a newer version of the Layer 3 ASIC that enables higher table sizes in a future software release from 8K host entries to 16K host entries or from 4K multicast routes to 8K multicast routes (IPv4).

The Layer 3 GEMs are not hot swappable and can be inserted and removed only when the switch is powered down.



Note

When a Layer 3 I/O module is inserted into a Cisco Nexus 5500 Series switch that does not have any other I/O modules, you cannot use port-channel numbers 127 and 128 as these port-channel numbers are used by the switch for internal communication. However, if port-channel numbers 127 and 128 have already been used before a Layer 3 I/O module is inserted into the switch, new port-channel numbers will be used by the switch for internal communication.

Figure 1-6 Layer 3 GEM2

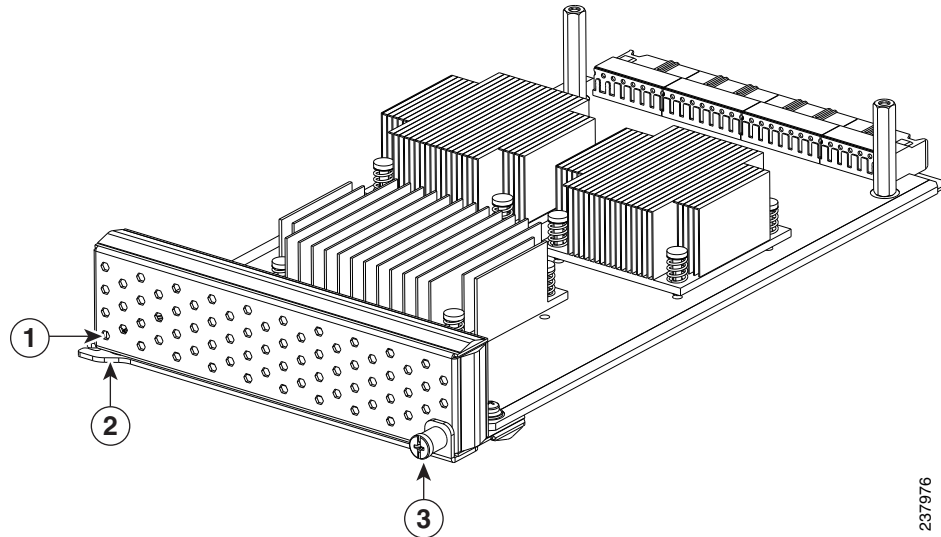

237976

1	Status LED	3	Captive screw that locks the eject lever in a closed position
2	Ejector lever		

Ports

Each port on the Cisco Nexus 5596UP switch is numbered, and groups of ports are numbered based on their function. The ports are numbered top to bottom and left to right. The 48 fixed ports support 8-, 4-, 2-, or 1-Gbps Fibre Channel transceivers and 1- or 10-Gigabit Ethernet transceivers.

Figure 1-7 shows how ports are numbered and grouped by function for both the fixed ports and the Fibre Channel plus Ethernet expansion module ports.

Figure 1-7 Port Numbering of Fixed Ports and Fibre Channel Plus Ethernet Expansion Module Ports

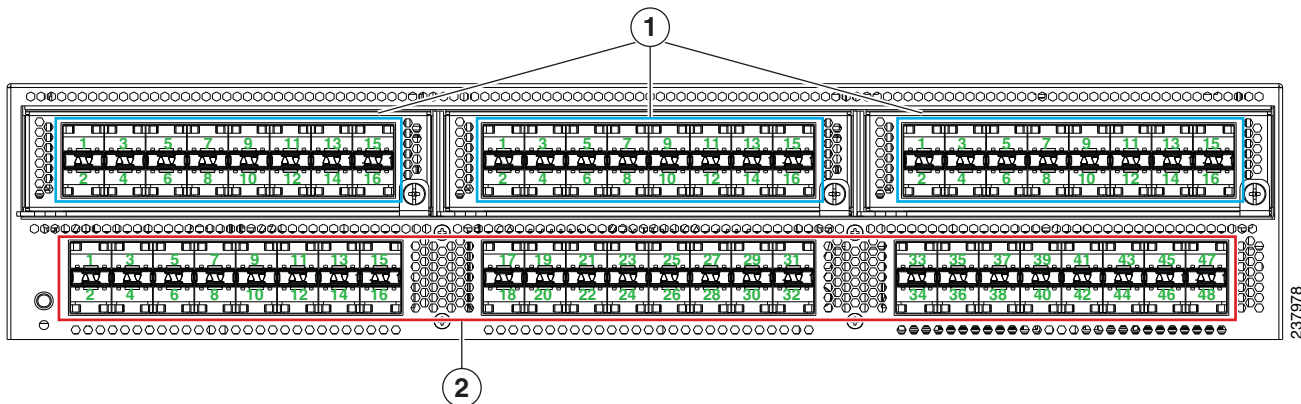

237976

1	Port numbering for the 16-port GEM	2	Port numbering for the 48 fixed ports
---	------------------------------------	---	---------------------------------------

Power Supply

The Cisco Nexus 5596UP uses a front-end power supply. The chassis has slots for two power supplies. The Cisco Nexus 5596UP switch is fully functional with one power supply, but you can include a second power supply for power redundancy.

[Table 1-1](#) lists the power supplies that you can order with the Cisco Nexus 5596UP and 5596T switches.

Table 1-1 Power Supplies for the Cisco Nexus 5596UP and 5596T switches

Part Number	Power Supply
N55-PAC-1100W	Cisco Nexus 5596UP PSU Port-Side Exhaust Airflow module, A/C, 100-240V, 1100W
N55-PAC-1100W(=)	Cisco Nexus 5596UP PSU Port-Side Exhaust Airflow module spare, A/C, 100-240V, 1100W
N55-PAC-1100W-B	Cisco Nexus 5596UP/5596T PSU Port-Side Intake Airflow module, A/C, 100-240V, 1100W
N55-PAC-1100W-B(=)	Cisco Nexus 5596UP/5596T PSU Port-Side Intake Airflow module spare, A/C, 100-240V, 1100W
N55-PDC-1100W	Cisco Nexus 5596UP/5596T PSU DC Port-Side Exhaust module, 1100 W
N55-PDC-1100W(=)	Cisco Nexus 5596UP/5596T PSU DC Port-Side Exhaust module spare, 1100 W
NXA-PHV-1100W	Cisco Nexus 5500/6000 Platinum HV-AC-DC PS, Port side Exhaust airflow, 1100W
NXA-PHV-1100W(=)	Cisco Nexus 5500/6000 Platinum HV-AC-DC PS, Port side Exhaust airflow, 1100W, spare
NXA-PHV-1100W-B	Cisco Nexus 5500/6000 Platinum HV-AC-DC PS, Port side Intake airflow, 1100W
NXA-PHV-1100W-B(=)	Cisco Nexus 5500/6000 Platinum HV-AC-DC PS, Port side Intake airflow, 1100W, spare



Note

Front to Back (FAF) Airflow and DC Power Supply is now supported for the Cisco Nexus 5596T. For details see the [Cisco Nexus 5500 Datasheet](#).

[Figure 1-8](#) shows an AC power supply. For more information on the LEDs, see [Table D-1 on page D-2](#).

Figure 1-8 AC Power Supply for the Cisco Nexus 5596UP Switch

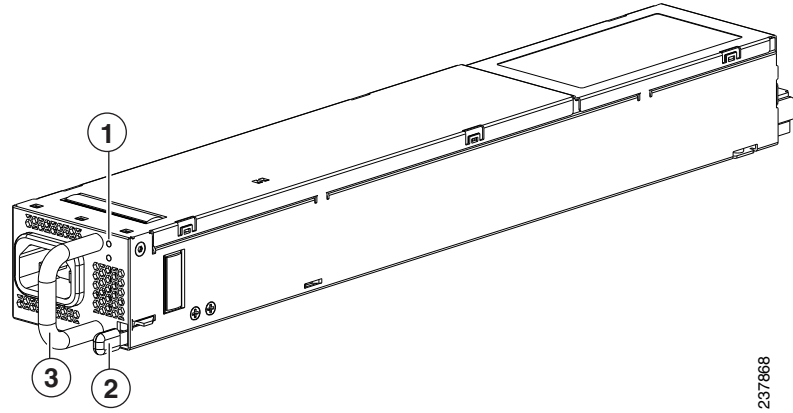

1	Failure (top) and Power (bottom) LEDs	3	Release lever
2	Handle		

Figure 1-9 shows the NXA-PAC-1100W.

Figure 1-9 NXA-PAC-1100W

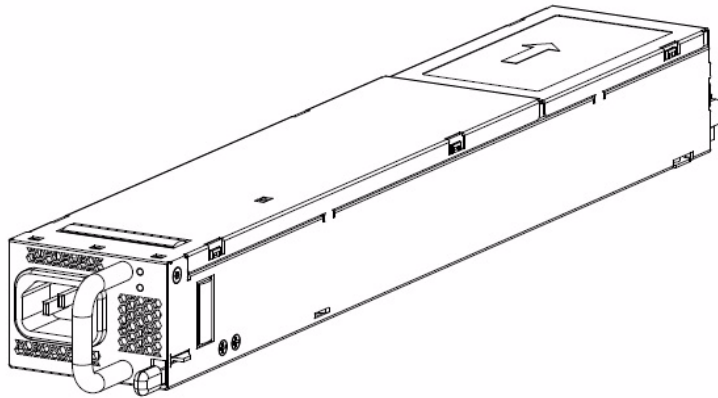
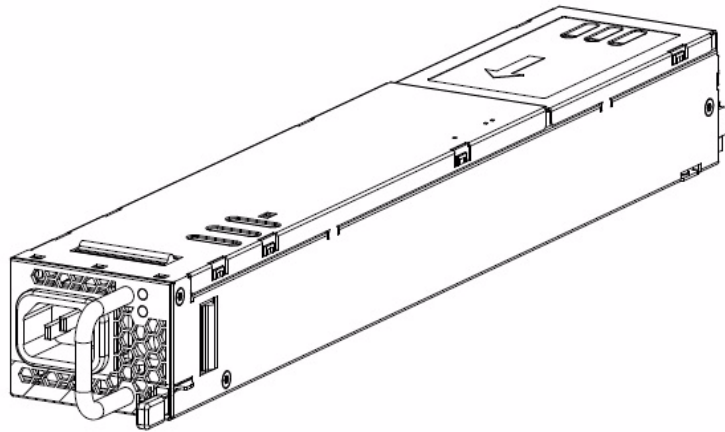

Figure 1-10 shows the NXA-PAC-1100W-B

Figure 1-10 NXA-PAC-1100W-B



[Figure 1-11](#) shows NXA-PDC-1100W

Figure 1-11 NXA-PDC-1100W

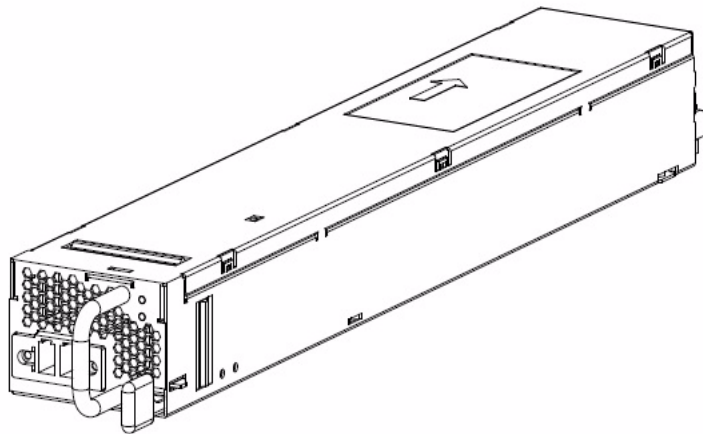

Note

Never leave a power supply slot empty. If you remove a power supply, replace it with another one. If you do not have a replacement power supply, leave the non functioning one in place until you can replace it.

Fan Module

The Cisco Nexus 5596UP switch has four fan modules. Although the switch can function when a fan stops functioning within a fan module, if a whole fan module stops functioning, you must replace the fan module. The Cisco Nexus 5596UP supports the reverse air flow fan tray (N5596UP-FAN-B).

[Figure 1-12](#) shows a fan module.

**Caution**

All of the power supply and fan modules in the same chassis must use the same airflow direction or an error will occur with possible over heating and shut down of the switch. If you power up the switch with more than one airflow direction, you must power down the switch and replace the modules with the wrong airflow direction (modules not taking in coolant air from the cold aisle) before powering up the switch.

Figure 1-12 Cisco Nexus 5596 Fan Module

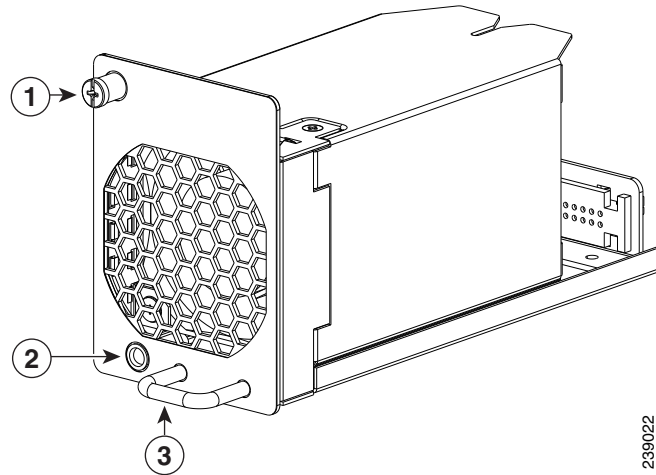

1	Captive screw	3	Handle
2	Status LED		

The bicolor status LED indicates fan tray health. Green indicates normal operation, while amber indicates a fan failure. For more information about LEDs, see [Table D-1 on page D-2](#).

Transceivers

The Cisco Nexus 5596 switch supports both SFP and SFP+ Ethernet transceivers and SFP Fibre Channel transceivers.

This section includes the following topics:

- [SFP+ Transceivers, page 1-11](#)
- [SFP+ Copper Cables, page 1-12](#)
- [SFP Fibre Channel Transceivers, page 1-12](#)
- [CWDM Optics, page 1-12](#)

SFP+ Transceivers

The enhanced SFP+ 10-Gigabit Ethernet transceiver module is a bidirectional device with a transmitter and receiver in the same physical package. It has a 20-pin connector on the electrical interface and duplex LC connector on the optical interface. The Cisco Nexus 5596 supports the SFP-10G-SR transceiver.

Model	Description
SFP-10G-SR	10-Gigabit Ethernet—short range SFP+ module

SFP+ Copper Cables

Copper cables are available for use with the 10-Gigabit Ethernet SFP+ module. The cables come in the following lengths:

- 1 m, 30 AWG
- 3 m, 28–30 AWG
- 5 m, 26–28 AWG

Model	Description
SFP-H10GB-CU1M	10GBASE-CU SFP+ Cable (1 meter)
SFP-H10GB-CU3M	10GBASE-CU SFP+ Cable (3 meters)
SFP-H10GB-CU5M	10GBASE-CU SFP+ Cable (5 meters)

SFP Fibre Channel Transceivers

The Cisco Nexus 5596 switch also supports the following SFP Fibre Channel transceiver:

Model	Description
DS-SFP-FC4G-SW	4-, 2-, or 1-Gbps Fibre Channel—Short wavelength SFP module

CWDM Optics

The Cisco Nexus 5596 switch also supports the following CWDM optics:

Model	Description
DS-CWDM4G1470=	1470 nm CWDM 1/2/4-Gbps Fibre Channel SFP
DS-CWDM4G1610=	1610 nm CWDM 1/2/4-Gbps Fibre Channel SFP

Cisco Nexus 5596T Switch

The Nexus 5596T is based on the same ASIC and chassis as the 5596UP. The Nexus 5596T switch is a 2RU switch, with 32 fixed ports of 10G BaseT and 16 fixed 10G Unified ports, which support (Ethernet, FC, FCoE). All the existing GEMs supported on the Nexus 5500 switches will be supported on the Nexus 5596T. In addition, the Nexus 5596T will also support the new 12 port 10G BaseT expansion module. With this module, you can use the Nexus 5596T to deploy up to 68 ports of 10G BaseT in a 2RU form factor. The 10G BASE-T ports support FCoE up to 30m distance with Category 6a and Category 7 cable.

This switch supports both front-to-back (port-side exhaust) and back-to-front (port-side intake) airflow. The 12 port 10G BaseT module will be supported on the Nexus 5596T chassis. The orderability information is as follows:

- N5K-C5596T-FA: Nexus 5596T 2RU, 2PS/4Fans, 32x10GT/16xSFP+ Fixed Ports
- N55-M12T: Nexus 5500 Module 12p 10GT

This section describes the Cisco Nexus 5596T switch and its components. This section includes the following topics:

- [Features, page 1-13](#)
- [Chassis, page 1-13](#)
- [Ports, page 1-15](#)
- [Power Supply, page 1-16](#)
- [Fan Module, page 1-16](#)
- [Transceivers, page 1-16](#)

Features

The Cisco Nexus 5596T switch is a 2RU switch, with 32 fixed ports of 10GBASE-T and 16 SFP+ fixed ports. The switch also supports up to three expansion slots. The switch supports 10 Gigabit Ethernet (fiber and copper), Fibre Channel, and FCoE, offering up to 1920 Gbps of throughput and up to 96 ports. The switch supports unified ports on all SFP+ ports. The hardware for the 10GBASE-T ports is capable of supporting FCoE. FCoE on 10GBaseT ports is supported only for lengths less than or equal to 30m.

The Cisco Nexus 5596T switch has the following features:

- 32 fixed ports of 10GBASE-T and 16 fixed ports of SFP+ on the back of the switch
- Three slots on the back of the switch for optional expansion modules
- Two slots on the front of the switch for hot swap-capable power supplies, which provide back-to-front (port-side exhaust) or front-to-back (port-side intake) airflow for cooling (this switch supports only one direction of airflow at a time for all modules)
- Four slots on the front of the switch for hot swap-capable fan modules, which provide back-to-front (port-side exhaust) or front-to-back (port-side intake) airflow for cooling (this switch supports only one direction of airflow at a time for all modules).
- Layer 2 or Layer 3 I/O modules
- One USB port on the front of the switch

Chassis

The Cisco Nexus 5596T chassis is 2 RU or 3.47 inches (8.8 cm) tall, 17.3 inches (43.9 cm) wide, and 29.5 inches (74.9 cm) deep. It is designed to be mounted in a standard 19-inch wide rack. The front of the switch is shown in [Figure 1-13](#).

Figure 1-13 Front View of the Cisco Nexus 5596T Switch

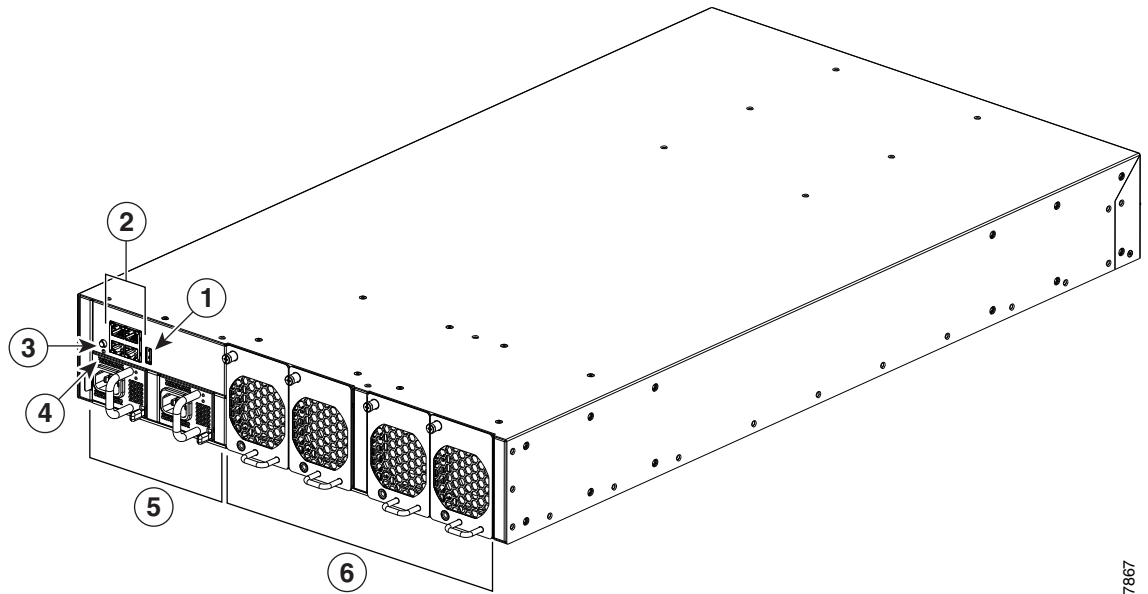

237867

1	USB port	4	System status LED
2	Management and console ports (two RJ-45 Ethernet connector ports on the left, a RJ-45 network management connector on the upper right, and a console connector on the lower right)	5	Two power supplies
3	Identifier LED	6	Four fan modules

The management and console ports are in a 2 x 2 stacked RJ-45 jack. [Figure 1-2](#) shows a close-up view of these ports. For information about the connector port LEDs, see [Table D-1 on page D-2](#).

The rear of the Cisco Nexus 5596T chassis, shown in [Figure 1-14](#), has 32 fixed ports of 10GBASE-T and 16 fixed ports of SFP+. It also has up to three expansion slots.

Figure 1-14 Rear View of the Cisco Nexus 5596T Switch

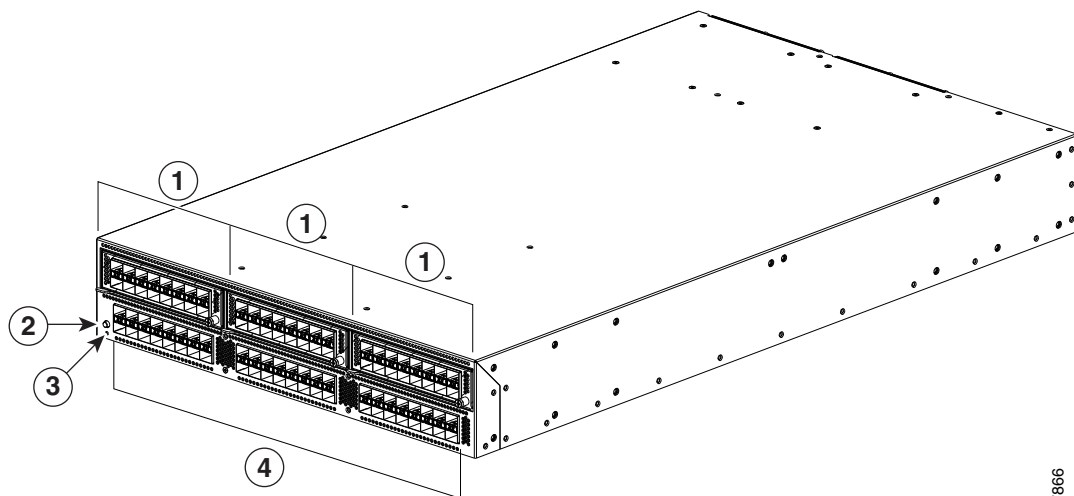

237866

1	Expansion modules	3	System status LED
2	Identifier LED	4	32 fixed ports of 10GBASE-T and 16 fixed ports of SFP+

Expansion Modules

Expansion modules allow the Cisco Nexus 5596T switch to be configured as cost-effective 10-Gigabit Ethernet switches and as I/O consolidation platforms with native Fibre Channel connectivity.

The Cisco Nexus 5596T switch has three slots that can be used for the following optional expansion modules:

- Ethernet module that provides sixteen 1- or 10-Gigabit Ethernet and FCoE ports using the SFP+ interface
- Fibre Channel plus Ethernet module that provides eight 1- or 10-Gigabit Ethernet and FCoE ports using the SFP+ interface, and eight ports of 8/4/2/1-Gbps native Fibre Channel connectivity using the SFP+/SFP interface
- Unified port module that provides up to sixteen 1- or 10-Gigabit Ethernet and FCoE ports using the SFP+ interface or up to sixteen ports of 8/4/2/1-Gbps native Fibre Channel connectivity using the SFP+ and SFP interfaces. The use of 1- or 10-Gigabit Ethernet or 8/4/2/1-Gbps Fibre Channel on a port is mutually exclusive but can be selected for any of the 16 physical ports per module
- Ethernet module that provides twelve 10GBASE-T ports (N55-M12T). The hardware is FCoE capable

You can hot swap the expansion modules during operations.



Note

When a Layer 3 I/O module is inserted into a Cisco Nexus 5500 Series switch that does not have any other I/O modules, you cannot use port-channel numbers 127 and 128 as these port-channel numbers are used by the switch for internal communication. However, if port-channel numbers 127 and 128 have already been used before a Layer 3 I/O module is inserted into the switch, new port-channel numbers will be used by the switch for internal communication.

Ports

Each port on the Cisco Nexus 5596T is numbered, and groups of ports are numbered based on their function. The ports are numbered top to bottom and left to right.

[Figure 1-15](#) shows how ports are numbered and grouped by function.

Figure 1-15 Port Numbering

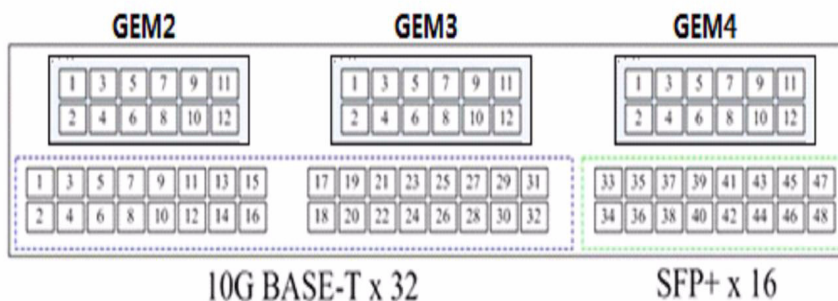

Power Supply

The Cisco Nexus 5596T uses a front-end power supply. The chassis has slots for two power supplies. The Cisco Nexus 5596T switch is fully functional with one power supply, but you can include a second power supply for power redundancy.

Table 1-1 lists the power supplies that you can order with the Cisco Nexus 5596UP and 5596T switches.



Note

Front-to-Back (port-side exhaust) airflow and DC power supplies are now supported for the Cisco Nexus 5596T. For details see the [Cisco Nexus 5500 Datasheet](#).

Figure 1-8, Figure 1-9, Figure 1-10, and Figure 1-11 show the power supplies that can be ordered with the Cisco Nexus 5596UP and 5596T switches. For more information on the LEDs, see Table D-1 on page D-2.



Note

Never leave a power supply slot empty. If you remove a power supply, replace it with another one. If you do not have a replacement power supply, leave the non functioning one in place until you can replace it.

Fan Module

The Cisco Nexus 5596T switch has four fan modules. Although the switch can function when a fan stops functioning within a fan module, if a whole fan module stops functioning, you must replace the fan module. The Cisco Nexus 5596T supports either front-to-back (port-side exhaust) or back-to-front (port-side intake) airflow (all fan and power supply modules must support the same direction of airflow).

Transceivers

The Cisco Nexus 5596T switch supports both SFP and SFP+ Ethernet transceivers and SFP Fibre Channel transceivers.

This section includes the following topics:

- [SFP+ Transceivers, page 1-17](#)
- [SFP+ Copper Cables, page 1-17](#)

- [SFP Fibre Channel Transceivers, page 1-17](#)
- [CWDM Optics, page 1-12](#)

SFP+ Transceivers

The enhanced SFP+ 10-Gigabit Ethernet transceiver module is a bidirectional device with a transmitter and receiver in the same physical package. It has a 20-pin connector on the electrical interface and duplex LC connector on the optical interface.

Model	Description
SFP-10G-SR	10-Gigabit Ethernet—short range SFP+ module
SFP-10G-LR(=)	10GBASE-LR SFP+ Module
SFP-10G-ER(=)	10GBASE-ER-SFP+ Module

SFP+ Copper Cables

Copper cables are available for use with the 10-Gigabit Ethernet SFP+ module. The cables come in the following lengths:

- 1 m, 30 AWG
- 3 m, 28–30 AWG
- 5 m, 26–28 AWG

Model	Description
SFP-H10GB-CU1M	10GBASE-CU SFP+ Cable (1 meter)
SFP-H10GB-CU3M	10GBASE-CU SFP+ Cable (3 meters)
SFP-H10GB-CU5M	10GBASE-CU SFP+ Cable (5 meters)

SFP Fibre Channel Transceivers

The Cisco Nexus 5596T switch also supports the following SFP Fibre Channel transceiver:

Model	Description
DS-SFP-FC4G-SW	4-, 2-, or 1-Gbps Fibre Channel—Short wavelength SFP module

CWDM Optics

The Cisco Nexus 5596T switch also supports the following CWDM optics:

Model	Description
DS-CWDM4G1470=	1470 nm CWDM 1/2/4-Gbps Fibre Channel SFP
DS-CWDM4G1610=	1610 nm CWDM 1/2/4-Gbps Fibre Channel SFP

Cisco Nexus 5548UP and 5548P Switches

This section describes the Cisco Nexus 5548UP and 5548P switches and their components. The Cisco Nexus 5548UP switch provides universal ports that support Ethernet and fibre channel over Ethernet (FCoE) connections. The Cisco Nexus 5548P switch provides ports that support Ethernet connections. Collectively, these switches are referred to as Cisco Nexus 5548 switches.

This section includes the following topics:

- [Features, page 1-18](#)
- [Chassis, page 1-18](#)
- [Expansion Modules, page 1-20](#)
- [Data Ports, page 1-23](#)
- [Power Supplies, page 1-23](#)
- [Fan Modules, page 1-25](#)
- [Transceivers and Cables, page 1-26](#)

Features

The Cisco Nexus 5548UP switch is a 10-Gigabit Ethernet and FCoE switch that offers up to 960-Gbps throughput and up to 48 ports. The switch has 32 fixed 1- or 10-Gbps SFP+ Ethernet and FCoE ports and one expansion slot. The expansion slot supports GEMs that offer 16 10-Gigabit Ethernet ports, eight 10-Gigabit Ethernet ports and eight 10-Gigabit FCoE ports, or 16 10-Gigabit Ethernet/FCoE ports. This switch has an orange label with “Cisco Nexus 5548UP” above the Cisco logo on the front of the chassis.

The Cisco Nexus 5548P switch is a 10-Gigabit Ethernet switch that offers up to 960-Gbps throughput and up to 48 ports. The switch has 32 fixed 1- or 10-Gbps SFP+ Ethernet and FCoE ports and one expansion slot. The expansion slot supports GEMs that offer 16 10-Gigabit Ethernet ports or eight 10-Gigabit Ethernet ports and eight 10-Gigabit FCoE ports. This switch has a gray label with “Cisco Nexus 5548P” above the Cisco logo on the front of the chassis.

As a top-of-rack switch, all the servers in the rack connect to the Cisco Nexus 5548UP or Cisco Nexus 5548P switch, and it connects to the LAN or SAN.

The Cisco Nexus 5548UP and 5548P switches have the following features:

- One slot on the back of the switch for a Generic Expansion Module (GEM). Two slots on the front of the switch for hot swap-capable power supplies.
- Two slots on the front of the switch for hot swap-capable fan modules. You can insert four fans per module, which gives you a total of eight fans.
- One slot at the front of the switch for a USB port.
- Front-to-back (port-side exhaust) cooling that supports efficient data center hot and cold-aisle designs. The Cisco Nexus 5548UP alternatively supports back-to-front (port-side intake) cooling (all fan and power supply modules in the same chassis must support the same direction of airflow).

Chassis

The Cisco Nexus 5548 switch chassis is 1 RU, 1.72 inches (4.4 cm) tall, 17.3 inches (43.9 cm) wide, and 29.5 inches (74.9 cm) deep. It is designed to be mounted in a standard 19-inch (48.26 cm) rack. The switch has two power supplies and two fans modules on the front of the switch. The switch also has one USB port (usb1:) at the front of the switch. This external USB flash memory is installed in a supervisor

module used for storing image files, configuration files, and other miscellaneous files. You can create directories on external flash memory and navigate through these directories. You can also create and access files.

The usb1: port usage on the Cisco Nexus 5548 switch is the same as that on other Cisco NX-OS devices. (For details, see the chapter, “Using the Device File Systems, Directories, and Files” in the *NX-OS Fundamentals Configuration Guide* for your software release.)

Thirty-two fixed 10-Gigabit Ethernet ports and expansion modules are at the rear of the switch. The front of the switch has an indicator LED, management ports, 2 fan modules and 2 power supplies as shown in Figure 1-16.

Figure 1-16 Cisco Nexus 5548 Switch Front View

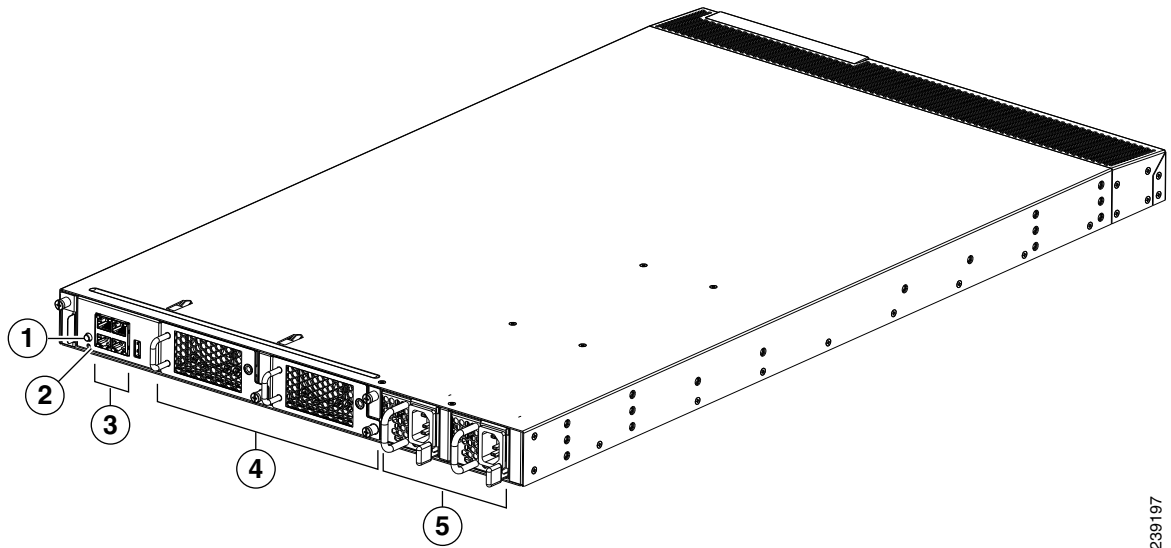

239197

1	ID LED	4	Two fan modules
2	Status LED	5	Two power supplies
3	Management (10/100/1000) ports, console port, and USB port		

The rear of the Cisco Nexus 5548 switch chassis has 32 fixed 10-Gigabit ports and 1 slot for an optional expansion module. On the Cisco Nexus 5548UP switch, the 32 fixed ports are 10-Gigabit Ethernet and FCoE ports (port numbering is shown with an orange label). On the Cisco 5548P switch, the 32 fixed ports are 10-Gigabit Ethernet ports (port numbering is shown with a gray label). Figure 1-17 shows the rear of the Cisco Nexus 5548 switch.

Figure 1-17 Cisco Nexus 5548 Switch Rear View

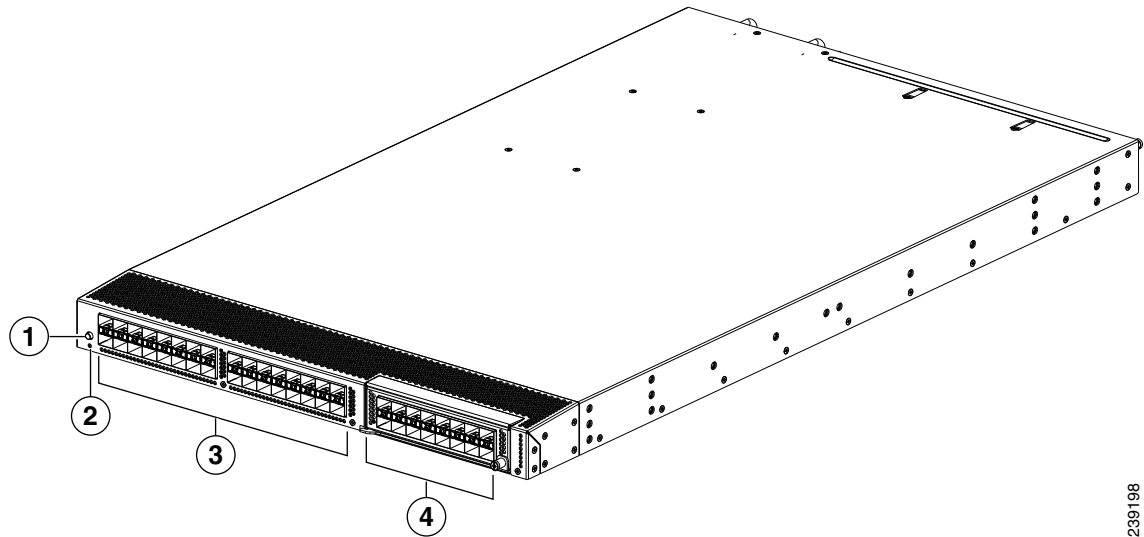

239198

1	ID LED	3	32 fixed 10-Gigabit Ethernet/FCoE ports (Cisco Nexus 5548UP) or 32 fixed 10-Gigabit Ethernet ports (Cisco Nexus 5548P)
2	Status LED	4	Expansion module

**Note**

The L1/L2/Mgmt1 ports are not usable. They are disabled at this time

Expansion Modules

Expansion modules allow Cisco Nexus switches to be configured as cost-effective 10-Gigabit Ethernet switches and as I/O consolidation platforms with native Fibre Channel connectivity.

The Cisco Nexus 5500 Platform is equipped with expansion modules that you can use to increase the number of 10-Gigabit Ethernet and FCoE ports or connect to Fibre Channel SANs with 8-, 4-, 2-, or 1-Gbps Fibre Channel switch ports. The chassis supports hot swapping of the expansion modules.

**Note**

When a Layer 3 I/O module is inserted into a Cisco Nexus 5500 Series switch that does not have any other I/O modules, you cannot use port-channel numbers 127 and 128 as these port-channel numbers are used by the switch for internal communication. However, if port-channel numbers 127 and 128 have already been used before a Layer 3 I/O module is inserted into the switch, new port-channel numbers will be used by the switch for internal communication.

The Cisco Nexus 5548 supports one of the following expansion modules:

- [N55 M16P Generic Expansion Module, page 1-21](#)
- [N55 M8P8FP Generic Expansion Module, page 1-21](#)
- [N55 M16UP Generic Expansion Module, page 1-22](#)

N55 M16P Generic Expansion Module

The N55 M16P Generic Expansion Module (GEM) provides 16 1- or 10-Gigabit Ethernet ports using the SFP+ transceiver.

Figure 1-18 shows the components that you use to install this expansion module.

Figure 1-18 Components Used to Install the N55 M16P GEM

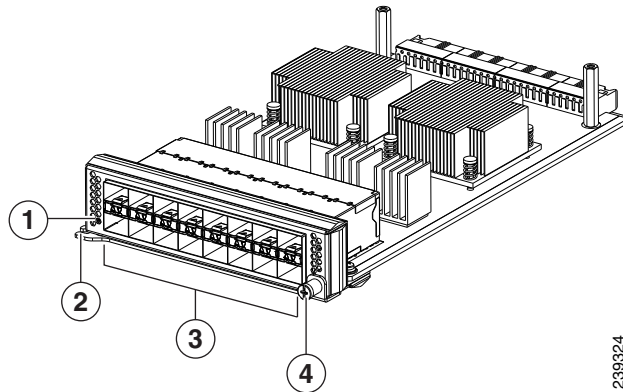

1	Status LED	3	16 10-Gigabit Ethernet ports
2	Ejector lever	4	Captive screw that locks the ejector lever

Figure 1-19 shows the front of the module and how its ports are numbered.

Figure 1-19 Port Numbering for the N55 M16P GEM

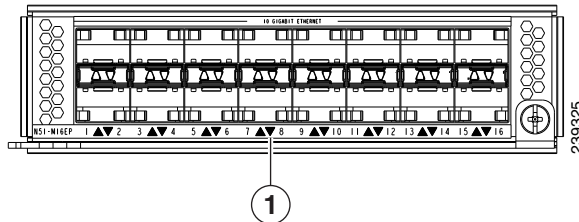

1	Port numbering from top to bottom and left to right	
----------	---	--

N55 M8P8FP Generic Expansion Module

The N55 M8P8FP Generic Expansion Module (GEM) provides 8 1- or 10-Gigabit Ethernet and FCoE ports using the SFP+ interface and 8 ports of 8-, 4-, 2-, or 1-Gbps native Fibre Channel connectivity using the SFP interface.

Figure 1-20 shows the N55 M8P8FP expansion module.

Figure 1-20 Components Used to Install the N55 M8P8FP GEM

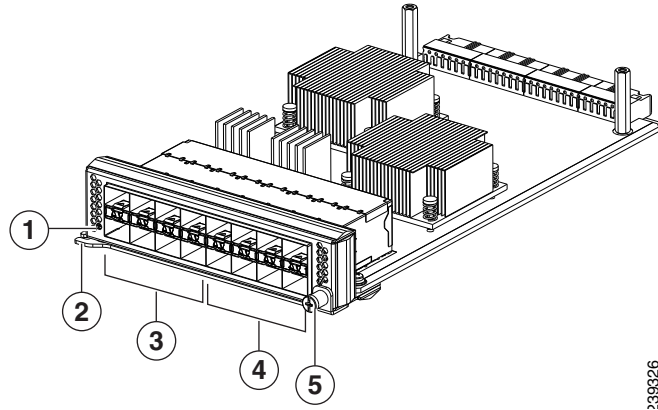

1	Status LED	4	Eight 10-Gigabit FCoE ports
2	Ejector lever	5	Captive screw that locks the ejector lever
3	Eight 10-Gigabit Ethernet ports		

Figure 1-21 shows a front view of the N55 M8P8FP expansion module.

Figure 1-21 Port Numbering on the N55 M8P8FP GEM

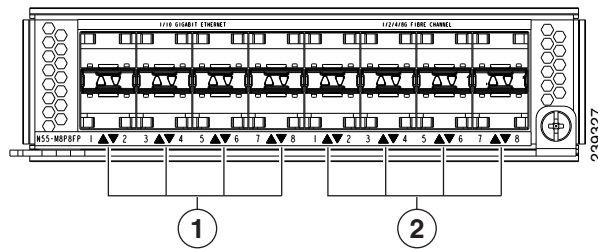

1	Port numbering for Ethernet ports (from top to bottom and left to right)	2	Port numbering for FCoE ports (from top to bottom and left to right)
----------	--	----------	--

N55 M16UP Generic Expansion Module

The N55 M16UP Generic Expansion Module (GEM) provides 16 1- or 10-Gigabit Ethernet and FCoE ports using SFP+ transceivers.

Figure 1-22 shows the components that you use to install this expansion module.

Figure 1-22 Components Used to Install the N55 M16UP GEM

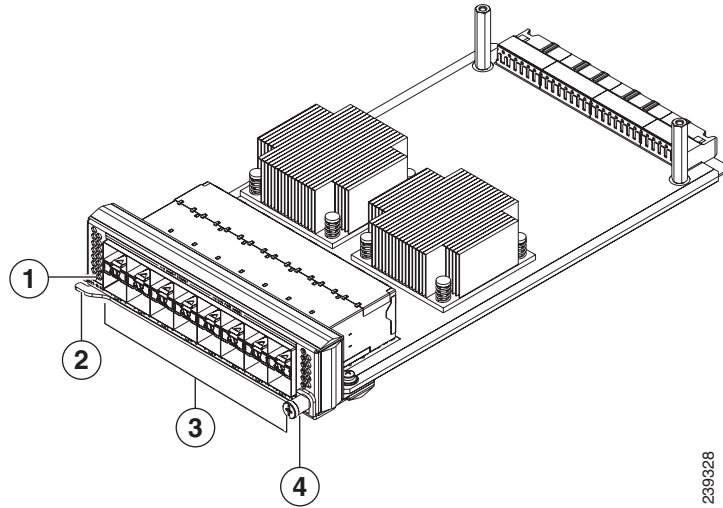

1	Status LED	3	16 10-Gigabit Ethernet and FCoE ports
2	Ejector lever	4	Captive screw that locks the ejector lever

The ports are numbered the same as with the N55-M16P GEM (see [Figure 1-19 on page 1-21](#))

Data Ports

Each data port on the Cisco Nexus 5548 switch is numbered, and groups of ports are numbered based on their function. The ports are numbered from top to bottom and left to right.

Figure 1-23 Port Numbering of the Cisco Nexus 5548 Switch with an Expansion Module

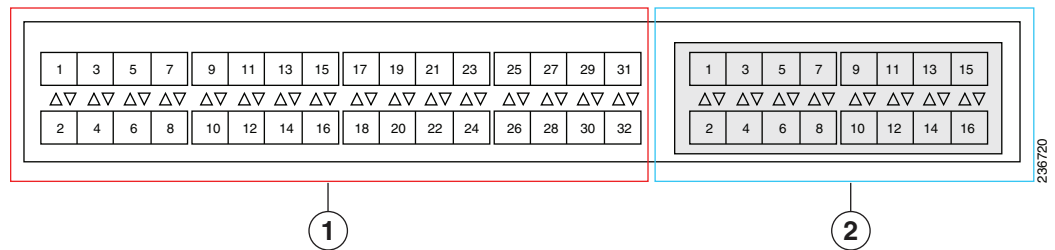

1	32 fixed ports	2	16-port expansion module (N55 M16P, N55 M8P8FP, or N55 M16UP)
----------	----------------	----------	---

Power Supplies

The Cisco Nexus 5548 switches uses a front-end power supply. The chassis has slots for two power supplies. Two power supplies can be used for redundancy, but the Cisco Nexus 5548 switch is fully functional with one power supply. See [Table 1-2](#) for the list of power supplies that you can order with the Cisco Nexus 5548UP and 5548P switches. Note that the Cisco Nexus 5548P switch supports only front-to-back (port-side exhaust) airflow and the Cisco Nexus 5548UP switch supports either front-to-back (port-side exhaust) or back-to-front (port-side intake) airflows.

Table 1-2 Power Supplies for the Cisco Nexus 5500 Platform switches

Part Number	Power Supply
N55-PAC-750W	Cisco Nexus 5548P/5548UP PSU Front-to-Back (port-side exhaust) Airflow module, A/C, 100-240V, 750W
N55-PAC-750W(=)	Cisco Nexus 5548P/5548UP PSU Front-to-Back (port-side exhaust) Airflow module spare, A/C, 100-240V, 750W
N55-PAC-750W-B	Cisco Nexus 5548UP PSU Back-to-Front (port-side intake) Airflow module, A/C, 100-240V, 750W
N55-PAC-750W-B(=)	Cisco Nexus 5548UP PSU Back-to-Front (port-side intake) Airflow module spare, A/C, 100-240V, 750W
N55-PDC-750W	Cisco Nexus 5548P/5548UP PSU Front-to-Back (port-side exhaust) Airflow module, D/C, -40 to -72VDC, 750W
N55-PDC-750W(=)	Cisco Nexus 5548P/5548UP PSU Front-to-Back (port-side exhaust) Airflow module spare, D/C, -40 to -72VDC, 750W

**Caution**

All of the power supply and fan modules in the same chassis must use the same airflow direction or an error will occur with possible over heating and shut down of the switch. If you power up the switch with more than one airflow direction, you must power down the switch and replace the modules with the wrong airflow direction (modules not taking in coolant air from the cold aisle) before powering up the switch.

Figure 1-24 shows the 750W DC power supply. For specifications for this power supply, see [Table B-11 on page B-4](#). For more information on the LEDs, see [Table D-1 on page D-2](#)

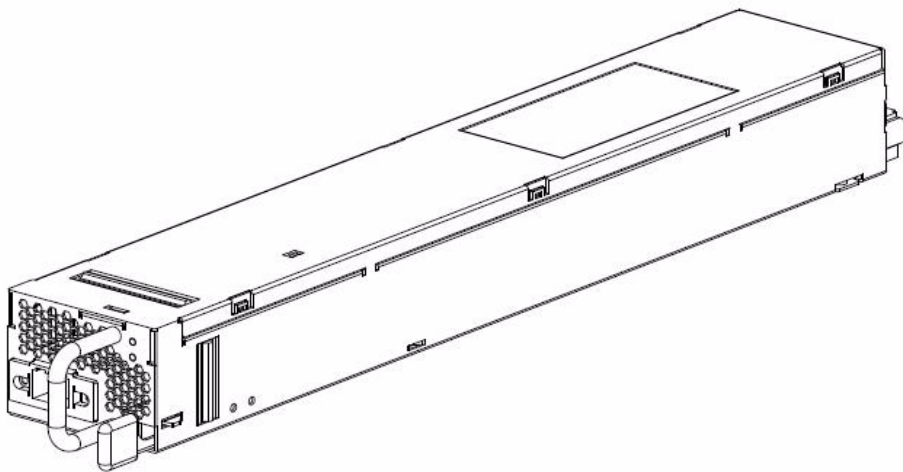
Figure 1-24 750 W DC Power Supply for the Cisco Nexus 5500 Series Switch

1	Handle	4	Ejector latch
2	FAIL (left) and OK (right) LEDs		
3	DC power receptacle		

**Note**

Never leave a power supply slot empty. If you remove a power supply, replace it with another one. If you do not have a replacement power supply, leave the non functioning one in place until you can replace it.

The Cisco Nexus 5548UP has front-to-back (port-side exhaust) or back-to-front (port-side intake) airflow. The Cisco Nexus 5548P has front-to-back (port-side exhaust) airflow only. [Figure 1-25](#) shows the AC power supply, with two LEDs: one for power status and one for failure condition.

Figure 1-25 AC Power Supply for the Cisco Nexus 5548 Switch

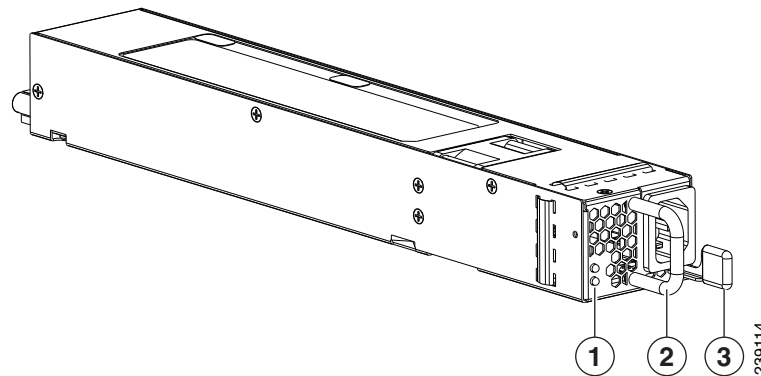

1	FAIL (top) and OK (bottom) LEDs	3	Release latch
2	Handle		

For information on each of the LEDs, see [Table D-1 on page D-2](#). To see how combinations of these LED states indicate specific conditions, see the [“Power Supply Conditions” section on page E-2](#).

**Note**

Never leave a power supply slot empty. If you remove a power supply, replace it with another one. If you do not have a replacement power supply, leave the non functioning one in place until you can replace it.

For the specifications of this power supply, see [Table B-12 on page B-5](#).

**Caution**

The airflow direction should be the same for power supplies and fan modules.

Fan Modules

The Cisco Nexus 5548 switches require two fan modules. Each fan module has four fans. If more than one fan fails in one of these modules, you must replace the module. [Figure 1-26](#) identifies the components that you use to install or troubleshoot these modules.

Figure 1-26 Cisco Nexus 5548 Fan Module

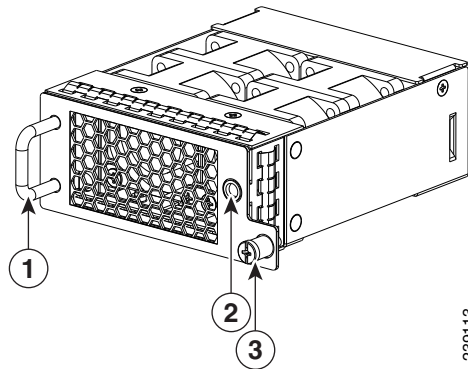

1	Handle	3	Captive screw
2	Bicolor LED (green or amber)		

The bicolor fan module LED indicates the fan tray health. Green indicates normal operation, while amber indicates a fan failure. For more information on this LED, see [Table D-1 on page D-2](#). The Cisco Nexus 5548UP has front-to-back (port-side exhaust) or back-to-front (port-side intake) airflow. The Cisco Nexus 5548P has front-to-back (port-side exhaust) airflow only.

**Caution**

All of the power supply and fan modules in the same chassis must use the same airflow direction or an error will occur with possible over heating and shut down of the switch. If you power up the switch with more than one airflow direction, you must power down the switch and replace the modules with the wrong airflow direction (modules not taking in coolant air from the cold aisle) before powering up the switch.

Transceivers and Cables

The Cisco Nexus 5548UP switch supports both SFP and SFP+ Ethernet transceivers, SFP Fibre Channel transceivers, and FET transceivers. The Cisco Nexus 5548P switch supports SFP and SFP+ Ethernet transceivers, and FET transceivers. The expansion modules support 1- and 10-Gigabit Ethernet SFP+ transceivers (N55 M16P expansion module), 10-Gigabit FET transceivers, and Fiber Channel SFP transceivers.

This section includes the following topics:

- [Transceivers, page 1-27](#)
- [Cables, page 1-28](#)

Transceivers

Table 1-3 lists the supported transceiver options.

Table 1-3 Supported Transceivers

Cisco SFP	Description
FET-10G	10G SFP+ module for Cisco Nexus 2000 Series to Cisco Nexus 5000 Series connectivity
Cisco SFP-10G-SR	10GBASE-SR SFP+ module (multimode fiber [MMF])
Cisco SFP-10G-LR	10GBASE-LR SFP+ module (single-mode fiber [SMF])
Cisco SFP-H10GB-CU1M	10GBASE-CU SFP+ cable 1 m (Twinax cable)
Cisco SFP-H10GB-CU3M	10GBASE-CU SFP+ cable 3 m (Twinax cable)
Cisco SFP-H10GB-CU5M	10GBASE-CU SFP+ cable 5 m (Twinax cable)
Cisco GLC-T	1000BASE-T SFP
Cisco GLC-SX-MM	GE SFP, LC connector SX transceiver (MMF)
Cisco GLC-LH-SM	GE SFP, LC connector LX/LH transceiver (SMF)
Cisco SFP-GE-T	1000BASE-T SFP, extended temperature range
Cisco SFP-GE-S	GE SFP, LC connector SX transceiver (MMF), extended temperature range and digital optical monitoring (DOM)
Cisco-SFP-GE-L	GE SFP, LC connector LX/LH transceiver (SMF), extended temperature range and DOM
Cisco DS-SFP-FC4G-SW	4-Gbps Fibre Channel SW SFP, LC (supported in unified ports in the 5548UP, and in the expansion module ports)
Cisco DS-SFP-FC4G-LW	4-Gbps Fibre Channel LW SFP, LC (supported in unified ports in the 5548UP, and in the expansion module ports)
Cisco DS-SFP-FC8G-SW	8-Gbps Fibre Channel SW SFP+, LC (supported in unified ports in the 5548UP, and in the expansion module ports)
Cisco DS-SFP-FC8G-LW	8-Gbps Fibre Channel LW SFP+, LC (supported in unified ports in the 5548UP, and in the expansion module ports)

This section includes the following topics:

- [SFP+ Transceivers, page 1-27](#)
- [SFP+ Copper Cables, page 1-28](#)
- [SFP Fibre Channel Transceivers, page 1-28](#)
- [Cables, page 1-28](#)

SFP+ Transceivers

The enhanced small-form-factor pluggable (SFP+) 10-Gigabit Ethernet transceiver module (see [Table 1-4](#)) is a bidirectional device with a transmitter and receiver in the same physical package. It has a 20-pin connector on the electrical interface and duplex LC connector on the optical interface. The Cisco Nexus 5548 switch supports the following SFP+ optical transceivers:

- SR

- LR (for uplink only)

Table 1-4 SFP+ Transceivers

Model	Description
SFP-10G-SR	10-Gigabit Ethernet—Short range SFP+ module
SFP-10G-LR	10-Gigabit Ethernet—Long range SFP+ module

SFP+ Copper Cables

Copper cables are available for use with the 10-Gigabit Ethernet SFP+ module (see [Table 1-5](#)). The cables come in the following lengths:

- 1 m, 30 AWG
- 3 m, 28–30 AWG
- 5 m, 26–28 AWG
-

Table 1-5 SFP+ Copper Cables

Model	Description
SFP-H10GB-CU1M	10GBASE-CU SFP+ cable (1 meter)
SFP-H10GB-CU3M	10GBASE-CU SFP+ cable (3 meters)
SFP-H10GB-CU5M	10GBASE-CU SFP+ cable (5 meters)

SFP Fibre Channel Transceivers

The Cisco Nexus 5548 switch supports the multimode 850-nm, 4-Gbps SFPs with 150-m reach (see [Table 1-6](#)).

Table 1-6 SFP Fibre Channel Transceivers

Model	Description
DS-SFP-FC4G-SW	4-Gbps Fibre Channel-SW SFP, LC
DS-SFP-FC4G-LW	4-Gbps Fibre Channel-LW SFP, LC, (10-km reach)
Cisco DS-SFP-FC8G-SW	8-Gbps Fibre Channel SW SFP+, LC
Cisco DS-SFP-FC8G-LW	8-Gbps Fibre Channel LW SFP+, LC

Cables

On the Cisco Nexus 5500 Platforms, you can use an innovative Twinax copper cable that connects to standard SFP+ connectors for in-rack use and on the optical cable for longer cable runs.

For in-rack or adjacent-rack cabling, the Cisco Nexus 5500 Platform supports SFP+ direct-attach 10-Gigabit Ethernet copper, which integrates transceivers with Twinax cables into an energy efficient, low-cost, and low-latency solution. SFP+ direct-attach 10-Gigabit Twinax copper cables use only 0.1 W of power per transceiver and introduce only approximately 0.25 microsecond of latency per link.

For longer cable runs, the Cisco Nexus 5500 Platform supports multimode, short-reach optical SFP+ transceivers. These optical transceivers use approximately 1 W per transceiver and have a latency of less than 0.1 microsecond.

Table 1-7 shows details of the cables supported.

Table 1-7 Supported Cables

Connector (Media)	Cable	Distance	Power (each side)	Transceiver Latency (Link)	Standard
SFP+ CU copper	Twinax	5 m	Approx. 0.1 W	~ 0.1 microseconds	SFF 8431
SFP+ ACU copper	Active Twinax	7 m/ 10 m	Approx. 0.5 W	~ 6.8 nanoseconds	SFF 8461
SFP+ SR MMF and SR	MM OM2 MM OM3	82 m/ 300 m	1 W	~ 0 microseconds	IEEE 802.3ae

Cisco Nexus 5000 Platform Switches

The Cisco Nexus 5000 Platform switches include the Cisco Nexus 5020 switch and the Cisco Nexus 5010 switch.

This section includes the following topics:

- [Cisco Nexus 5020 Switch, page 1-29](#)
- [Cisco Nexus 5010 Switch, page 1-41](#)

Cisco Nexus 5020 Switch

This section describes the Cisco MDS 9200 Series. This section includes the following sections:

- [Features, page 1-30](#)
- [Chassis, page 1-30](#)
- [Expansion Modules, page 1-32](#)
- [Ports, page 1-36](#)
- [Power Supply, page 1-38](#)
- [Fan Modules, page 1-39](#)
- [Transceivers, page 1-40](#)

Features

The Cisco Nexus 5020 switch is a 2 RU, top-of-rack switch that provides Ethernet and Fibre Channel consolidation in a single physical cable. The Fibre Channel over Ethernet (FCoE) protocol is used to consolidate Ethernet and Fibre Channel traffic onto the same physical connection between the server and the switch. As a top-of-rack switch, all the servers in the rack connect to the Cisco MDS 9200 Series, and it connects to the LAN or SAN.

The Cisco MDS 9200 Series is a part of a family of switches that provide 10-Gigabit Ethernet and FCoE ports and both 10-Gigabit Ethernet and native 4-, 2-, or 1-Gbps Fibre Channel ports. The switches provide consolidated I/O connectivity to both production Ethernet LANs and Fibre Channel SANs in a cost-effective, high-performance, low-latency Ethernet switch.

The Cisco Nexus 5020 switch has the following features:

- Forty fixed 10-Gigabit Ethernet server connection ports on the back of the switch
- Two slots for optional 10-Gbps expansion modules or Fibre Channel interfaces on the back of the switch
- Two slots on the front of the switch for hot swap-capable power supplies
- Five slots on the front of the switch for hot swap-capable fan modules, each of which houses two fans, that provide front-to-back (port-side exhaust) cooling for the switch
- The L1/L2/Mgmt1 ports are not usable. They are disabled at this time

Chassis

The Cisco Nexus 5020 chassis is 2 RU (3.47 inches) tall, 17.3 inches wide, and 30.0 inches deep. It is designed to be mounted in a standard 19-inch rack. The switch has two power supplies and five fan modules on the front of the switch. Ports are at the rear of the switch. The airflow is front-to-back (port-side exhaust) so it must be positioned with the front side in a cold aisle. [Figure 1-27](#) shows the front of the Cisco Nexus 5020 switch.

Figure 1-27 Cisco Nexus 5020 Switch Front View

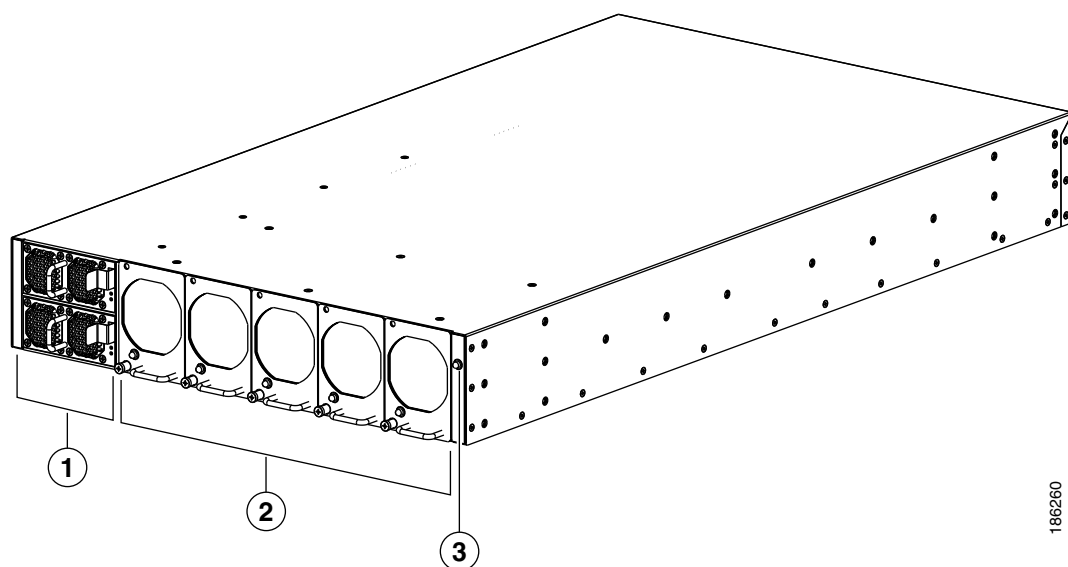

1	Two power supplies	3	System status LED
2	Five fan modules		

The rear of the Cisco Nexus 5020 chassis has 40 fixed 10-Gigabit Ethernet ports, 2 slots for optional expansion modules, an Ethernet connector with 2 cross-connect ports and 2 management ports, a console port, and 2 AC power connectors as shown in [Figure 1-28](#).

Figure 1-28 Cisco Nexus 5020 Switch Rear View

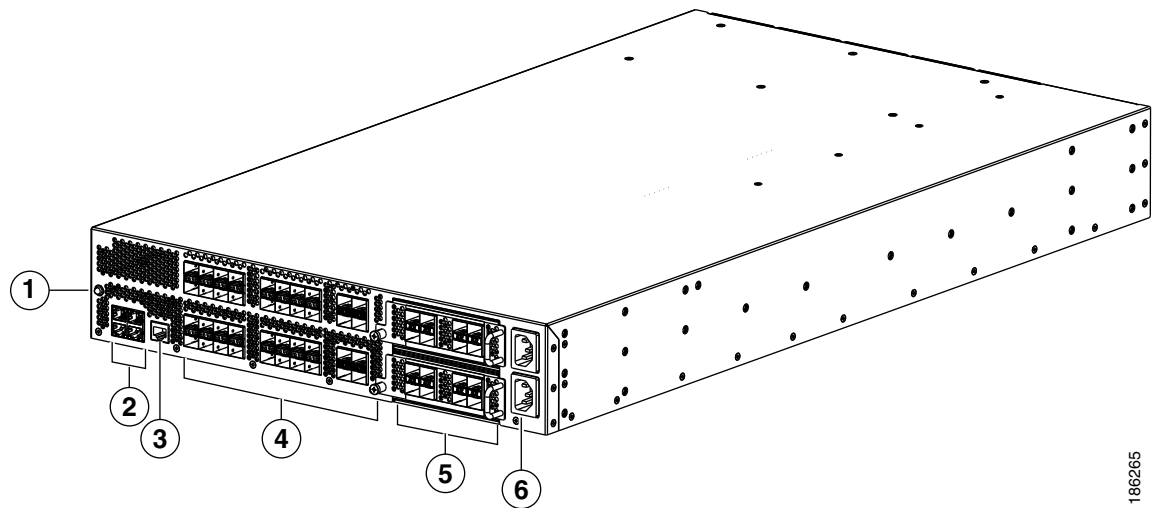

186265

1	System status LED	4	40 fixed 10-Gigabit Ethernet ports
2	Two cross-connect ports on the left (top and bottom) and two network management ports on the right (top and bottom)	5	Expansion modules, shown here with two 4-port Fibre Channel plus 4-port, 10-Gigabit Ethernet expansion modules
3	Console port	6	AC power connectors

The Ethernet connector port exposes four Ethernet ports that are in a 2 x 2 stacked RJ-45 jack. [Figure 1-29](#) shows a close-up view of the Ethernet connector port.

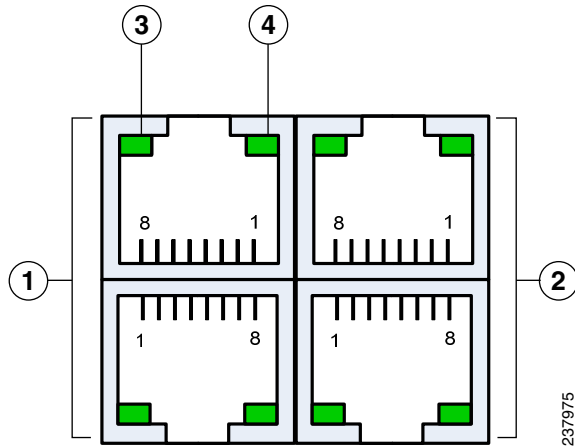
Figure 1-29 Cross-Connect and Network Management Ports

1	Internal cross-connect ports (two)	3	Link LED (left LED)
2	Network management ports (two)	4	Activity LED (right LED)

To see what each of the Ethernet port LEDs indicate, see [Table D-3 on page D-4](#).

Expansion Modules

The Cisco MDS 9200 Series has two slots that can be used for the following optional expansion modules:

- Fibre Channel plus Ethernet expansion module
- Ethernet expansion module
- N5K-M1008 Generic Expansion Module (GEM)
- N5K-M1060 GEM

The chassis supports hot swapping of the expansion modules.

This section includes the following topics:

- [Fibre Channel Plus Ethernet Expansion Module, page 1-32](#)
- [Ethernet Expansion Module, page 1-34](#)
- [N5K-M1008 Generic Expansion Module, page 1-34](#)
- [N5K-M1060 Generic Expansion Module, page 1-35](#)

Fibre Channel Plus Ethernet Expansion Module

The Fibre Channel plus Ethernet expansion module is a field-replaceable unit (FRU) that supports four SFP+ transceiver modules and four 4-, 2-, or 1-Gbps Fibre Channel transceivers. [Figure 1-30](#) shows the features that you use when installing the Fibre Channel plus Ethernet expansion module.

Figure 1-30 Fibre Channel Plus Ethernet Expansion Module Features

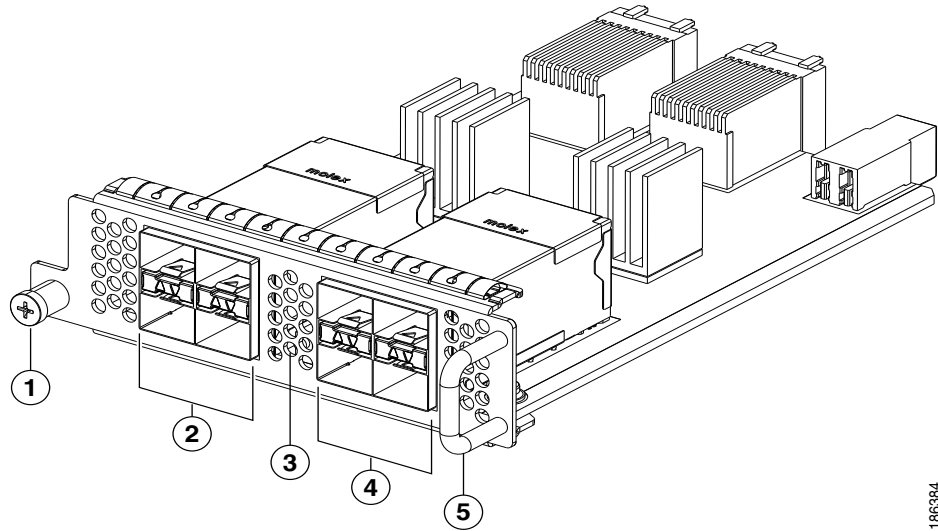

186384

1	Captive screw	4	Four 4-, 2-, and 1- Gbps Fibre Channel ports
2	Four 10-Gigabit Ethernet ports	5	Handle
3	Status LED		

Figure 1-31 shows the Ethernet and Fibre Channel ports are numbered.

Figure 1-31 Front View of the Fibre Channel Plus Ethernet Expansion Module

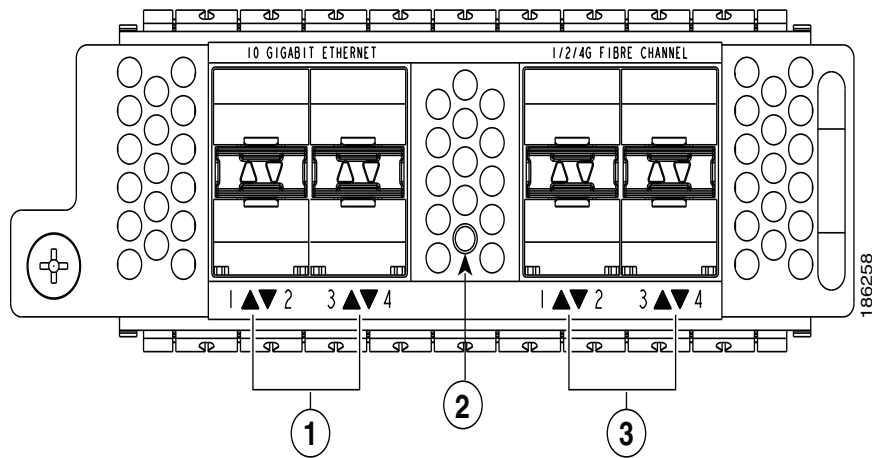

186258

1	Port numbering for the Ethernet ports	3	Port numbering for the Fibre Channel ports
2	Status LED		

Ethernet Expansion Module

The Ethernet expansion module is a field-replaceable unit (FRU) that supports six 10-Gigabit Ethernet ports, four of which have encryption capability. [Figure 1-32](#) shows the features used when installing this expansion module.

Figure 1-32 Ethernet Expansion Module

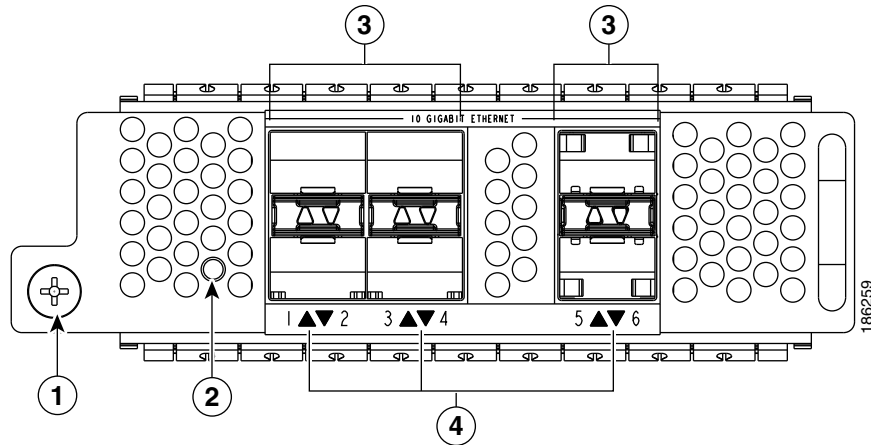

1	Captive screw	3	10-Gigabit Ethernet ports
2	Status LED	4	Port numbering for the Ethernet ports

N5K-M1008 Generic Expansion Module

The N5K-M1008 GEM supports 8 4-, 2-, or 1-Gbps Fiber Channel, SFP-based uplink connections. [Figure 1-33](#) shows the features used when installing this expansion module.

Figure 1-33 N5K-M1008 GEM

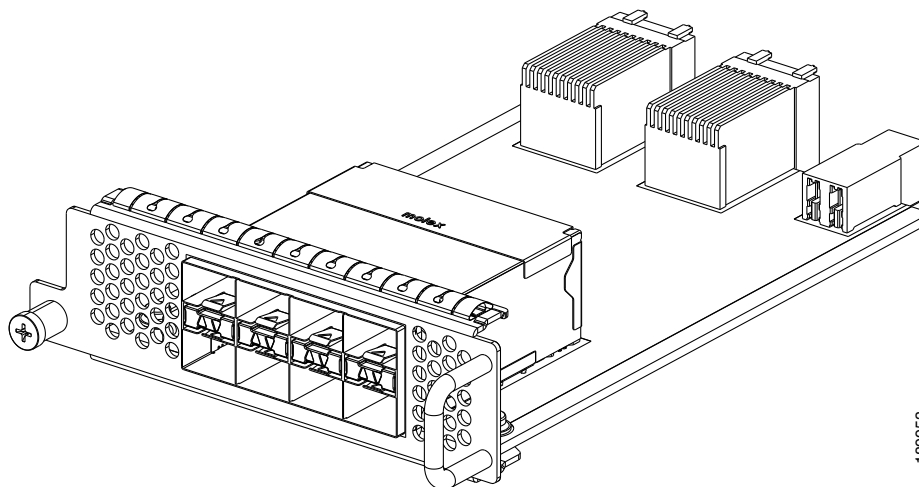
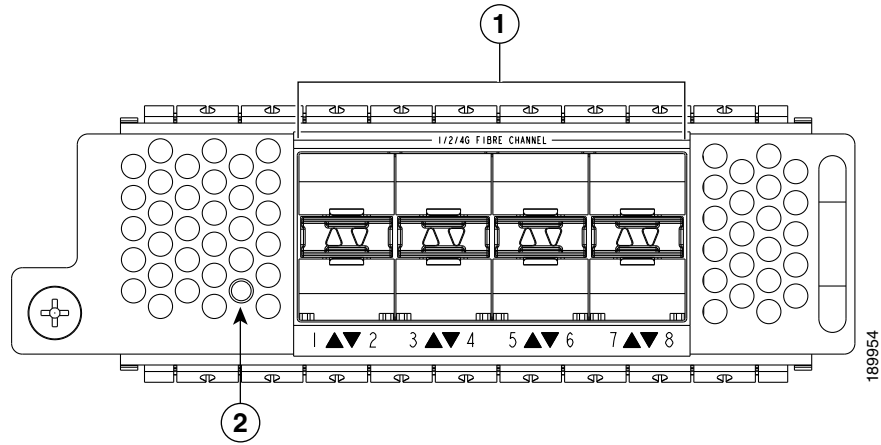

Figure 1-34 Front View of the N5K-M1008 GEM



1	Eight 4-, 2-, or 1-Gbps Fibre Channel ports	2	LED
----------	---	----------	-----

N5K-M1060 Generic Expansion Module

The N5K-M1060 expansion module provides 6 EA 8-, 4-, 2-, or 1-Gbps line rate Fiber Channel, SFP+ based uplink connections. [Figure 1-35](#) and [Figure 1-36](#) show the N5K-M1060 GEM.

Figure 1-35 N5K-M1060 GEM

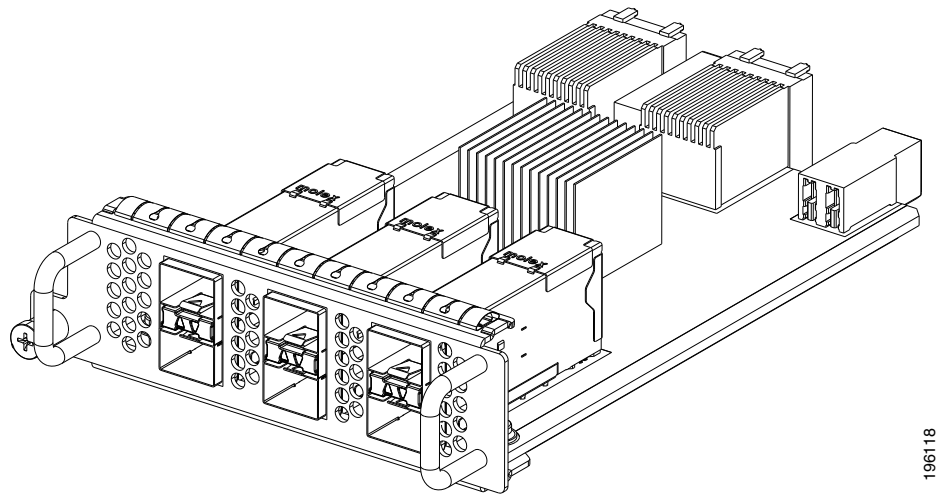
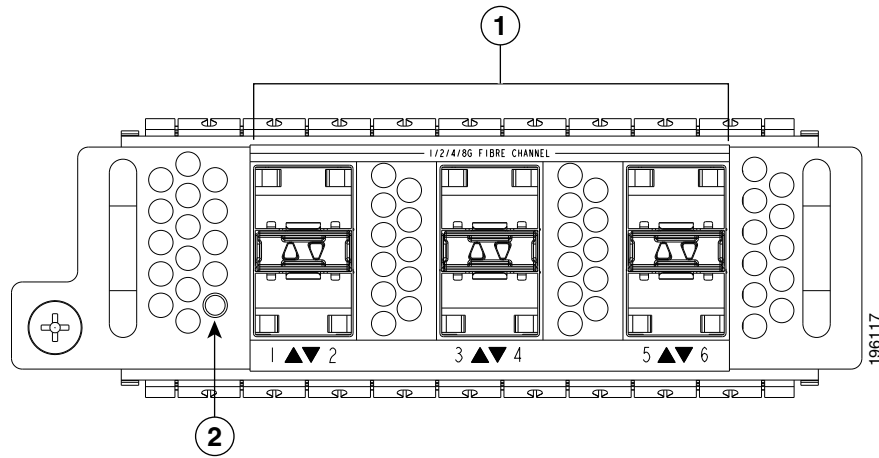

Figure 1-36 Front View of the N5K-M1060 GEM



1	Six 8-, 4-, 2-, or 1-Gbps Fibre Channel ports	2	LED
----------	---	----------	-----

Ports

Each individual port on the Cisco MDS 9200 Series is numbered, and groups of ports are numbered based on their function. The ports are numbered top to bottom and left to right. The 40 fixed ports form group 1 and are named 1/*port_number*. Ports 1 through 32 are unencrypted Ethernet ports. Of these, ports 1 through 16 are 10-Gigabit Ethernet and 1-Gigabit Ethernet-capable ports. Ports 33 through 40 are encryption-capable Ethernet ports.

Group 2 includes the ports in the top-most expansion module. Group 2, ports 1 through 4, are encrypted Ethernet ports. Group 2, ports 5 through 8, are Fibre Channel ports.

Group 3 includes the ports in the bottom-most expansion module. Group 3 ports 1 through 4 are encrypted Ethernet ports. Group 3 ports 5 through 8 are Fibre Channel ports.

[Figure 1-37](#) shows how ports are numbered and grouped by function for both the fixed ports and the Fibre Channel plus Ethernet expansion module ports.

Figure 1-37 Port Numbering of Fixed Ports and Fibre Channel Plus Ethernet Expansion Module Ports

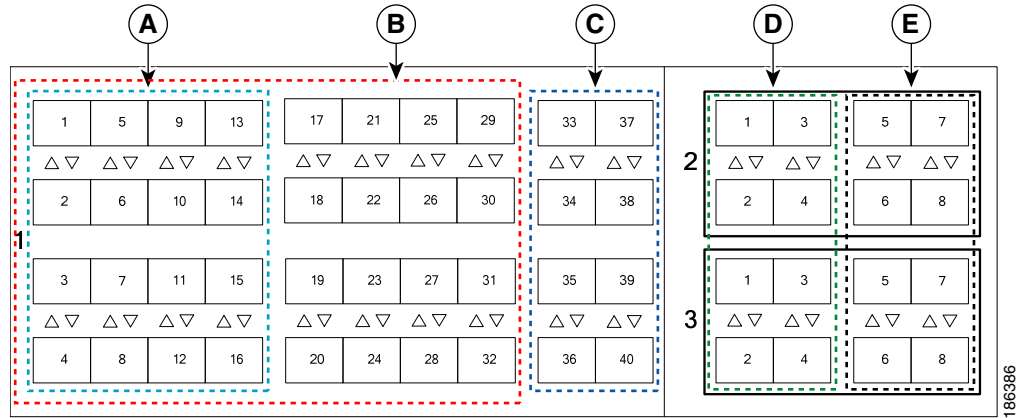

A	Group 1, ports 1 through 16: 10-Gigabit Ethernet and 1-Gigabit Ethernet capable unencrypted unencrypted ports	D	Groups 2 and 3, ports 1 through 4: Encrypted Ethernet ports
B	Group 1, ports 1 through 32: Unencrypted Ethernet ports	E	Groups 2 and 3, ports 5 through 8: Fibre Channel ports
C	Group 1, ports 33 through 40: Encrypted Ethernet ports		

Figure 1-38 shows how ports are numbered and grouped by function for both the fixed ports and the Ethernet expansion module ports.

Figure 1-38 Port Numbering of Fixed Ports and the Ethernet Expansion Module

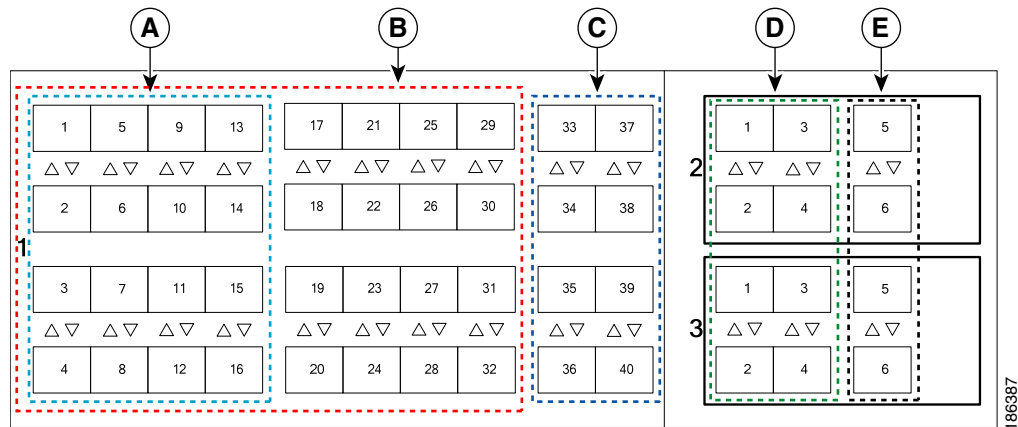

A	Group 1, ports 1 through 16: 10-Gigabit Ethernet and 1-Gigabit Ethernet-capable Encrypted ports	D	Groups 2 and 3, ports 1 through 4: Encrypted Ethernet ports
B	Group 1, ports 1 through 32: Unencrypted Ethernet ports	E	Groups 2 and 3, ports 5 through 6: Unencrypted Ethernet ports
C	Group 1, ports 33 through 40: Encrypted Ethernet ports		

Power Supply

The Cisco Nexus 5020 switch uses a front-end power supply with front-to-back (port-side exhaust) airflow. The chassis has slots for two power supplies. Two power supplies can be used for redundancy, but the Cisco MDS 9200 Series is fully functional with one power supply. [Figure 1-39](#) shows the power supply, which has two LEDs: one for the power status and one for the failure condition.

Figure 1-39 Power Supply for the Cisco Nexus 5020 Switch

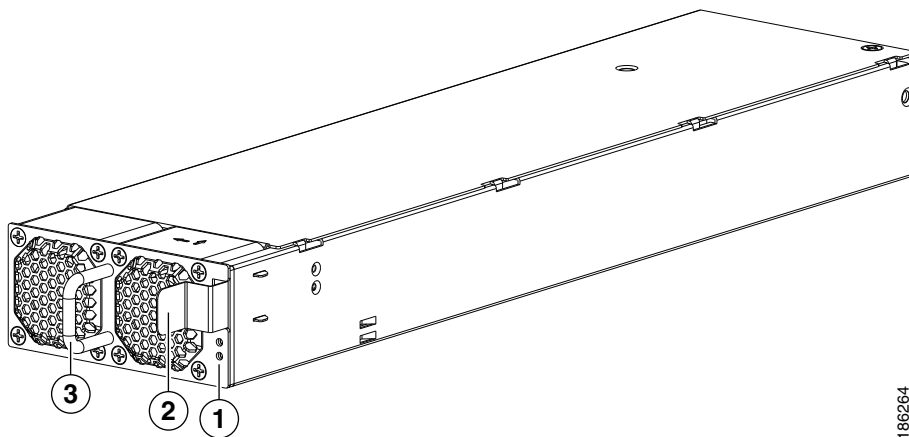

1	FAULT (top) and OK (bottom) LEDs	3	Handle
2	Release lever		

For descriptions of the LEDs, see [Table D-1 on page D-2](#). For descriptions of power supply conditions indicated by the LEDs, see [Table D-2 on page D-3](#).

If you have one power supply installed in the chassis, but the other power supply slot is empty, you should use a power supply blank panel to cover the empty slot. [Figure 1-40](#) shows a blank power supply panel.

Figure 1-40 Blank Power Supply Panel

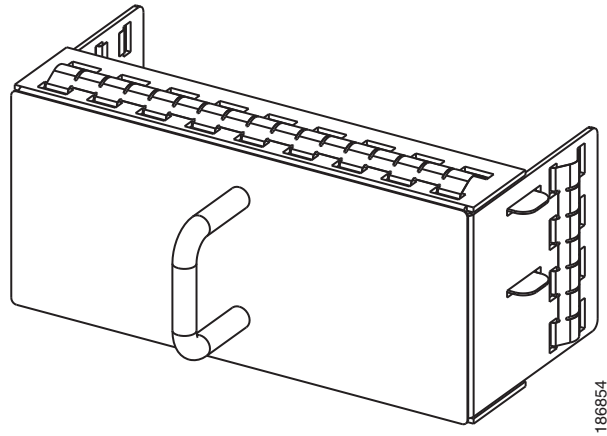

Fan Modules

The Cisco Nexus 5020 switch has five fan modules each with front-to-back (port-side exhaust) airflow. [Figure 1-41](#) shows a fan module.

Figure 1-41 Cisco Nexus 5020 Fan Module

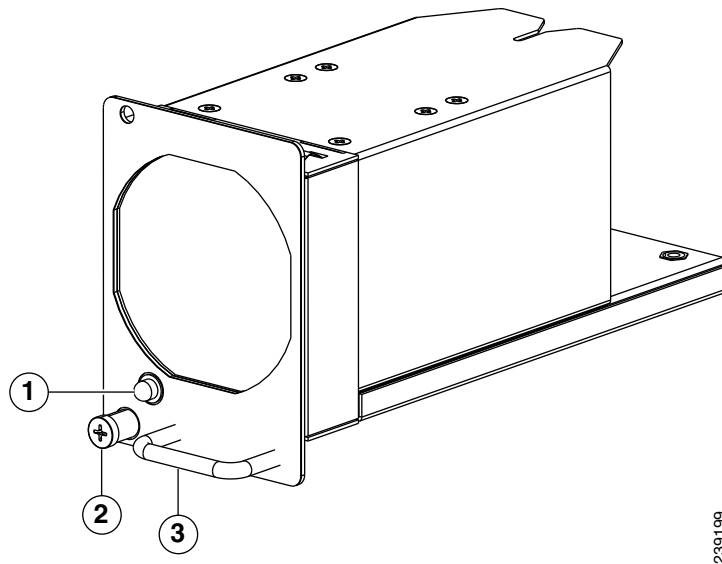

1	Fan module LED	3	Handle
2	Captive screw		

The bicolor fan module LED indicates the fan tray health. Green indicates normal operation, while amber indicates a fan failure.

Transceivers

The Cisco Nexus 5020 switch supports both SFP+ Ethernet transceivers and SFP Fibre Channel transceivers.

This section includes the following sections:

- [SFP+ Transceivers, page 1-40](#)
- [SFP+ Copper Cables, page 1-40](#)
- [SFP Fibre Channel Transceivers, page 1-41](#)

SFP+ Transceivers

The enhanced SFP+ 10-Gigabit Ethernet transceiver module is a bidirectional device with a transmitter and receiver in the same physical package (see [Table 1-8](#)). It has a 20-pin connector on the electrical interface and duplex LC connector on the optical interface. The Cisco Nexus 5020 switch supports the SFP-10G-SR transceiver.

Table 1-8 SFP+ Transceivers

Model	Description
SFP-10G-SR	10-Gigabit Ethernet—Short range SFP+ module

SFP+ Copper Cables

Copper cables are available for use with the 10-Gigabit Ethernet SFP+ module. The cables come in the following lengths:

- 1 m, 30 AWG
- 3 m, 28–30 AWG
- 5 m, 26–28 AWG

Table 1-9 SFP+ Copper Cables

Model	Description
SFP-H10GB-CU1M	10GBASE-CU SFP+ Cable (1 meter)
SFP-H10GB-CU3M	10GBASE-CU SFP+ Cable (3 meters)
SFP-H10GB-CU5M	10GBASE-CU SFP+ Cable (5 meters)

SFP Fibre Channel Transceivers

The Cisco Nexus 5020 switch also supports the following SFP Fibre Channel transceivers (see [Table 1-10](#)):

Table 1-10 SFP Fibre Channel Transceiver

Model	Description
DS-SFP-FC4G-SW	4-, 2-, or 1-Gbps Fibre Channel—short wavelength SFP module

Cisco Nexus 5010 Switch

This section describes the Cisco Nexus 5010 switch and its components. This section includes the following topics:

- [Features, page 1-41](#)
- [Chassis, page 1-42](#)
- [Expansion Modules, page 1-43](#)
- [Ports, page 1-48](#)
- [Power Supplies, page 1-49](#)
- [Fan Modules, page 1-50](#)
- [Transceivers, page 1-51](#)

Features

The Cisco Nexus 5010 switch is a top-of-rack switch that provides Ethernet and Fibre Channel consolidation in a single physical cable. The Fibre Channel over Ethernet (FCoE) protocol is used to consolidate Ethernet and Fibre Channel traffic onto the same physical connection between the server and the switch. As a top-of-rack switch, all the servers in the rack connect to the Cisco Nexus 5010 switch, and it connects to the LAN or SAN.

The Cisco Nexus 5010 switch is a part of a family of switches that provide 10-Gigabit Ethernet and FCoE ports and both 10-Gigabit Ethernet and native 4-, 2-, or 1-Gbps Fibre Channel ports. The switches provide consolidated I/O connectivity to both production Ethernet LANs and Fibre Channel SANs in a cost-effective, high-performance, low-latency Ethernet switch.

The Cisco Nexus 5010 switch has the following features:

- One slot on the back of the switch for an optional uplink Generic Expansion Module [GEM]. The following modules can be inserted into this slot: N5K-M1404, N5K-M1600 and N5K-M1008.
- There are 20 to 28 ports on the back of the switch depending on which GEM is installed. Twenty ports on Cisco Nexus 5010 switch belong to the base switch. Additionally, you can insert a module with six or eight ports.
- Two slots on the front of the switch for hot swap-capable power supplies.
- Two slots on the front of the switch for fan modules. Each fan module houses six fans. The combination of six fans per module and two modules provides the switch with a total of 12 fans.
- The L1/L2/Mgmt1 ports are not usable. They are disabled at this time

Chassis

The Cisco Nexus 5010 chassis is 1 RU, 1.72 inches (4.37 cm) tall, 17.3 inches (43.94 cm) wide, and 30.0 inches (76.2 cm) deep. It is designed to be mounted in a standard 19-inch rack. The switch has two power supplies and two fan modules on the front of the switch. Ports are at the rear of the switch. The airflow is front to back. [Figure 1-42](#) shows the front view of the Cisco Nexus 5010 switch. The airflow is front-to-back, which means you must position the switch with its front end in a cold aisle.

Figure 1-42 Cisco Nexus 5010 Switch Front View

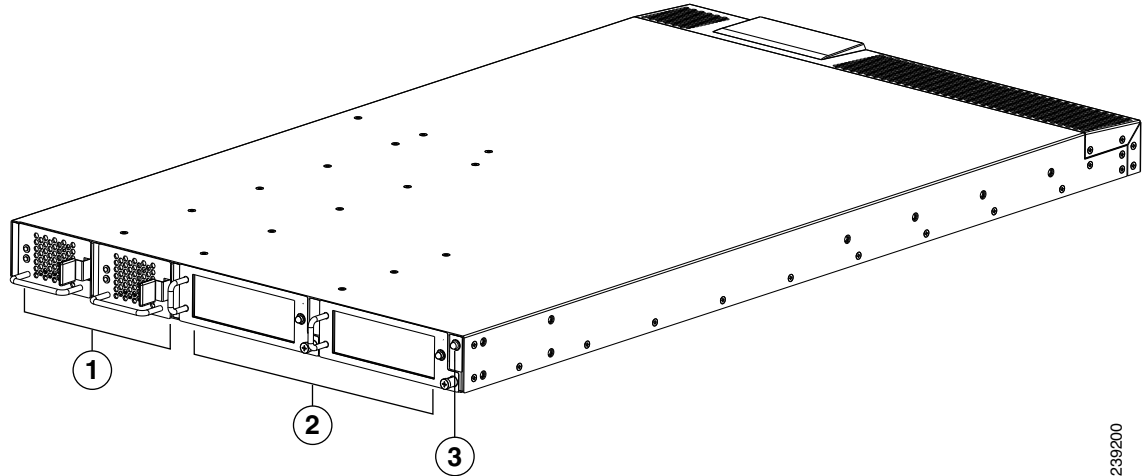

239200

1	Two power supplies	3	System status LED
2	Two fan modules		

The rear of the Cisco Nexus 5010 chassis has 20 fixed 10-Gigabit Ethernet ports, 1 slot for an optional expansion module, an Ethernet connector with 2 cross-connect ports and 2 management ports, a console port, and 2 AC power connectors. [Figure 1-43](#) shows the rear of the Cisco Nexus 5010 switch.

Figure 1-43 Cisco Nexus 5010 Switch Rear View

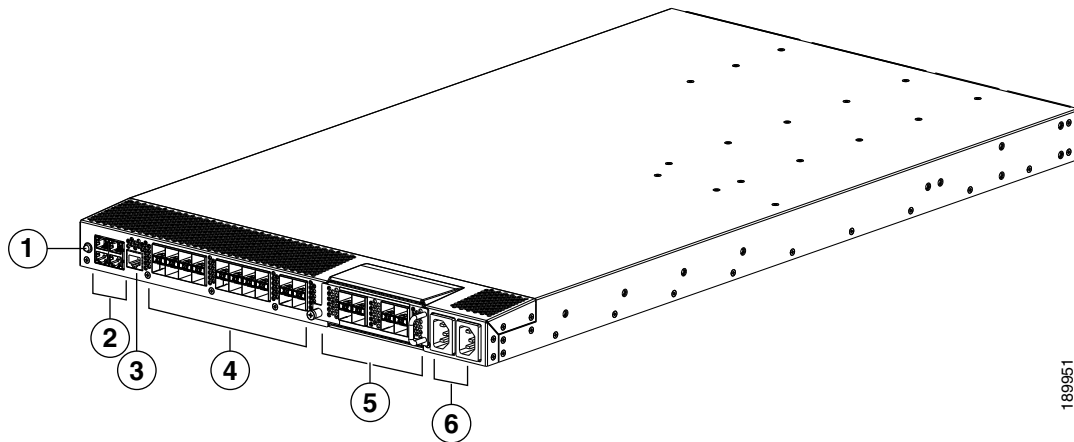

189951

1	System status LED	4	20 fixed 10-Gigabit Ethernet ports
2	Two cross-connect ports on the left (top and bottom) and two network management ports on the right (top and bottom)	5	Expansion modules
3	Console port	6	AC power connectors

The cross-connect and network-management ports are in a 2 x 2 stacked set of RJ-45 jacks. [Figure 1-44](#) shows a close-up view of the these ports.

Figure 1-44 Cross-Connect and Network-Management Ports

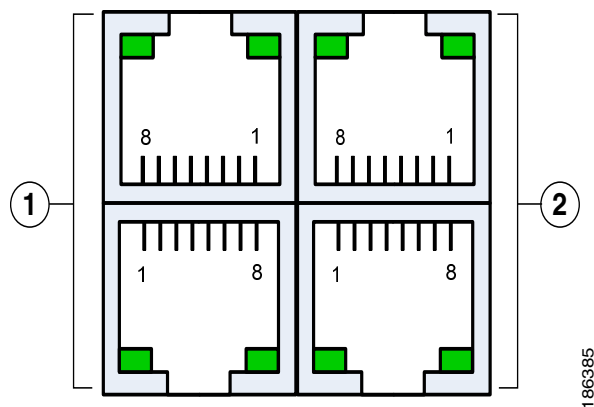

1	Internal cross connect ports	2	Network management ports
---	------------------------------	---	--------------------------

For information on the Ethernet LEDs, see [Table D-3 on page D-4](#).

Expansion Modules

Expansion modules allow Cisco Nexus 5000 Platform switches to be configured as cost-effective, 10-Gigabit Ethernet switches and as I/O consolidation platforms with native Fibre Channel connectivity. The Cisco Nexus 5010 switch has one slot for an optional uplink Generic Expansion Module (GEM). The following modules can be inserted in this slot: N5K-M1404, N5K-M1600, N5K-M1008 and N5K-M1060.

- N5K-M1404 provides 4 10G SFP+, and 4 Fibre Channel 4-, 2-, or 1-Gbps SFP-based uplink connections. The 10-Gigabit Ethernet ports are encryption capable.
- M5K-M1600 provides 6 10G SFP+ based uplink connections.
- N5K-M1008 provides 8 4-, 2-, or 1-Gbps Fibre Channel, SFP based uplink connection.
- N5K-M1060 provides 6 8-, 4-, 2-, or 1-Gbps line rate Fibre Channel, SFP+ based uplink connections.

The chassis supports hot swapping of the expansion modules.

This section includes the following topics:

- [N5K-M1404 Generic Expansion Module, page 1-44](#)

- [N5K-M1600 Generic Expansion Module, page 1-45](#)
- [N5K-M1008 Generic Expansion Module, page 1-46](#)
- [N5K-M1060 Generic Expansion Module, page 1-47](#)

N5K-M1404 Generic Expansion Module

The N5K-M1404 GEM supports four SFP+ transceiver modules and four 4-, 2-, or 1-Gbps Fibre Channel transceivers. The N5K-M1404 Fibre Channel plus Ethernet expansion module is a field-replaceable unit (FRU). [Figure 1-45](#) shows the Fibre Channel plus Ethernet expansion module.

Figure 1-45 N5K-M1404 Generic Expansion Module

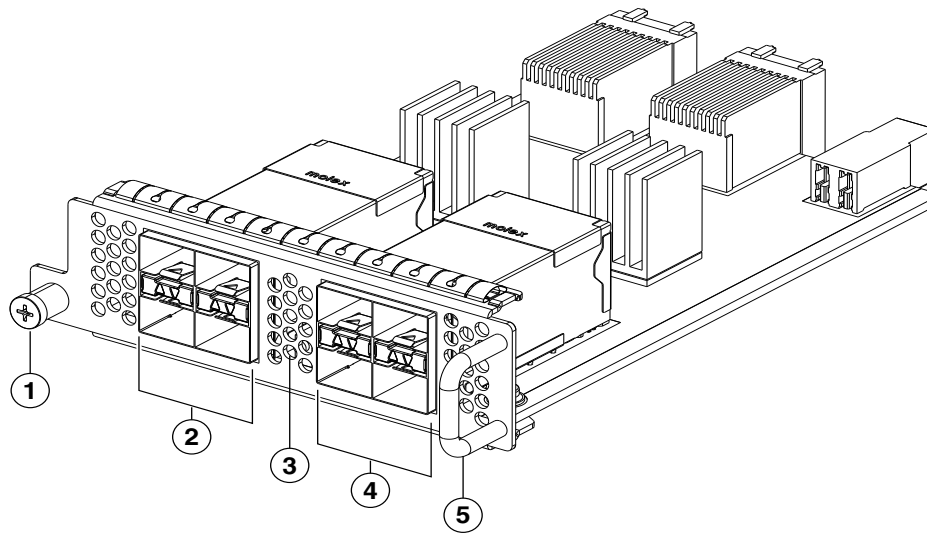

1	Captive screw	4	Four 4-, 2-, and 1- Gbps Fibre Channel ports
2	Four 10-Gigabit Ethernet ports	5	Handle
3	Status LED		

[Figure 1-7](#) shows how ports are numbered on the module.

Figure 1-46 Front of the N5K-M1404 GEM

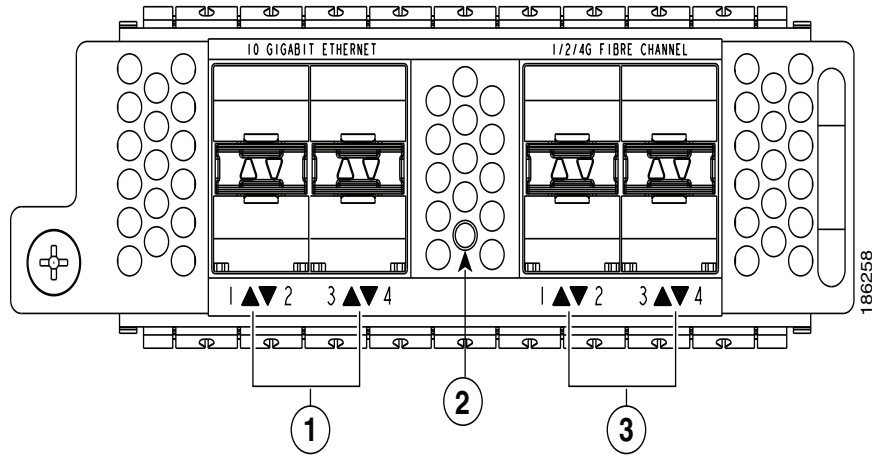

1	Port numbering for the four 10-Gigabit Ethernet ports	3	Port numbering for the four 4-, 2-, or 1- Gbps Fibre Channel ports
2	Status LED		

N5K-M1600 Generic Expansion Module

The N5K-M1600 GEM supports 6 10-Gbps, SFP+ based uplink connections. [Figure 1-47](#) shows the N5K-M1600 GEM.

Figure 1-47 N5K-M1600 GEM

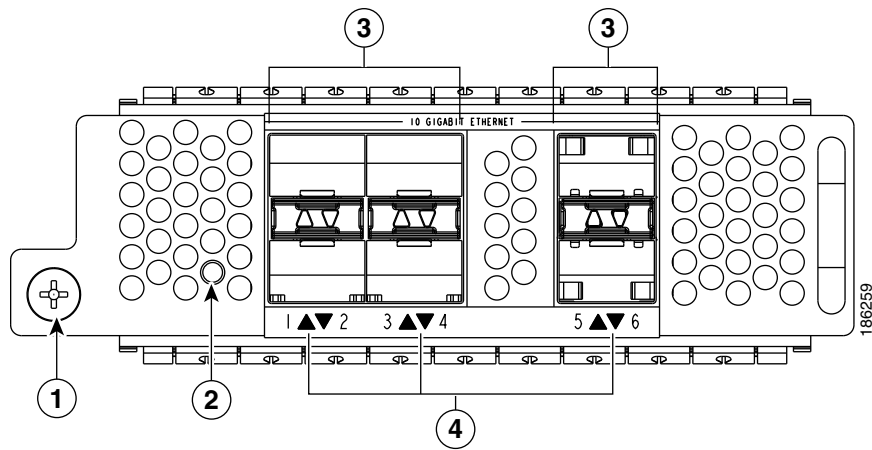

1	Captive screw	3	Six 10-Gbps Ethernet ports
2	Status LED	4	Port numbering for the Ethernet ports (odd numbered ports above even numbered ports)

See [Figure 1-38](#) for an illustration of how ports are grouped and numbered on the Ethernet expansion module.

N5K-M1008 Generic Expansion Module

The N5K-M1008 GEM supports eight 4-, 2-, or 1-Gbps Fibre Channel, SFP-based uplink connections. [Figure 1-48](#) shows the features used to install this module and [Figure 1-49](#) shows how the ports are numbered.

Figure 1-48 N5K-M1008 GEM

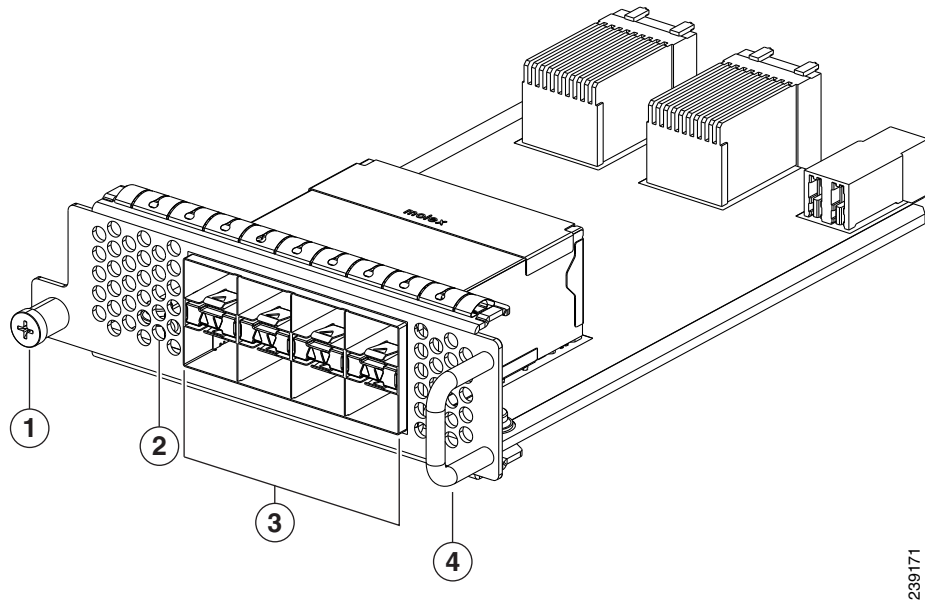

239171

1	Captive screw	3	Eight 4-, 2-, or 1-Gbps Fibre Channel ports
2	Status LED	4	Handle

Figure 1-49 Front View of the N5K-M1008 GEM

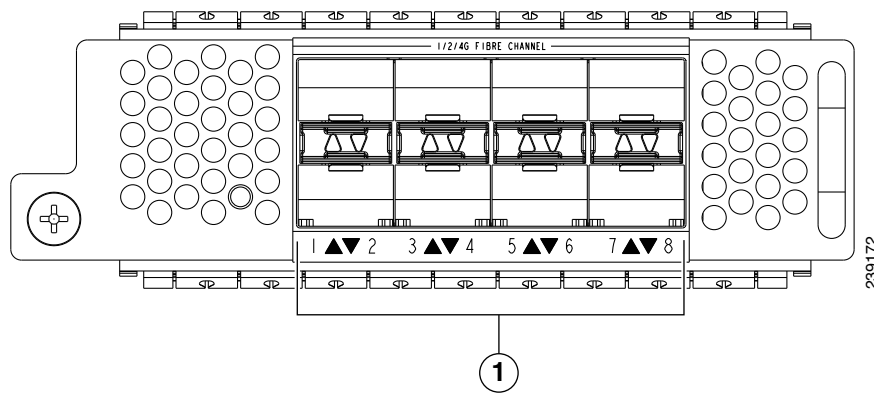

239172

1	Port numbering (odd numbered ports on top and even numbered ports on bottom)	
----------	--	--

N5K-M1060 Generic Expansion Module

The N5K-M1060 expansion module provides six 8-, 4-, 2-, or 1-Gbps line rate Fibre Channel, SFP+ based uplink connections. [Figure 1-50](#) shows this module and the features used to install it.

Figure 1-50 N5K-M1060 GEM

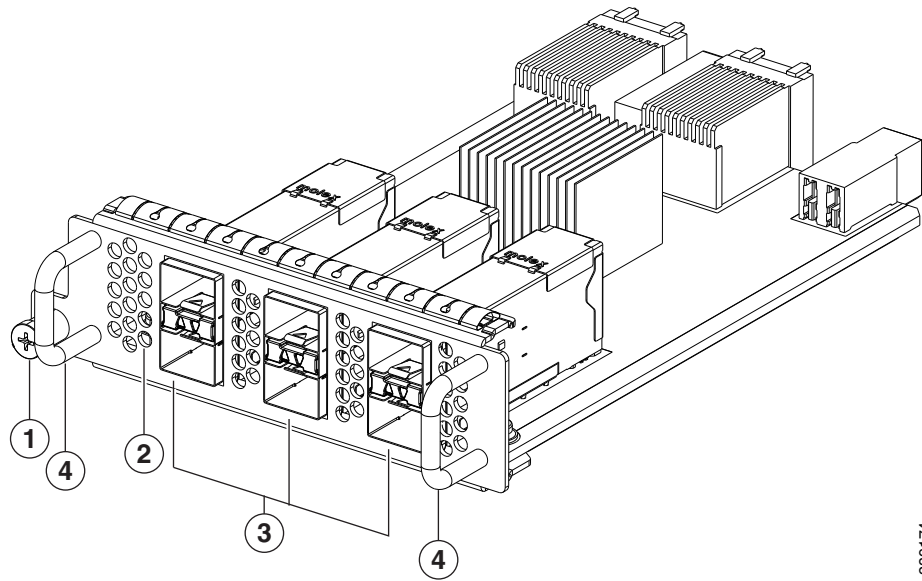

1	Captive screw	3	Six 8-, 4-, 2-, or 1-Gbps Fibre Channel ports
2	Status LED	4	Handle

[Figure 1-51](#) shows how the ports are numbered on this module.

Figure 1-51 Front of the N5K-M1060 GEM

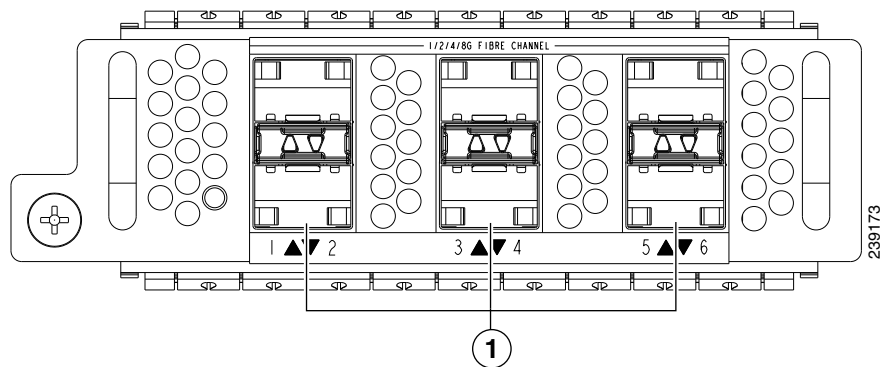

1	Port numbering (odd numbered ports on top and even numbered ports on bottom)		
----------	--	--	--

Ports

Each individual port on the Cisco Nexus 5010 switch is numbered, and groups of ports are numbered based on their function. The ports are numbered top to bottom and left to right.

There are 20 to 28 ports on the Cisco Nexus 5010 switch, depending on which GEM is installed.

The 20 fixed ports form group 1 and are named *1/port_number*. Ports 1 through 16 are unencrypted Ethernet ports. Ports 1 through 8 are 10-Gigabit Ethernet and 1-Gigabit Ethernet-capable ports. Ports 17 through 20 are encryption-capable Ethernet ports.

Group 2 includes the ports in the GEM module. Group 2, ports 1 through 4, are encrypted Ethernet ports. Group 2, ports 5 through 8, are Fibre Channel ports.

Figure 1-52 shows how ports are numbered and grouped by function with the N5K-M1404 GEM installed.

Figure 1-52 Port Numbering of the Cisco Nexus 5010 Switch with the N5K-M1404 GEM

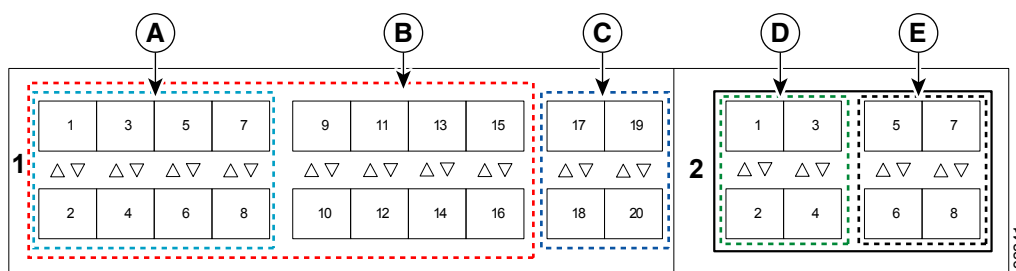

A	Group 1, ports 1 through 8: 10-Gigabit Ethernet and 1-Gigabit Ethernet-capable unencrypted ports	D	Group 2, ports 1 through 4: Encrypted Ethernet ports
B	Group 1, ports 1 through 16: Unencrypted Ethernet ports	E	Group 2, ports 5 through 8: Fibre Channel ports
C	Group 1, ports 17 through 20: Encrypted Ethernet ports		

Figure 1-53 shows how ports are numbered and grouped by function with the N5K-M1600 GEM installed.

Figure 1-53 Port Numbering of the Cisco Nexus 5010 Switch with the N5K-M1600 GEM

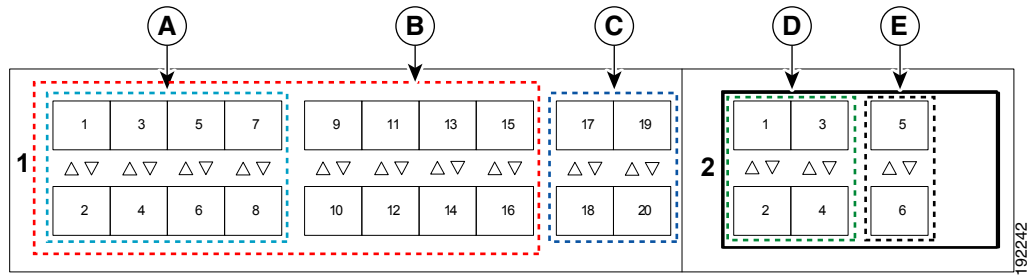

A	Group 1, ports 1 through 8: 10-Gigabit Ethernet and 1-Gigabit Ethernet-capable unencrypted ports	D	Group 2, ports 1 through 4: Encrypted Ethernet ports
B	Group 1, ports 1 through 16: Unencrypted Ethernet ports	E	Group 2, ports 5 and 8: Unencrypted Ethernet ports
C	Group 1, ports 17 through 20: Encrypted Ethernet ports		

Figure 1-54 shows how ports are numbered and grouped by function with the N5K-M1008 GEM installed.

Figure 1-54 Port Numbering of the Cisco Nexus 5010 Switch with the N5K-M1008 GEM

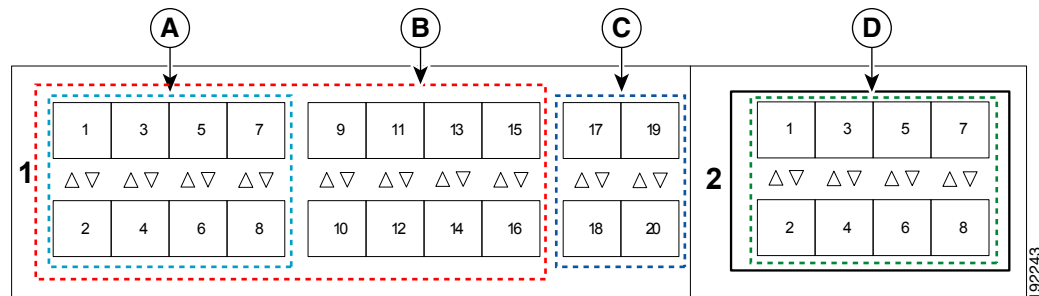

A	Group 1, ports 1 through 8: 10-Gigabit Ethernet and 1-Gigabit Ethernet capable unencrypted ports	C	Group 1, ports 17 through 20: Encrypted Ethernet ports
B	Group 1, ports 1 through 16: Unencrypted Ethernet ports	D	Group 2, ports 1 through 8: Fibre Channel ports

Power Supplies

The Cisco Nexus 5010 switch uses a front-end power supply with front-to-back (port-side exhaust) airflow. The chassis has slots for two power supplies. Two power supplies can be used for redundancy, but the Cisco Nexus 5010 switch is fully functional with one power supply. Figure 1-55 shows the power supply, which has two LEDs: one for power status and one for failure condition.

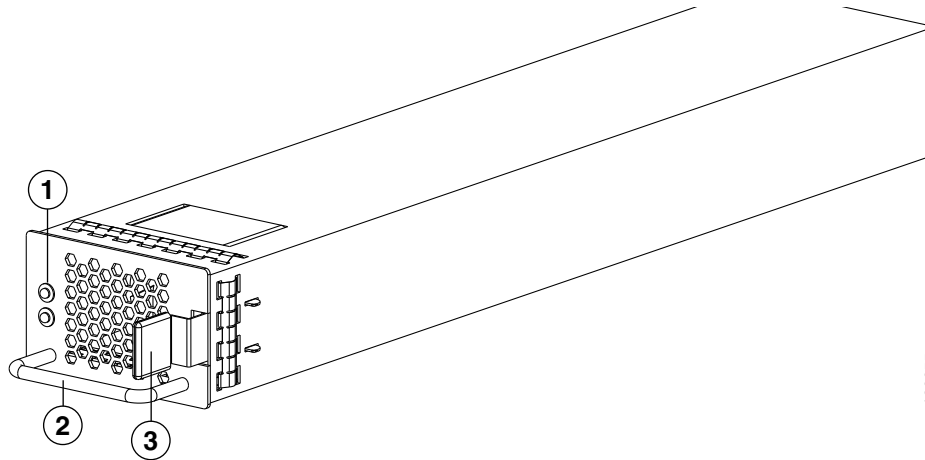
Figure 1-55 Power Supply for the Cisco Nexus 5010 Switch

1	FAIL (top) and OK (bottom) LEDs	3	Release latch
2	Handle		

For information on the LEDs see [Table D-1 on page D-2](#). To see what combinations of these LEDs indicate, see [Table D-2 on page D-3](#).

If you have one power supply installed in the chassis, but the other power supply slot is empty, you should use a blank panel to cover the empty slot. [Figure 1-56](#) shows a blank power supply panel.

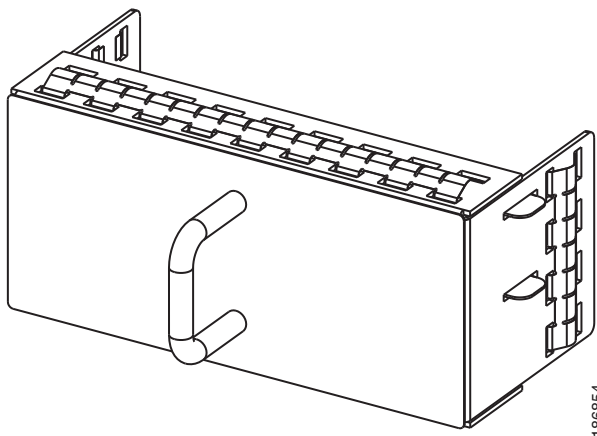
Figure 1-56 Blank Power Supply Panel

Fan Modules

The Cisco Nexus 5010 switch has slots for two fan modules. Each fan module houses six fans and each uses front-to-back (port-side exhaust) airflow. If you insert 2 fan modules (with 6 fans in each module), your switch will have a total of 12 fans. [Figure 1-26](#) shows the fan module.

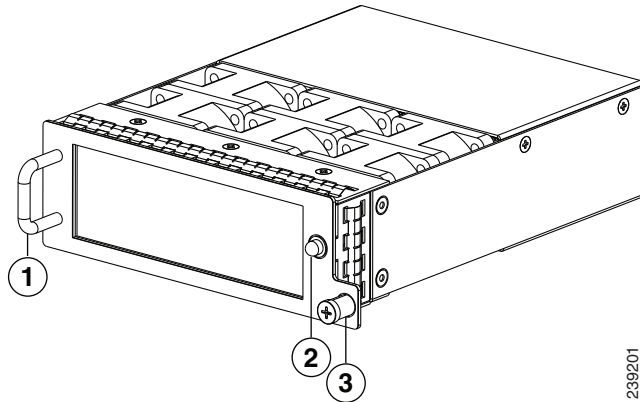
Figure 1-57 Cisco Nexus 5010 Fan Module

1	Handle	3	Captive screw
2	Fan module LED		

The bicolor fan module LED indicates the fan tray health. Green indicates normal operation, while amber indicates a fan failure.

Transceivers

The Cisco Nexus 5010 switch supports both SFP+ Ethernet transceivers and SFP Fibre Channel transceivers.

This section includes the following topics:

- [SFP+ Transceivers, page 1-51](#)
- [SFP+ Copper Cables, page 1-52](#)
- [SFP Fibre Channel Transceivers, page 1-52](#)

SFP+ Transceivers

The enhanced SFP+ 10-Gigabit Ethernet transceiver module is a bidirectional device with a transmitter and receiver in the same physical package. It has a 20-pin connector on the electrical interface and duplex LC connector on the optical interface. The Cisco Nexus 5010 switch supports the following SFP+ optical transceivers:

- SR
- LR (for uplink only)

Table 1-11 SFP+ Transceivers

Model	Description
SFP-10G-SR	10-Gigabit Ethernet—Short range SFP+ module
SFP-10G-LR	10-Gigabit Ethernet—Long range SFP+ module

SFP+ Copper Cables

Copper cables are available for use with the 10-Gigabit Ethernet SFP+ module (see [Table 1-12](#)). The cables come in the following lengths:

- 1 m, 30 AWG
- 3 m, 28–30 AWG
- 5 m, 26–28 AWG

Table 1-12 SFP+ Copper Cables

Model	Description
SFP-H10GB-CU1M	10GBASE-CU SFP+ cable (1 meters)
SFP-H10GB-CU3M	10GBASE-CU SFP+ cable (3 meters)
SFP-H10GB-CU5M	10GBASE-CU SFP+ cable (5 meters)

SFP Fibre Channel Transceivers

The Cisco Nexus 5010 switch supports the multimode 850-nm 4-Gbps SFP with 150-m reach (see [Table 1-13](#)).

Table 1-13 SFP Fiber Channel Transceivers

Model	Description
DS-SFP-FC4G-SW	4-Gbps Fibre Channel-SW SFP, LC
DS-SFP-FC4G-LW	4-Gbps Fibre Channel-LW SFP, LC, (10-km reach)