



PIX 506/506E

This chapter describes how to install a PIX 506/506E, and includes the following sections:

- [PIX 506/506E Product Overview, page 3-1](#)
- [Installing the PIX 506/506E, page 3-3](#)
- [Connecting a Power Supply Module to the PIX 506/506E, page 3-4](#)
- [Removing and Replacing the PIX 506/506E Chassis Cover, page 3-6](#)
- [Replacing a Lithium Battery, page 3-7](#)



Note

The PIX 506 and the PIX 506E are the same except the PIX 506E has a faster processor and a different power supply.

PIX 506/506E Product Overview

This section describes the PIX 506/506E front and rear panels and the panel LEDs.

[Figure 3-1](#) shows the front view of the PIX 506/506E.

Figure 3-1 PIX 506/506E Front Panel



Figure 3-2 shows the rear view of the PIX 506/506E.

Figure 3-2 PIX 506/506E Rear Panel

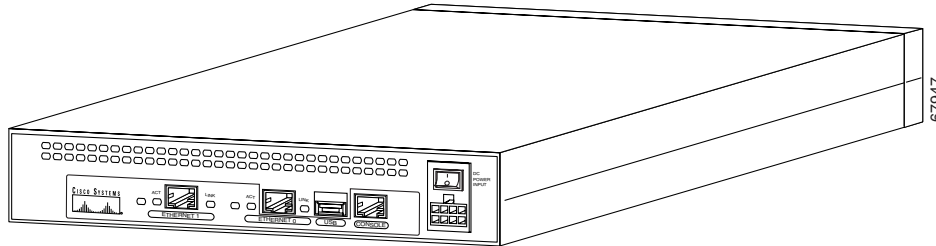

Figure 3-3 shows the PIX 506/506E front panel LEDs.

Figure 3-3 PIX 506/506E Front Panel LEDs

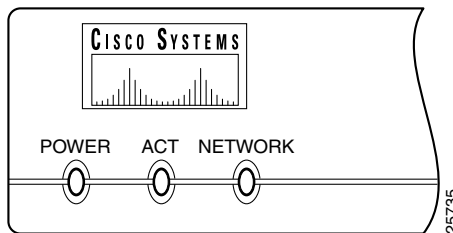

Table 3-1 lists the states of the PIX 506/506E front panel LEDs.

Table 3-1 PIX 506/506E Front Panel LEDs

LED	Color	State	Description
POWER	Green	On	The unit has power.
ACT	Green	Flashing	Active indicator—On when the software image has been loaded on the security appliance.
NETWORK	Green	Flashing	On when at least one network interface is passing traffic.

Figure 3-4 shows the PIX 506/506E rear panel LEDs.

Figure 3-4 PIX 506/506E Rear Panel LEDs

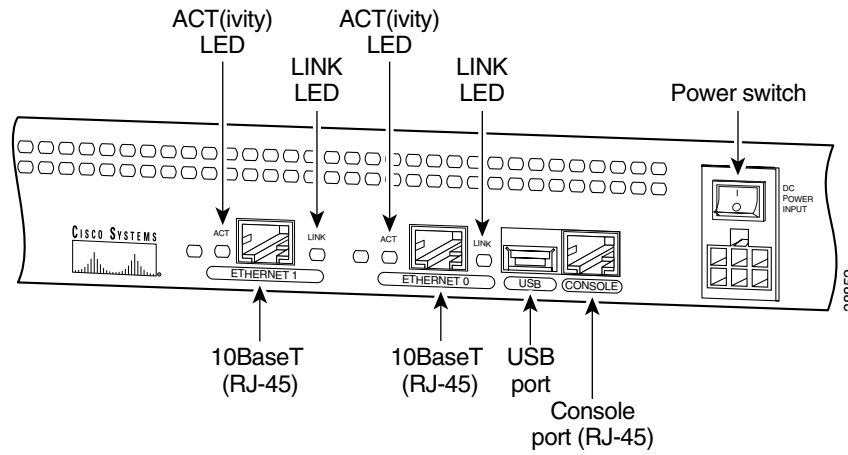

Table 3-2 lists the states of the PIX 506/506E rear panel LEDs.

Table 3-2 PIX 506/506E Rear Panel LEDs

LED	Color	State	Description
ACT	Green	On	Shows network activity.
LINK	Green	On	Shows that data is passing on the network to which the connector is attached.

The USB port at the left of the Console port is not used.

Installing the PIX 506/506E

Place the PIX 506/506E on a flat, stable surface. The PIX 506/506E is not rack mountable.

To install the PIX 506/506E, perform the following steps:

- Step 1** Connect the cable so that you have either a DB-9 or DB-25 connector on one end as required by the serial port for your computer, and the other end is the RJ-45 connector.



Note Use the RJ-45 Console port to connect a computer to enter configuration commands. Locate the serial cable from the accessory kit. The serial cable assembly consists of a null modem cable with RJ-45 connectors, and one DB-9 connector and one DB-25 connector.

- Step 2** Connect the RJ-45 connector to the PIX 506/506E and connect the other end to the serial port connector on your computer (see [Figure 3-7](#)).

Figure 3-5 PIX 506/506E Serial Console Cable

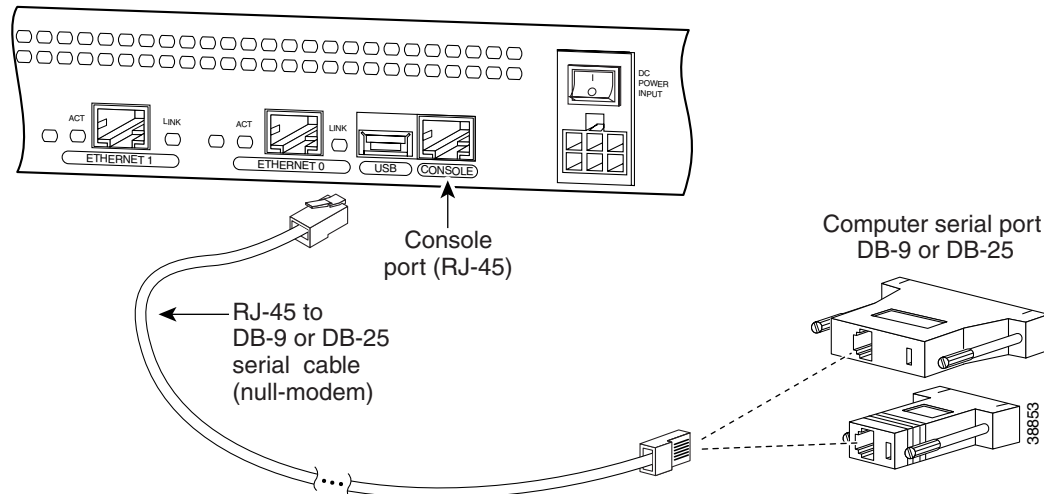

- Step 3** Connect the inside network cable to the interface connector marked ETHERNET 0 or ETHERNET 1.



Note The inside or outside network connections can be made to either interface port on the PIX 506/506E.

- Step 4** Connect the outside network cable to the remaining Ethernet port.

Connecting a Power Supply Module to the PIX 506/506E

This section describes how to connect the power supply module to the PIX 506/506E. Use this information in conjunction with the *Regulatory Compliance and Safety Information* document.

The PIX 506/506E uses an external AC to DC power supply. Power is supplied to the PIX 506/506E by connecting the power supply to the back of the security appliance and connecting a separate AC power cord to the power supply.

Figure 3-6 displays the cable connection from the power supply to the PIX 506, and displays the AC power cord connector (at the opposite end of the power supply).

Figure 3-6 Connecting the Power Supply Module to the PIX 506 6-Pin Connector

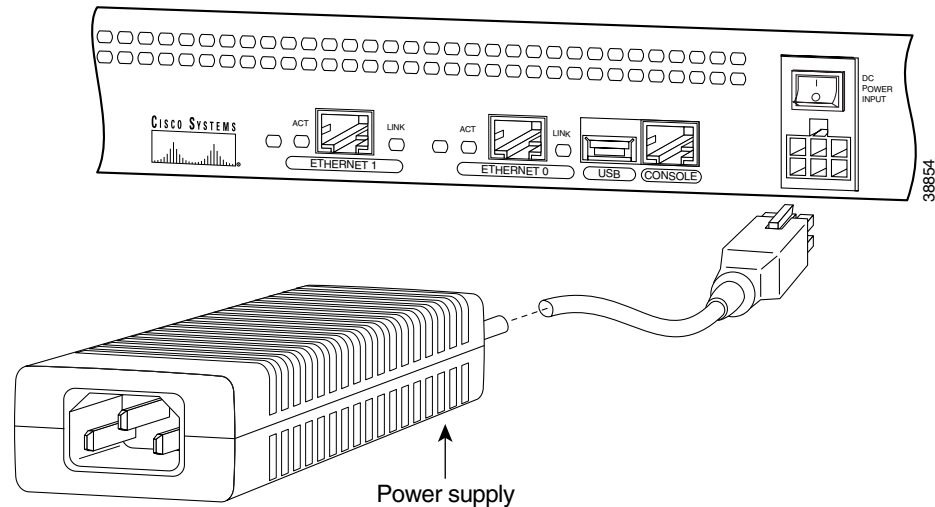
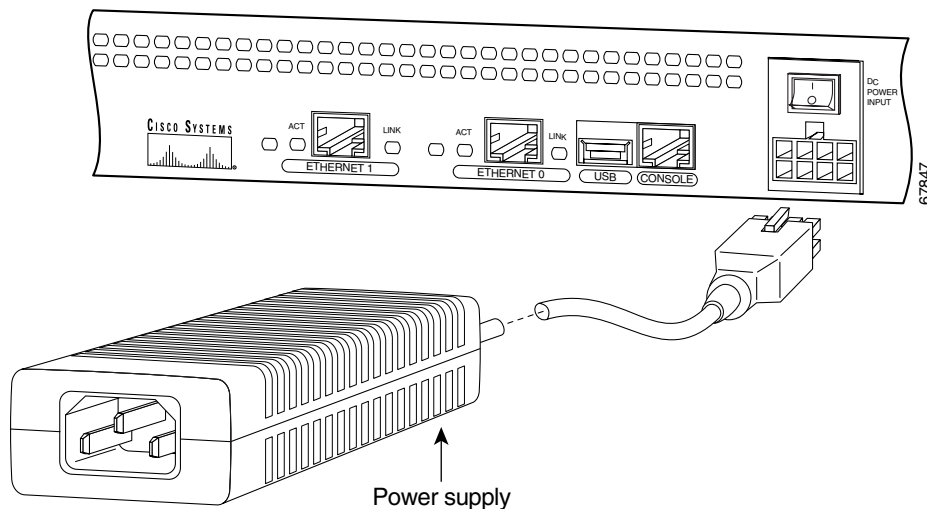

Figure 3-7 displays the cable connection from the power supply to the PIX 506E, and displays the AC power cord connector (at the opposite end of the power supply).

Figure 3-7 Connecting the Power Supply Module to the PIX 506E 8-Pin Connector



Complete these steps to connect the power supply module:

-
- Step 1** Place the PIX 506/506E on a flat, stable surface. The PIX 506/506E is not rack mountable.
 - Step 2** Connect the power supply to the back of the PIX 506/506E. See [Figure 3-6](#) for the PIX 506 and [Figure 3-7](#) for the PIX 506E.
 - Step 3** When you are ready to start the PIX 506/506E, power on the unit from the switch at the rear of the unit.
-

Removing and Replacing the PIX 506/506E Chassis Cover

This section describes how to remove and replace the chassis cover from the PIX 506/506E. This section includes the following topics:

- [Removing the Chassis Cover, page 3-6](#)
- [Replacing the Chassis Cover, page 3-7](#)

Removing the Chassis Cover

Complete the following to remove the chassis cover:



Note

Removing the chassis cover does not affect your Cisco warranty. Upgrading the PIX security appliance does not require any special tools and does not create any radio frequency leaks.

Step 1 Read the *Regulatory Compliance and Safety Information* document.

Step 2 Power off the security appliance and unplug the power cord.



Warning

Before working on a system that has an On/Off switch, turn OFF the power and unplug the power cord.

Step 3 Disconnect the network interface cables.

Step 4 Remove the two screws from the back of the chassis (see [Figure 3-8](#)).

Figure 3-8 Removing PIX 506/506E Chassis Cover Screws

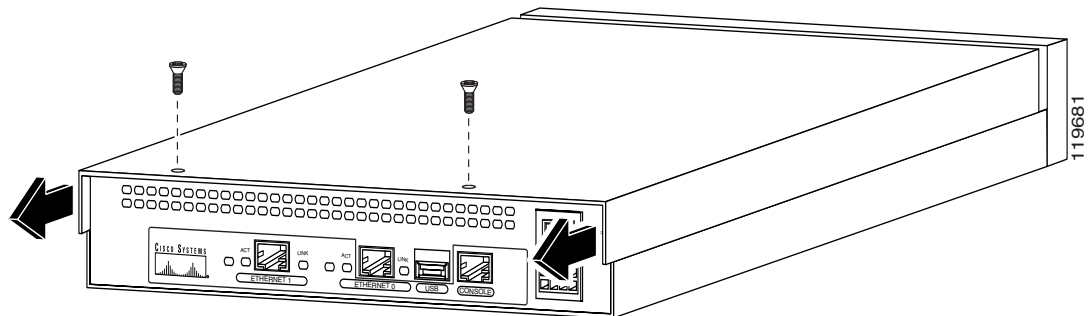

Step 5 With the rear panel facing you, slide the chassis cover back and then lift it up off the bottom section, as shown in [Figure 3-8](#).

Replacing the Chassis Cover

**Caution**

Do not operate PIX security appliances without the chassis cover installed. The chassis cover protects the internal components, prevents electrical shorts, and provides proper air-flow for cooling the electronic components.

Complete the following to replace the chassis cover:

-
- Step 1** Place the chassis on a secure surface with the front panel facing you.
 - Step 2** Hold the chassis cover so the tabs at the rear of the cover are aligned with the bottom of the chassis.
 - Step 3** Lower the front of the cover onto the chassis, making sure that the side tabs of the cover fit under the side panels of the chassis.
 - Step 4** Slide the chassis cover toward the front, making sure that the cover tabs fit under the back panel, and the back panel tabs fit under the chassis cover.
 - Step 5** Secure the chassis cover with the screws you set aside earlier.
 - Step 6** Reconnect the network interface cables.
 - Step 7** Place the PIX 506/506E on a flat, stable surface. The PIX 506/506E is not rack mountable.
 - Step 8** Reconnect the power cord and power on the security appliance.
-

Replacing a Lithium Battery

The PIX 506/506E has a lithium battery on its main circuit board (see [Figure 3-9](#)). This battery has an operating life of about ten years. When the battery loses its charge, the PIX security appliance cannot function. The battery is a field-replaceable unit (FRU). You can use a standard 3V lithium battery to replace the used battery.

Figure 3-9 PIX 506/506E Lithium Battery Location

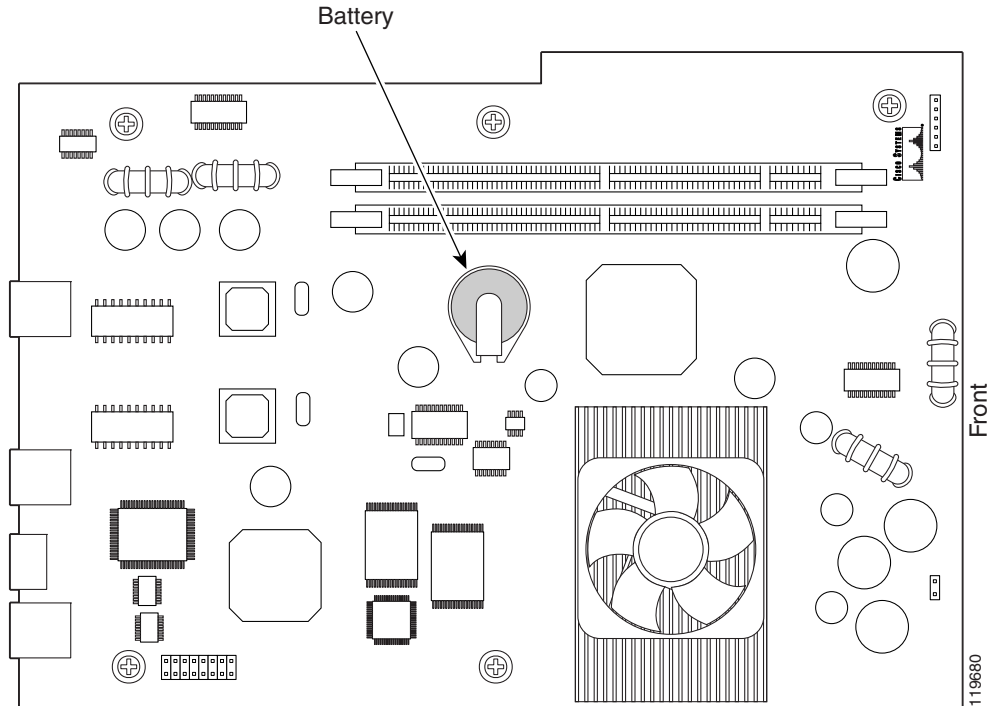
**Warning**

Danger of explosion exists if the lithium battery is incorrectly replaced. Replace only with the same or equivalent type recommended by the manufacturer. Dispose of used batteries according to the manufacturer's instructions.

To replace the lithium battery, perform the following steps:

- Step 1** Remove the chassis cover as described in the [“Removing the Chassis Cover”](#) section on page 3-6.
- Step 2** Use a flathead screwdriver to slide the battery out of the metal clip on the circuit board (see [Figure 3-9](#)).
- Step 3** Place the used battery aside and replace it with a new battery. Install the new battery writing side up.
- Step 4** The battery snaps into place as you slide it into the battery slot.
- Step 5** Replace the chassis cover by lining up the cover tabs with the bottom panel tabs, and sliding the chassis cover back into the side and front panel slots on the chassis.
- Step 6** Replace the chassis cover as described in the [“Replacing the Chassis Cover”](#) section on page 3-7.