



# CHAPTER 1

## Overview

---

This document provides information to install and configure the components located near each door of a Cisco Physical Access Control system.

This document includes the following information:

- [System Overview, page 1-1](#)
  - [The Cisco Physical Access Gateway, page 1-2](#)
  - [Support for Multiple Cisco Physical Access Gateways, page 1-3](#)
  - [Cisco Physical Access Manager, page 1-3](#)
- [Optional Expansion Modules, page 1-6](#)
  - [CAN Bus Connections for Optional Modules, page 1-8](#)
- [Installation and Configuration Summary, page 1-9](#)
- [Power Options and Requirements, page 1-10](#)
- [Mounting a Gateway or Optional Module, page 1-11](#)

## System Overview

Cisco Physical Access Control is a comprehensive solution of hardware and software components, connected through an IP network as shown in [Figure 1-1](#).

**Figure 1-1** *Cisco Physical Access Control: System Overview*

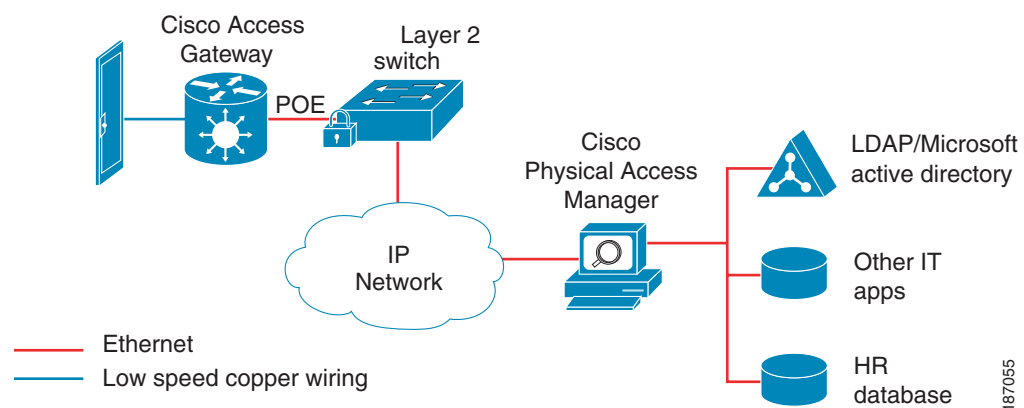

## The Cisco Physical Access Gateway

A Cisco Physical Access Gateway is installed near each door to provide processing and control for the connected door hardware, such as card readers, locks, and other input and output devices. This architecture allows access control to be deployed incrementally, door by door, eliminating the central panel and simplifying system design, wiring, and planning.

The Gateway is required, and can control up to two doors. Each Gateway supports the following:

**Table 1-1** *Cisco Physical Access Gateway Features and Benefits*

Feature	Benefit
250,000 cardholder cache and a 150,000 Transaction buffer	Door continues to function in case network connectivity is lost
Web server built in	Simplifies configuration and monitoring
All communication is 128 Bit AES encrypted	Protects credentials, preserves security
Device pre-provisioning using network services	Simplifies deployment
Plug & Play support	Modules can be added or deleted without disrupting service

If additional connections are required, you can connect up to 15 optional modules using a three-wire Controller Area Network (CAN) bus. These modules can be added or removed without affecting the operation of the system or other modules. See [Optional Expansion Modules, page 1-6](#) for more descriptions of the available modules.



**Note**

The modules are connected using the CAN1 interface. The CAN2 interface is not supported in this release.

### Related Documentation

For installation and configuration instructions, see [Chapter 2, “Installing and Configuring the Cisco Physical Access Gateway”](#). See the *User Guide for Cisco Physical Access Manager* for advanced configuration and management of the access control components.

## Support for Multiple Cisco Physical Access Gateways

A Cisco Physical Access Gateway is installed for each door, and connected to the IP network using an Ethernet connection, as shown in [Figure 1-2](#). This network connection provides communication with the Cisco Physical Access Manager for advanced configuration, and management with the other Gateways in the system. If the network connection is lost, the Gateway continues to provide access control functionality for the connected door devices.

**Figure 1-2** Multiple Cisco Physical Access Gateways

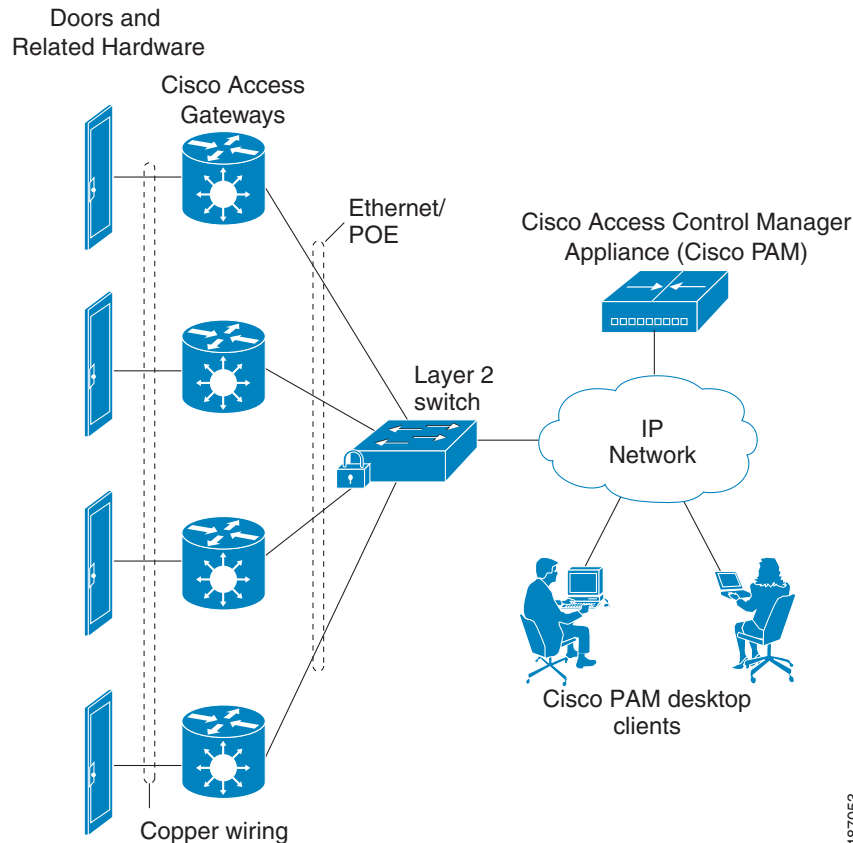

**Note**

See [Power Options and Requirements, page 1-10](#) for more information on support for Power over Ethernet (PoE).

## Cisco Physical Access Manager

The Cisco Physical Access Manager appliance (Cisco PAM) is a hardware and software solution that provides advanced configuration, monitoring, and report generation for the entire system. Each Cisco Physical Access Gateway is connected to the Cisco PAM appliance over an Ethernet-based IP network, as shown in [Figure 1-2](#) on [page 1-3](#). A Java-based desktop application is installed on a PC connected to the network, and used to configure and monitor the system, as shown in [Figure 1-3](#).

**Figure 1-3** *Configuring and Monitoring Using the Cisco Physical Access Manager*

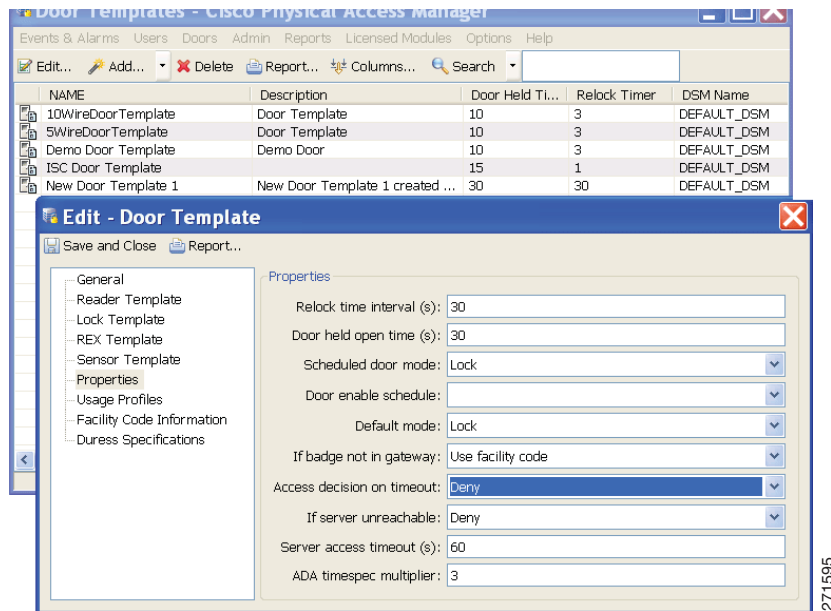

Cisco PAM Configuration Interface

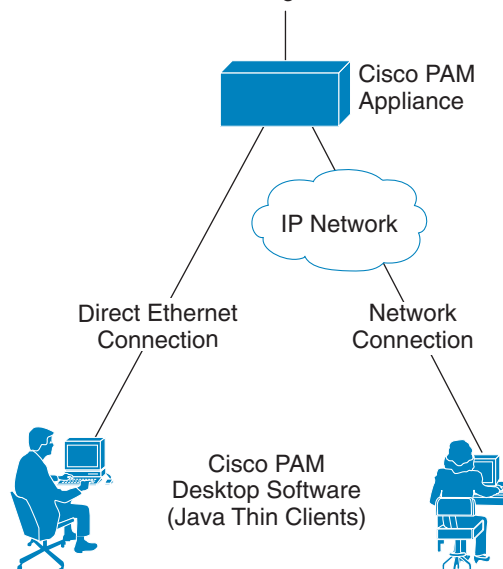

The Cisco PAM appliance includes the following main features:

- 1 RU appliance
- Java thin client architecture
- Policy support: two-door, anti-passback
- Report generator (canned & custom)
- Badge design & enrollment
- Microsoft Active Directory integration
- Fine grained user rights

- Global I/O
- Device pre-provisioning
- Capacity & feature licenses
- IT data integration
- Warm standby high availability
- Audit trails

### Related Documentation

For more information on the Cisco PAM appliance, including installation and configuration instructions, see the *User Guide for Cisco Physical Access Manager*.



**Table 1-1** Main Features of the Cisco Physical Access Control Modules

Gateway	Cisco Reader Module	Cisco Input Module	Cisco Output Module
<ul style="list-style-type: none"> <li>• Mandatory module.</li> <li>• Connects up to two doors using the 10 pin Weigand reader port, which can be configured as two five-pin ports.</li> <li>• Connects up to 15 optional expansion modules using a three-wire CAN bus.<sup>1</sup></li> <li>• Power-over-Ethernet (POE) or 12 through 24V DC</li> <li>• Two Ethernet ports</li> <li>• Three output ports: Form C contacts rated at 5A 30VDC</li> <li>• Three supervised input ports<sup>2</sup></li> <li>• Tamper &amp; Power Fail inputs (can be configured as additional unsupervised inputs)</li> <li>• One RS-485 serial port (not supported in this release).</li> </ul>	<ul style="list-style-type: none"> <li>• Requires connection to an Access Gateway using a three-wire CAN bus.</li> <li>• Connects up to two doors using the 10 pin Weigand reader port, which can be configured as two 5 pin ports.</li> <li>• Power: 12 through 24V DC</li> <li>• Three output ports: Form C contacts rated at 5A 30VDC</li> <li>• Three supervised input ports</li> <li>• Tamper &amp; Power Fail inputs (can be configured as additional unsupervised inputs)</li> <li>• One RS-485 serial port (not supported in this release).</li> </ul>	<ul style="list-style-type: none"> <li>• Requires connection to an Access Gateway using a three-wire CAN bus.</li> <li>• 10 supervised input ports</li> <li>• Example inputs are: Push button switches, Glass Break sensors, or any contact closure input.</li> <li>• Power: 12 through 24V DC</li> <li>• Tamper &amp; Power Fail inputs (can be configured as additional unsupervised ports)</li> </ul>	<ul style="list-style-type: none"> <li>• Requires connection to an Access Gateway using a three-wire CAN bus.</li> <li>• 8 output ports: Form C contacts rated at 5A 30VDC</li> <li>• Example outputs are: lights, LEDs, or any contact closure output circuit.</li> <li>• Power: 12 through 24V DC</li> <li>• Tamper &amp; Power Fail inputs (can be configured as additional unsupervised ports)</li> </ul>

1. The modules are connected using the CAN1 interface. The CAN2 interface is not supported in this release.

2. A supervised input supports four states: normal, alarm, open and short. An unsupervised input only indicates normal or alarm.

## CAN Bus Connections for Optional Modules

The optional modules are connected to a Cisco Physical Access Gateway using a CAN bus connection, as shown in [Figure 1-5](#).

**Figure 1-5** CAN Bus Wiring

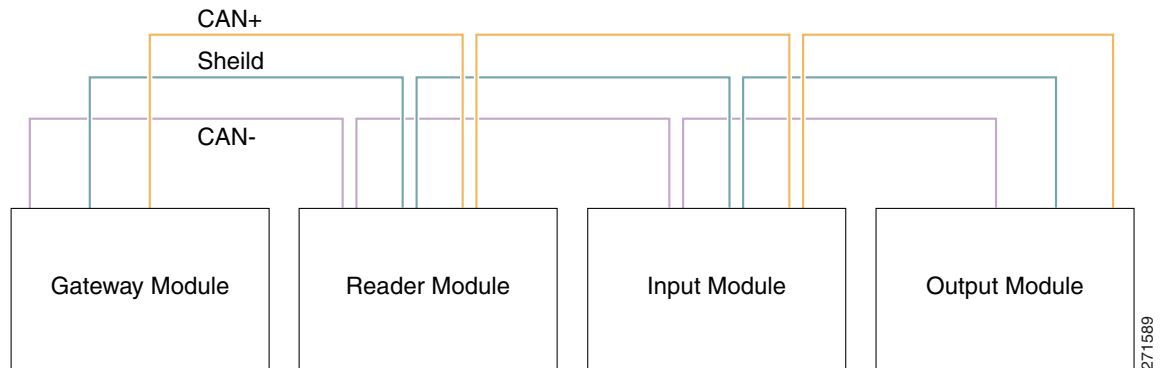

The CAN bus must adhere to the following rules:

- The maximum length for the CAN bus is 1320 feet (400 Metres).
- The last device in a CAN bus must be terminated by setting the CAN terminator switch to ON.
  - The CAN terminator switch is included on the Reader, Input and Output modules only (the Gateway is always the first device in the CAN bus).
  - Set the terminator switch to OFF for all other modules in the CAN bus.
  - For the location of the CAN terminator on each device, see the physical port description for that device.
- The Gateway and Reader modules are connected using the CAN1 interface. The CAN2 interface is not supported in this release.



### Related Documentation

See the following chapters for instructions to install the modules and related equipment:

- [Chapter 2, “Installing and Configuring the Cisco Physical Access Gateway”](#)
- [Chapter 3, “Connecting a Cisco Reader Module”](#)
- [Chapter 4, “Connecting a Cisco Input Module”](#)
- [Chapter 5, “Connecting a Cisco Output Module”](#)

# Installation and Configuration Summary

The following steps are an example of the main installation and configuration tasks for a Cisco Physical Access Control system. The exact procedure and order of installation for your system may vary.

- 
- Step 1** Unpack and mount the Cisco Physical Access Gateway.
- Step 2** Unpack and mount optional reader, input or output modules, if necessary.
- Step 3** Connect door readers, input and output devices to the Cisco Physical Access Gateway or optional modules.
- Step 4** Connect power to the Cisco Physical Access Gateway and any optional modules.
- Step 5** Connect an Ethernet cable from a PC to the ETH1 interface on the Gateway module.
- 
-  **Note** To enter the Gateway initial configuration, be sure to connect your PC to the ETH1 port. The ETH0 port is used for network communication.
- 
- Step 6** Open a web browser on your PC and enter `https://192.168.1.42`. This URL opens the web-based configuration page.
- 
-  **Note** Be sure to include the *s* in `https://`. This connects your browser to the secure URL.
- 
- Step 7** Enter the default username and password:
- default username: **gwadmin**
- default password: **gwadmin**
- Step 8** Enter and save the Network settings in the Initial Setup window. See [Configuring and Managing the Gateway Using a Direct Connection, page 2-15](#). Wait until the Gateway resets and the web browser displays the screen *Network Settings Applied*.
- Step 9** Verify the connections to the optional modules, door readers and other input and output devices.
- Step 10** Connect an Ethernet cable from the Gateway ETH0 port to the IP network, and verify IP network connectivity.
- Step 11** Perform additional configuration, verification, and monitoring tasks as described in the *User Guide for Cisco Physical Access Manager*.

# Power Options and Requirements

This section includes the following information:

- [Power Options](#)
- [Current Draw Requirements](#)

## Power Options

[Table 1-2](#) summarizes the power options for each module. The Cisco Physical Access Gateway supports Power over Ethernet (PoE) and DC power. All other modules support DC power only.

- The DC power connections on each module are Voltage In (VIN) and Ground (GND).
- For information on configuring PoE, see the documentation for your network switch. Your switch must support PoE and be properly configured to use this feature with the Cisco Physical Access Gateway.

**Table 1-2** Power Options for the Cisco Physical Access Control Modules

Module	Power over Ethernet (PoE)	12 through 24V DC
Cisco Physical Access Gateway	Supported	Supported
Cisco Reader Module	Not Supported	Supported
Cisco Input Module	Not Supported	Supported
Cisco Output Module	Not Supported	Supported

## Current Draw Requirements

Each Cisco Physical Access Control module requires a minimum amount of available power, as described in [Table 1-3](#). The current draw requirements listed in [Table 1-3](#) account for inefficiencies in power supplies and are to be used for power budgeting. The requirements do not represent actual power usage.

**Table 1-3** Current Draw Requirements for the Cisco Physical Access Control Modules

Module	Current Draw Requirement	Notes
Cisco Physical Access Gateway	1.5A	1.5A is required for the Gateway module only. Add an additional 1A if a reader or lock is attached to the module.
Cisco Reader Module	1A	1A is required for the Reader module only. Add an additional 1A if a reader or lock is attached to the module.
Cisco Input Module	1A	N/A
Cisco Output Module	1A	N/A

# Mounting a Gateway or Optional Module

Each Cisco Physical Access Gateway and optional module includes two mounting brackets and four screws to mount the Gateway to the wall.

## Wall Mounting a Gateway or Optional Module

Figure 1-6 shows the three options for attaching the included wall-mount brackets to a module.

**Figure 1-6** Three Options for Installing Wall Mount Brackets

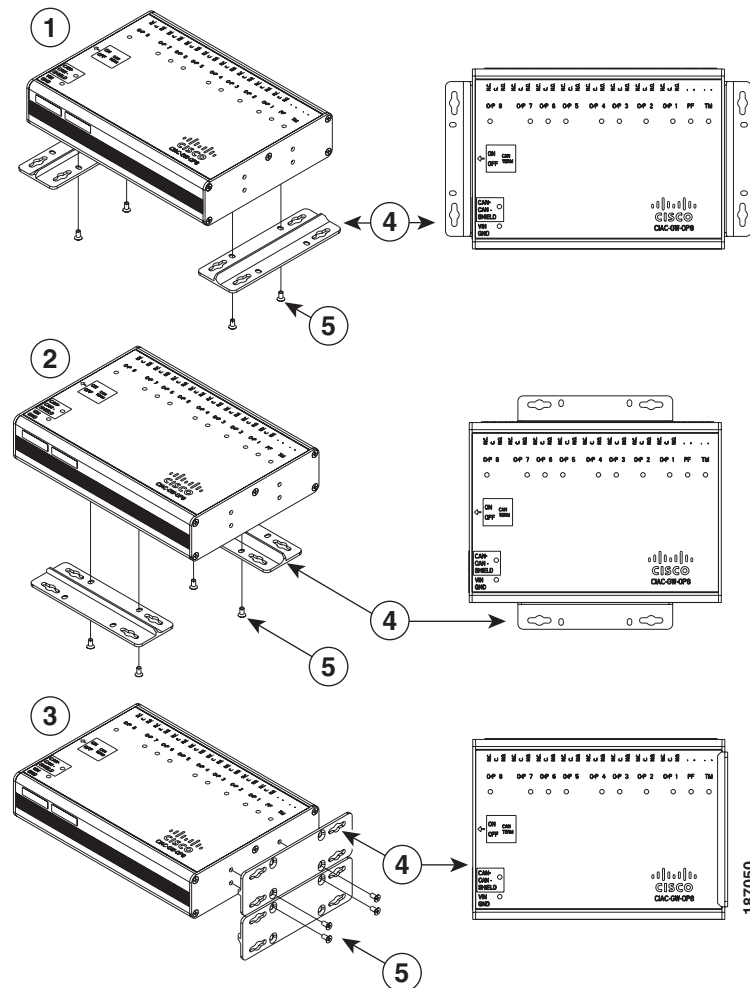

The following items are shown in Figure 1-6:

1	Option 1: Bottom end mounting	4	Mounting Brackets (included)
2	Option 2: Bottom side mounting	5	Screws
3	Option 3: Side mounting		

## Wall Mount Installation Kit Contents

Each module includes a wall mount installation kit that contains the following:

**Table 1-4**      *Wall Mount Installation Kit Contents*

<b>Hardware Item</b>	<b>Quantity</b>
Wall Mount brackets	2
Screws	8