

Configuring Remote Office to Corporate Office Networks

This chapter describes how to configure five remote-office-to-corporate-office networks, which Table 3-1 presents.

Table 3-1 **Sample Networks**

No.	WAN Options	WAN Encapsulation	Routed Protocols	Other Features	Configuration Options
1	Synchronous leased line	High-Level Data Link Control (HDLC)	IP	Dynamic IP routing	<ul style="list-style-type: none"> • Cisco 805 Fast Step software • Command-line interface (CLI)
2	Synchronous leased line	Point-to-Point Protocol (PPP)	IP, IPX	Dynamic IP and IPX routing	<ul style="list-style-type: none"> • Cisco 805 Fast Step software • CLI
3	X.25	X.25	IP, IPX	Dynamic IP and IPX routing	CLI
4	Asynchronous dial-up line	PPP	IP, IPX	<ul style="list-style-type: none"> • Static IP and IPX routes • Easy IP Phase 2 – DHCP server 	<ul style="list-style-type: none"> • Cisco 805 Fast Step software (template option) • CLI

Table 3-1 **Sample Networks (continued)**

No.	WAN Options	WAN Encapsulation	Routed Protocols	Other Features	Configuration Options
5	Frame Relay	Frame Relay	IP, IPX	<ul style="list-style-type: none">• Partially meshed Frame Relay topology• Subinterfaces• Dynamic IP and IPX routing• Easy IP (Phase 2) – Dynamic Host Configuration Protocol (DHCP) relay	<ul style="list-style-type: none">• Cisco 805 Fast Step software• CLI

Note Cisco strongly recommends that inexperienced network administrators use the Cisco 805 Fast Step software to configure sample networks 1, 2, and 5. The Cisco 805 Fast Step software might configure the sample networks differently than is described in this guide.

The Cisco 805 Fast Step software is a Windows 95, Windows NT, and Windows 98 based configuration tool included with the Cisco 805 router. For more information, refer to the Cisco 805 Fast Step CD-ROM.

For more information on configuring your router using the CLI, continue reading this chapter.

Before Configuring Networks

Refer to Table 3-2 to determine what you need to do before configuring each network.

Table 3-2 Before Configuring Networks

Number	WAN Options/ Encapsulation	What You Must Do ^{1, 2}
1	Leased line, HDLC	<ul style="list-style-type: none"> • Network administrators from corporate and remote offices: <ul style="list-style-type: none"> — Set up IP address scheme. — Decide which IP routing protocol to use. • Network administrator from corporate office must order leased line from WAN service provider.
2	Leased line, PPP	<ul style="list-style-type: none"> • Network administrators from corporate and remote offices: <ul style="list-style-type: none"> — Set up IP and IPX address scheme. — Decide which IP routing protocol to use. • Network administrator from corporate office must order leased line from WAN service provider.
3	X.25	<ul style="list-style-type: none"> • Network administrators from corporate and remote offices: <ul style="list-style-type: none"> — Set up IP and IPX address scheme. — Decide which IP routing protocol to use. • Network administrator from corporate office must order X.25 connection from WAN service provider. Also, ask the WAN service provider to provide the following: <ul style="list-style-type: none"> — X.25 address for remote office and corporate office router serial interfaces — X.25 window size — X.25 packet size

Table 3-2 Before Configuring Networks (continued)

Number	WAN Options/ Encapsulation	What You Must Do^{1, 2}
4	Dial-up line, PPP	<ul style="list-style-type: none">• Network administrators from corporate and remote offices:<ul style="list-style-type: none">— Set up IP and IPX address scheme.— Decide which IP routing protocol to use.— Decide which PPP authentication type to use. After deciding which PPP authentication type to use, you must decide on a PPP client name and password to access the router.— Provide telephone number assigned to the remote office router serial interface to the corporate office network administrator and vice versa.• Network administrator from corporate office must order dial-up line from WAN service provider.
5	Frame Relay	<ul style="list-style-type: none">• Network administrators from corporate and remote offices:<ul style="list-style-type: none">— Set up IP and IPX address scheme.— Decide which IP routing protocol to use.• Network administrator from corporate office:<ul style="list-style-type: none">— Order two permanent virtual circuits (PVCs) from WAN service provider. Provider should assign two data link connection identifiers (DLCIs) for each PVC.— Ask WAN service provider to provide Local Management Interface (LMI) type.

¹ For a comparison of IP Routing Information Protocol (RIP) and IP Enhanced Interior Gateway Routing Protocol (EIGRP), refer to the “Selecting IP Routing Protocols” section in Appendix C, “Concepts.”

² For a comparison of Challenge Handshake Authentication Protocol (CHAP) or Password Authentication Protocol (PAP), refer to the “Selecting PPP Authentication Protocol” section in Appendix C, “Concepts.”

Network 1: Leased Line, HDLC

Figure 3-1 shows a sample remote-office-to-corporate-office network with a synchronous leased line running HDLC. This sample network uses IP as the only routed protocol and RIP to learn the route to the corporate office network.

Figure 3-1 **Network 1**

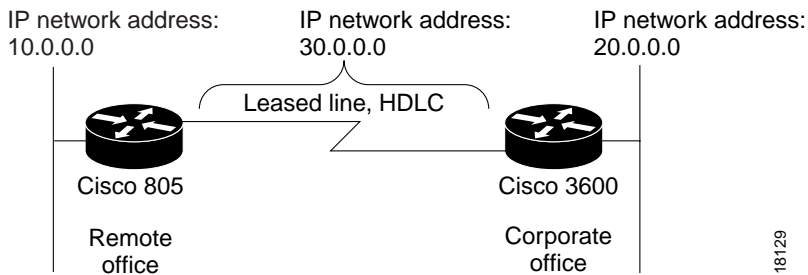

18129

Configuring the Cisco 805 Router

To configure the features for this sample network, perform the tasks described in the following sections on a PC. A sample configuration file that illustrates how to configure the network is presented after the tasks.

After your router boots, the following prompt displays. Enter **no**.

```
Would you like to enter the initial configuration dialog [yes]: no
```

For complete information on how to access global configuration mode, refer to the “Entering Global Configuration Mode” section in Chapter 2, “Cisco IOS Basic Skills.” For more information on the commands used in the following tables, refer to the Cisco IOS Release 12.0 documentation set.

Network 1: Leased Line, HDLC

Global Parameters

Use the following table to configure the router for global parameters.

Step	Task	Router Prompt	Command
1	Enter configuration mode.	Router#	configure terminal
2	Specify name for router.	Router (config)#	hostname name
3	Specify encrypted password to prevent unauthorized access to router.	Router (config)#	enable secret <password>
4	Configure router to recognize zero subnet range as valid range of addresses.	Router (config)#	ip subnet-zero
5	Disable router from translating unfamiliar words (typos) entered during a console session into IP addresses.	Router (config)#	no ip domain-lookup

Ethernet Interface

Use the following table to configure the Ethernet interface.

Step	Task	Router Prompt	Command
1	Enter configuration mode for Ethernet interface.	Router (config)#	interface ethernet 0
2	Set IP address and subnet mask.	Router (config-if)#	ip address ip-address mask
3	Enable interface and configuration changes just made to interface.	Router (config-if)#	no shutdown
4	Exit configuration mode for Ethernet interface.	Router (config-if)#	exit

Serial Interface

Use the following table to configure the serial interface.

Step	Task	Router Prompt	Command
1	Enter configuration mode for serial interface.	Router (config)#	interface serial 0
2	Set IP address and subnet mask.	Router (config-if)#	ip address <i>ip-address mask</i>
3	Enable interface and configuration changes just made to interface.	Router (config-if)#	no shutdown
4	Exit configuration mode for serial interface.	Router (config-if)#	exit

Dynamic Routing

This section describes how to configure RIP. For information on how to configure IP EIGRP, refer to the “Configuring IP EIGRP” section in Chapter 5, “Advanced Features.”

Use the following table to configure RIP.

Step	Task	Router Prompt	Command
1	Enter router configuration mode, and enable RIP.	Router (config)#	router rip
2	Specify use of RIP Version 2.	Router (config-router)#	version 2
3	Specify this command for each directly connected network.	Router (config-router)#	network <i>network-number</i>
4	Disable automatic summarization of subnet routes into network-level routes.	Router (config-router)#	no auto-summary
5	Exit router configuration mode.	Router (config-router)#	exit

Command-Line Access to the Router

Use the following table to configure parameters to control access to the router.

Step	Task	Router Prompt	Command
1	Enter line configuration mode, and specify the console terminal line.	Router (config)#	line console 0
2	Specify a unique password on the line.	Router (config-line)#	password <password>
3	Enable password checking at terminal session login.	Router (config-line)#	login
4	Set interval that EXEC command interpreter waits until user input is detected.	Router (config-line)#	exec-timeout 10 0
5	Specify a virtual terminal for remote console access.	Router (config-line)#	line vty 0 4
6	Specify a unique password on the line.	Router (config-line)#	password <password>
7	Enable password checking at virtual terminal session login.	Router (config-line)#	login
8	Exit line configuration mode, and return to privileged EXEC mode.	Router (config-line)#	end

Configuring the Corporate Router

This section assumes that the router connected to the Cisco 805 router is a Cisco router, such as a 3600 router. To configure the corporate router, use the same tasks as described in the “Configuring the Cisco 805 Router” section on page 3-5.

Sample Configuration

The following is a sample configuration based on performing the tasks in “Configuring the Cisco 805 Router” section on page 3-5. You do not need to input the commands marked “default.” These commands appear automatically in the configuration file generated when you use the **show running** command.

```
Current configuration:
!
version 12.0
no service pad (default)
service timestamps debug uptime (default)
service timestamps log uptime (default)
no service password-encryption (default)
hostname Cisco805
enable secret 5 $1$RnI.$K4mh5q4MFetaqKzBbQ7gv0
ip subnet-zero
no ip domain-lookup
!
interface Ethernet0
ip address 10.1.1.1 255.255.255.0
no ip directed-broadcast (default)
!
interface Serial0
ip address 30.1.1.1 255.255.255.0
no ip directed-broadcast (default)
no ip mroute-cache (default)
!
router rip
version 2
network 10.0.0.0
network 30.0.0.0
no auto-summary
!
no ip http server (default)
ip classless (default)
!
line con 0
exec-timeout 10 0
password 4youreyesonly
login
transport input none (default)
stopbits 1 (default)
line vty 0 4
password secret
login
!
end
```

Network 2: Leased Line, PPP

Figure 3-2 shows a sample remote-office-to-corporate-office network with a synchronous leased line running PPP. This sample network uses IP and IPX as the routed protocols and IP RIP and IPX RIP to learn the route to the corporate office network.

Figure 3-2 Network 2

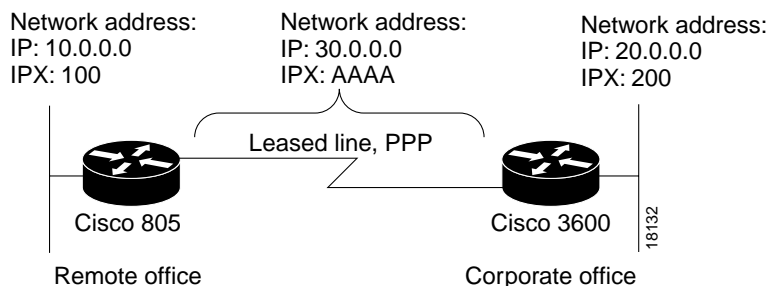

Configuring the Cisco 805 Router

To configure the features for this sample network, perform the tasks described in the following sections on a PC. A sample configuration file that illustrates how to configure the network is presented after the tasks.

After your router boots, the following prompt displays. Enter **no**.

```
Would you like to enter the initial configuration dialog [yes]: no
```

For complete information on how to access global configuration mode, refer to the “Entering Global Configuration Mode” section in Chapter 2, “Cisco IOS Basic Skills.” For more information on the commands used in the following tables, refer to the Cisco IOS Release 12.0 documentation set.

Global Parameters

Use the following table to configure the router for global parameters.

Step	Task	Router Prompt	Command
1	Enter configuration mode.	Router#	configure terminal
2	Specify name for router.	Router (config)#	hostname <i>name</i>
3	Specify encrypted password to prevent unauthorized access to router.	Router (config)#	enable secret <password>
4	Configure router to recognize zero subnet range as valid range of addresses.	Router (config)#	ip subnet-zero
5	Disable router from translating unfamiliar words (typos) entered during a console session into IP addresses.	Router (config)#	no ip domain-lookup
6	Enable IPX routing.	Router (config)#	ipx routing

Ethernet Interface

Use the following table to configure the Ethernet interface.

Step	Task	Router Prompt	Command
1	Enter configuration mode for Ethernet interface.	Router (config)#	interface ethernet 0
2	Set IP address and subnet mask.	Router (config-if)#	ip address <i>ip-address mask</i>
3	Enable IPX routing, assign IPX network number, and configure encapsulation (framing) type.	Router (config-if)#	ipx network <i>network</i> encapsulation {arpa novell-ether sap snap}
4	Enable interface and configuration changes just made to interface.	Router (config-if)#	no shutdown
5	Exit configuration mode for Ethernet interface.	Router (config-if)#	exit

Serial Interface

Use the following table to configure the serial interface.

Step	Task	Router Prompt	Command
1	Enter configuration mode for serial interface.	Router (config)#	interface serial 0
2	Set IP address and subnet mask.	Router (config-if)#	ip address <i>ip-address mask</i>
3	Enable IPX routing, and configure IPX network number.	Router (config-if)#	ipx network <i>network</i>
4	Specify PPP as encapsulation (framing) type.	Router (config-if)#	encapsulation ppp
5	Enable interface and configuration changes just made to interface.	Router (config-if)#	no shutdown
6	Exit configuration mode for serial interface.	Router (config-if)#	exit

Note Although CHAP and PAP are not commonly used with a leased line, you can set them up on your serial interface to authenticate your connection to the corporate office router. For more information, refer to the “Selecting PPP Authentication Protocol” section in Appendix C, “Concepts.”

Dynamic Routing

This section describes how to configure IP RIP. (IPX RIP is enabled by default.) For information on how to configure IP EIGRP, refer to the “Configuring IP EIGRP” section in Chapter 5, “Advanced Features.”

Use the following table to configure IP RIP.

Step	Task	Router Prompt	Command
1	Enter router configuration mode, and enable RIP.	Router (config)#	router rip
2	Specify use of RIP Version 2.	Router (config-router)#	version 2

Step	Task	Router Prompt	Command
3	Specify this command for each directly connected network.	Router (config-router)#	network <i>network-number</i>
4	Disable automatic summarization of subnet routes into network-level routes.	Router (config-router)#	no auto-summary
5	Exit router configuration mode.	Router (config-router)#	exit

Command-Line Access to the Router

Use the following table to configure parameters to control access to the router.

Step	Task	Router Prompt	Command
1	Enter line configuration mode, and specify the console terminal line.	Router (config)#	line console 0
2	Specify a unique password on the line.	Router (config-line)#	password <password>
3	Enable password checking at terminal session login.	Router (config-line)#	login
4	Set interval that EXEC command interpreter waits until user input is detected.	Router (config-line)#	exec-timeout 10 0
5	Specify a virtual terminal for remote console access.	Router (config-line)#	line vty 0 4
6	Specify a unique password on the line.	Router (config-line)#	password <password>
7	Enable password checking at virtual terminal session login.	Router (config-line)#	login
8	Exit line configuration mode, and return to privileged EXEC mode.	Router (config-line)#	end

Configuring the Corporate Router

This section assumes that the router connected to the Cisco 805 router is a Cisco router, such as a 3600 router. To configure the corporate router, use the same tasks as described in the “Configuring the Cisco 805 Router” section on page 3-10.

Sample Configuration

The following is a sample configuration based on performing the tasks in “Configuring the Cisco 805 Router” section on page 3-10. You do not need to input the commands marked “default.” These commands appear automatically in the configuration file generated when you use the **show running** command.

```
Current configuration:
!
version 12.0
no service pad (default)
service timestamps debug uptime (default)
service timestamps log uptime (default)
no service password-encryption (default)
hostname Cisco805
enable secret 5 $1$RnI.$K4mh5q4MFetaqKzBbQ7gv0
ip subnet-zero
no ip domain-lookup
ipx routing 0010.7b7e.5499
!In the preceding command, the router MAC address is automatically used
!as the router IPX address.
!
interface Ethernet0
ip address 10.1.1.1 255.255.255.0
no ip directed-broadcast (default)
ipx network 100 encapsulation novell-ether
!
interface Serial0
ip address 30.1.1.1 255.255.255.0
no ip directed-broadcast (default)
encapsulation ppp
no ip mroute-cache (default)
ipx network AAAA
!
router rip
version 2
network 10.0.0.0
```

```

network 30.0.0.0
no auto-summary
!
no ip http server (default)
ip classless (default)
!
line con 0
exec-timeout 10 0
password 4youreyesonly
login
transport input none (default)
stopbits 1 (default)
line vty 0 4
password secret
login
!
end

```

Network 3: X.25

Figure 3-3 shows a sample remote office network connected to a corporate office network with X.25. This sample network uses IP and IPX as the routed protocols and IP RIP and IPX RIP to learn the route to the corporate office.

Figure 3-3 Network 3

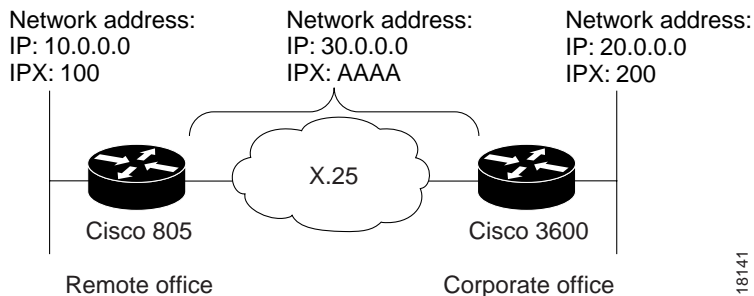

Configuring the Cisco 805 Router

To configure the features for this sample network, perform the tasks described in the following sections on a PC. A sample configuration file that illustrates how to configure the network is presented after the tasks.

After your router boots, the following prompt displays. Enter **no**.

```
Would you like to enter the initial configuration dialog [yes]: no
```

For complete information on how to access global configuration mode, refer to the “Entering Global Configuration Mode” section in Chapter 2, “Cisco IOS Basic Skills.” For more information on the commands used in the following tables, refer to the Cisco IOS Release 12.0 documentation set.

Global Parameters

Use the following table to configure the router for global parameters.

Step	Task	Router Prompt	Command
1	Enter configuration mode.	Router#	configure terminal
2	Specify name for router.	Router (config)#	hostname <i>name</i>
3	Specify encrypted password to prevent unauthorized access to router.	Router (config)#	enable secret <password>
4	Configure router to recognize zero subnet range as valid range of addresses.	Router (config)#	ip subnet-zero
5	Disable router from translating unfamiliar words (typos) entered during a console session into IP addresses.	Router (config)#	no ip domain-lookup
6	Enable IPX routing.	Router (config)#	ipx routing

Ethernet Interface

Use the following table to configure the Ethernet interface.

Step	Task	Router Prompt	Command
1	Enter configuration mode for Ethernet interface.	Router (config)#	interface ethernet 0
2	Set IP address and subnet mask.	Router (config-if)#	ip address <i>ip-address mask</i>
3	Enable IPX routing, assign IPX network number, and configure encapsulation (framing) type.	Router (config-if)#	ipx network <i>network</i> encapsulation { <i>arpa</i> <i>novell-ether</i> <i>sap</i> <i>snap</i> }
4	Enable interface and configuration changes just made to interface.	Router (config-if)#	no shutdown
5	Exit configuration mode for Ethernet interface.	Router (config-if)#	exit

Serial Interface

Use the following table to configure the serial interface. This table provides basic X.25 commands to configure your serial interface to route IP and IPX packets over X.25. For information on other less commonly performed X.25-related tasks, refer to the *Wide-Area Networking Configuration Guide*.

Step	Task	Router Prompt	Command
1	Enter configuration mode for serial interface.	Router (config)#	interface serial 0
2	Set IP address and subnet mask.	Router (config-if)#	ip address <i>ip-address mask</i>
3	Enable IPX routing, and configure IPX network number.	Router (config-if)#	ipx network <i>network</i>
4	Specify X.25 as encapsulation (framing) type.	Router (config-if)#	encapsulation x25
5	Set X.25 address (provided by your WAN service provider).	Router (config-if)#	x25 address <i>address</i>

Network 3: X.25

Step	Task	Router Prompt	Command
6	Enter this command once to set up LAN protocols-to-remote-host mapping for IP and X.25 and another time to set up mapping for IPX and X.25.	Router (config-if)#	x25 map protocol protocol-address x.121-address broadcast
7	Set network incoming window size (provided by your WAN service provider).	Router (config-if)#	x25 win packets
8	Set network outgoing window size (provided by your WAN service provider).	Router (config-if)#	x25 wout packets
9	Set network maximum input packet size (provided by your WAN service provider).	Router (config-if)#	x25 ips bytes
10	Set network maximum output packet size (provided by your WAN service provider).	Router (config-if)#	x25 ops bytes
11	Enable interface and configuration changes just made to interface.	Router (config-if)#	no shutdown
12	Exit configuration mode for serial interface.	Router (config-if)#	exit

Dynamic Routing

This section describes how to configure IP RIP. (IPX RIP is enabled by default.) For information on how to configure IP EIGRP, refer to the “Configuring IP EIGRP” section in Chapter 5, “Advanced Features.”

Use the following table to configure IP RIP.

Step	Task	Router Prompt	Command
1	Enter router configuration mode, and enable RIP.	Router (config)#	router rip
2	Specify use of RIP Version 2.	Router (config-router)#	version 2
3	Specify this command for each directly connected network.	Router (config-router)#	network network-number

Step	Task	Router Prompt	Command
4	Disable automatic summarization of subnet routes into network-level routes.	Router (config-router)#	no auto-summary
5	Exit router configuration mode.	Router (config-router)#	exit

Command-Line Access to the Router

Use the following table to configure parameters to control access to the router.

Step	Task	Router Prompt	Command
1	Enter line configuration mode, and specify the console terminal line.	Router (config)#	line console 0
2	Specify a unique password on the line.	Router (config-line)#	password <i><password></i>
3	Enable password checking at terminal session login.	Router (config-line)#	login
4	Set interval that EXEC command interpreter waits until user input is detected.	Router (config-line)#	exec-timeout 10 0
5	Specify a virtual terminal for remote console access.	Router (config-line)#	line vty 0 4
6	Specify a unique password on the line.	Router (config-line)#	password <i><password></i>
7	Enable password checking at virtual terminal session login.	Router (config-line)#	login
8	Exit line configuration mode, and return to privileged EXEC mode.	Router (config-line)#	end

Configuring the Corporate Router

This section assumes that the router connected to the Cisco 805 router is a Cisco router, such as a 3600 router. To configure the corporate router, use the same tasks as described in the “Configuring the Cisco 805 Router” section on page 3-16.

Sample Configuration

The following is a sample configuration based on performing the tasks in “Configuring the Cisco 805 Router” section on page 3-16. You do not need to input the commands marked “default.” These commands appear automatically in the configuration file generated when you use the **show running** command.

While reviewing the following configuration, also refer to Figure 3-4, which illustrates the configuration specifics for mapping addresses between IP, IPX, and X.25.

```
Current configuration:
!
version 12.0
no service pad (default)
service timestamps debug uptime (default)
service timestamps log uptime (default)
no service password-encryption (default)
hostname Cisco805
enable secret 5 $1$RnI.$K4mh5q4MFetaqKzBbQ7gv0
ip subnet-zero
no ip domain-lookup
ipx routing 0010.7b7e.5499
!In the preceding command, the router MAC address is automatically used
!as the router IPX address.
!
interface Ethernet0
ip address 10.1.1.1 255.255.255.0
no ip directed-broadcast (default)
ipx network 100 encapsulation novell-ether
!
interface Serial0
ip address 30.1.1.1 255.255.255.0
ipx network AAAA
no ip directed-broadcast (default)
encapsulation x25
no ip mroute-cache (default)
x25 address 31370054065
x25 win 7
x25 wout 7
x25 ips 512
x25 ops 512
x25 map ip 30.1.1.2 31370054066 broadcast
x25 map ipx AAAA.0010.7b7e.5598 31370054066 broadcast
```

```

!In the two preceding commands, you map the IP and IPX addresses
!assigned to the corporate office router serial interface to the X.25
!address assigned to the corporate office router serial interface. See
!Figure 3-4.
!
router rip
version 2
network 10.0.0.0
network 30.0.0.0
no auto-summary
!
no ip http server (default)
ip classless (default)
!
line con 0
exec-timeout 10 0
password 4youreyesonly
login
transport input none (default)
stopbits 1 (default)
line vty 0 4
password secret
login
!
end

```

Figure 3-4 Sample X.25 Network

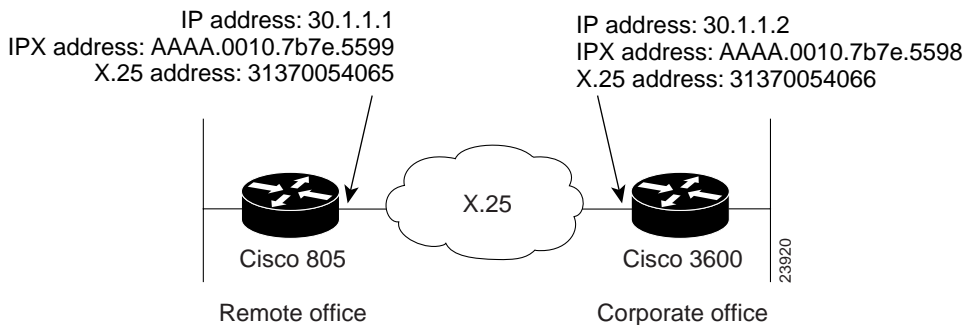

Network 4: Dial-up Line, PPP

Figure 3-5 shows a sample remote office network connected to a corporate office network with an asynchronous dial-up line running PPP. This sample network uses IP and IPX as the routed protocols. Instead of using dynamic routing protocols such as IP and IPX RIP to learn the route to the corporate network, this network uses *static IP and IPX routes*, which are user-defined routes to the corporate network.

This sample network uses the dial-on-demand routing (DDR) implementation of dialer profiles. For more information, refer to the “Dialer Profiles” section in Appendix C, “Concepts.”

Figure 3-5 Network 4

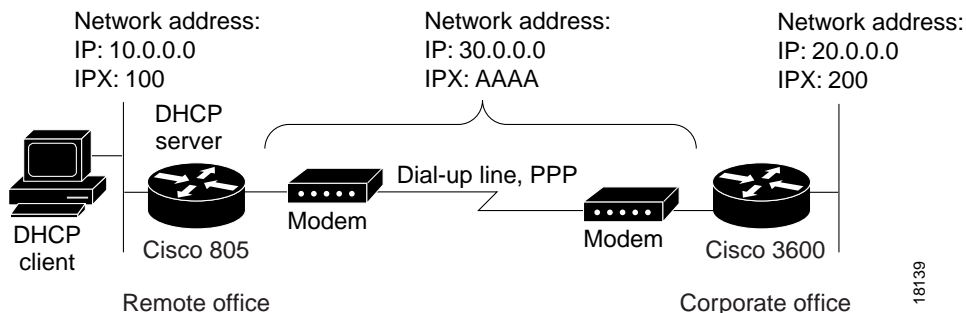

18139

You can also configure the Cisco 805 router as a DHCP server. (The DHCP server feature is part of Easy IP [Phase 2]). A DHCP server allocates IP addresses from a central pool to DHCP clients on the remote office network.

Configuring the Cisco 805 Router

To configure the features for this sample network, perform the tasks described in the following sections on a PC. A sample configuration file that illustrates how to configure the network is presented after the tasks.

After your router boots, the following prompt displays. Enter **no**.

Would you like to enter the initial configuration dialog [yes]: **no**

For complete information on how to access global configuration mode, refer to the “Entering Global Configuration Mode” section in Chapter 2, “Cisco IOS Basic Skills.” For more information on the commands used in the following tables, refer to the Cisco IOS Release 12.0 documentation set.

Global Parameters

Use the following table to configure the router for global parameters.

Step	Task	Router Prompt	Command
1	Enter configuration mode.	Router#	configure terminal
2	Specify name for router.	Router (config)#	hostname name
3	Specify encrypted password to prevent unauthorized access to router.	Router (config)#	enable secret <password>
4	Specify username and password used during caller identification and PAP and CHAP authentication. Username and password entered with this command must match hostname and password on corporate router.	Router (config)#	username name password <secret>
5	Configure router to recognize zero subnet range as valid range of addresses.	Router (config)#	ip subnet-zero
6	Disable router from translating unfamiliar words (typos) entered during a console session into IP addresses.	Router (config)#	no ip domain-lookup
7	Enable IPX routing.	Router (config)#	ipx routing
8	Specify static SAP entries. For more information on SAP types, refer to your Novell NetWare documentation.	Router (config)#	ipx sap service-type name network.node socket hop-count

Network 4: Dial-up Line, PPP

Ethernet Interface

Use the following table to configure the Ethernet interface.

Step	Task	Router Prompt	Command
1	Enter configuration mode for Ethernet interface.	Router (config)#	interface ethernet 0
2	Set IP address and subnet mask.	Router (config-if)#	ip address <i>ip-address mask</i>
3	Enable IPX routing, assign IPX network number, and configure encapsulation (framing) type.	Router (config-if)#	ipx network <i>network</i> encapsulation {arpa novell-ether sap snap}
4	Enable interface and configuration changes just made to interface.	Router (config-if)#	no shutdown
5	Exit configuration mode for Ethernet interface.	Router (config-if)#	exit

Serial Interface

Use the following table to configure the serial interface.

Step	Task	Router Prompt	Command
1	Enter configuration mode for serial interface.	Router (config)#	interface serial 0
2	Disable IP processing.	Router (config-if)#	no ip address
3	Specify PPP as encapsulation (framing) type.	Router (config-if)#	encapsulation ppp
4	Enable CHAP and/or PAP.	Router (config-if)#	ppp authentication chap pap or ppp authentication chap or ppp authentication pap
5	Specify mode of serial interface as asynchronous.	Router (config-if)#	physical-layer async
6	Configure asynchronous line for data traffic.	Router (config-if)#	async mode dedicated

Step	Task	Router Prompt	Command
7	Specify that you are using DDR.	Router (config-if)#	dialer in-band
8	Set up dialer pool, and assign serial interface to the dialer pool.	Router (config-if)#	dialer pool-member <i>number</i>
9	Enable interface and configuration changes just made to interface.	Router (config-if)#	no shutdown
10	Exit serial interface configuration mode.	Router (config-line)#	exit

Dialer Profile

To configure the dialer profile, you must set up a dialer interface and dialer pool. (The dialer pool is set up with the serial interface.) For conceptual information, refer to the “Dialer Profiles” section in Appendix C, “Concepts.”

Use the following table to configure the dialer interface.

Step	Task	Router Prompt	Command
1	Enter configuration mode for and define dialer rotary group.	Router (config)#	interface dialer 1
2	Set IP address and subnet mask.	Router (config-if)#	ip address <i>ip-address mask</i>
3	Specify PPP as encapsulation (framing) type.	Router (config-if)#	encapsulation ppp
4	Enable CHAP and/or PAP.	Router (config-if)#	ppp authentication chap pap or ppp authentication chap or ppp authentication pap
5	Specify corporate office router authentication name.	Router (config-if)#	dialer remote-name <i>name</i>
6	Specify amount of idle time before calls are disconnected.	Router (config-if)#	dialer idle-timeout <i>seconds</i>

Network 4: Dial-up Line, PPP

Step	Task	Router Prompt	Command
7	Specify telephone number of corporate office router.	Router (config-if)#	dialer string <i>string</i>
8	Specify dialer pool to use for calls to corporate office. (Dialer pool was set up in “Serial Interface” section on page 3-24.)	Router (config-if)#	dialer pool <i>number</i>
9	Assign dialer interface to a dialer group.	Router (config-if)#	dialer-group <i>number</i>
10	Disable CDP.	Router (config-if)#	no cdp enable
11	Enable IPX routing, and configure IPX network number.	Router (config-if)#	ipx network <i>network</i>
12	Disable IPX fast switching.	Router (config-if)#	no ipx route-cache
13	Configure router to respond to watchdog packets of a server on behalf of a remote client.	Router (config-if)#	ipx watchdog-spoof
14	Configure router to respond to client or server SPX keepalive packets on behalf of a remote system.	Router (config-if)#	ipx spx-spoof
15	Exit configuration mode for dialer interface.	Router (config-if)#	exit
16	Set up IP static route to corporate router.	Router (config)#	ip route <i>destination-network destination-subnet-mask next-hop</i>
17	Create script that causes connected modem to place call to other corporate route.	Router (config)#	chat-script <i>script-name expect-send</i>
18	Set up IPX static route to corporate router.	Router (config)#	ipx route <i>network next-hop</i>
19	Set up dialer list that determines which protocols trigger a call. (Enter one command for each protocol that you want to permit.)	Router (config)#	dialer-list <i>dialer-group protocol protocol-name</i> permit

For information on controlling the types of traffic that can activate your dial-up line and increase your monthly dial-up line cost, refer to the “Controlling Dial-up Line Activation” section in Chapter 5, “Advanced Features.”

Asynchronous Line

Use the following table to configure the asynchronous line.

Step	Task	Router Prompt	Command
1	Enter configuration mode for asynchronous line (line 1).	Router (config)#	line 1
2	Set hardware flow control.	Router (config-line)#	flowcontrol hardware
3	Specify that all protocols can connect to line 1.	Router (config-line)#	transport input all
4	Configure line 1 for both incoming and outgoing calls.	Router (config-line)#	modem inout
5	Set baud rate.	Router (config-line)#	speed 115200
6	Set stop bits.	Router (config-line)#	stopbits 1
7	Exit asynchronous line configuration mode.	Router (config-line)#	exit

DHCP Server

For information on configuring the Cisco 805 router as a DHCP server, refer to the “DHCP Server” section in Chapter 5, “Advanced Features.”

Command-Line Access to the Router

Use the following table to configure parameters to control access to the router.

Step	Task	Router Prompt	Command
1	Enter line configuration mode, and specify the console terminal line.	Router (config)#	line console 0
2	Specify a unique password on the line.	Router (config-line)#	password <password>
3	Enable password checking at terminal session login.	Router (config-line)#	login
4	Set interval that EXEC command interpreter waits until user input is detected.	Router (config-line)#	exec-timeout 10 0

Network 4: Dial-up Line, PPP

Step	Task	Router Prompt	Command
5	Specify a virtual terminal for remote console access.	Router (config-line)#	line vty 0 4
6	Specify a unique password on the line.	Router (config-line)#	password <password>
7	Enable password checking at virtual terminal session login.	Router (config-line)#	login
8	Exit line configuration mode, and return to privileged EXEC mode.	Router (config-line)#	end

Configuring the Corporate Router

This section assumes that the router connected to the Cisco 805 router is a Cisco router, such as a Cisco 3600 router. To configure the corporate router, use the same tasks as described in the “Configuring the Cisco 805 Router” section on page 3-22 except do not configure the corporate router as a DHCP server.

Sample Configuration

The following is a sample configuration based on performing the tasks in “Configuring the Cisco 805 Router” section on page 3-22. You do not need to input the commands marked “default.” These commands appear automatically in the configuration file generated when you use the **show running** command.

Current configuration:

```
!  
version 12.0  
no service pad (default)  
service timestamps debug uptime (default)  
service timestamps log uptime (default)  
no service password-encryption (default)  
hostname Cisco805  
enable secret 5 $1$RnI.$K4mh5q4MFetaqKzBbQ7gv0  
username Cisco3600 password abracadabra  
ip subnet-zero  
!  
ip dhcp pool dhcppool_1  
network 10.1.1.1 255.255.255.0  
default-router 10.1.1.1  
!  
no ip domain-lookup  
ipx routing 0010.7b7e.5499  
!In the preceding command, the router MAC address is automatically used  
!as the router IPX address.  
chat-script dial "" AT OK "\patdt\T" TIMEOUT 60 CONNECT \C  
!This generic chat script is known to work. For information on  
!customizing your chat script, refer to the Dial Solutions Configuration  
!Guide.  
  
interface Ethernet0  
ip address 10.1.1.1 255.255.255.0  
no ip directed-broadcast (default)  
ipx network 100 encapsulation novell-ether  
!  
interface Serial0  
physical-layer async  
no ip address  
no ip directed-broadcast (default)  
encapsulation ppp  
dialer in-band  
dialer pool-member 1  
async default routing  
async mode dedicated  
ppp authentication chap pap  
!  
interface Dialer1  
ip address 30.1.1.1 255.255.255.0  
no ip directed-broadcast (default)  
encapsulation ppp
```

Network 4: Dial-up Line, PPP

```
dialer remote-name Cisco3600
dialer idle-timeout 500
dialer string 5551111
dialer pool 1
dialer-group 1
ipx network AAAA
no ipx route-cache
ipx watchdog-spoof
ipx spx-spoof
no cdp enable
ppp authentication chap pap
!
no ip http server (default)
ip classless (default)
!
ip route 20.1.1.0 255.255.255.0 30.1.1.2
ipx route 200 AAAA.0010.7b7e.5477
ipx sap 4 corporate-server 200.0020.0c00.75ec 452 1
dialer-list 1 protocol ip permit
dialer-list 1 protocol ipx permit
!
line con 0
exec-timeout 10 0
password 4youreyesonly
login
transport input none (default)
stopbits 1 (default)
line 1
modem InOut
transport input all
speed 115200
flowcontrol hardware
line vty 0 4
password secret
login
!
end
```

Network 5: Frame Relay

Figure 3-6 shows a sample remote-office-to-corporate-office network that uses Frame Relay. This sample network uses IP and IPX as the routed protocols and IP and IPX RIP to learn the routes to the corporate network.

Figure 3-6 Network 5

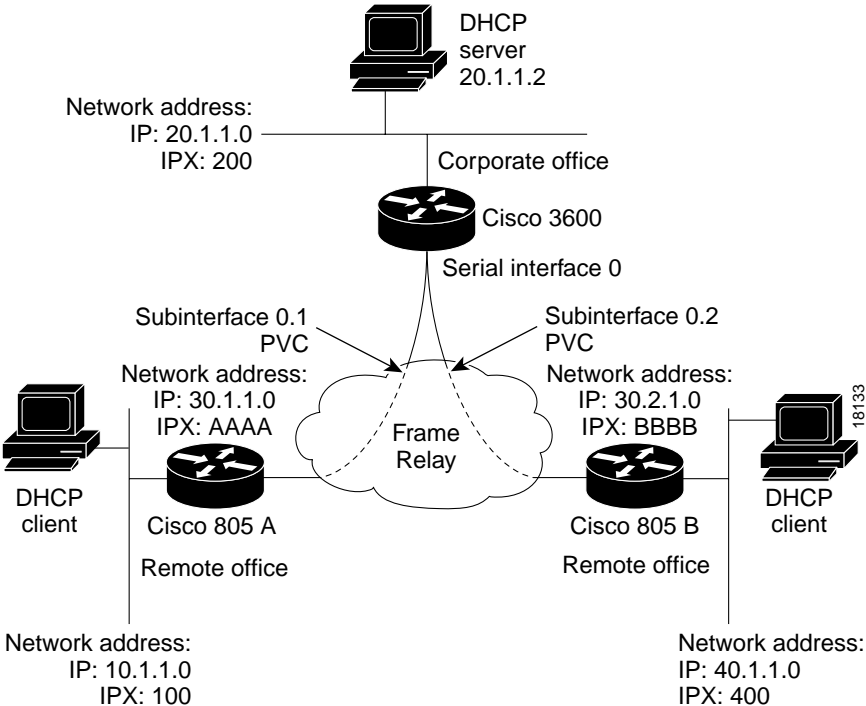

This sample network uses a *partially meshed* Frame Relay topology, which means that each router is not directly connected to every other router. In this network, the remote office routers are not directly connected. However, serial interface 0 on the corporate office router is divided into virtual subinterfaces so that the remote office routers can communicate

through the corporate office router. Each subinterface has a *permanent virtual circuit* (PVC) associated with it. For more information on partially meshed topologies, subinterfaces, and PVCs, refer to the Cisco IOS Release 12.0 documentation set.

The corporate network also has a PC or workstation that runs DHCP (a *DHCP server*). The DHCP server provides IP addresses to LAN devices on the remote networks (*DHCP clients*). You can set up the DHCP relay feature on the Cisco 805 router so that it relays DHCP client requests for IP addresses from the LAN interface, over the serial interface, and to the DHCP server. The DHCP relay feature is part of Easy IP (Phase 2).

Configuring the Cisco 805 Routers

To configure the features for this sample network, perform the tasks described in the following sections on a PC. A sample configuration file that illustrates how to configure the network is presented after the tasks.

After your router boots, the following prompt displays. Enter **no**.

```
Would you like to enter the initial configuration dialog [yes]: no
```

For complete information on how to access global configuration mode, refer to the “Entering Global Configuration Mode” section in Chapter 2, “Cisco IOS Basic Skills.” For more information on the commands used in the following tables, refer to the Cisco IOS Release 12.0 documentation set.

Global Parameters

Use the following table to configure the routers for global parameters.

Step	Task	Router Prompt	Command
1	Enter configuration mode.	Router#	configure terminal
2	Specify name for router.	Router (config)#	hostname name
3	Specify encrypted password to prevent unauthorized access to router.	Router (config)#	enable secret <password>
4	Configure router to recognize zero subnet range as valid range of addresses.	Router (config)#	ip subnet-zero

Step	Task	Router Prompt	Command
5	Disable router from translating unfamiliar words (typos) entered during a console session into IP addresses.	Router (config)#	no ip domain-lookup
6	Enable IPX routing.	Router (config)#	ipx routing

Ethernet Interface

Use the following table to configure the Ethernet interface.

Step	Task	Router Prompt	Command
1	Enter configuration mode for Ethernet interface.	Router (config)#	interface ethernet 0
2	Set IP address and subnet mask.	Router (config-if)#	ip address <i>ip-address mask</i>
3	Enable IPX routing, assign IPX network number, and configure encapsulation (framing) type.	Router (config-if)#	ipx network <i>network</i> encapsulation {arpa novell-ether sap snap}
4	Enable interface and configuration changes just made to interface.	Router (config-if)#	no shutdown
5	Exit configuration mode for Ethernet interface.	Router (config-if)#	exit

Serial Interface

Use the following table to configure the serial interface.

Step	Task	Router Prompt	Command
1	Enter configuration mode for serial interface.	Router (config)#	interface serial 0
2	Set IP address and subnet mask.	Router (config-if)#	ip address <i>ip-address mask</i>
3	Enable IPX network, and configure IPX network number.	Router (config-if)#	ipx network <i>network</i>

Network 5: Frame Relay

Step	Task	Router Prompt	Command
4	Specify Frame Relay as encapsulation (framing) type.	Router (config-if)#	encapsulation frame relay
5	Set LMI type to the type provided by Frame Relay service provider. (Default is cisco .)	Router (config-if)#	frame-relay lmi-type {ansi cisco q933a}
6	Enable interface and configuration changes just made to interface.	Router (config-if)#	no shutdown
7	Exit configuration mode for serial interface.	Router (config-if)#	exit

Dynamic Routing

This section describes how to configure IP RIP. (IPX RIP is enabled by default.) For information on how to configure IP EIGRP, refer to the “Configuring IP EIGRP” section in Chapter 5, “Advanced Features.”

Use the following table to configure IP RIP.

Step	Task	Router Prompt	Command
1	Enter router configuration mode, and enable RIP.	Router (config)#	router rip
2	Specify use of RIP Version 2.	Router (config-router)#	version 2
3	Specify this command for each directly connected network.	Router (config-router)#	network network-number
4	Disable automatic summarization of subnet routes into network-level routes.	Router (config-router)#	no auto-summary
5	Exit router configuration mode.	Router (config-router)#	exit

DHCP Relay

For information on configuring DHCP relay, refer to the “DHCP Relay” section in Chapter 5, “Advanced Features.”

Command-Line Access to the Routers

Use the following table to configure parameters to control access to the router.

Step	Task	Router Prompt	Command
1	Enter line configuration mode, and specify the console terminal line.	Router (config)#	line console 0
2	Specify a unique password on the line.	Router (config-line)#	password <password>
3	Enable password checking at terminal session login.	Router (config-line)#	login
4	Set interval that EXEC command interpreter waits until user input is detected.	Router (config-line)#	exec-timeout 10 0
5	Specify a virtual terminal for remote console access.	Router (config-line)#	line vty 0 4
6	Specify a unique password on the line.	Router (config-line)#	password <password>
7	Enable password checking at virtual terminal session login.	Router (config-line)#	login
8	Exit line configuration mode, and return to privileged EXEC mode.	Router (config-line)#	end

Configuring the Corporate Router

This section assumes that the corporate router is a Cisco router, such as a 3600 router. To configure the corporate router, use the same tasks as described in the “Configuring the Cisco 805 Routers” section on page 3-32. There are some differences in how you configure the corporate router:

- Instead of setting an IP address and subnet address for the serial interface, specify the **no ip address** command in serial interface configuration mode. Do not specify an IPX address. (Instead, you set IP and IPX addresses for the serial subinterfaces.)
- Configure two serial subinterfaces after you finish configuring the serial interface.
- Do not configure the DHCP relay feature.

Network 5: Frame Relay

Use the following table to configure each subinterface. (The sample network uses two subinterfaces (0.1 and 0.2); therefore, you must perform the steps in the following table twice.)

Step	Task	Router Prompt	Command
1	Enter configuration mode for the serial subinterface, and specify interface as a point-to-point connection.	Router (config)#	interface serial <i>interface.subinterface</i> point-to-point
2	Set IP address and subnet mask.	Router (config-if)#	ip address <i>ip-address mask</i>
3	Enable IPX network, and configure IPX network number.	Router (config-if)#	ipx network <i>network</i>
4	Associate a DLCI with subinterface.	Router (config-if)#	frame-relay interface-dlci <i>dldci</i>
5	Exit configuration mode for serial interface.	Router (config-if)#	exit

Sample Cisco 805 Routers Configurations

The following are sample configurations for the Cisco 805 A and Cisco 805 B routers, respectively, which are shown in Figure 3-6. These configurations are based on performing the tasks in “Configuring the Cisco 805 Routers” section on page 3-32. You do not need to input the commands marked “default.” These commands appear automatically in the configuration file generated when you use the **show running** command.

```
Current configuration:
!
version 12.0
no service pad (default)
service timestamps debug uptime (default)
service timestamps log uptime (default)
no service password-encryption (default)
hostname Cisco805A
enable secret 5 $1$RnI.$K4mh5q4MFetaqKzBbQ7gv0
ip subnet-zero
no ip domain-lookup
ip dhcp-server 20.1.1.2
ipx routing 0010.7b7e.5499
```

```
!In the preceding command, the router MAC address is automatically used
!as the router IPX address.
!
interface Ethernet0
ip address 10.1.1.1 255.255.255.0
no ip directed-broadcast (default)
ipx network 100 novell-ether
!
interface Serial0
ip address 30.1.1.1 255.255.255.0
ip helper-address 20.1.1.2
no ip directed-broadcast (default)
encapsulation frame-relay
no ip mroute-cache (default)
ipx network AAAA
frame-relay lmi-type ansi
!
router rip
version 2
network 10.0.0.0
network 30.0.0.0
no auto-summary
!
no ip http server (default)
ip classless (default)
!
line con 0
exec-timeout 10 0
password 4youreyesonly
login
transport input none (default)
stopbits 1 (default)
line vty 0 4
password secret
login
!
end
```

Network 5: Frame Relay

```
Current configuration:
!
version 12.0
no service pad (default)
service timestamps debug uptime (default)
service timestamps log uptime (default)
no service password-encryption (default)
hostname Cisco805B
enable secret 6 %tu0jue]we940./7
ip subnet-zero
no ip domain-lookup
ip dhcp-server 20.1.1.2
ipx routing 0010.7b7e.5497
!In the preceding command, the router MAC address is automatically used
!as the router IPX address.
!
interface Ethernet0
ip address 40.1.1.1 255.255.255.0
no ip directed-broadcast (default)
ipx network 400
!
interface Serial0
ip address 30.2.1.1 255.255.255.0
ip helper-address 20.1.1.2
no ip directed-broadcast (default)
encapsulation frame-relay
no ip mroute-cache (default)
ipx network BBBB
frame-relay lmi-type ansi
!
router rip
version 2
network 30.0.0.0
network 40.0.0.0
no auto-summary
!
no ip http server (default)
ip classless (default)
!
line con 0
exec-timeout 10 0
password 4youreyesonly
login
transport input none (default)
stopbits 1 (default)
```

```
line vty 0 4
password secret
login
!
end
```

Sample Cisco 3600 Router Configuration

The following is a sample configuration for the Cisco 3600 router. This configuration is based on performing the tasks in “Configuring the Corporate Router” section on page 3-35. You do not need to input the commands marked “default.” These commands appear automatically in the configuration file generated when you use the **show running** command.

While reviewing the following configuration, also refer to Figure 3-7, which shows the configuration specifics for the Cisco 3600 router.

```
Current configuration:
!
version 12.0
no service pad (default)
service timestamps debug uptime (default)
service timestamps log uptime (default)
no service password-encryption (default)
hostname Cisco3600
enable secret 8 #7eu2;odg*#, .
ip subnet-zero
no ip domain-lookup
ipx routing 0010.7b7e.5498
!In the preceding command, the router MAC address is automatically used
!as the router IPX address.
!
interface Ethernet0
ip address 20.1.1.1 255.255.255.0
no ip directed-broadcast (default)
ipx network 200
!
interface Serial0
no ip address
no ip directed-broadcast (default)
encapsulation frame-relay
no ip mroute-cache (default)
frame-relay lmi-type ansi
```

Network 5: Frame Relay

```
!  
interface Serial0.1 point-to-point  
ip address 30.1.1.2 255.255.255.0  
no ip directed-broadcast (default)  
ipx network AAAA  
frame-relay interface-dlci 17  
!  
interface Serial0.2 point-to-point  
ip address 30.2.1.2 255.255.255.0  
no ip directed-broadcast (default)  
ipx network BBBB  
frame-relay interface-dlci 18  
!  
router rip  
version 2  
network 20.0.0.0  
network 30.0.0.0  
no auto-summary  
!  
no ip http server (default)  
ip classless (default)  
!  
line con 0  
exec-timeout 10 0  
password 4youreyesonly  
login  
transport input none (default)  
stopbits 1 (default)  
line vty 0 4  
password secret  
login  
!  
end
```

Figure 3-7 Sample Cisco 3600 Router Configuration

