

# Maintenance

---

This chapter contains maintenance and troubleshooting procedures:

- Accessing the Internal Components of the Router
- Replacing Network Processor Modules
- Replacing the Component Tray
- Use of the Slot Filler Panel
- Problem Solving
- Environmental Reporting Features
- LEDs

## Accessing the Internal Components of the Router

You must open the chassis to gain access to the router's internal components—the network processor modules, boot ROMs, and jumpers.

Refer to the section “Required Tools and Equipment” in the chapter “Preparing to Install the Router” for the tools needed to complete the procedures in this chapter.



**Warning** Before opening the chassis, disconnect the telephone-network cables to avoid contact with telephone-network voltages.



**Warning** Do not work on the system or connect or disconnect cables during periods of lightning activity.



**Warning** Do not touch the power supply when the power cord is connected. For systems with a power switch, line voltages are present within the power supply even when the power switch is off and the power cord is connected. For systems without a power switch, line voltages are present within the power supply when the power cord is connected.



**Warning** Before working on a chassis or working near power supplies, unplug the power cord on AC units; disconnect the power at the circuit breaker on DC units.

### Removing the Component Tray

Some Cisco 4000 series routers have a safety latch tab on the chassis that affects removing the component tray. (See Figure 6-1 and Figure 6-2.)

If you have a chassis with a safety latch tab, follow the procedure in the next section “Removing the Component Tray from a Chassis with a Safety Latch.”

If you have a chassis without a safety latch tab, follow the procedure in the section “Removing the Component Tray from a Chassis without a Safety Latch.”

### Removing the Component Tray from a Chassis with a Safety Latch

Take the following steps to remove the component tray from a chassis with a safety latch:

- Step 1** Turn OFF the system power.
- Step 2** Put on your ESD-preventive wrist strap.
- Step 3** Remove all network and power cables.
- Step 4** Loosen the nonremovable chassis release screw on the rear panel of the chassis. (See Figure 6-1.)
- Step 5** Pull on the handle located on the upper right corner of the chassis to slide the component tray out of the chassis shell until the safety latch catches. (See Figure 6-1.)



**Warning** Before releasing the safety latch, support the component tray from underneath, either on your work surface or with your hands, to prevent personal injury. (See Figure 6-1.)

**Figure 6-1 Component Tray Removal for Chassis With a Safety Latch**

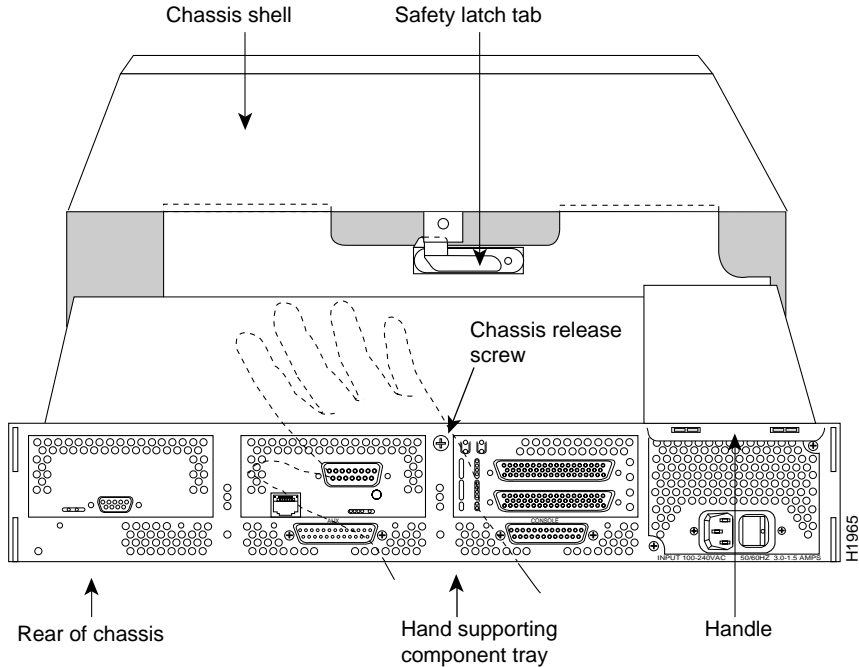

**Step 6** Support the component tray with one hand, push down on the safety latch tab, and pull the component tray out the rest of the way.

**Step 7** Set the component tray on your work surface.

### Removing the Component Tray from a Chassis without a Safety Latch

Take the following steps to remove the component tray from a chassis without a safety latch:

**Step 1** Turn OFF the system power.

**Step 2** Put on your ESD-preventive wrist strap.

## Accessing the Internal Components of the Router

---

- Step 3** Remove all network and power cables.
- Step 4** Loosen the nonremovable chassis release screw on the rear panel of the chassis. (See Figure 6-2.)

**Figure 6-2** Component Tray Removal for Chassis Without a Safety Latch

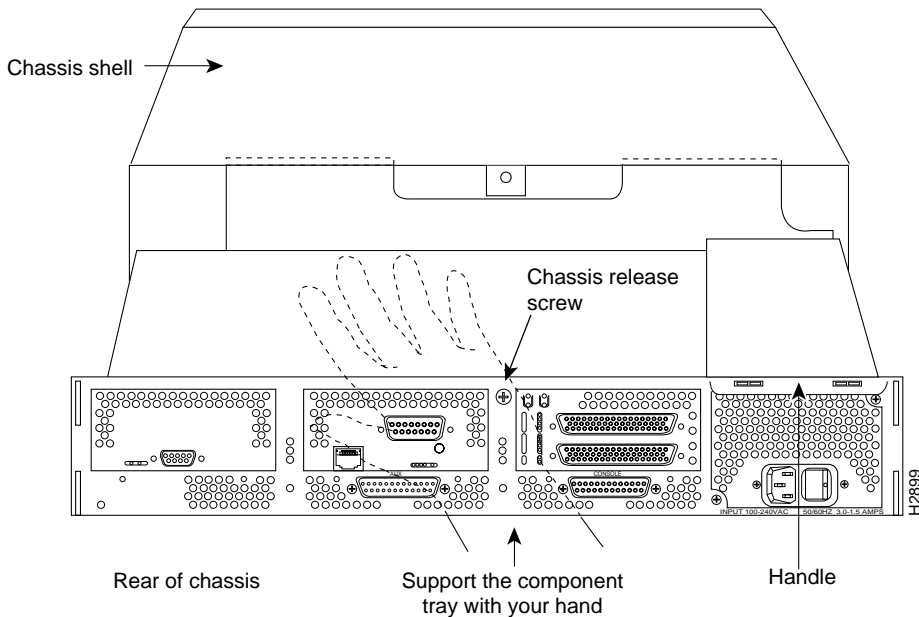

**Caution** Support the component tray from underneath, either on your work surface or with your hands, to prevent it from falling.

- Step 5** Pull on the handle located on the upper right corner of the chassis to slide the component tray out of the chassis shell while you support the component tray with one hand.
- Step 6** Set the component tray on your work surface.

## Replacing Network Processor Modules

When you have removed the component tray from the router, you can remove or add network processor modules. If you are replacing shared memory single in-line memory modules (SIMMs), you must first remove the network processor modules.

### Removing Network Processor Modules



**Caution** Some network processor modules are secured to the rear of the chassis with two external screws. On modules with external rear mounting screws, including multimode Fiber-Distributed Data Interface (FDDI) modules, these screws must be removed before the module can be safely lifted out of the chassis.

Take the following steps to remove a network processor module:

- Step 1** Orient the component tray as shown in Figure 6-3, then remove the module mounting screw from the top of the network processor module. Remove the two external rear mounting screws if the module has them. Set the screws aside.
- Step 2** Grasp the network processor module handle and pull it straight up to lift the module out of its connector. (See Figure 6-4.)
- Step 3** Place the removed module on an ESD mat.

Figure 6-3 Cisco 4000-M Component Tray—Typical of Cisco 4000 Series

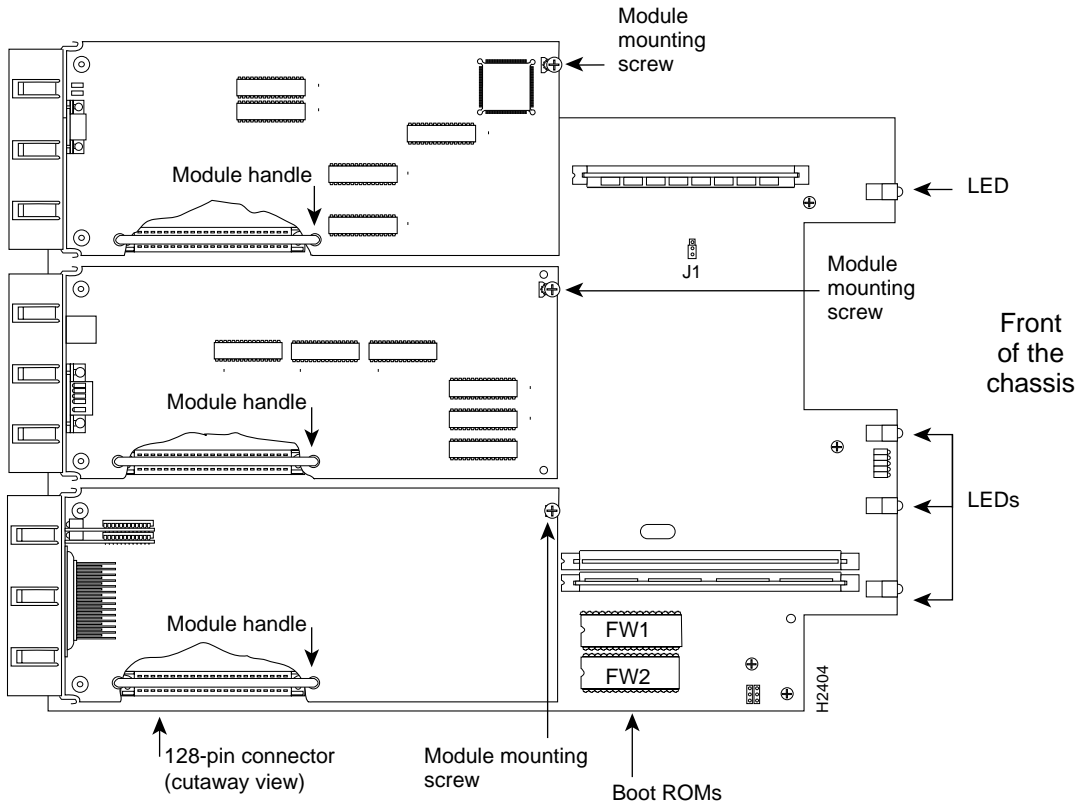

**Caution** Do not wiggle the handle when handling the network processor module, and do not exert any side-to-side pressure because the handle might work loose and damage the network processor module.

Figure 6-4 Network Processor Module Components

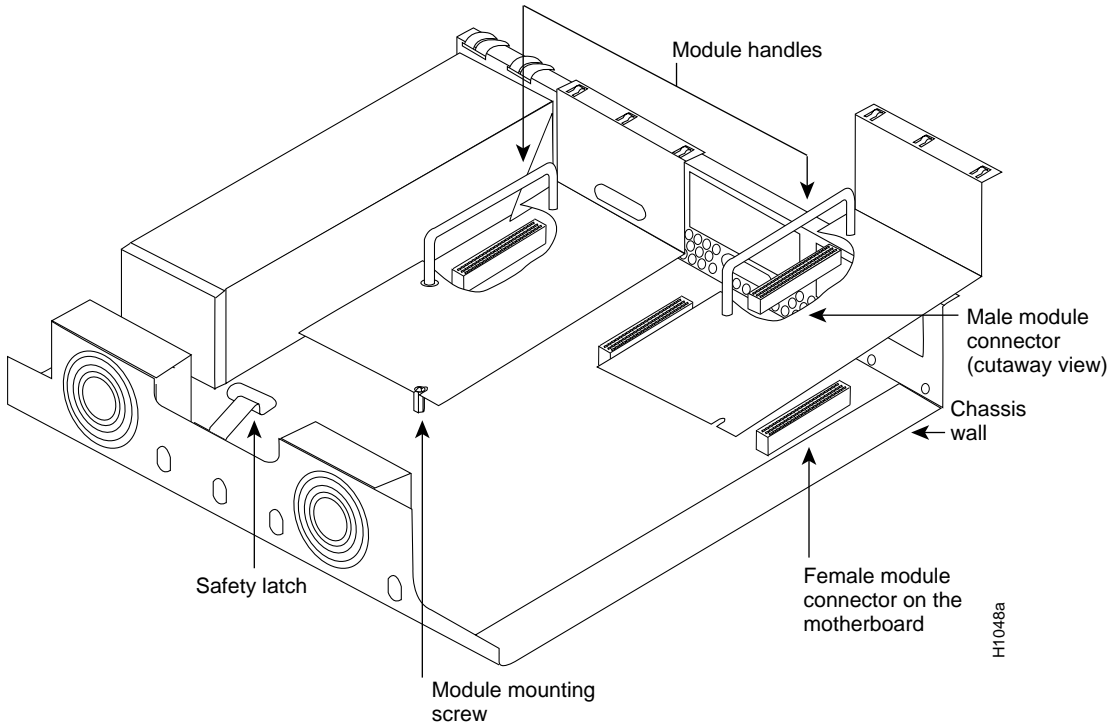

## Installing Network Processor Modules

Take the following steps to install a network processor module:

- Step 1** For all modules except for the NP-2T16S, hold the module by its handle, align it with the grooves in the chassis (not shown) and over its connector, and push the module lightly against the chassis wall. (See Figure 6-4.)

For NP-2T16S modules, hold the module as shown in Figure 6-5 at an angle with its faceplate lower than the other end. Then slip the upper 200-pin connector through the opening in the back panel of the chassis. Make sure the

flange of the module extends over the top of the chassis. Then rotate the module, moving it downward and forward until the module connector is aligned with the motherboard connector.

**Figure 6-5**      **Aligning the 2T16S Network Processor Module with the Chassis**

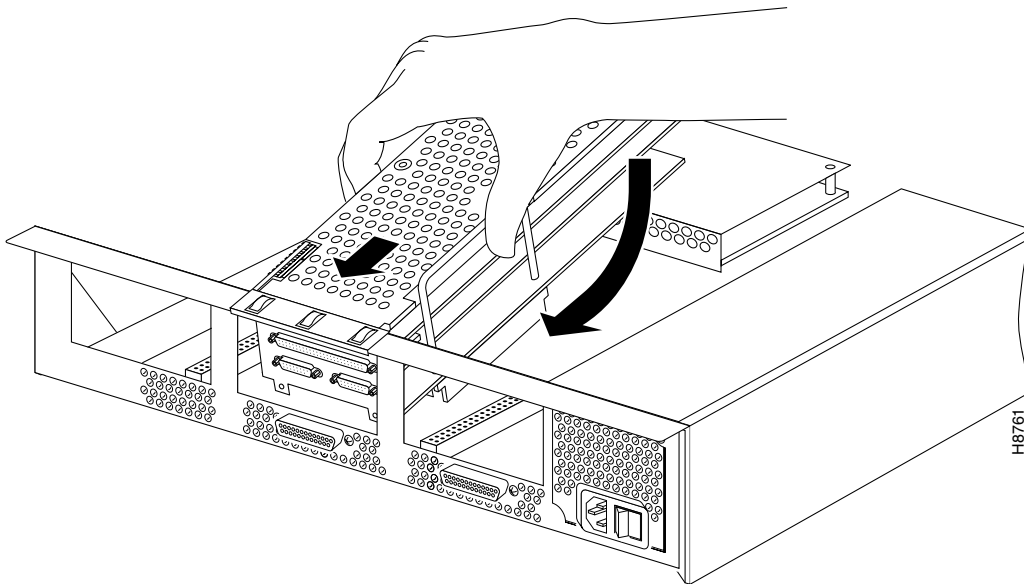

**Step 2**      Push the network processor module gently into place without bending the connector pins, inserting the male connector into the female connector on the motherboard.

For NP-2T16S modules, press on the module as shown in Figure 6-6, first at point A and then point B. With a small amount of force, the connectors snap together.

Figure 6-6 Pressing the 2T16S Network Processor Module into Place

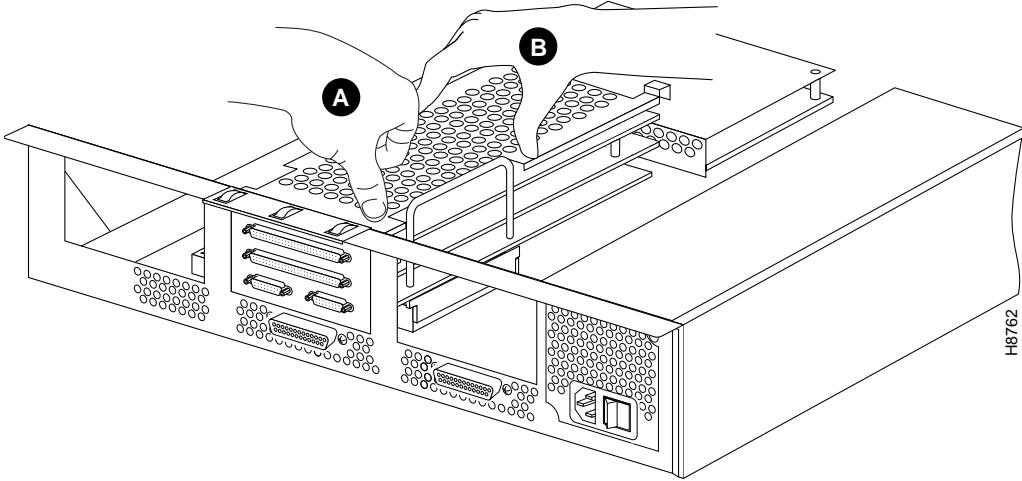

**Step 3** Make sure that the connector on the module is correctly seated on the female connector on the motherboard. (See Figure 6-8.)

## Figure 6-7 Correct Installation of the Network Processor Module

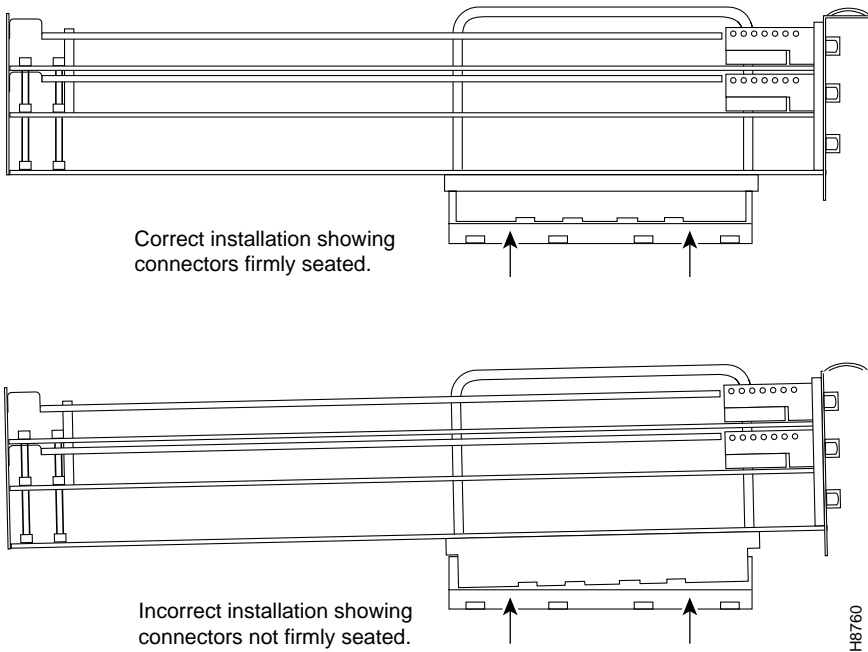

**Caution** If any of the network processor module cards have daughter cards projecting at right angles to the module (see Figure 6-8), be careful not to cause the module to bow during installation; otherwise the daughter cards can become disconnected. If this happens, carefully reseat the daughter card connectors by handling the card by its edges without touching any of the components on the card.

Figure 6-8 Network Processor Module Daughter Card Installation

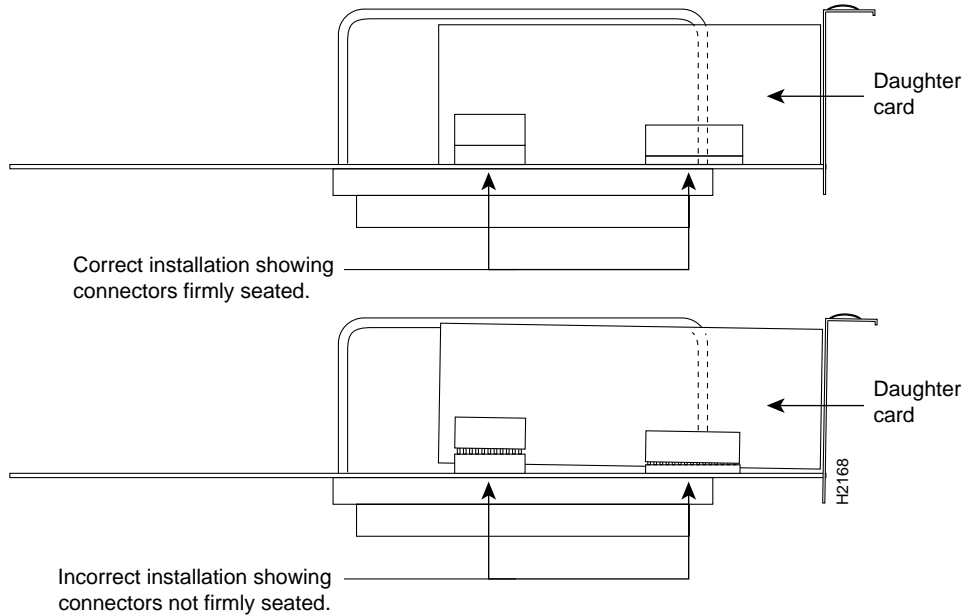

**Step 4** Replace the module mounting screw in its place on the end of the network processor module. (See Figure 6-4.)



**Caution** Do not overtighten the module mounting screw. The network processor module or the underlying motherboard could be damaged. The maximum screw torque is 7 inch-lb.

**Step 5** Replace the external rear mounting screws, if used, to attach the module to the rear of the chassis.

**Step 6** Replace the module mounting screw in its place on the end of the network processor module. (See Figure 6-3.)

**Step 7** Replace external rear mounting screws, if used, to attach the module to the rear of the chassis.



**Caution** Do not overtorque the screws because they might damage the network processor module or the underlying motherboard. The maximum screw torque is 7-inch-lb.

## Replacing the Component Tray

Take the following steps to replace the component tray in the chassis shell:

- Step 1** Reinsert the component tray into the chassis shell, pushing on the back of the tray while at the same time pressing on the chassis release screw with the thumb of your right hand. (See Figure 6-2.)
- Step 2** Retighten the chassis release screw.

## Use of the Slot Filler Panel

If the router is configured with fewer than three network processor modules, you must place a slot filler panel in the open slot to ensure proper airflow. Figure 6-9 shows a slot filler panel.

**Figure 6-9 Slot Filler Panel**

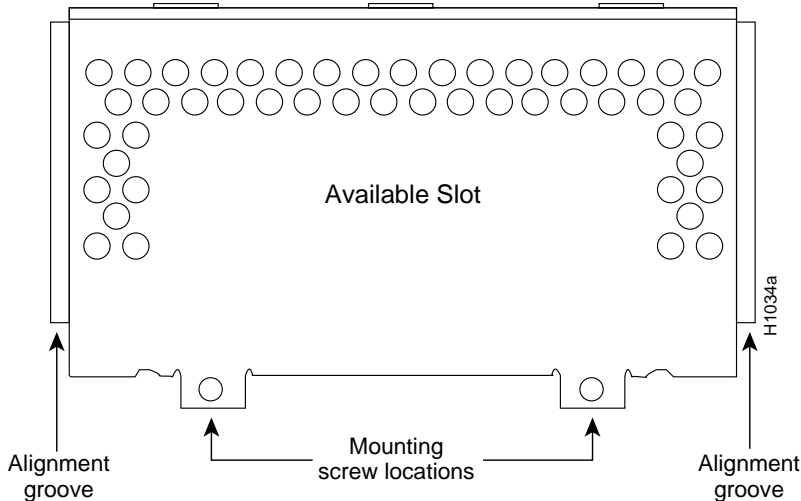

## Problem Solving

The key to problem solving in this system is to try to isolate the problem to a specific subsystem. By comparing what the system is doing to what it should be doing, the task of isolating a problem is greatly simplified.

When problem solving, consider the following subsystems of the router:

- Power system—Includes the power supply and the wiring.
- Cooling system—The blower assembly should go on when you power up the router.
- Network processor modules—Problems with these modules can be the most difficult to troubleshoot. You can use the LEDs on the network processor modules to help identify a failure. For complete information on LEDs, refer to the section “LEDs” later in this appendix.
- System cables—Includes all of the external cables that connect the router to the network.

### Troubleshooting the Power and Cooling Systems

Check the following items to help isolate the problem:

- With the power switch on, is the power LED on the front panel on?
  - If not, check the AC input, AC source, router circuit breaker, and the power supply cable to make sure they are securely connected.
  - If the power LED is still off, the problem might be a power supply failure.
- Does the system shut down after being on a short time?
  - Check the fan. If the fan is not working, the system will overheat and shut itself down.
  - Check the environmental site requirements in the section “General Site Requirements” in the chapter “Preparing to Install the Router” and ensure that the chassis intake and exhaust vents are clear.

### Troubleshooting the Network Processor Modules and Cables

Check for the following symptoms to help isolate the problem:

- Network processor module is not recognized by the system when you use the Cisco IOS **show version** command.
  - Check the front panel OK LED for the module. The OK LED should be on.
  - Check the LEDs on the network processor module.
  - Check to make sure the network processor module’s connection to the motherboard is fully seated.
  - If the module has one or more daughter boards, check to make sure their connections to the module are correctly seated.
  - Check that the correct software version is installed. Refer to the section “Software Compatibility” in the chapter titled “Overview.”
- Network processor module is recognized when you use the **show interface** command, but interface port(s) will not initialize.

- Check to make sure the network processor module's connection to the motherboard is fully seated.
- Check the external cables to make sure they are securely connected.
- Use the **show interface** command to make sure the module is not administratively shut down.
- System will not boot properly, or constantly or intermittently reboots.
  - Check to make sure the network processor module's connection to the motherboard is fully seated.
  - Check that the correct software version is installed. Refer to the section “Software Compatibility” in the chapter titled “Overview.”
  - Remove and then replace each network processor module one at a time. While each module is removed, reboot the system. If the system boots properly with one of the modules removed, the module might be at fault.
- System boots, but the console screen is frozen.
  - Check the external console connection to make sure it is secure.
  - Verify that you are using the correct console baud rate in the documentation for the terminal.

## Environmental Reporting Features

If the router is operating at an abnormally high temperature, the following message will be displayed on the console screen:

```
%SYS-1-OVERTEMP: System detected OVERTEMPERATURE condition. Please  
resolve cooling problem immediately!
```

Typical causes of an abnormally high system temperature are as follows:

- Fan failure
- Air blockage to cooling vents
- Air conditioner failure in the room where the router is located

## LEDs

On the front panel, the three LEDs labeled OK correspond to the three network processor modules, if present, and show their status. The upper LEDs labeled DATA blink to show network activity on the interfaces of each module.

The LED labeled POWER shows that the system card's power is on, and the OK LED shows that the processor is working.

The network processor module LEDs are all visible through cutouts in the rear of the chassis. For module LED descriptions, refer to the configuration notes shipped with the router and the spare modules.

## Technical Assistance

If you cannot locate the source of a problem and need technical assistance, contact Cisco's Technical Assistance Center (TAC) at 800 553-2447, 408 526-7209, or [tac@cisco.com](mailto:tac@cisco.com). Before you contact Cisco, have the following information ready:

- Chassis type and serial number
- Maintenance agreement or warranty information
- Type of software and version number
- Date you received the new chassis
- Brief description of the problem you are having
- Brief explanation of what steps you have taken to isolate the problem