



Configuring Cisco MC3810–IGX Interworking for Scaling Large Networks



Caution

Beginning with Cisco IOS Releases 12.0(7)XK and 12.1(2)T, this feature is no longer supported.

Using the Cisco MC3810–IGX Interworking functionality, you can configure the Cisco MC3810 multiservice access concentrator to act as an access device to the IGX 8400 switch. On the Cisco MC3810, a frame trunk card (FTC) trunk port is configured to send traffic to the IGX frame trunk module (FTM) port using the network management system (NMS) protocol. Using IGX Interworking, you can scale large networks of Cisco MC3810 concentrators to IGX 8400 switches.



Note

This chapter provides only configuration information for the Cisco MC3810. For information about IGX switch configuration and commands, see the *Cisco WAN Switching Command Reference* for version 9.1.

Cisco MC3810–IGX Interworking supports the following functionality:

- One FTC trunk port to the IGX can be configured on each Cisco MC3810.
- Up to 100 connections over the FTC trunk port are supported on the Cisco MC3810.
- Data traffic such as Frame Relay and frame forwarding can be sent from the Cisco MC3810 to through the FTM to the Frame Relay module (FRM) port on the IGX.
- Voice traffic from the Cisco MC3810 to the IGX can be sent in the following cases:
 - With Voice Activity Detection (VAD) enabled, up to 10 channels of ADPCM 32K (G.726) voice can be sent to the IGX channelized voice module (CVM)/ universal voice module (UVM).
 - With VAD disabled, up to 6 channels of ADPCM 32K (G.726) voice can be sent to the IGX CVM/UVM.
 - Up to 12 channels of G.729 voice and up to 24 channels of G.729a voice can be sent to the IGX UVM.
 - Transparent signaling for analog/digital receive and transmit (E&M) immediate, analog/digital E&M wink, and analog Foreign Exchange Station (FXS) voice can be sent to the IGX CVM/UVM.
- FAX traffic up to 9.6 kbps can be sent to the IGX UVM.

You can configure up to 255 Cisco MC3810 concentrators to a single IGX 8400 switch. Depending on the application, the data and voice connections terminate on different IGX modules. The Cisco MC3810–IGX Interworking feature requires that the IGX 8400 switch run Version 9.1 or later.

Figure 14-1 shows an example of voice and data interworking between the Cisco MC3810 and an IGX network.

Figure 14-1 Voice and Data Interworking between the Cisco MC3810 and an IGX Network

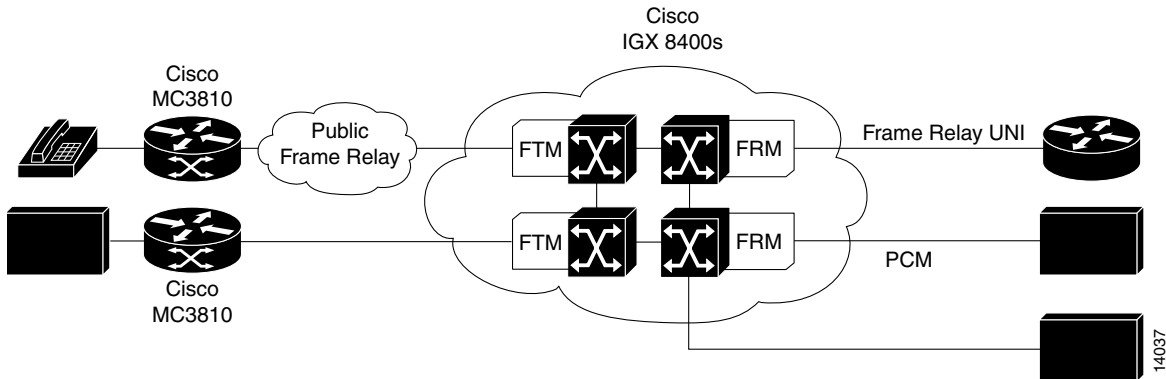
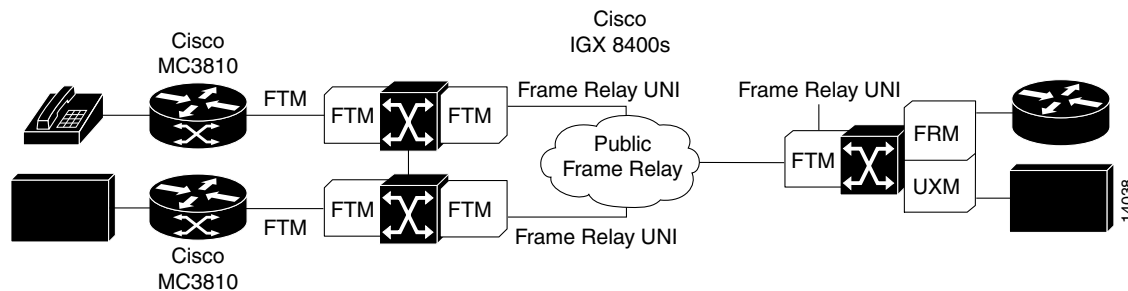

Figure 14-2 shows an example of multiple Cisco MC3810 concentrators terminating to an IGX 8400 switch acting as a concentration node.

Figure 14-2 Multiple Cisco MC3810 Concentrators Terminating at a Single IGX 8400 Switch



Configuring Cisco MC3810–IGX Interworking

When you configure IGX interworking on the Cisco MC3810, you must configure one interface to serve as the FTC trunk, and then you configure the specific connections over that FTC trunk.

This section is divided into the following sections:

- [Configuring the Cisco MC3810 FTC Management DLCI, page 14-3](#)
- [Configuring the Cisco MC3810 FTC Frame Relay DLCI for Data Traffic \(Optional\), page 14-5](#)
- [Configuring the Cisco MC3810 FTC Voice DLCI for Voice Connections \(Optional\), page 14-7](#)

This section assumes that you have already configured the following:

- Frame Relay interfaces
- Voice over Frame Relay dial peers
- Voice ports

Configuring the Cisco MC3810 FTC Management DLCI

The Cisco MC3810 FTC management data link connection identifier (DLCI) is required when configuring Cisco MC3810–IGX Interworking. You can only have one FTC management DLCI on each Cisco MC3810, but that management DLCI can also carry data and/or voice connections, or can carry data and/or voice connections in conjunction with a Frame Relay trunk or a voice DLCI. You can configure the FTC management DLCI and the FTC Frame Relay and FTC voice DLCIs in the following combinations:

- FTC management DLCI only (management traffic + data traffic and/or voice traffic)
- FTC management DLCI (management traffic + voice traffic) + FTC Frame Relay DLCI (data traffic)
- FTC management DLCI (management traffic + data traffic) + FTC voice DLCI (voice traffic)
- FTC management DLCI (management traffic) + FTC Frame Relay DLCI (data traffic) + FTC voice DLCI (voice traffic)

Regardless of the combination, you can configure up to 100 connections over the FTC trunk port.



Note

Whether you configure data traffic and/or voice traffic on the FTC management DLCI depends on your configuration needs. For example, configuring data traffic and voice traffic on the FTC management DLCI allows you to use one DLCI, saving you money if you are charged for each DLCI. On the other hand, configuring data traffic over an FTC Frame Relay DLCI, or voice traffic over an FTC voice DLCI, allows you to isolate the traffic types for greater control and quality of service over the WAN.

To configure the Cisco MC3810 FTC management DLCI to the IGX 8400 frame trunk module (FTM), perform the following tasks on the Cisco MC3810 beginning in configuration mode:

Step	Command	Purpose
1	<pre>router(config)# interface serial {0 1} router(config)# interface serial 0:x</pre>	<p>If configuring the FTC trunk on serial interface 0 or 1, enter interface configuration mode.</p> <p>If configuring the FTC trunk over the T1/E1 trunk, enter interface configuration mode, where <i>x</i> indicates the channel group number.</p>
2	<pre>router(config-if)# encapsulation ftc-trunk</pre>	<p>Enable FTC trunk encapsulation on the interface.</p> <p>Note You can have only one interface on the Cisco MC3810 configured as the FTC trunk at one time.</p>

Step	Command	Purpose
3	<pre>router(config-if)# ftc-trunk management-dlci <i>dlci</i> [remote-management-dlci <i>dlci</i>]</pre>	<p>Map the FTC trunk to an existing management data link connection identifier (DLCI).</p> <p>Enter the remote-management-dlci value if there is a public Frame Relay cloud between the Cisco MC3810 FTC port and the IGX FTM port. Enter this option only if the local DLCI and the remote DLCI are not the same.</p> <p>Note The DLCI (or the remote DLCI if configured) must match the DLCI on the IGX switch configured using the IGX addad command.</p>
4	<pre>router(config-if)# ftc-trunk management-protocol {normal inverted}</pre>	<p>Select the mode that the management frames are sent.</p> <p>Use normal mode when the Cisco MC3810 is connected to the IGX switch. When two Cisco MC3810 concentrators are connected back-to-back, use inverted mode on one concentrator; the other concentrator should be set to normal mode.</p>

You have a choice of how to proceed from here. Choose one of the following options:

- To configure data connections over a separate FTC Frame Relay DLCI, proceed to the “[Configuring the Cisco MC3810 FTC Frame Relay DLCI for Data Traffic \(Optional\)](#)” section on page 14-5.
- To configure voice connections over a separate FTC voice DLCI, proceed to the “[Configuring the Cisco MC3810 FTC Voice DLCI for Voice Connections \(Optional\)](#)” section on page 14-7.
- To configure all your data and voice connections on the FTC management DLCI, continue this procedure.

To continue this procedure to configure all your data and voice connections on the FTC management DLCI, perform the following tasks:

Step	Command	Purpose
5	<pre>router(config)# connect interface dlci <i>dlci</i> <i>ftc-trunk</i> connection-id <i>cid</i></pre>	<p>(Optional) Configure a data connection between the Cisco MC3810 and the IGX switch that will travel over the FTC management DLCI.</p> <p>For the <i>ftc-trunk</i> value, enter the interface that the FTC trunk was configured on. For example, if you configured serial 0 as the FTC trunk, enter serial 0 for the <i>ftc-trunk</i> value.</p>
6	<pre>router(config)# connect voice dial-peer-tag <i>ftc-trunk</i> connection-id <i>cid</i></pre>	<p>(Optional) Configure a voice connection between a voice dial-peer and the IGX switch that will travel over the FTC management DLCI.</p> <p>The dial peer can be either a POTS dial peer or a Voice over Frame Relay dial peer.</p>
7	Repeat step 5 or step 6 for each data or voice connection over the FTC management DLCI.	

Configuring the FTC Management DLCI on the Cisco IGX 8400 Switch

For Frame Relay management DLCI connections on the IGX FTM card, use the following command syntax to add the Frame Relay management trunk connection(s) to the Cisco MC3810:

```
addad <slot.port> <access_device_ID> <management DLCI>
```

The management DLCI must match the DLCI or remote-management DLCI configured using the Cisco MC3810 **ftc-trunk management-dlci** command.



Note

The Cisco IGX switch command syntax differs from Cisco IOS command syntax. Items in brackets (< >) are required command arguments. Items in square brackets ([]) are optional command arguments. These commands are based on Cisco IGX System Software Release 9.1. For more information about IGX switch configuration and commands, see the *Cisco WAN Switching Command Reference*.

Configuring the Cisco MC3810 FTC Frame Relay DLCI for Data Traffic (Optional)

In addition to the FTC management DLCI, you can optionally configure an FTC Frame Relay DLCI for data traffic. The FTC Frame Relay data travels over the FTC management DLCI configured in the previous section.

To configure the Cisco MC3810 FTC Frame Relay DLCI to support data connections to the IGX 8400 switch, perform the following tasks on the Cisco MC3810 beginning in configuration mode:

Step	Command	Purpose
1	<pre>router(config)# interface serial {0 1} router(config)# interface serial 0:x</pre>	<p>If configuring the FTC trunk on serial interface 0 or 1, enter interface configuration mode.</p> <p>If configuring the FTC trunk over the T1/E1 trunk, enter interface configuration mode, where <i>x</i> indicates the channel group number.</p> <p>Note Enter the same interface that you created the FTC Trunk on. Make sure the interface is set to encapsulation ftc-trunk.</p>
2	<pre>router(config-if)# ftc-trunk frame-relay-dlci dlci [remote-frame-relay-dlci dlci]</pre>	<p>Map the FTC Frame Relay DLCI to an existing Frame Relay data-link connection identifier (DLCI).</p> <p>Enter the remote-management-dlci value if there is a public Frame Relay cloud between the Cisco MC3810 FTC port and the IGX FTM port. Enter this option only if the local DLCI and the remote DLCI are not the same.</p> <p>Note Do not enter the same DLCI that was assigned to the FTC management DLCI.</p>

Repeat this procedure on each Cisco MC3810 that will send data traffic to an IGX 8400 switch via an FTC Frame Relay DLCI.

After the Frame Relay FTC DLCI is configured, you can now establish connections over the FTC trunk. For more information about the connection procedures, see one of the following sections:

- [Configuring the Cisco MC3810 Frame Relay Data Connection over the FTC Trunk, page 14-6](#)

- [Configuring the Cisco MC3810 Frame Forward Connection over the FTC Trunk, page 14-6](#)
- [Configuring the Cisco MC3810 IP Routing Connection over the FTC Trunk, page 14-7](#)

Configuring the Cisco MC3810 Frame Relay Data Connection over the FTC Trunk

To configure the connection between the Cisco MC3810 Frame Relay DLCI and the FTC trunk, perform the following tasks on the Cisco MC3810 beginning in configuration mode:

Step	Command	Purpose
1	<pre>router(config)# connect interface dlci dlci ftc-trunk connection-id cid</pre>	Configure a connection between the DLCI and the FTC trunk. For the <i>ftc-trunk</i> value, enter the interface that the FTC trunk was configured on. For example, if you configured serial 0 as the FTC trunk, enter serial 0 for the <i>ftc-trunk</i> value.
2	Repeat step 1 for each data connection over the FTC Frame Relay trunk.	

For information on configuring the data channels on the IGX switch, see the [“Configuring the Data Channels on the IGX Switch”](#) section on page 14-7.

Configuring the Cisco MC3810 Frame Forward Connection over the FTC Trunk

When you configure a Frame Forward connection over the FTC trunk, the encapsulation for the source port must be High-Level Data Link Control (HDLC).

To configure a Frame Forward connection over the FTC trunk, perform the following tasks on the Cisco MC3810 beginning in configuration mode:

Step	Command	Purpose
1	<pre>router(config)# interface serial {0 1}</pre>	Enter serial interface configuration mode. Note This interface is not the FTC trunk interface.
2	<pre>router(config-if)# encapsulation hdlc</pre>	Enable HDLC encapsulation on the interface.
3	<pre>router(config)# connect interface dlci dlci ftc-trunk connection-id cid</pre>	Configure a connection between the DLCI and the FTC trunk. For the <i>ftc-trunk</i> value, enter the interface that the FTC trunk was configured on. For example, if you configured serial 0 as the FTC trunk, enter serial 0 for the <i>ftc-trunk</i> value.
4	Repeat step 3 for each data connection over the FTC Frame Relay trunk.	

For information on configuring the data channels on the IGX switch, see the [“Configuring the Data Channels on the IGX Switch”](#) section on page 14-7.

Configuring the Cisco MC3810 IP Routing Connection over the FTC Trunk

When you configure an IP routing connection over the FTC trunk, you must use the special `switch0` designation on the interface:

Step	Command	Purpose
1	<code>router(config)# interface switch0</code>	Enter interface configuration mode for Switch0. Note On the Cisco MC3810, you must configure IP routing on the <code>switch0</code> logical interface.
2	<code>router(config-if) frame-relay map ip ip-address dlci</code>	Map the Frame Relay DLCI to the IP address.
3	<code>router(config)# connect switch0 dlci dlci ftc-trunk connection-id cid</code>	Configure an IP routing connection between the DLCI and the FTC trunk. Make sure to specify <code>switch0</code> as the local IP interface. For the <code>ftc-trunk</code> value, enter the interface that the FTC trunk was configured on. For example, if you configured serial 0 as the FTC trunk, enter serial 0 for the <code>ftc-trunk</code> value.
4	Repeat step 3 for each IP routing data connection over the FTC Frame Relay trunk.	

For information on configuring the data channels on the IGX switch, see the “[Configuring the Data Channels on the IGX Switch](#)” section on page 14-7.

Configuring the Data Channels on the IGX Switch

For Frame Relay connections on the IGX switch, use the following command syntax to add the Frame Relay connection(s) to the Cisco MC3810:

```
addcon <local_channel> <remote_node> <remote_channel> [con_type] <frame_relay_class |
[individual parameters]> [route_avoid]
```



Note

The Cisco IGX switch command syntax differs from Cisco IOS command syntax. Items in brackets (<>) are required command arguments. Items in square brackets ([]) are optional command arguments. These commands are based on Cisco IGX System Software Release 9.1. For more information about IGX switch configuration and commands, see the *Cisco WAN Switching Command Reference*.

Configuring the Cisco MC3810 FTC Voice DLCI for Voice Connections (Optional)

In addition to the FTC management DLCI, you can optionally configure an FTC voice DLCI for voice traffic. The FTC voice traffic travels over the FTC management DLCI configured in the previous section.

To configure the FTC voice DLCI to support voice connections to the IGX 8400 switch, perform the following tasks on the Cisco MC3810 beginning in configuration mode:

Step	Command	Purpose
1	<pre>router(config)# interface serial {0 1} router(config)# interface serial 0:x</pre>	<p>If configuring the FTC trunk on serial interface 0 or 1, enter interface configuration mode.</p> <p>If configuring the FTC trunk over the T1/E1 trunk, enter interface configuration mode, where <i>x</i> indicates the channel group number.</p> <p>Note Enter the same interface that you created the FTC management trunk on. Make sure the interface is set to encapsulation ftc-trunk.</p>
2	<pre>router(config-if)# ftc-trunk voice-dlci dlci [remote-voice-dlci dlci]</pre>	<p>Map the FTC trunk to an existing Frame Relay DLCI.</p> <p>Enter the remote-management-dlci value if there is a public Frame Relay cloud between the Cisco MC3810 FTC port and the IGX FTM port. Enter this option only if the local DLCI and the remote DLCI are not the same.</p> <p>Note Do not enter the same DLCI that was assigned to the FTC management DLCI.</p> <p>For more information about VoFR, see Chapter 5, “Configuring Voice over Frame Relay.”</p>
3	<pre>router(config)# connect voice dial-peer-tag ftc-trunk connection-id cid</pre>	<p>Configure a connection between a voice dial peer and the FTC trunk.</p> <p>The dial peer can be either a POTS dial peer or a VoFR dial peer. When making a connection from a Cisco MC3810 to an IGX UVM or CVM, use a POTS dial peer (the connection ID must be an even number). When making a connection from a Cisco MC3810 to a second Cisco MC3810, use a VoFR dial peer.</p> <p>For the <i>ftc-trunk</i> value, enter the interface that the FTC trunk was configured on. For example, if you configured serial 0 as the FTC trunk, enter serial 0 for the <i>ftc-trunk</i> value.</p>
4	Repeat step 3 for each dial peer that will be connected over the FTC voice trunk.	

Repeat this procedure on each Cisco MC3810 that will send voice traffic to an IGX 8400 switch via an FTC voice DLCI.

For information on configuring the voice channels on the IGX switch, see the next section “[Configuring the Voice Channels on the IGX Switch.](#)”

Configuring the Voice Channels on the IGX Switch

For voice connections on the IGX switch, use the following command syntax to add connections to the Cisco MC3810:

```
addcon <local_channel> <remote node> <remote channel> <type> [avoid]
```

When configuring the voice channels, make sure the same voice compression mode that was configured on the Cisco MC3810 using the `codec` command is configured on the IGX voice channels. For example, if the `codec` command was set to `g729ar8` on the Cisco MC3810 voice port, make sure that the UVM connection is also configured to support `g729ar8` compression.

**Note**

The Cisco IGX switch command syntax differs from Cisco IOS command syntax. Items in brackets (< >) are required command arguments. Items in square brackets ([]) are optional command arguments. These commands are based on Cisco IGX System Software Release 9.1. For more information about IGX switch configuration and commands, see the *Cisco WAN Switching Command Reference*.

IGX Interworking Configuration Example

This section provides an example of how to configure the Cisco MC3810 to act as an access device to an IGX 8400 switch.

Figure 14-3 shows an example of two Cisco MC3810 concentrators connected to an IGX 8400 FTM, with other connections to the UVM through a PBX. The configuration examples following the figure include commands to set up the session connections, the voice PVC connections, routing through switch 0, Common Channel Signaling (CCS) frame forwarding support, the Cisco MC3810–UVM connections, and the Cisco MC3810–CVM connections.

Because the voice connections between the two Cisco MC3810 concentrators are over a Frame Relay network, VoFR dial peers must be configured on both concentrators. The session target configured on both concentrators should be the same.

Figure 14-3 Cisco MC3810–IGX Interworking Configuration Example

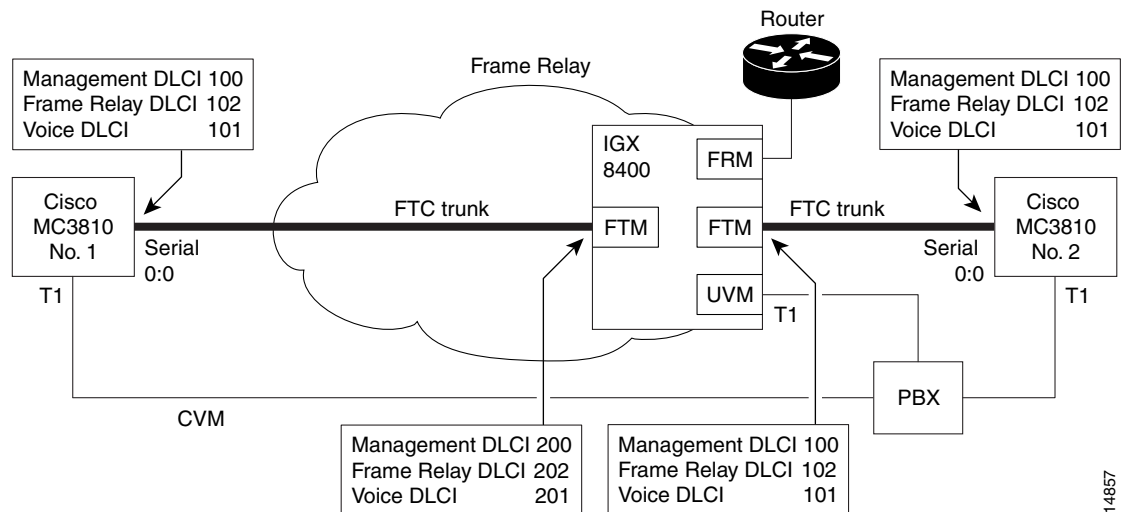

14857

Configuration on Cisco MC3810 No. 1

```

hostname router19

network-clock base-rate 56k
ip subnet-zero

controller T1 0
 framing esf
 linecode b8zs
 channel-group 0 timeslots 1-24 speed 64

controller T1 1
 mode cas
 voice-group 0 timeslots 1-2 type e&m-immediate-start
 voice-group 1 timeslots 3-4 type e&m-delay-dial
 voice-group 2 timeslots 5-6 type e&m-wink-start

connect Switch0 dlci 103 Serial0:0 connection-id 103
connect Voice4000 Serial0:0 connection-id 40
connect Voice2 Serial0:0 connection-id 50
connect Voice4 Serial0:0 connection-id 52
connect Voice6 Serial0:0 connection-id 54
connect Serial11 dlci 250 Serial0:0 connection-id 250

interface Ethernet0
 mac-address 0001.0101.0101
 ip address 10.10.10.51 255.255.255.0
 no ip directed-broadcast

interface Serial0
 no ip address
 no ip directed-broadcast
 no ip mroute-cache
 bandwidth 1536
 no keepalive
 shutdown
 hold-queue 1024 out

interface Serial11
 no ip address
 no ip directed-broadcast
 no keepalive
 clockrate 64000

interface Serial0:0
 no ip address
 no ip directed-broadcast
 encapsulation ftc-trunk
 no ip mroute-cache
 no keepalive
 ftc-trunk voice-dlci 101 remote-voice-dlci 201
 ftc-trunk frame-relay-dlci 102 remote-frame-relay-dlci 202
 ftc-trunk management-dlci 100 remote-management-dlci 200
 ftc-trunk management-protocol normal
 hold-queue 150 in
 hold-queue 1024 out

interface Switch0
 ip address 10.10.12.1 255.255.255.0
 no ip directed-broadcast

```

```
encapsulation frame-relay
no fair-queue
frame-relay map ip 10.10.11.51 103
frame-relay map ip 10.10.12.2 103
frame-relay map ip 10.10.11.197 103

interface FR-ATM20
no ip address
no ip directed-broadcast
shutdown

ip default-gateway 1.7.0.1
ip classless
ip route 0.0.0.0 0.0.0.0 1.7.0.1
ip route 10.10.11.51 255.255.255.255 Switch0
ip route 10.10.11.197 255.255.255.255 Switch0

line con 0
exec-timeout 0 0
transport input none
line aux 0
line 2 3
line vty 0 4
login

voice-port 1/1
codec g726r32

voice-port 1/2
codec g726r32

voice-port 1/3
codec g729r8

voice-port 1/4
codec g729r8

voice-port 1/5

voice-port 1/6

dial-peer voice 1 pots
destination-pattern 2001
port 1/1

dial-peer voice 2 pots
destination-pattern 2002
port 1/2

dial-peer voice 3 pots
destination-pattern 2003
port 1/3

dial-peer voice 4 pots
destination-pattern 2004
port 1/4

dial-peer voice 5 pots
destination-pattern 2005
port 1/5
```

```

dial-peer voice 6 pots
 destination-pattern 2006
 port 1/6

dial-peer voice 4000 vofr
 destination-pattern 4...
 session target Serial0:0 40

```

Configuration on Cisco MC3810 No. 2

```

hostname router21

network-clock base-rate 56k
ip subnet-zero

controller T1 0
 framing esf
 linecode b8zs
 channel-group 0 timeslots 1-24 speed 64

controller T1 1
 mode cas
 voice-group 0 timeslots 1-2 type e&m-immediate-start
 voice-group 1 timeslots 3-4 type e&m-delay-dial
 voice-group 2 timeslots 5-6 type e&m-wink-start

connect Switch0 dlci 103 Serial0:0 connection-id 103
connect Voice2000 Serial0:0 connection-id 40
connect Voice2 Serial0:0 connection-id 50
connect Voice4 Serial0:0 connection-id 52
connect Voice6 Serial0:0 connection-id 54
connect Serial11 dlci 250 Serial0:0 connection-id 250

interface Ethernet0
 ip address 10.10.11.51 255.255.255.0
 no ip directed-broadcast
 no ip route-cache
 no ip mroute-cache

interface Serial0
 no ip address
 no ip directed-broadcast
 no ip route-cache
 no ip mroute-cache
 no keepalive
 shutdown
 hold-queue 1024 out

interface Serial11
 no ip address
 no ip directed-broadcast
 no ip route-cache
 no ip mroute-cache
 no keepalive
 no fair-queue
 clockrate 64000
 hold-queue 1024 out

interface Serial0:0
 no ip address

```

```
no ip directed-broadcast
encapsulation ftc-trunk
no ip mroute-cache
no keepalive
ftc-trunk voice-dlci 101
ftc-trunk frame-relay-dlci 102
ftc-trunk management-dlci 100
ftc-trunk management-protocol normal
hold-queue 150 in
hold-queue 1024 out

interface Switch0
ip address 10.10.12.2 255.255.255.0
no ip directed-broadcast
encapsulation frame-relay
no fair-queue
frame-relay map ip 10.10.10.51 103
frame-relay map ip 10.10.12.1 103
frame-relay map ip 10.10.10.196 103

interface FR-ATM20
no ip address
no ip directed-broadcast
shutdown

ip default-gateway 1.7.0.1
ip classless
ip route 0.0.0.0 0.0.0.0 1.7.0.1
ip route 10.10.10.51 255.255.255.255 Switch0
ip route 10.10.10.196 255.255.255.255 Switch0

logging trap debugging

line con 0
exec-timeout 0 0
transport input none
line aux 0
line 2 3
line vty 0 4
password lab
login

voice-port 1/1
codec g726r32

voice-port 1/2
codec g726r32

voice-port 1/3
codec g729r8

voice-port 1/4
codec g729r8

voice-port 1/5

voice-port 1/6

dial-peer voice 1 pots
destination-pattern 4001
port 1/1

dial-peer voice 2 pots
destination-pattern 4002
```

```
port 1/2
dial-peer voice 3 pots
 destination-pattern 4003
port 1/3

dial-peer voice 4 pots
 destination-pattern 4004
port 1/4

dial-peer voice 5 pots
 destination-pattern 4005
port 1/5

dial-peer voice 6 pots
 destination-pattern 4006
port 1/6

dial-peer voice 2000 vofr
 destination-pattern 2...
 session target Serial0:0 40

end
```