

Overview of the Cisco 2517 and Cisco 2519

The Cisco 2517 and Cisco 2519 combines Token Ring hub and router capabilities with a built-in Integrated Services Digital Network (ISDN) Basic Rate Interface (BRI).

Both units incorporate an intelligent, workgroup Token Ring hub with sophisticated internetwork connectivity via its built-in WAN interfaces and the Cisco Internetwork Operating System (Cisco IOS software).

These hubs provide in a single unit the capabilities of a Token Ring unshielded twisted pair (UTP) concentrator, an intelligent Simple Network Management Protocol (SNMP) internetwork router, and an ISDN terminal adapter.

The hubs have the following features:

- 11 available Token Ring hub ports on the Cisco 2517, and 23 available Token Ring hub ports on the Cisco 2519.
- Ring In/Ring Out ports on the Cisco 2519.
- Cisco 2519 hub ports can be isolated into two distinct rings (ports 1-12 and ports 13-24)
- One hub port that can be switched between a local device or another hub.
- Hub ports and router interfaces that can be configured using a modem, local terminal, or a PC.
- SNMP-managed hub and router ports.
- One ISDN (two B channels, one D channel) BRI operating at 128 kbps, compatible with many ISDN BRI switch types such as N11, 5ESS, DMS100, NET3, NET5, VN2, VN3, 1TR6, TS013, and NTT.
- Two synchronous serial interfaces operating at up to 2 Mbps.
- Numerous Cisco IOS feature sets.

- One asynchronous serial interface for low-speed WAN access for dial-on-demand routing or dial backup connections. Dial-on-demand routing reduces the cost of wide-area access by making use of ISDN or serial dial-up lines as an alternative to costly leased lines.
- Intelligent in-band hub management with the router card allows you to manage the hub even if the ring is out of service.
- IBM LAN network management support. Full Media Access Control (MAC) layer IBM Token Ring management that is compliant with the IBM LAN Network Manager implementation.

Software for the management card is included in firmware that is accessible through the management card console port.

Figure 1-1 shows the Cisco 2517 12-port hub, and Figure 1-2 shows the Cisco 2519 24-port hub.

Figure 1-1 Cisco 2517 12-port Hub

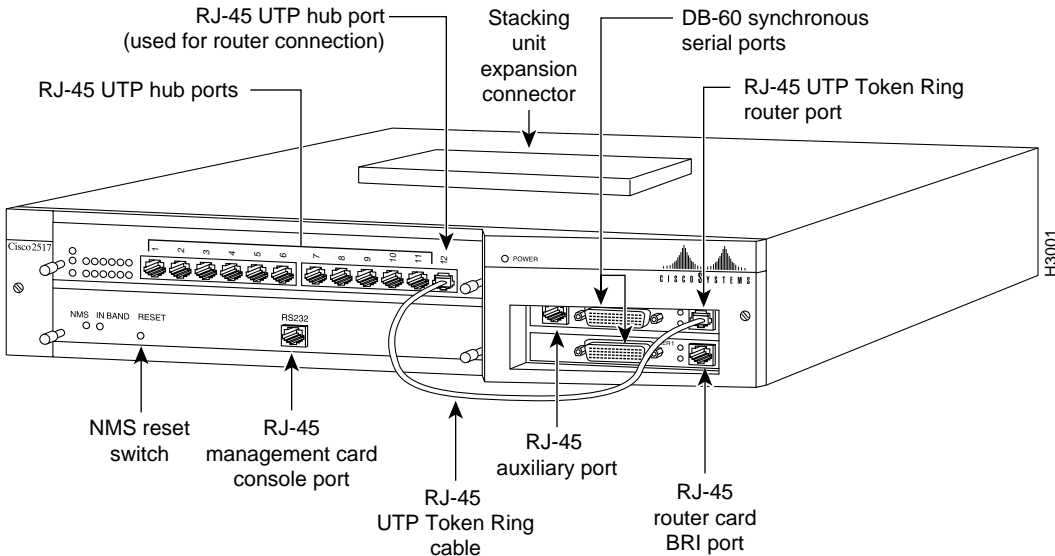
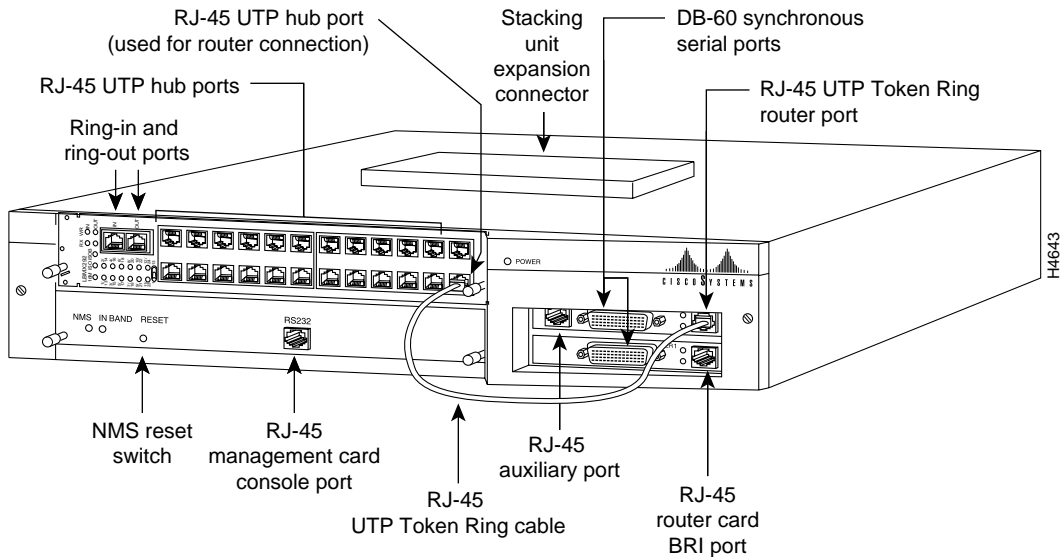

Figure 1-2 Cisco 2519 24-port Router/Hub



Note Do not attempt to operate the Cisco 2517 or Cisco 2519 without the stack expansion connector or an installed expansion unit.



Warning The ISDN connection is regarded as a source of voltage that should be inaccessible to user contact. Users should not attempt to tamper with or open any public telephone operator (PTO)–provided equipment or connection hardware. Any hardwired connection (other than by nonremovable, connect-one-time-only lug) must be made only by PTO staff or suitably trained engineers. Translated versions of this warning are in the appendix “Translated Safety Warnings.”



Warning The ports labeled “Ethernet,” “Token Ring,” and “AUX” are safety extra-low voltage (SELV) circuits. SELV circuits should only be connected to other SELV circuits. Because the BRI circuits are treated like telephone-network voltage, avoid connecting the SELV circuit to the telephone network voltage (TNV) circuits. Translated versions of this warning are in the appendix “Translated Safety Warnings.”

Hub Port Cards

The hub port card is a slide-in card in one of the following configurations:

- 12 Token Ring hub ports (11 available)
- 24 Token Ring hub ports (23 available)

Token Ring Hub Port Cards

Figure 1-2 shows the location of the hub port card in the chassis. Figure 1-3 shows the front of the 12-port Token Ring hub port card, and Figure 1-4 shows the 24-port Token Ring hub port card.

Figure 1-3 Cisco 2517 12-port Token Ring Hub Port Card

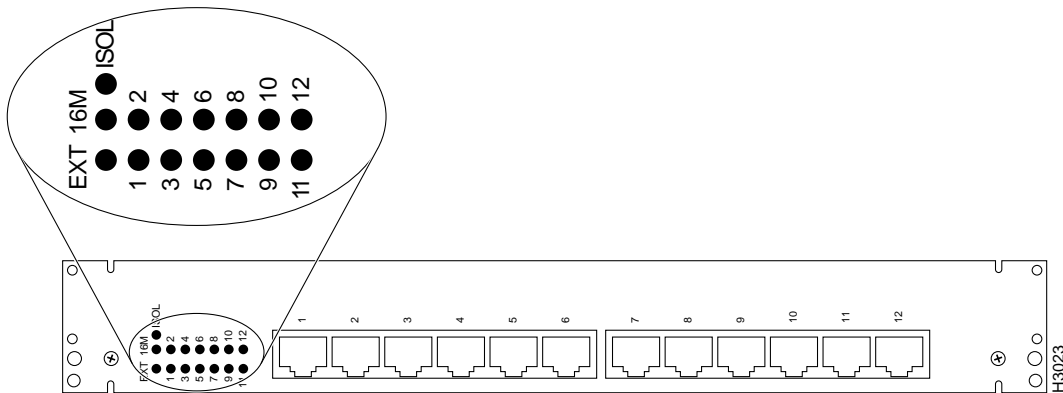
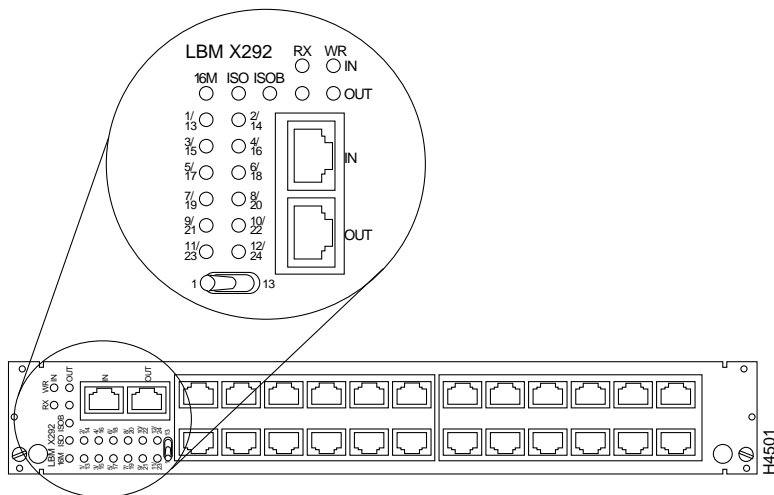

Figure 1-4 Cisco 2519 24-port Token Ring Hub Port Card

Token Ring Hub Port Card LEDs

The Token Ring hub port cards have an LED for the ring speed, port 1 mode, isolation mode, and each of the Token Ring hub ports. The 24-port hub port card has a toggle switch to display different banks of ports.

Table 1-1 lists and describes the Cisco 2517 LEDs. Table 1-2, Table 1-3, and Table 1-4 list and describe the Cisco 2519 LEDs.

Table 1-1 Cisco 2517 12-port Token Ring Hub Port Card LEDs

LED	Status	Description
EXT	On	Port 1 is set for hub-to-hub link.
	Off	Port 1 acts as a regular Token Ring port
16M	On	The ring speed is set to 16 Mbps.
	Off	The ring speed is set to 4 Mbps

Hub Port Cards

LED	Status	Description
ISOL	On	The hub port card is isolated from the backplane
	Off	The hub port card is connected to the backplane
Port LEDs	Green	An active station is connected to the port and is fully operational
	Red	An active station is connected to the port, and disconnected from the ring
	Off	No active station is connected

Table 1-2 Cisco 2519 24-port Token Ring Hub Port Card LEDs

LED	Status	Description
16M	On	Ring speed is set to 16 Mbps
	Off	Ring speed is set to 4 Mbps
ISOL (group isolation) The LED toggle switch determines whether the status for ports 1-12 or ports 13-24 are displayed.	On	The ports indicated with the toggle switch are isolated from the backplane
	Off	The ports indicated with the toggle switch are in normal mode
ISOB (backplane isolation)	On	The entire module is isolated from the backplane
	Off	The module is connected to the backplane
Port LEDs The LED toggle switch determines whether the status for ports 1-12 or ports 13-24 are displayed.	Green	An active station is connected to the port and is fully operational
	Red	An active station is connected to the port, but is disconnected from the ring
	Off	No active station is connected

Table 1-3 and Table 1-4 show the meaning of the Ring In and Ring out LEDs on the Cisco 2519. To read these tables, pick the state of the RX LED, and pick a state for the WR LED. Where the row and column intersect, read the meaning of the RX LED and WR LED combination.

Note You set the mode of the Ring In and Ring Out ports to MAU or Repeater mode with DIP switch settings on the hub port card. See the appendix “Cisco 2517 and Cisco 2519 Router/Hub Maintenance” for more information.

Table 1-3 Cisco 2519 Ring In and Ring Out LED Indicators: MAU Mode

RX LED	WR LED		
	Green	Red	Off
Green	Data rate error	Remote repeater module forced wrap mode	Data rate is valid
Red	Not applicable	IN port: not applicable OUT port: port is isolated (wrapped) by the network management station	Not applicable
Off	Not applicable	Port wrapped, no signal received	Not applicable

Table 1-4 Cisco 2519 Ring In and Ring Out LED Indicators: Repeater Mode

RX LED	WR LED		
	Green	Red	Off
Green	Data rate error	Operating mode error. This port is in MAU mode but the remote port is in repeater mode	Data rate is valid
Red	Not applicable	IN port: not applicable OUT port: port is isolated (wrapped) by the network management station	Not applicable
Off	Cable fault	Port wrapped, no signal received	IN port: Not applicable OUT port: no signal is circulating on the redundant path, assuming that the IN port has a valid data rate

Token Ring Hub Port Card DIP Switches and Port Impedance Jumper

A bank of DIP switches and a port impedance jumper are located on the hub port cards. See the section “Setting Hub Port Card DIP Switches and Jumper” in the appendix “Cisco 2517 and Cisco 2519 Router/Hub Maintenance” for more information.

Note You can override the switch settings with SNMP; however, when the hub is reset or the power is cycled, the DIP switch settings take effect.

Management Card

The management card is a removable card tray in the hub that has an integrated PC-AT compatible chip set and ISA bus. The router card and daughter card are inserted into the two ISA slots.

Figure 1-5 shows the front panel of the management card, and Table 1-5 describes the LEDs.

Figure 1-5 Management Card Front Panel

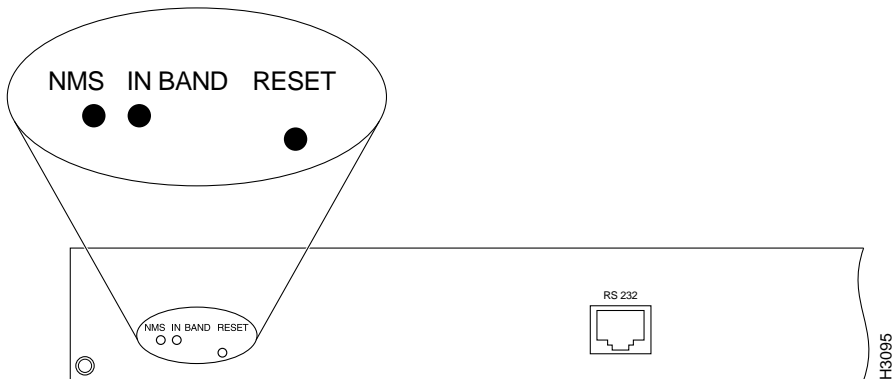
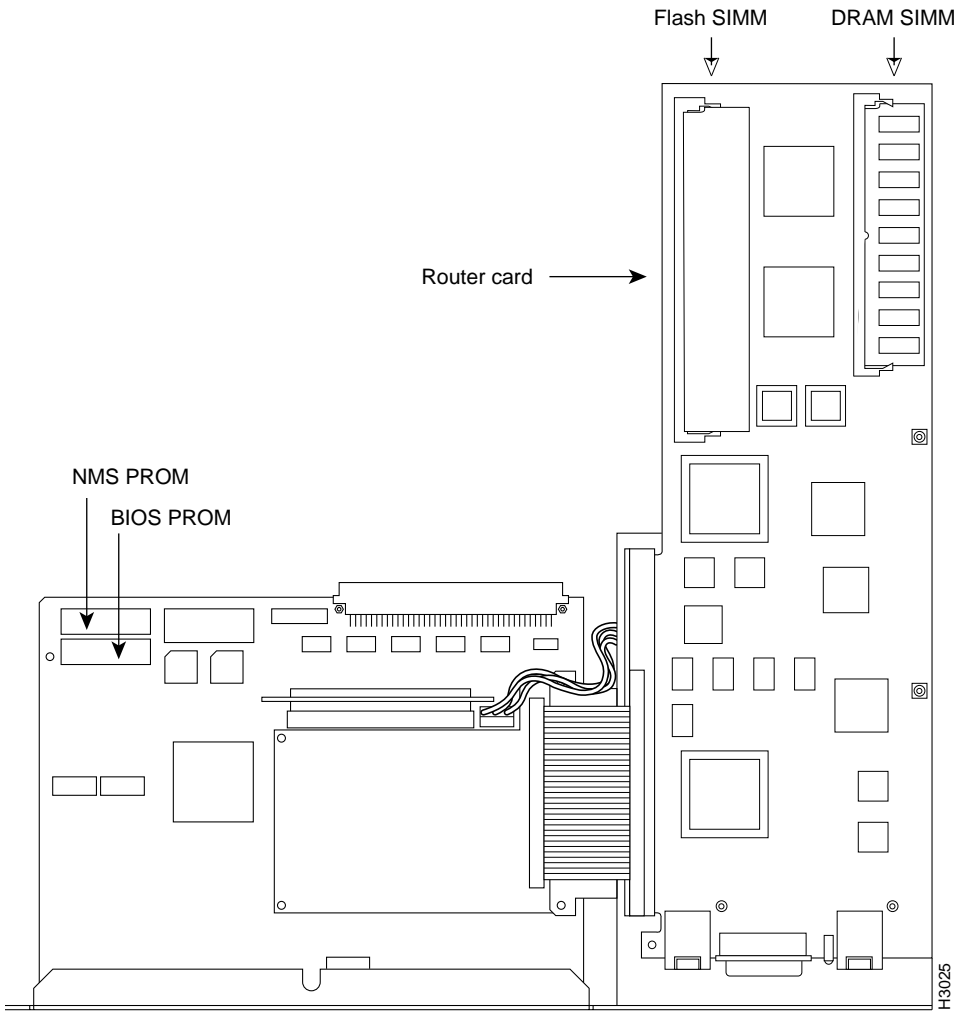

Table 1-5 Management Card LEDs and Reset Button

LED/Button	Description
NMS	Indicates that the management card is active.
IN BAND	When blinking, data is being transmitted or received over in-band communication to the router.
RESET	Push this button to reset the management card and SNMP agent.

Figure 1-6 shows a top view of the management card.

Figure 1-6 Management Card



No jumpers or DIP switches on the management card are user configurable. Remove the management card to replace ROMs or service the router card. See the appendix “Cisco 2517 and Cisco 2519 Router/Hub Maintenance” for management card ROM replacement procedures, or the appendix “Router Card Maintenance” for router card service procedures.

Use the console port on the management card to access the management card’s firmware, as well as the router card software. See the section “Connecting a Terminal or PC to the Router/Hub Console Port” in the chapter “Installing the Router/Hub” for more information.

You can also configure the port for a SLIP or PPP connection to a PC running the Cisco Hub/Ring Manager. See the chapter “Configuring the Router/Hub SNMP Agent with SPSET” in the *Cisco Hub/Ring Manager for Windows Getting Started Guide* on UniverCD or the printed publication for more information.

Router Card

The router card is a full-featured, multiprotocol router card installed in the chassis’s ISA slots. The router card has the following features:

- Multiprotocol router functions
- 2 MB of primary memory, using dynamic random-access memory (DRAM), expandable to 18 MB via a single in-line memory module (SIMM)
- 4 MB of Flash memory for the Cisco IOS software, expandable to 16 MB
- 32-KB nonvolatile random-access memory (NVRAM) for configuration storage
- Two serial ports for connection to a channel service unit/digital service unit (CSU/DSU) or protocol analyzer
- Data terminal equipment/data communications equipment (DTE/DCE) auxiliary port

The RJ-45 asynchronous auxiliary port on the router is used to connect to a terminal or modem.

Figure 1-7 shows the layout of the router card, and Figure 1-8 shows the router card with a daughter card.

Figure 1-7 Router Card

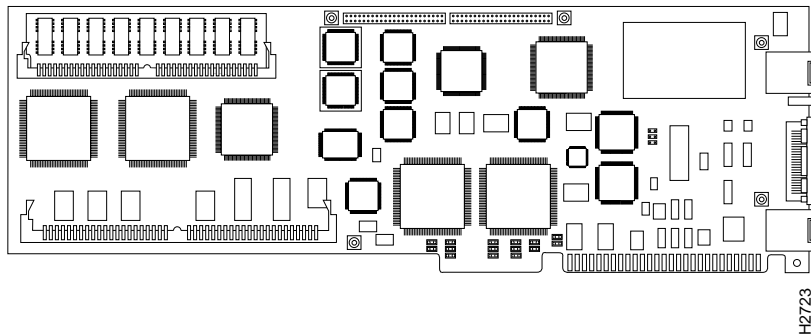
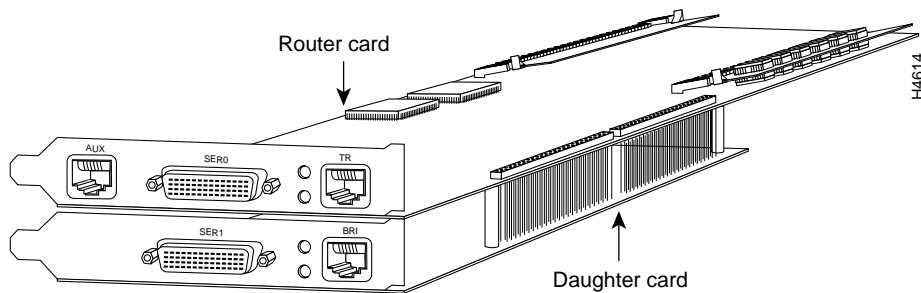

Figure 1-8 Router Card with a Daughter Card



The router card has the following ports:

- RJ-45 Token Ring
- RJ-45 EIA/TIA auxiliary/console
- Two DB-60 synchronous serial
- RJ-45 BRI



Warning Hazardous network voltages are present in the BRI cable. If you detach the BRI cable, detach the end away from the AccessPro card first to avoid possible electric shock. Network hazardous voltages also are present on the system card in the area of the BRI port (RJ-45 connector), regardless of when power is turned off. Translated versions of this warning are in the appendix “Translated Safety Warnings.”

Note EIA/TIA-232 and EIA/TIA-449 were known as recommended standards RS-232 and RS-449 before their acceptance as standards by the Electronics Industry Association (EIA) and Telecommunications Industry Association (TIA).

Figure 1-9 Token Ring Router Card Ports

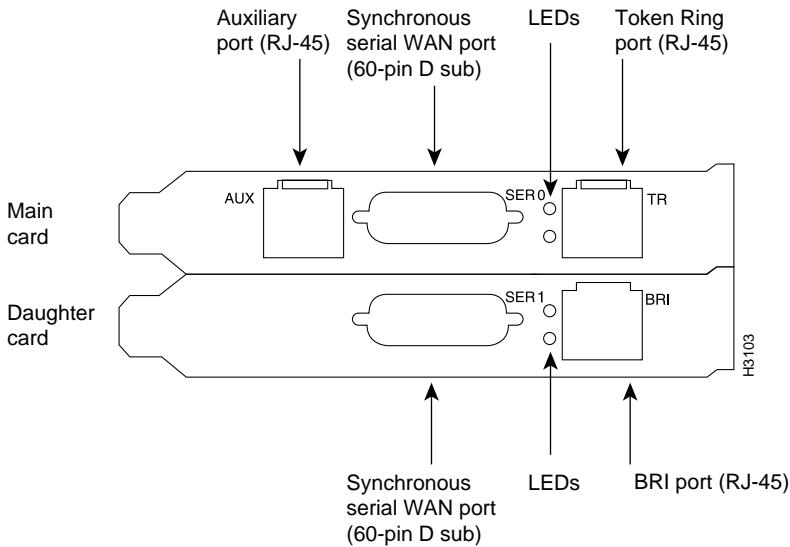

Management Levels

The integrated management software allows you to monitor and control your entire network from a central site.

Physical level management includes port monitor and control for port activity, status, and repeater ports. MAC layer management includes the following features:

- Ring error monitor and configuration report server functions.
- Log events or historical log events functions to retrieve asynchronous events from a remote site without having a direct connection to the SNMP agent.
- Automatic configuration discovery to identify active stations on the ring, and determine their functional parameters.
- Monitor functions allow you to monitor the activity of specified critical devices such as file servers and gateways.
- Security features allow locking of existing configuration and prevent modification by preventing a new station from entering the ring or changing its location.
- The router card is managed with either Cisco IOS commands or the CiscoWorks SNMP manager. The Token Ring hub ports are configured with DIP switches, or managed with Cisco Hub/Ring Manager for Windows.

System Configuration

You configure the router card first by accessing the Cisco IOS software through the management card's console port. The IP address of the router/hub management SNMP agent is assigned automatically with PCbus address resolution protocol (ARP), and is based on the IP address you assigned to the router's PCbus.

See the chapter "Configuring the Router/Hub SNMP Agent with SPSET" for more information.

Specifications

Table 1-6 lists the specifications for the Cisco 2517 and Cisco 2519.

Table 1-6 Cisco 2517 and Cisco 2519 Hub Specifications

Specification	Description
Dimensions (H x L)	3.0 x 19.0" (7.62 x 48.26 cm)
Input voltage and frequency	Cisco 2517: 115/230 VAC, 60/50 Hz Cisco 2519: 100–120/200–240 VAC, 60/50 Hz
Output power	20.0A maximum @ 5V
Power dissipation	100W maximum
Token Ring interfaces	Cisco 2517: 12 IEEE 802.5 (RJ-45) Cisco 2519: 24 IEEE 802.5 (RJ-45)
Serial interfaces	1 EIA/TIA-232
Operating environment	50 to 95°F (10 to 35°C)
Nonoperating temperature	–4 to 185°F (–20 to 85°C)
Operating humidity	5 to 95%, noncondensing
Regulatory Compliance	This product conforms to FCC Class A compliance requirements, and other compliance as outlined in the <i>Cisco 2517 and Cisco 2519 Public Network Certification</i> document that shipped with your order.

Table 1-7 lists the technical specifications for the router card.

Table 1-7 Router Card Specifications

Specification	Description
Dimensions (H x L)	4.8 x 13.3" (12.2 x 33.8 cm)
Power requirements	3.0A @ 5V, 0.5A @ ±12V
Processor	20-MHz Motorola 68EC030
Memory	2-MB primary memory (DRAM SIMMs, expandable to 6 or 18 MB) 4-MB Flash memory (expandable to 16 MB) 32-KB NVRAM
Network interfaces	1 BRI and 2 synchronous serial
Token Ring interface	1 IEEE 802.5 (RJ-45)
Synchronous serial interfaces	EIA/TIA-232, EIA/TIA-449, V.35, X.21 (NRZ/NRZI ¹ and DTE/DCE) EIA-530 (NRZ/NRZI and DTE) All serial cables use a DB-60 chassis connector.
BRI	ISDN basic rate (RJ-45)
Auxiliary/console port	Asynchronous serial (RJ-45, EIA/TIA-232-compatible)
Regulatory Compliance	This product conforms to FCC Class A compliance requirements, and other compliance as outlined in the <i>Cisco 2517 and Cisco 2519 Public Network Certification</i> document that shipped with your order.

1. NRZ = nonreturn to zero; NRZI = nonreturn to zero inverted.

Specifications
