



CHAPTER 1

Modules Overview

This chapter provides important information about the Cisco 7600 series routers modules. This chapter contains these sections:

- [LEDs, page 1-1](#)
- [Port Addresses, page 1-2](#)
- [Hot Swapping Modules, page 1-4](#)
- [Power Management and Environmental Monitoring, page 1-4](#)
- [Limiting Connection Distances, page 1-4](#)
- [Port Densities, page 1-6](#)
- [Gigabit Interface Converters, page 1-7](#)
- [Software Requirements, page 1-13](#)

This book does not contain instructions for installing the router chassis or for installing modules in the router chassis. For information on installing the router chassis, refer to the *Cisco 7600 Series Router Installation Guide*. For information on installing modules in a router chassis, refer to the *Cisco 7600 Series Router Module Installation Guide*.

LEDs

The LEDs on the router module front panel indicate the status of the module. [Table 1-1](#) lists the LEDs and their function.

Table 1-1 Router Module LEDs

LED	Color/State	Description
STATUS	Green	All diagnostics pass. The module is operational (normal initialization sequence).
	Orange	The module is booting or running diagnostics (normal initialization sequence). Make sure the module is fully seated in its slot and that the ejector levers are completely closed.
		An overtemperature condition has occurred. (A minor temperature threshold has been exceeded during environmental monitoring.)

Table 1-1 Router Module LEDs (continued)

LED	Color/State	Description
	Red	The diagnostic test failed. The module is not operational because a fault occurred during the initialization sequence. An overtemperature condition has occurred. (A major temperature threshold has been exceeded during environmental monitoring.)
LINK	Green	The port is operational.
	Orange	The link has been disabled by software.
	Flashing orange	The link is bad and has been disabled due to a hardware failure.
	Off	No signal is detected.

Port Addresses

Each port (or interface) in the router is designated by several different types of addresses. The physical interface address is the actual physical location (slot and port) of the interface connector within the chassis. The system software uses the physical addresses to control activity within the router and to display status information. These physical slot and port addresses are not used by other devices in the network; they are specific to the individual router and its internal components and software. For more information, see the [“Physical Interface Addresses” section on page 1-2](#).



Note

For Cisco 7600 series routers running Cisco IOS software, refer to the appropriate *Cisco 7600 Series Cisco IOS Software Configuration Guide*, for port address information.

The Media Access Control (MAC) address is a standardized data link layer address that is required for every port or device that connects to a network. Other devices in the network use these addresses to locate specific ports in the network and to create and update routing tables and data structures. The routers use a unique method, described in the [“MAC Addresses” section on page 1-3](#), to assign and control the MAC addresses of their interfaces.

Physical Interface Addresses

Physical port addresses specify the actual physical location of each module port on the rear of the router, as shown in [Figure 1-1](#). (The port numbering convention is the same in the 6-slot, 9-slot, and 13-slot chassis.) The address is a two-part number in the format *slot/port number*. The first number identifies the slot in which the module is installed. Module slots are numbered from top to bottom starting with 1. The second number identifies the physical port number on the module. The port numbers always begin at 1 and are numbered from left to right. The number of additional ports (*n/1*, *n/2*, and so on) depends on the number of ports on the module.

Figure 1-1 Slot Numbers on Cisco 7609 Router

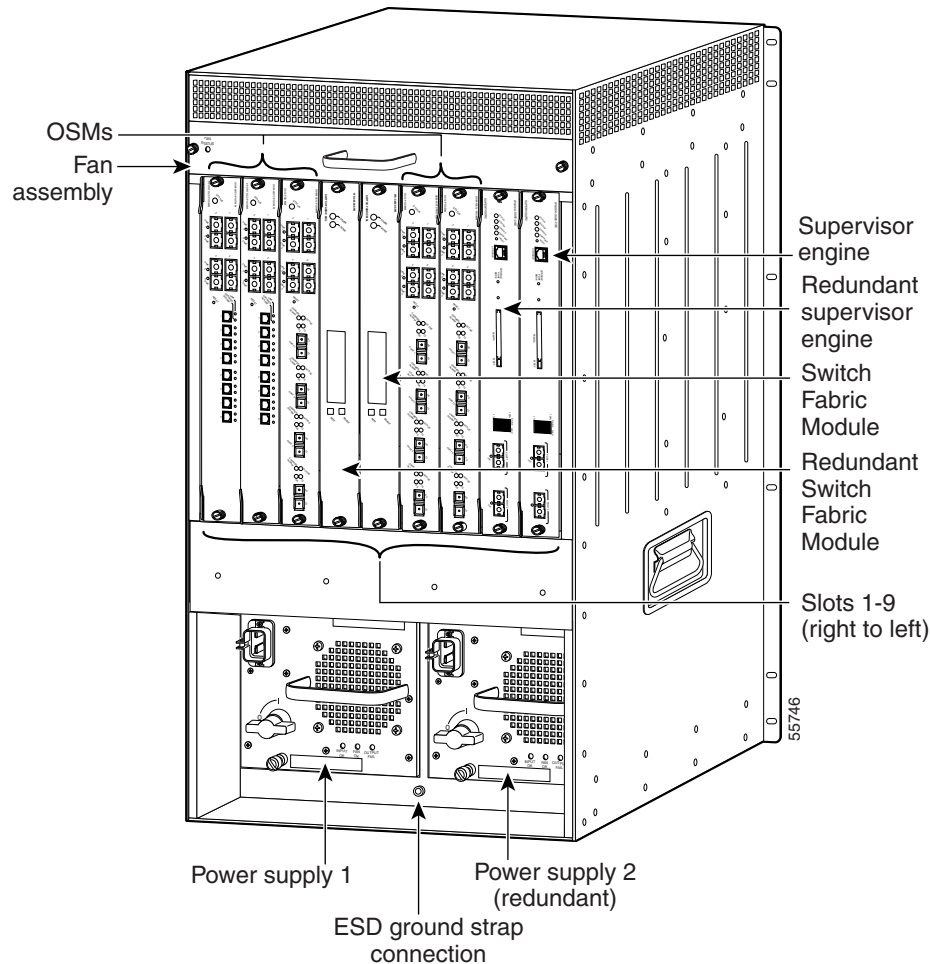

Interface ports maintain the same addresses regardless of whether other modules are installed or removed. However, when you move a module to a different slot, the first number in the address changes to reflect the new slot number. For example, on a 48-port 10/100BASE-T module in slot 2, the address of the left port is 2/1 and the address of the right port is 2/48. If you remove the 48-port 10/100BASE-T module from slot 2 and install it in slot 4, the addresses of those same ports become 4/1 through 4/48.

The supervisor engine is $n/1$ to $n/2$ because it supports two interfaces: ports 1 and 2. Router modules are addressed $n/1$ through n/N .

You can identify each module port by checking its slot and port location on the router. You can also use software commands to display information about a specific interface, or all interfaces, in the router. To display information about every interface, enter the **show port** command without parameters. To display information about a specific interface, enter the **show port** command with the module (slot) number and port number in the format **show port [mod_num/port_num]**.

MAC Addresses

All network interface connections (ports) require a unique MAC address. The MAC address of an interface is stored in electrically erasable programmable read-only memory (EEPROM) on a component that resides directly on the interface circuitry. The router system code reads the EEPROM for each

interface in the system, learns the MAC addresses, and then initializes appropriate hardware and data structures. Each VLAN in the spanning tree has one unique MAC address. This addressing scheme gives the router the intelligence to identify the state (*connected* or *not connected*) of each interface. When you hot swap a module, the MAC address changes with the module.

Hot Swapping Modules

You can remove and replace modules without powering down the router. This feature is known as *hot swapping*.

When you remove or insert a module while the router is powered on and operating, the router does the following:

1. Determines if there is sufficient power for the module.
2. Scans the backplane for configuration changes.
3. Initializes all newly inserted modules, notes any removed modules, and places them in the administratively shutdown state.
4. Places any previously configured interfaces on the module back to the state they were in when they were removed. Any newly inserted interfaces are put in the administratively shutdown state, as if they were present (but unconfigured) at boot time. If you insert a similar module type into a slot, its ports are configured and brought online up to the port count of the original module.

The router runs diagnostic tests on any new interfaces. If the test passes, the router is operating normally. If the new module is faulty, the router resumes normal operation but leaves the new interface disabled.

If the diagnostic test fails, the router crashes, which usually indicates that the new module has a problem in the bus and should be removed.



Caution

To avoid erroneous failure messages, note the current configuration of all interfaces before you remove or replace another module, and allow at least 15 seconds for the system to reinitialize after a module has been removed or replaced.

For router module removal and installation procedures, refer to the *Cisco 7600 Series Router Module Installation Guide*.

Power Management and Environmental Monitoring

For detailed information on power management and environmental monitoring, refer to the appropriate *Cisco 7600 Series Cisco IOS Software Configuration Guide* for your software release.

Limiting Connection Distances

The length of your networks and the distances between connections depend on the type of signal, the signal speed, and the transmission media (the type of cabling used to transmit the signals). For example, fiber-optic cable has a greater channel capacity than twisted-pair cabling. The distance and rate limits in this chapter are the IEEE-recommended maximum speeds and distances for signaling. However, if you understand the electrical problems that may arise and can compensate for them, you should get good results with rates and distances greater than those described here, although you do so at your own risk.

Port Connector Requirements

You need these connector types to cable to the module ports:

- SC connectors for GBICs. (See [Figure 1-2](#).)



Note When you plug the SC connector into the GBIC, make sure that both the Tx and Rx fiber-optic cables are fully inserted into the SC connector.



Note If you are using the LX/LH GBIC with MMF, you need to install a patch cord between the GBIC and the MMF cable. Refer to the “Patch Cord” section of the *Cisco 7600 Series Router Module Installation Guide* for details.

- RJ-45 male connectors for the 48-port 10/100BASE-T RJ-45 module. (See [Figure 1-3](#).)
- MT-RJ fiber-optic connectors for the 24-port 100BASE-FX module. (See [Figure 1-4](#).)
- LC connectors for the SFP optical transceivers installed in the Supervisor Engine 720. (See [Figure 1-5](#).)
- RJ-21 telco connectors for the 48-port 10/100BASE-T R J-21 telco module. (See [Figure 1-6](#).)

Figure 1-2 SC Fiber-Optic Cable Connector

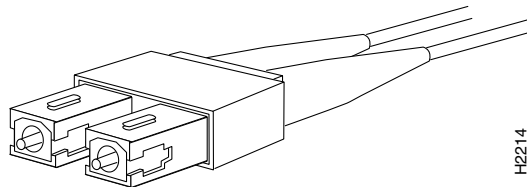

Figure 1-3 RJ-45 Interface Cable Connector

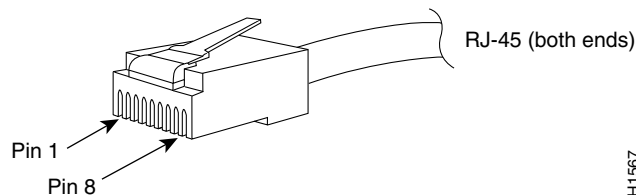
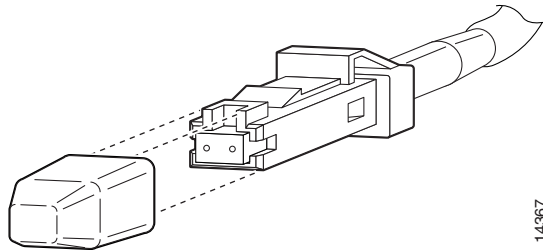
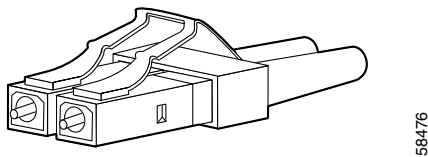
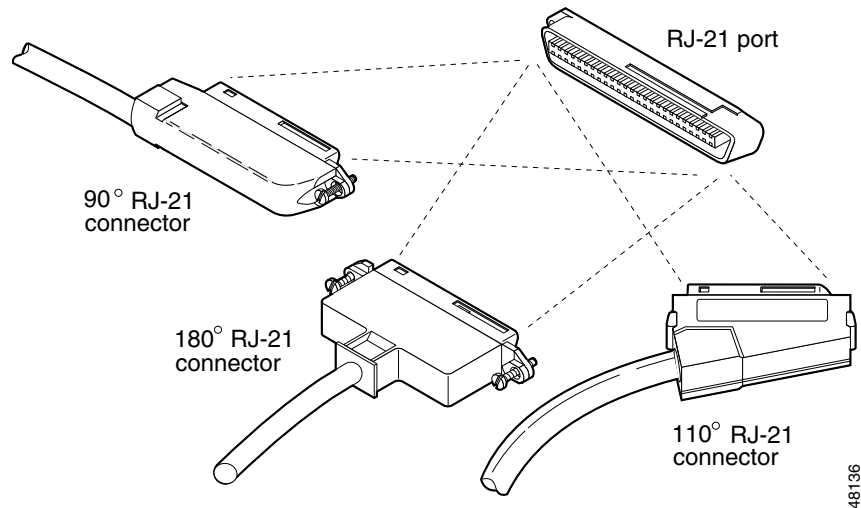

Figure 1-4 MT-RJ Fiber-Optic Cable Connector**Figure 1-5 LC Fiber-Optic Connector****Figure 1-6 RJ-21 Telco Interface Cable Connectors**

Port Densities

Table 1-2 lists the bandwidth and port densities of the Catalyst 6000 series and Catalyst 6500 series routers.

Table 1-2 Cisco 7600 Series Router Bandwidth and Port Density

Architecture	Cisco 7603 Router	Cisco 7604 Router	Cisco 7606 Router	Cisco 7609 Router	Cisco 7609-S Router	Cisco 7613 Router
Backplane Bandwidth for Supervisor Engine 32	32 Gbps	32 Gbps	32 Gbps	32 Gbps	32 Gbps	32 Gbps
Backplane Bandwidth for Supervisor Engine 720	720 Gbps	720 Gbps	720 Gbps	720 Gbps	720 Gbps	720 Gbps
Backplane Bandwidth for Supervisor Engine RSP720	720 Gbps	720 Gbps	720 Gbps	720 Gbps	720 Gbps	720 Gbps
Number of Gigabit Ethernet ports	34	50	82	130	130	194
Number of OC-3 POS ports	32	48	80	128	128	192
Number of OC-12 POS ports	8	12	20	32	32	48
Number of OC-48 POS ports	2	3	5	8	8	12
Number of OC-12 ATM ports	4	6	10	16	16	24
Number of channelized OC-12 ports	8	12	20	32	32	48
Number of FlexWAN modules	2	3	5	8	8	12

Gigabit Interface Converters

A Gigabit Interface Converter (GBIC) is a hot-swappable input/output device that plugs into a supervisor engine or Gigabit Ethernet module which links the module with the fiber-optic network or with the copper network.

This section contains these topics:

- [WS-G5483 Copper GBIC, page 1-8](#)
- [WS-G5484, WS-G5486, and WS-G5487 Optical GBICs, page 1-9](#)
- [Coarse Wave Division Multiplexing GBICs, page 1-9](#)

WS-G5483 Copper GBIC

The WS-G5483 GBIC uses Category 5, Category 5e, or Category 6 UTP/FTP cable to provide 1000BASE-T full-duplex connectivity between the Gigabit Ethernet module or supervisor engine and the network up to a distance of 328 feet (100 meters). (See [Figure 1-7](#).) Refer to your release notes or the online *1000BASE-T GBIC Switch Compatibility Matrix* posted with the GBIC documentation on Cisco.com for the list of modules and the required software release level necessary to support this GBIC.

**Caution**

To comply with GR-1089 intrabuilding, lightning-immunity requirements, you must use foil-twisted pair (FTP) cable that is properly grounded at both ends.

Figure 1-7 Copper GBIC (WS-G5483)

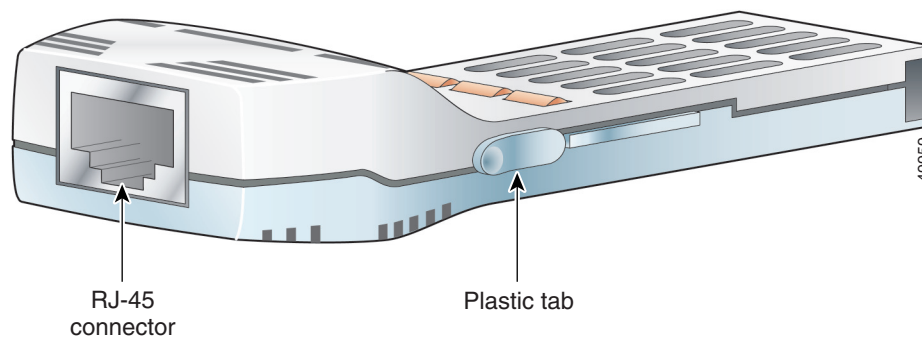

WS-G5484, WS-G5486, and WS-G5487 Optical GBICs

Table 1-3 lists the three types of optical GBICs.

Table 1-3 Optical GBIC Model List

Product Number	GBIC
WS-G5484	Short wavelength (1000BASE-SX)
WS-G5486	Long wavelength/long haul (1000BASE-LX/LH)
WS-G5487	Extended distance (1000BASE-ZX)

Each of the three types of optical GBICs comes in two physical models shown in Figure 1-8. These two physical models require different installation procedures.

Figure 1-8 Optical GBIC Physical Styles (WS-G5484, WS-G5486, and WS-G5487)

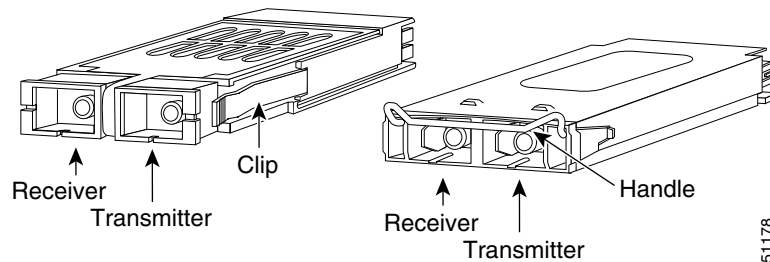

Coarse Wave Division Multiplexing GBICs

Eight GBICs are available for use with the CWDM Passive Optical System. (See Figure 1-9.) Table 1-4 lists the available GBICs. These eight GBICs are installed in the Cisco 7600 series routers modules that support GBICs and are used with the CWDM Passive Optical System. For more information on the CWDM Passive Optical System, refer to the *Installation Note for the Cisco CWDM Passive Optical System*.

Figure 1-9 CWDM GBIC

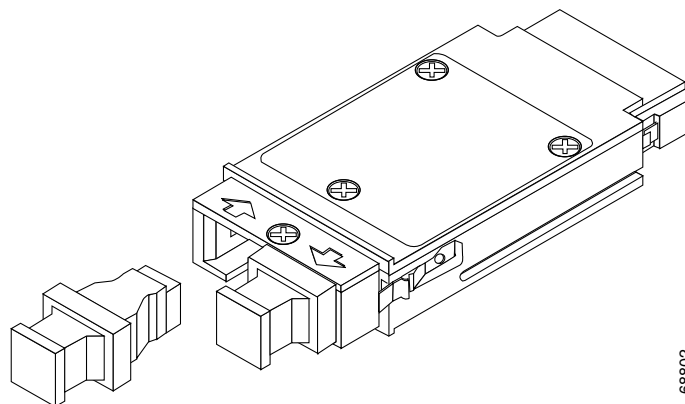

Table 1-4 CWDM GBICs

Model Number	CWDM GBIC Wavelength
CWDM-GBIC-1470=	1470 nm laser, single mode
CWDM-GBIC-1490=	1490 nm laser, single mode
CWDM-GBIC-1510=	1510 nm laser, single mode
CWDM-GBIC-1530=	1530 nm laser, single mode
CWDM-GBIC-1550=	1550 nm laser, single mode
CWDM-GBIC-1570=	1570 nm laser, single mode
CWDM-GBIC-1590=	1590 nm laser, single mode
CWDM-GBIC-1610=	1610 nm laser, single mode

SFP Optical Transceiver Modules

Small Form-Factor Pluggable (SFP) optical transceiver modules are hot-pluggable and field-replaceable, and you can insert them into SFP module slots on the front panel of the Supervisor Engine 720 and the WS-X6724-SFP Gigabit Ethernet module. The SFP optical transceiver modules use an LC connector.

You can use any combination of SFP modules that your Cisco device supports. The only restrictions are that each SFP port must match the wavelength specifications on the other end of the cable and that the cable must not exceed the stipulated cable length for reliable communications.

Figure 1-10 SFP Optical Transceiver Module

Table 1-5 SFP Optical Transceiver Module Cabling Specifications

SFP Module	Wavelength (nanometers)	Fiber Type	Core Size (micron)	Modal Bandwidth (MHz/km)	Cable Distance
1000BASE-SX (GLC-SX-MM)	850	MMF	62.5	160	722 feet (220 m)
			62.5	200	902 feet (275 m)
			50.0	400	1640 feet (500 m)
			50.0	500	1804 feet (550 m)
1000BASE-LX/LH GLC-LH-SM)	1300	MMF ¹	62.5	500	1804 feet (550 m)
			50.0	400	1804 feet (550 m)
		SMF	50.0	500	1804 feet (550 m)
			9/10	—	32,810 feet (10 km)
1000BASE-ZX (GLC-ZX-SM)	1550	SMF	9/10	—	43.4 to 62 miles (70 to 100 km) ²

1. A mode-conditioning patch cord is required. Using an ordinary patch cord with MMF, 1000BASE-LX/LH SFP modules, and a short link distance can cause transceiver saturation, resulting in an elevated bit error rate (BER). When using the LX/LH SFP module with 62.5-micron diameter MMF, you must also install a mode-conditioning patch cord between the SFP module and the MMF cable on both the sending and receiving ends of the link. The mode-conditioning patch cord is required for link distances greater than 984 feet (300 m).
2. 1000BASE-ZX SFP modules can reach up to 100 km by using dispersion-shifted SMF or low-attenuation SMF; the distance depends on the fiber quality, the number of splices, and the connectors.

1000BASE-T SFP Transceiver Modules

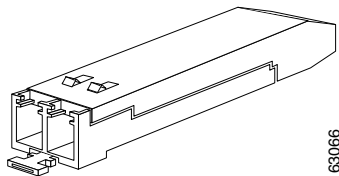
The 1000BASE-T SFP transceiver modules provide Category 5, Category 5e, and Category 6 support for SFP modules. The 1000BASE-T SFP transceiver modules use standard four twisted-pair cable at lengths up to 328 feet (100 meters) and have standard RJ-45 connectors. [Figure 1-11](#) shows a 1000BASE-T SFP module.

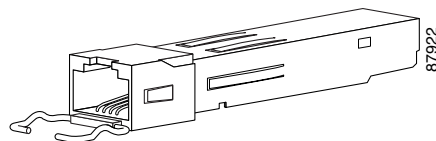
Figure 1-11 1000BASE-T SFP Transceiver Module

CWDM SFP Optical Transceiver Modules

The Coarse Wavelength Division Multiplexing (CWDM) SFP optical transceiver modules are hot-swappable, and can be plugged into standard receptacles in switching modules that convert Gigabit Ethernet electrical signals into a single-mode fiber-optic (SMF) interface. You can connect the CWDM SFPs to CWDM passive optical system optical add/drop multiplexer (OADM) modules or multiplexer/demultiplexer plug-in modules using single-mode fiber-optic cables with standard SC connectors. [Table 1-6](#) lists the available CWDM SFP wavelengths and color-coding identifier.

Table 1-6 CWDM SFP Optical Transceiver Modules

CWDM SFP Product Number	Wavelength	Color
CWDM-SFP-1470	Longwave 1470 nm laser, single mode	Gray
CWDM-SFP-1490	Longwave 1490 nm laser, single mode	Violet
CWDM-SFP-1510	Longwave 1510 nm laser, single mode	Blue
CWDM-SFP-1530	Longwave 1530 nm laser, single mode	Green
CWDM-SFP-1550	Longwave 1550 nm laser, single mode	Yellow
CWDM-SFP-1570	Longwave 1570 nm laser, single mode	Orange
CWDM-SFP-1590	Longwave 1590 nm laser, single mode	Red
CWDM-SFP-1610	Longwave 1610 nm laser, single mode	Brown

Figure 1-12 shows a CWDM SFP with the optical port dust plug removed.

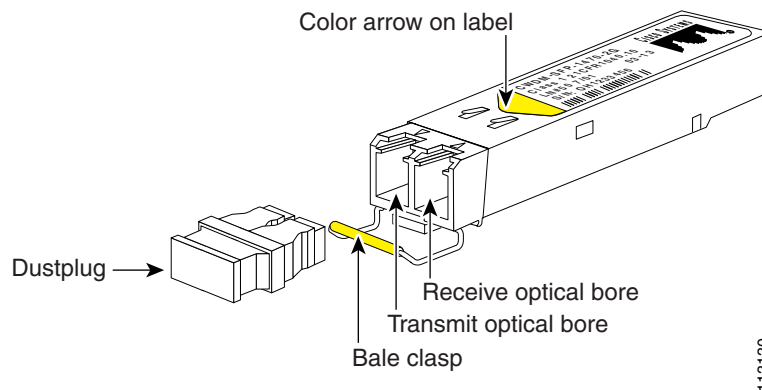
Figure 1-12 CWDM SFP Optical Transceiver Module

XenPak Optical Transceiver Modules

The XenPak optical transceiver modules are hot-swappable, transceiver components that you can plug into standard receptacles in modules that convert Gigabit Ethernet electrical signals into a single-mode fiber-optic (SMF) interface. Figure 1-13 shows a XenPak optical transceiver module.

Figure 1-13 XenPak Optical Transceiver Module

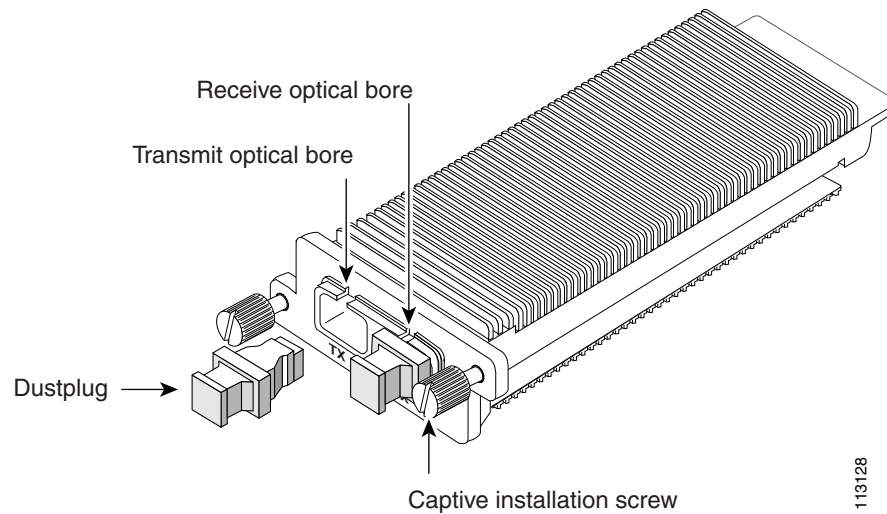

Table 1-7 lists the available XenPak transceiver modules and their specifications.

Table 1-7 XenPak Optical Transceiver Specifications

XenPak	Wavelength	Connector and Cable Type	Maximum Distance
XENPAK-10GB-LR	1310 nm	SC; SMF	6.2 miles (10 km)
XENPAK-10GB-ER	1550 nm	SC; SMF	24.85 miles (40 km)

Software Requirements

For information on the minimum, recommended, and default software versions for the Cisco 7600 series routers, supervisor engines, and modules, refer to the applicable release notes for the latest maintenance release of your software.

