



Installing Cisco ONS 15454 SONET/SDH OPT-BST Cards

Product Names: 15454-OPT-BST

This document provides a card description, specifications, and installation procedure for the dense wavelength division multiplexer (DWDM) OPT-BST card. The OPT-BST card is compatible with Cisco ONS 15454 SONET (ANSI) and Cisco ONS 15454 SDH (ETSI) shelf assemblies. Use this document in conjunction with the *Cisco ONS 15454 DWDM Procedure Guide* when working with OPT-BST cards.

This document contains the following sections:

- [OPT-BST Card Description, page 1](#)
- [OPT-BST Card Specifications, page 5](#)
- [Install the OPT-BST Card, page 6](#)
- [Related Documentation, page 8](#)
- [Obtaining Documentation and Submitting a Service Request, page 8](#)

OPT-BST Card Description

Optical amplifiers are used in amplified nodes such as hub nodes, amplified OADM nodes, and line amplifier nodes. There are two forms of amplifiers, the Optical Pre-amplifier (OPT-PRE) and the Optical Booster (OPT-BST) amplifier. The optical amplifier card architecture includes an optical plug-in module with a controller that manages optical power, laser current, and temperature control loops. The amplifier also manages communication with the TCC2 or TCC2P card and OAM&P functions such as provisioning, controls, and alarms.

Optical amplifiers have a linear power feature that enables them to be kept in the constant gain mode. The OPT-BST gain range is 5 to 20 dB in constant gain mode and output power mode. In constant power mode, automatic power control (APC) requirements change. The change occurs because span loss degradation does not effect the system, and amplifiers cannot automatically modify the output power for variations in the number of channels when a failure occurs.

[Figure 1](#) shows the card faceplate, [Figure 2](#) shows a block diagram of the card, and [Figure 3](#) shows an optical module functional diagram of the OPT-BST card.



Corporate Headquarters:
Cisco Systems, Inc., 170 West Tasman Drive, San Jose, CA 95134-1706 USA

© 2006 Cisco Systems, Inc. All rights reserved.

Figure 1 OPT-BST Faceplate

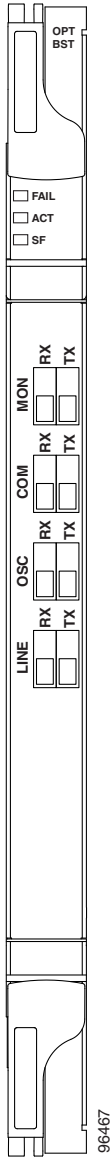

Figure 2 OPT-BST Block Diagram

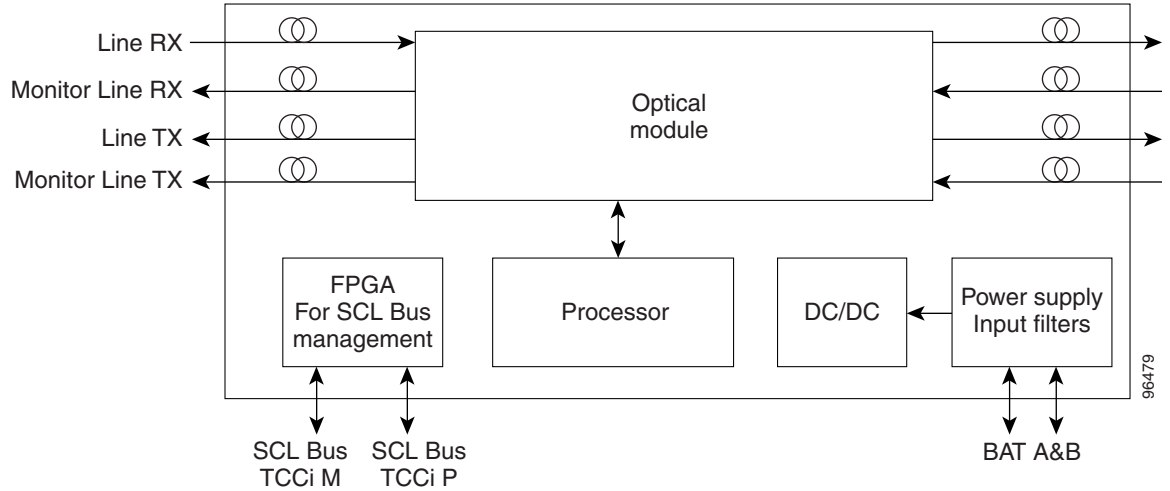
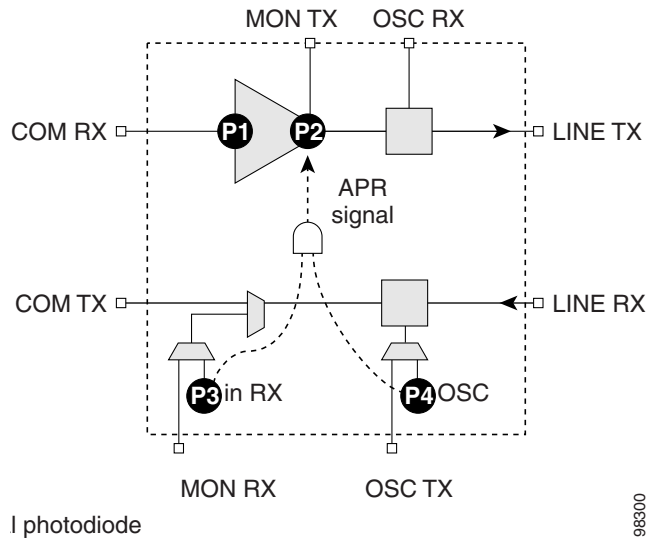

Figure 3 OPT-BST Optical Module Functional Diagram



I photodiode

The OPT-BST card is designed to support 64 channels at 50-GHz channel spacing. The OPT-BST is a C-band DWDM erbium-doped fiber amplifier (EDFA) with optical service channel (OSC) add-and-drop capability. When an ONS 15454 has an OPT-BST installed, only the OPT-BST needs to process the OSC. The OPT-BST card can be installed in Slots 1 to 6 and 12 to 17. To control the gain tilt, the OPT-BST is equipped with a built-in VOA.

The OPT-BST features include:

- Fixed gain mode (with programmable tilt)
- True variable gain
- Fast transient suppression
- Non-distorting low-frequency transfer function
- Provisionable maximum output power
- Fixed output power mode (mode used during provisioning)
- Constant drive current mode (test mode)
- MAL for fiber based DCU
- ASE compensation in fixed gain mode
- Full monitoring and alarm handling with provisionable thresholds
- Optical safety features, including signal loss detection and alarming, fast power down control, and reduced maximum output power in safe power mode
- OSRI, which is a feature capable of shutting down the optical output power or reducing the power to a safe level (automatic power reduction)
- ALS, which is a safety mechanism used in the event of a fiber cut

OPT-BST Card Level Indicators

The OPT-BST card has three card-level LED indicators.

Table 1 OPT-BST Card-Level Indicators

Card-Level Indicators	Description
Red FAIL LED	The red FAIL LED indicates that the card's processor is not ready or that an internal hardware failure has occurred. Replace the card if the red FAIL LED persists.
Green ACT LED	The green ACT LED indicates that the OPT-BST is carrying traffic or is traffic-ready.
Amber SF LED	The amber SF LED indicates a signal failure or condition such as LOS on one or more of the card's ports. The amber SF LED also illuminates when the transmit and receive fibers are incorrectly connected. When the fibers are properly connected, the light turns off.

OPT-BST Port-Level Indicators

You can find the status of the card ports using the LCD screen on the ONS 15454 ANSI fan-tray assembly. Use the LCD to view the status of any port or card slot; the screen displays the number and severity of alarms for a given port or slot.

The OPT-BST amplifier has eight optical ports located on the card faceplate:

- MON Rx is the output monitor port (receive section).
- MON Tx is the output monitor port.

- COM Rx is the input signal port.
- LINE Tx is the output signal port.
- LINE Rx is the input signal port (receive section).
- COM Tx is the output signal port (receive section).
- OSC Rx is the OSC add input port.
- OSC Tx is the OSC drop output port.

OPT-BST Card Specifications

The OPT-BST card has the following specifications:

- Optical characteristics:
 - Total operating wavelength range: 1530 to 1561.3 nm
 - Gain ripple (peak to valley): 1.5 dB
 - Gain range: 5 to 20 dBm with programmable gain tilt
 - Gain and power regulation over/undershoot: 0.5 dB
 - Limited maximum output power: 17.5 dBm
 - Maximum output power (with full channel load): 17 dB
 - Minimum output power (with one channel): -1 dBm
 - Input power (Pin) range at full channel load: -3 to 12 dBm
 - Input power (Pin) range at single channel load: -21 to -6 dBm
 - Noise figure at G3 20 dB = 6 dB
 - OSC filter drop (channels) insertion loss maximum: 1 dB
 - OSC filter drop (OSC) insertion loss maximum: 1.8 dB
 - OSC filter add (OSC) insertion loss maximum: 1.3 dB
 - Optical connectors: LC-UPC/2 Transmitter OSC signal
- Environmental
 - Operating temperature:
 - C-Temp: -5 to +55 degrees Celsius (+23 to +131 degrees Fahrenheit)
 - Operating humidity: 5 to 85%, noncondensing
- Dimensions
 - Height: 12.65 in. (321.3 mm)
 - Width: 0.92 in. (23.4 mm)
 - Depth: 9.00 in. (228.6 mm)
- For compliance information, refer to the *Cisco Optical Transport Products Safety and Compliance Information*.

Install the OPT-BST Card

Warning

During this procedure, wear grounding wrist straps to avoid ESD damage to the card. Do not directly touch the backplane with your hand or any metal tool, or you could shock yourself. Statement 94

Warning

Class 1M laser radiation when open. Do not view directly with optical instruments. Statement 1053

Warning

Invisible laser radiation may be emitted from the end of the unterminated fiber cable or connector. Do not view directly with optical instruments. Viewing the laser output with certain optical instruments (for example, eye loupes, magnifiers, and microscopes) within a distance of 100 mm may pose an eye hazard. Statement 1056

Caution

Always use the supplied ESD wristband when working with a powered ONS 15454. Plug the wristband cable into the ESD jack located on the lower-right outside edge of the shelf assembly.

Caution

Do not install the DWDM cards until you are directed to do so during DWDM node turn up. Refer to the *Cisco ONS 15454 DWDM Procedure Guide* for detailed installation instructions.

Note

If protective clips are installed on the card connectors, remove the clips before installing the cards.

Note

If you install a card incorrectly, the FAIL LED flashes continuously.

Note

When you install a card, the node begins running automatic node setup (ANS) to determine what kind of site you are installing. Amplifier power control (APC) is automatically enabled after ANS initializes and a channel has been provisioned. To provision a DWDM channel, refer to the *Cisco ONS 15454 DWDM Procedure Guide*.

Figure 4 shows general card installation.

Figure 4 Installing an ONS 15454 Card in the ANSI Shelf Assembly

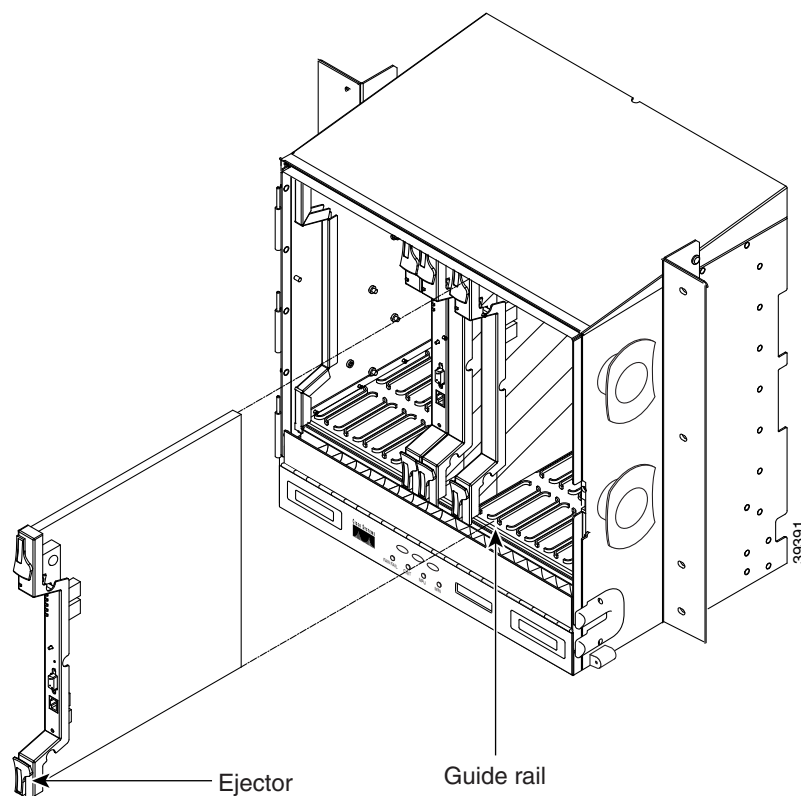

- Step 1** Plan your node installation or consult the site plan. As soon as you begin installing cards, ANS determines what kind of site to set up based on the following parameters:
- Hub site—Two 32DMX-O and two 32MUX-O cards are provisioned but no AD-xC or AD-xB cards are provisioned
 - Terminal—One 32DMX-O and one 32MUX-O card are provisioned, and no AD-xC or AD-xB cards are provisioned
 - Line site—Only one OPT-PRE or OPT-BST is provisioned per line direction. (Up to two OPT-PRE and/or two OPT-BST cards can be provisioned in the same shelf.)
 - OADM site—At least 1 AD-xC or AD-xB is provisioned and no 32DMX-O or 32MUX-O cards are provisioned
 - Unknown—Provisioned cards do not follow any of the previously listed categories.
- Step 2** Open the card latches/ejectors.
- Step 3** Use the latches/ejectors to firmly slide the DWDM card along the guide rails until the card plugs into the receptacle at the back of the slot.
- Step 4** Install the card in any open east and west pair of slots. OPT-BST cards are often installed in Slots 1 and 17.
- Step 5** Verify that the card is inserted correctly and close the latches/ejectors on the card.

**Note**

It is possible to close the latches/ejectors when the card is not completely plugged in. Ensure that you cannot insert the card any further.

Step 6 Verify the following LED activity:

1. The FAIL LED turns on for approximately 35 seconds
2. The FAIL LED blinks for approximately 40 seconds
3. All LEDs turn on and then turn off within 5 seconds
4. If new software is being downloaded to the card, the ACT and SF LEDs blink for 20 seconds to 3.5 minutes, depending on the card type
5. The ACT LED turns on
6. The signal fail (SF) LED stays on until all card ports connect to their far-end counterparts and a signal is present

Step 7 If the card does not boot up properly, or the LED activity does not mimic [Step 6](#), check the following:

- When a physical card type does not match the type of card provisioned for that slot in Cisco Transport Controller (CTC), the card might not boot. In CTC, ensure that the slot is not provisioned for a different card type before assuming the card is faulty.
- If the red FAIL LED does not turn on, check the power.
- If you insert a card into a slot provisioned for a different card, all LEDs turn off.
- If the red FAIL LED is on continuously or the LEDs behave erratically, the card is not installed properly. Remove the card and repeat steps [2](#) to [6](#).

Step 8 Refer to the *Cisco ONS 15454 DWDM Procedure Guide* for provisioning instructions.

Stop. You have completed this procedure.

Related Documentation

- *Cisco ONS 15454 DWDM Reference Manual*
- *Cisco ONS 15454 DWDM Procedure Guide*
- *Cisco ONS 15454 DWDM Troubleshooting Guide*
- *Cisco MetroPlanner DWDM Operations Guide*

Obtaining Documentation and Submitting a Service Request

For information on obtaining documentation, submitting a service request, and gathering additional information, see the monthly *What's New in Cisco Product Documentation*, which also lists all new and revised Cisco technical documentation, at:

<http://www.cisco.com/en/US/docs/general/whatsnew/whatsnew.html>

Subscribe to the *What's New in Cisco Product Documentation* as a Really Simple Syndication (RSS) feed and set content to be delivered directly to your desktop using a reader application. The RSS feeds are a free service and Cisco currently supports RSS Version 2.0.

Use this document in conjunction with the documents listed in the [Related Documentation](#) section.

CCVP, the Cisco logo, and Welcome to the Human Network are trademarks of Cisco Systems, Inc.; Changing the Way We Work, Live, Play, and Learn is a service mark of Cisco Systems, Inc.; and Access Registrar, Aironet, Catalyst, CCDA, CCDP, CCIE, CCIP, CCNA, CCNP, CCSP, Cisco, the Cisco Certified Internetwork Expert logo, Cisco IOS, Cisco Press, Cisco Systems, Cisco Systems Capital, the Cisco Systems logo, Cisco Unity, Enterprise/Solver, EtherChannel, EtherFast, EtherSwitch, Fast Step, Follow Me Browsing, FormShare, GigaDrive, HomeLink, Internet Quotient, IOS, iPhone, IP/TV, iQ Expertise, the iQ logo, iQ Net Readiness Scorecard, iQuick Study, LightStream, Linksys, MeetingPlace, MGX, Networkers, Networking Academy, Network Registrar, PIX, ProConnect, ScriptShare, SMARTnet, StackWise, The Fastest Way to Increase Your Internet Quotient, and TransPath are registered trademarks of Cisco Systems, Inc. and/or its affiliates in the United States and certain other countries.

All other trademarks mentioned in this document or Website are the property of their respective owners. The use of the word partner does not imply a partnership relationship between Cisco and any other company. (0711R)

© 2005 Cisco Systems, Inc. All rights reserved.

 Printed in the USA on recycled paper containing 10% postconsumer waste.



