



# Installing the Cisco ONS 15327 MIC A and MIC B Cards

---

Product Name: 15327-MIC-A-1-T

Product Name: 15327-MIC-B-1-T

This document contains a description of MIC A and MIC B mechanical interface cards features, installation procedures, and technical specifications. Use this document in conjunction with the *Cisco ONS 15327 Reference Manual* and the *Cisco ONS 15327 Procedure Guide* when working with MIC A and MIC B.

This document contains the following sections:

- [“Mechanical Interface Cards” section on page 2](#)
- [“MIC Description” section on page 2](#)
- [“MIC Specifications” section on page 4](#)
- [“Installing the MIC A and the MIC B” section on page 4](#)
- [“Connect Office Power to the ONS 15327 Shelf \(Screw-Lock Power Connector\)” section on page 5](#)
- [“Connect Office Power to the ONS 15327 Shelf \(Terminal-Lug Power Connector\)” section on page 9](#)
- [“Related Documentation” section on page 12](#)
- [“Obtaining Documentation and Submitting a Service Request” section on page 13](#)

This document contains the following procedures:

[“Installing the MIC A and the MIC B” procedure on page 4](#)

[“Connect Office Power to the ONS 15327 Shelf \(Screw-Lock Power Connector\)” procedure on page 5](#)

[“Connect Office Power to the ONS 15327 Shelf \(Terminal-Lug Power Connector\)” procedure on page 9](#)



**Note**

---

For information about circuits and card capacities, see the *Cisco ONS 15327 Reference Manual*.

---

# Mechanical Interface Cards

This section describes the features and functions of the MICs.

## MIC Description

Two MIC cards (MIC A and MIC B) are required to operate the Cisco ONS 15327 if you are using XTC-28-3 cards and/or you need redundant power inputs. The MICs provide power connection points, physical interfaces for DS-1s and DS-3s, and external timing and alarm interfaces.

Figure 1 shows the MIC A faceplate. MIC A is keyed so that it can only be installed in Slot 8.

**Figure 1** MIC A Card Faceplate

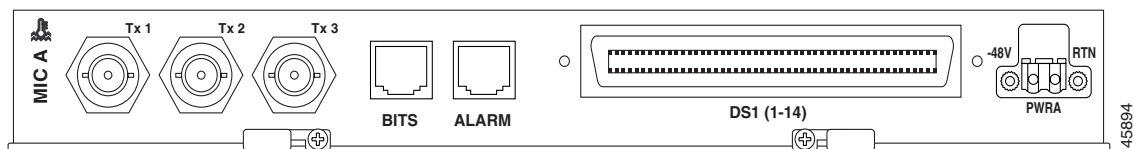
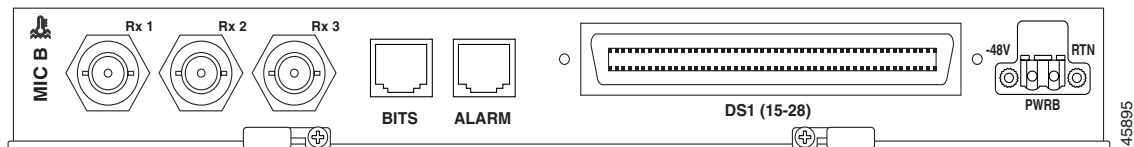

Figure 2 shows the MIC-28-3-B faceplate. MIC-B is keyed so that it can only be installed in Slot 7.

**Figure 2** MIC B Card Faceplate



## DS-1 Physical Interface

Each MIC uses a 64-pin Champ connector to provide 14 DS-1 interfaces. MIC-28-3-A provides connection to DS-1s 1 – 14, and MIC-28-3-B provides connection to DS-1s 15 – 28. The XTC cards house the electrical tributary circuitry for managing the individual DS-1s.

## DS-3 Physical Interface

Because transmit (out) and receive (in) interfaces are on different cards, you must install both MICs to use the DS-3 capabilities of the ONS 15327. The DS-3 interfaces use BNC connectors. MIC-28-3-A provides the three transmit (Tx) interfaces and MIC-28-3-B provides the three receive (Rx) interfaces. The XTC-28-3 card houses the electrical-tributary circuitry for managing DS-3s.

## Power Connection

Each MIC has one -48 VDC power terminal that uses screw lock power connectors (required if you plan to install the right-angle DS-1 cable) or terminal lug power connectors. The National Electrical Code (NEC) requires #12 to #14 AWG wire for the power connection. To establish redundant power, install both MICs and connect each one to a power source.

## External Alarms and Controls

Each MIC has three Form C discrete external alarm inputs and one Form C discrete external control. Connection to the external alarms and controls uses an RJ-45 connector. Two wires of the RJ-45 connector are used for the external control, which defaults to the open position. Six wires of the RJ-45 connector are used for the external alarm input (for additional information, refer to the *Cisco ONS 15327 Procedure Guide*).

In CTC you can provision the six external alarm inputs (three on each MIC) and the two external controls (one on each MIC). External alarm inputs are typically used for external sensors such as open doors, temperature sensors, flood sensors, and other environmental conditions. They can be set to Alarm on Closure or Alarm on Open. The alarm severity can be set to any of the levels (Critical, Major, Minor, Not Alarmed, Not Reported). In addition to severity, you can set alarm type and virtual wire for alarm contacts 1 – 4 and define when the alarm is raised. You can assign a 63-character alarm description for display in the alarm log of the CTC. The alarm condition remains until the external input quits driving the contact and you clear the alarm in the CTC. For instructions, refer to the *Cisco ONS 15327 Procedure Guide*.

External controls are typically used to drive visual or audible devices such as bells and lights, but they can control other devices such as generators, heaters, and fans. You can set them to close when the specified alarm condition is triggered; the default condition for output alarms is the open position. The alarm triggering conditions can be any ONS 15327 alarm condition including the user-defined input alarms, severity-based (e.g. trigger when any Major alarm happens) alarms, or remote alarms. CTC provisioning of this alarm-to-output-contact association is menu driven and includes alarms and individual alarms within categories. The output contact electrical interface is 50 V 100, mA. For procedures that provision external controls, refer to the *Cisco ONS 15327 Procedure Guide*.

**Figure 3 Alarm Pinout for the RJ-45 Port on the Mechanical Interface Card**

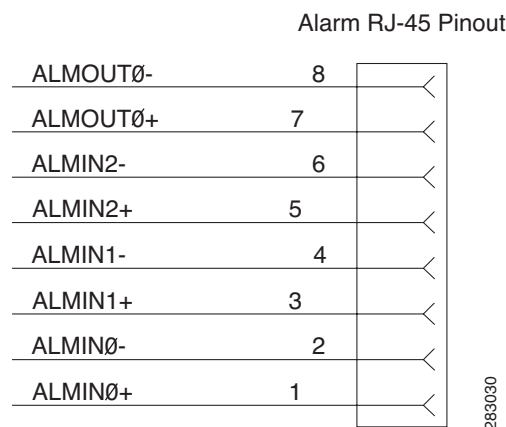

## BITS Interface

Each MIC provides connection for one BITS clock input and one BITS clock output using an RJ-45 connector. Both use two wires of the RJ-45 connector.

## MIC Specifications

- Environmental
  - Operating Temperature: -40 to +149 degrees Fahrenheit (-40 to +65 degrees Celsius)
  - Operating Humidity: 5 to 95%, non-condensing
  - Power Consumption: 4.8 W, 0.1 A, 16.4 BTU/hr
- Dimensions
  - Height: 1.080 in. (27.4 mm)
  - Width: 9.375 in. (238.1 mm)
  - Depth: 9.172 in. (233.0 mm)

## Installing the MIC A and the MIC B



### Warning

**During this procedure, wear grounding wrist straps to avoid ESD damage to the card. Do not directly touch the backplane with your hand or any metal tool to avoid the risk of shock.**

Install MIC A in Slot 8:

- Step 1** Open the card ejectors.
- Step 2** Slide the card along the guide rails into the slot.
- Step 3** Close the ejectors.
- Step 4** Lock the cards into place by tightening the ejector locking screws.

The slots are keyed to ensure that cards are installed in the correct slot. [Figure 4](#) shows the location and corresponding number of each slot.

**Figure 4** ONS 15327 Slot Numbering

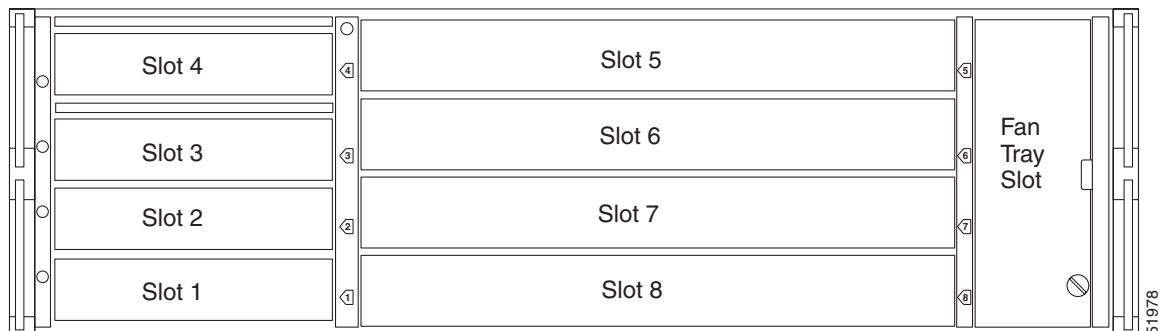

If you require redundant power, more than 14 DS-1s, or you are using DS-3s, install MIC B in Slot 7.



### Warning

**Always make sure power is disconnected before removing MICs from the ONS 15327.**

# Connect Office Power to the ONS 15327 Shelf (Screw-Lock Power Connector)

**Note**

This procedure explains how to install the screw-lock power connector. To install the terminal-lug power connector also included with the ONS 15327, see the [“Connect Office Power to the ONS 15327 Shelf \(Terminal-Lug Power Connector\)” procedure on page 9.](#)

**Note**

You must install this power connector if you plan to install the right-angle DS-1 cable.

**Note**

If you encounter problems with the power supply, refer to the *Cisco ONS 15327 Troubleshooting Guide*.

**Step 1**

Connect the office power according to the fuse panel engineering specifications.

**Step 2**

Measure and cut the cables as needed to reach the ONS 15327 from the fuse panel.

**Step 3**

Dress the power according to local site practice.

**Warning**

**When installing the ONS 15327, the ground connection must always be made first and disconnected last.**

**Step 4**

Strip 0.22 inches of insulation from all power cables that you connect to the ONS 15327 power connectors.

**Warning**

**Do not expose more than 0.22 inches of bare wire on power cables.**

**Step 5**

If the power connector is already installed, remove it from the MIC by grasping it with your fingers and gently pulling it. If you cannot remove it easily, you can use a pair of needle nose pliers and grab it by the center of the channel. [Figure 5](#) shows the MIC power connector being removed.

**Figure 5** Removing the MIC Power Connector

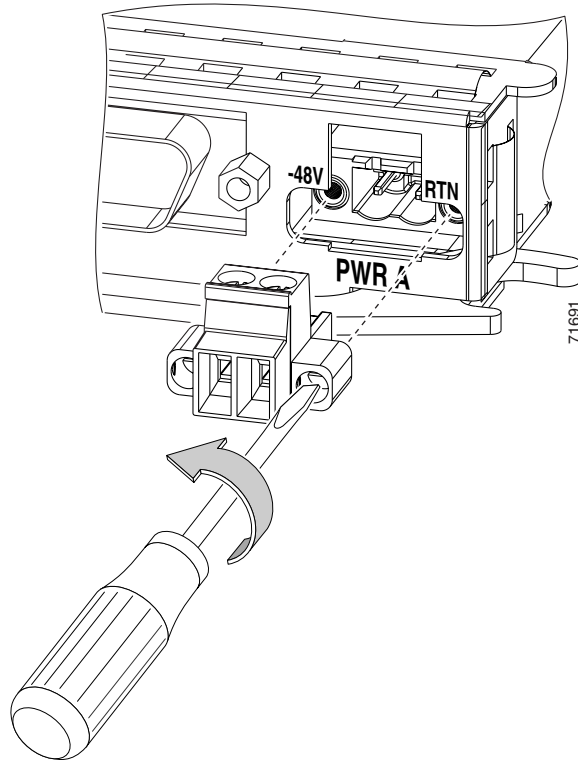

- Step 6** Remove the cable fastening screws, which are the screws on the top of the connector that become visible when the connector is removed.
- Step 7** Insert the (black) return (RTN) wire into the right connector slot. [Figure 6](#) shows a power cable being inserted into the MIC power connector.

**Figure 6** Inserting a Power Cable into the MIC Power Connector

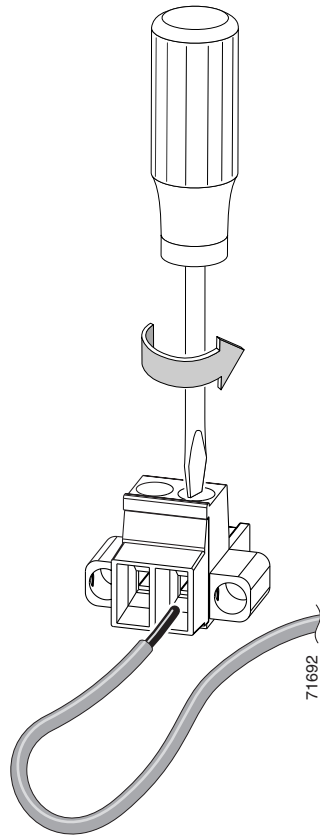

- Step 8** Replace the cable fastening screw for the return (RTN) wire and tighten with a small slot-head screwdriver.
- Step 9** Insert the battery (red) wire into the left (-48V) connector slot.
- Step 10** Replace the cable fastening screw for the battery (-48V) wire and tighten it with the screwdriver.
- Step 11** Insert the connector back into the slot on the MIC and tighten the screws with the screwdriver. [Figure 7](#) shows the MIC power connector being installed.

**Figure 7** Installing the MIC Power Connector

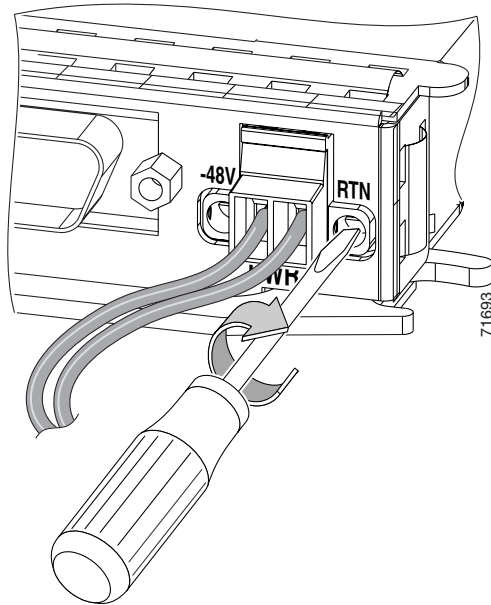

**Step 12** Use a small flat-head screwdriver to open the return (RTN) terminal and insert the return lead.

**Step 13** If you use redundant power feeds, repeat on the other MIC.



**Caution**

In case a power cable is damaged or cut, Cisco recommends that you diversely route redundant power leads along different paths. If you installed the tie-down bar, you can run one power lead across the tie-down bar and secure it using tie-wraps or other site-specific methods. You should route the other power cable in the opposite direction.

Figure 8 shows redundant power connected to an ONS 15327.

**Figure 8** Redundant Power Connections

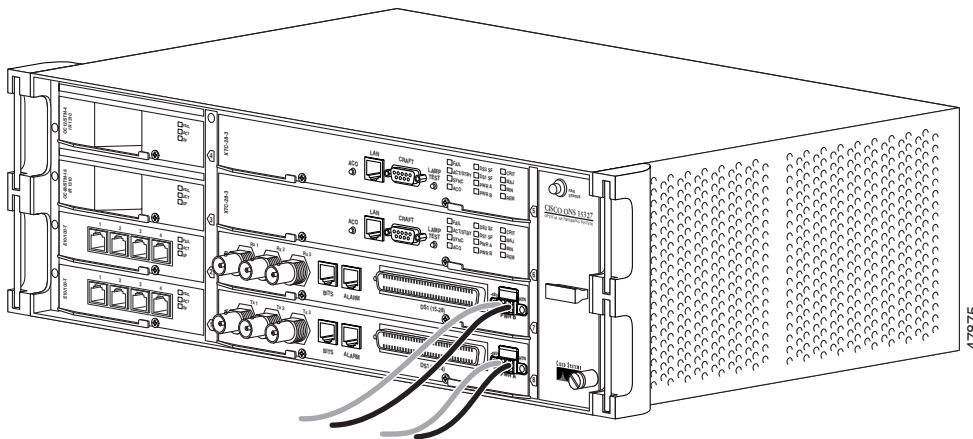

# Connect Office Power to the ONS 15327 Shelf (Terminal-Lug Power Connector)

**Note**

This procedure describes the installation of the terminal-lug power connector. To install the screw-lock power connector also included with the ONS 15327, see the [“Connect Office Power to the ONS 15327 Shelf \(Screw-Lock Power Connector\)” procedure on page 5](#).

**Note**

If you encounter problems with the power supply, refer to the *Cisco ONS 15327 Troubleshooting Guide*.

**Warning**

**Do not apply power to the ONS 15327 until you complete all installation steps and check the continuity of the -48 VDC and return.**

**Step 1**

Connect the office power according to the fuse panel engineering specifications.

**Step 2**

Use 14 AWG, stranded copper conductors. Measure and cut the conductors as needed to reach the ONS 15327 from the fuse panel.

**Step 3**

Dress the power according to local site practice.

**Warning**

**When installing or replacing the unit, the ground connection must always be made first and disconnected last.** Statement 1046

**Step 4**

Strip 0.22 inches (5.59 mm) of insulation from all power conductors that you connect to the ONS 15327 power connectors.

**Warning**

**Do not expose more than 0.22 inches (5.59 mm) of bare wire on power conductors.**

**Caution**

Before you make any crimp connections, coat all bare conductors (battery, battery return, and frame ground) with an appropriate antioxidant compound. Bring all unplated connectors, braided strap, and bus bars to a bright finish, then coat with an antioxidant before you connect them. You do not need to prepare tinned, solder-plated, or silver-plated connectors and other plated connection surfaces in this manner, but always keep them clean and free of contaminants.

**Step 5**

Insert the stripped wire into the terminal until a minimum of 1/32 inch of the conductor extends beyond the barrel.

**Step 6**

Using the Panduit CT-100 crimping tool ([Figure 9](#)), place the terminal onto the red die crimp pocket. Position the crimp pocket on the center of the metal barrel.

**Figure 9 Crimp Pocket Orientation**

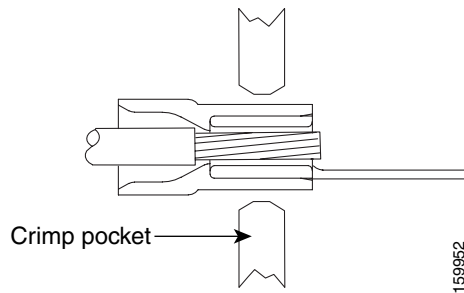

- Step 7** Firmly squeeze the handles of the crimping tool.
- Step 8** Release the handles of the crimping tool and carefully remove the crimped terminal.
- Step 9** If the power connector is already installed, remove it from the MIC by grasping it with your fingers and gently pulling it. If you cannot remove it easily, you can use a pair of needle nose pliers and grab it by the center of the channel.
- Step 10** Remove the terminal lug screws and discard.
- Step 11** Insert the return (black) power conductor in the right hand (RET) slot of the connector. Each lug should be positioned so that the flat portion of the lug faces outwards. See [Figure 10](#) for correct lug orientation.



**Warning**

**Make sure the flat part of the lug faces away from the center of the connector.**

**Figure 10 MIC Terminal Lug Connector**

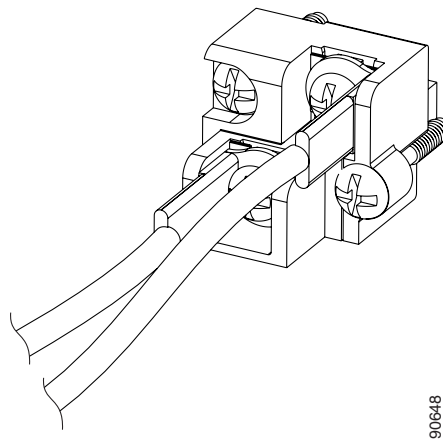

- Step 12** Secure the lug using the screws provided.
- Step 13** Insert the battery (red) wire into the left hand (-48V) slot of the connector. Each lug should be positioned so that the flat portion of the lug faces outwards. See [Figure 10](#) for correct lug orientation



**Warning**

**Make sure the flat part of the lug faces away from the center of the connector.**

- Step 14** Secure the battery (-48V) wire using the screws provided.

- Step 15** Place the plastic shroud over the power connector and plug the power connector into the MIC.
- Step 16** Secure the connector to the shelf using the top left and bottom right screws.

Figure 11 shows power cables connected to the terminal-lug power connector on the MIC.

**Figure 11** Inserting a Power Cable into the MIC Terminal-Lug Power Connector

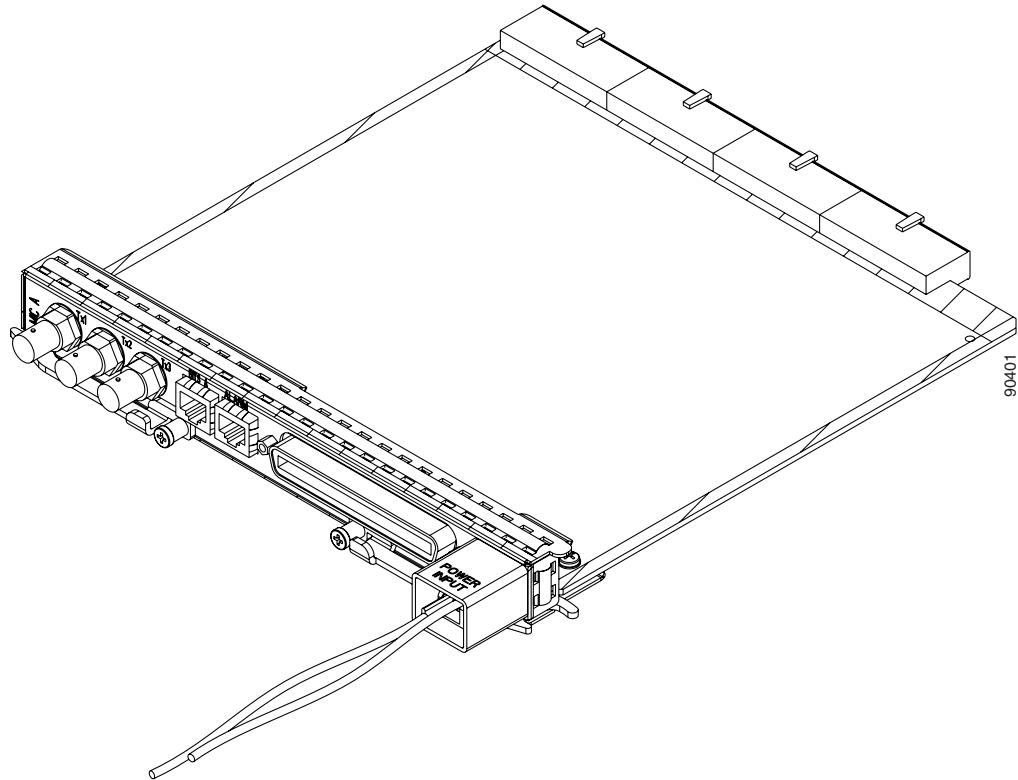

- Step 17** If you use redundant power leads, repeat [Step 16](#) for the other MIC.



**Caution**

In case a power cable is damaged or cut, Cisco recommends that you diversely route redundant power leads along different paths. If you installed the tie-down bar, you can run one power lead across the tie-down bar and secure it using tie-wraps or other site-specific methods. You should route the other power cable in the opposite direction.

Figure 12 shows redundant power connected to an ONS 15327.

**Figure 12** Redundant Power Connected to an ONS 15327

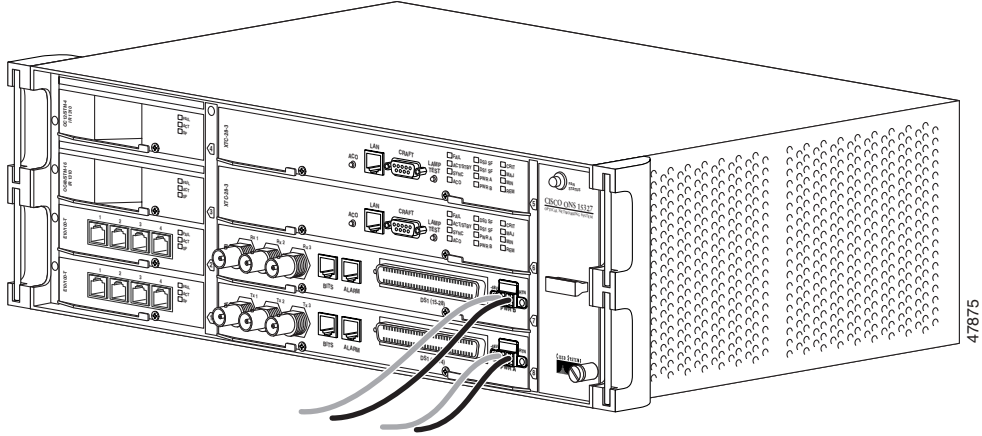

## Related Documentation

- DOC-7815251= *Cisco ONS 15327 Reference Manual*
- DOC-7815250= *Cisco ONS 15327 Procedure Guide*

# Obtaining Documentation and Submitting a Service Request

For information on obtaining documentation, submitting a service request, and gathering additional information, see the monthly *What's New in Cisco Product Documentation*, which also lists all new and revised Cisco technical documentation, at:

<http://www.cisco.com/en/US/docs/general/whatsnew/whatsnew.html>

Subscribe to the *What's New in Cisco Product Documentation* as a Really Simple Syndication (RSS) feed and set content to be delivered directly to your desktop using a reader application. The RSS feeds are a free service and Cisco currently supports RSS version 2.0.

---

This document is to be used in conjunction with the documents listed in the “[Related Documentation](#)” section.

CCVP, the Cisco logo, and Welcome to the Human Network are trademarks of Cisco Systems, Inc.; Changing the Way We Work, Live, Play, and Learn is a service mark of Cisco Systems, Inc.; and Access Registrar, Aironet, Catalyst, CCDA, CCDP, CCIE, CCIP, CCNA, CCNP, CCSP, Cisco, the Cisco Certified Internetwork Expert logo, Cisco IOS, Cisco Press, Cisco Systems, Cisco Systems Capital, the Cisco Systems logo, Cisco Unity, Enterprise/Solver, EtherChannel, EtherFast, EtherSwitch, Fast Step, Follow Me Browsing, FormShare, GigaDrive, HomeLink, Internet Quotient, IOS, iPhone, IP/TV, iQ Expertise, the iQ logo, iQ Net Readiness Scorecard, iQuick Study, LightStream, Linksys, MeetingPlace, MGX, Networkers, Networking Academy, Network Registrar, PIX, ProConnect, ScriptShare, SMARTnet, StackWise, The Fastest Way to Increase Your Internet Quotient, and TransPath are registered trademarks of Cisco Systems, Inc. and/or its affiliates in the United States and certain other countries.

All other trademarks mentioned in this document or Website are the property of their respective owners. The use of the word partner does not imply a partnership relationship between Cisco and any other company. (0711R)

Copyright © 2003 Cisco Systems, Inc. All rights reserved.

