



# CHAPTER 9

## Provision Optical Add/Drop Cards

---

This chapter describes optical add/drop cards used in Cisco ONS 15454 dense wavelength division multiplexing (DWDM) networks. For card safety and compliance information, refer to the [Regulatory Compliance and Safety Information for Cisco CPT and Cisco ONS Platforms](#) document.



**Note**

---

The cards described in this chapter are supported on the Cisco ONS 15454, Cisco ONS 15454 M6, Cisco ONS 15454 M2 platforms, unless noted otherwise.

---



**Note**

---

Unless otherwise specified, “ONS 15454” refers to both ANSI and ETSI shelf assemblies.

---

Chapter topics include:

- [9.1 Card Overview, page 9-1](#)
- [9.2 Safety Labels, page 9-9](#)
- [9.3 AD-1C-xx.x Card, page 9-9](#)
- [9.3.4 Related Procedures for AD-1C-xx.x Card](#)
- [9.4 AD-2C-xx.x Card, page 9-12](#)
- [9.4.5 Related Procedures for AD-2C-xx.x Card](#)
- [9.5 AD-4C-xx.x Card, page 9-16](#)
- [9.5.5 Related Procedures for AD-4C-xx.x Card](#)
- [9.6 AD-1B-xx.x Card, page 9-20](#)
- [9.6.4 Related Procedures for AD-1B-xx.x Card](#)
- [9.7 AD-4B-xx.x Card, page 9-23](#)
- [9.7.4 Related Procedures for AD-4B-xx.x Card](#)

## 9.1 Card Overview

The card overview section contains card overview, software compatibility, interface class, and channel allocation information for optical add/drop cards.

**Note**

Each card is marked with a symbol that corresponds to a slot (or slots) on the ONS 15454 shelf assembly. The cards are then installed into slots displaying the same symbols. For a list of slots and symbols, see the “Card Slot Requirements” section in the *Cisco ONS 15454 Hardware Installation Guide*.

Optical add/drop cards are divided into two groups: band optical add/drop multiplexer (OADM) cards and channel OADM cards. Band OADM cards add and drop one or four bands of adjacent channels. The cards in this chapter, including the 4-Band OADM (AD-4B-xx.x) and the 1-Band OADM (AD-1B-xx.x) are utilized only in the C band. Channel OADM cards add and drop one, two, or four adjacent channels; they include the 4-Channel OADM (AD-4C-xx.x), the 2-Channel OADM (AD-2C-xx.x), and the 1-Channel OADM (AD-1C-xx.x).

**Note**

For information about L band add and drop capability, see [Chapter 10, “Provision Reconfigurable Optical Add/Drop Cards.”](#)

## 9.1.1 Card Summary

[Table 9-1](#) lists and summarizes the functions of the optical add/drop cards.

**Table 9-1**      **Optical Add/Drop Cards**

Card	Port Description	For Additional Information
AD-1C-xx.x	The AD-1C-xx.x card has three sets of ports located on the faceplate. It operates in Slots 1 to 6 and 12 to 17.	See the “ <a href="#">9.3 AD-1C-xx.x Card</a> ” section on page 9-9.
AD-2C-xx.x	The AD-2C-xx.x card has four sets of ports located on the faceplate. It operates in Slots 1 to 6 and 12 to 17.	See the “ <a href="#">9.4 AD-2C-xx.x Card</a> ” section on page 9-12.
AD-4C-xx.x	The AD-4C-xx.x card has six sets of ports located on the faceplate. It operates in Slots 1 to 6 and 12 to 17.	See the “ <a href="#">9.5 AD-4C-xx.x Card</a> ” section on page 9-16.
AD-1B-xx.x	The AD-1B-xx.x card has three sets of ports located on the faceplate. It operates in Slots 1 to 6 and 12 to 17.	See the “ <a href="#">9.6 AD-1B-xx.x Card</a> ” section on page 9-20.
AD-4B-xx.x	The AD-4B-xx.x card has six sets of ports located on the faceplate. It operates in Slots 1 to 6 and 12 to 17.	See the “ <a href="#">9.7 AD-4B-xx.x Card</a> ” section on page 9-23.

## 9.1.2 Card Compatibility

[Table 9-2](#) lists the CTC software compatibility for each optical add/drop card.

**Table 9-2 Software Release Compatibility for Optical Add/Drop Cards**

Card Name	R4.5 - R7.2	R8.0	R8.5	R9.0	R9.1	R9.2	R9.2.1	R9.3	R9.4	R9.6.x
AD-1C-xx.x	15454-DWDM	15454-DWDM	15454-DWDM	15454-DWDM	15454-DWDM	15454-M2, 15454-M6, 15454-DWDM	15454-M2, 15454-M6, 15454-DWDM	15454-M2, 15454-M6, 15454-DWDM	15454-M2, 15454-M6, 15454-DWDM	15454-M2, 15454-M6, 15454-DWDM
AD-2C-xx.x	15454-DWDM	15454-DWDM	15454-DWDM	15454-DWDM	15454-DWDM	15454-M2, 15454-M6, 15454-DWDM	15454-M2, 15454-M6, 15454-DWDM	15454-M2, 15454-M6, 15454-DWDM	15454-M2, 15454-M6, 15454-DWDM	15454-M2, 15454-M6, 15454-DWDM
AD-4C-xx.x	15454-DWDM	15454-DWDM	15454-DWDM	15454-DWDM	15454-DWDM	15454-M2, 15454-M6, 15454-DWDM	15454-M2, 15454-M6, 15454-DWDM	15454-M2, 15454-M6, 15454-DWDM	15454-M2, 15454-M6, 15454-DWDM	15454-M2, 15454-M6, 15454-DWDM
AD-1B-xx.x	15454-DWDM	15454-DWDM	15454-DWDM	15454-DWDM	15454-DWDM	15454-DWDM	15454-DWDM	15454-DWDM	15454-DWDM	15454-DWDM
AD-4B-xx.x	15454-DWDM	15454-DWDM	15454-DWDM	15454-DWDM	15454-DWDM	15454-DWDM	15454-DWDM	15454-DWDM	15454-DWDM	15454-DWDM

### 9.1.3 Interface Classes

The AD-1C-xx.x, AD-2C-xx.x, AD-4C-xx.x, AD-1B-xx.x, and AD-4B-xx.x cards have different input and output optical channel signals depending on the interface card where the input signal originates from. The input interface cards have been grouped in classes listed in [Table 9-3](#). The subsequent tables list the optical performances and output power of each interface class.

**Table 9-3 ONS 15454 Card Interfaces Assigned to Input Power Classes**

Input Power Class	Card
A	10-Gbps multirate transponder cards (TXP_MR_10G, TXP_MR_10E, TXP_MR_10E_C, and TXP_MR_10E_L) with forward error correction (FEC) enabled, 10-Gbps muxponder cards (MXP_2.5G_10G, MXP_2.5G_10E, MXP_MR_10DME_C, MXP_MR_10DME_L, MXP_2.5G_10E_C, and MXP_2.5G_10E_L) with FEC enabled, 40-Gbps transponder cards (40E-TXP-C, and 40ME-TXP-C), and 40-Gbps muxponder cards (40G-MXP-C, 40E-MXP-C, and 40ME-MXP-C)
B	10-Gbps multirate transponder card (TXP_MR_10G) without FEC and the 10-Gbps muxponder card (MXP_2.5G_10G, MXP_MR_10DME_C, MXP_MR_10DME_L), 40-Gbps transponder cards (40E-TXP-C, and 40ME-TXP-C), and 40-Gbps muxponder cards (40G-MXP-C, 40E-MXP-C, and 40ME-MXP-C), and ADM-10G cards with FEC disabled
C	OC-192 LR ITU cards (TXP_MR_10E, TXP_MR_10E_C, and TXP_MR_10E_L) without FEC
D	2.5-Gbps multirate transponder card (TXP_MR_2.5G), both protected and unprotected, with FEC enabled
E	OC-48 100-GHz DWDM muxponder card (MXP_MR_2.5G) and 2.5-Gbps multirate transponder card (TXP_MR_2.5G), both protected and unprotected, with FEC disabled and retune, reshape, and regenerate (3R) mode enabled
F	2.5-Gbps multirate transponder card (TXP_MR_2.5G), both protected and unprotected, in regenerate and reshape (2R) mode
G	OC-48 ELR 100 GHz card
H	2/4 port GbE transponder (GBIC WDM 100GHz)
I	TXP_MR_10E, TXP_MR_10E_C, and TXP_MR_10E_L, 40E-TXP-C, and 40ME-TXP-C cards with enhanced FEC (E-FEC) and the MXP_2.5G_10E, MXP_2.5G_10E_C, MXP_2.5G_10E_L, MXP_MR_10DME_C, MXP_MR_10DME_L, 40G-MXP-C, 40E-MXP-C, and 40ME-MXP-C cards with E-FEC enabled

Table 9-4 lists the optical performance parameters for 40-Gbps cards that provide signal input to the optical add/drop cards.

**Table 9-4 40-Gbps Interface Optical Performance**

Parameter	Class A		Class B		Class I	
	Power Limited	OSNR <sup>1</sup> Limited (if appl.)	Power Limited	OSNR Limited (if appl.)	Power Limited	OSNR Limited (if appl.)
Maximum bit rate	40 Gbps		40 Gbps		40 Gbps	
Regeneration	3R		3R		3R	
FEC	Yes		No		Yes (E-FEC)	
Threshold	Optimum		Average		Optimum	
Maximum BER <sup>2</sup>	10 <sup>-15</sup>		10 <sup>-12</sup>		10 <sup>-15</sup>	

**Table 9-4 40-Gbps Interface Optical Performance (continued)**

Parameter	Class A		Class B		Class I	
	Power Limited	OSNR <sup>1</sup> Limited (if appl.)	Power Limited	OSNR Limited (if appl.)	Power Limited	OSNR Limited (if appl.)
OSNR <sup>1</sup> sensitivity	23 dB	9 dB	23 dB	19 dB	20 dB	8 dB
Power sensitivity	-24 dBm	-18 dBm	-21 dBm	-20 dBm	-26 dBm	-18 dBm
Power overload	-8 dBm		-8 dBm		-8 dBm	
Transmitted Power Range <sup>3</sup>						
40-Gbps multirate transponder/40-Gbps FEC transponder (40E-TXP-C, and 40ME-TXP-C)	+2.5 to 3.5 dBm		+2.5 to 3.5 dBm		—	
OC-192 LR ITU	—		—		—	
Dispersion compensation tolerance	+/-800 ps/nm		+/-1,000 ps/nm		+/-800 ps/nm	

1. OSNR = optical signal-to-noise ratio
2. BER = bit error rate
3. These values, decreased by patchcord and connector losses, are also the input power values for the OADM cards.

Table 9-5 lists the optical performance parameters for 40-Gbps cards that provide signal input to the optical add/drop cards.

**Table 9-5 10-Gbps Interface Optical Performance**

Parameter	Class A		Class B		Class C	Class I	
	Power Limited	OSNR <sup>1</sup> Limited (if appl.)	Power Limited	OSNR Limited (if appl.)	OSNR Limited	Power Limited	OSNR Limited (if appl.)
Maximum bit rate	10 Gbps		10 Gbps		10 Gbps	10 Gbps	
Regeneration	3R		3R		3R	3R	
FEC	Yes		No		No	Yes (E-FEC)	
Threshold	Optimum		Average		Average	Optimum	
Maximum BER <sup>2</sup>	10 <sup>-15</sup>		10 <sup>-12</sup>		10 <sup>-12</sup>	10 <sup>-15</sup>	
OSNR <sup>1</sup> sensitivity	23 dB	9 dB	23 dB	19 dB	19 dB	20 dB	8 dB
Power sensitivity	-24 dBm	-18 dBm	-21 dBm	-20 dBm	-22 dBm	-26 dBm	-18 dBm
Power overload	-8 dBm		-8 dBm		-9 dBm	-8 dBm	

**Table 9-5 10-Gbps Interface Optical Performance (continued)**

Parameter	Class A		Class B		Class C	Class I	
	Power Limited	OSNR <sup>1</sup> Limited (if appl.)	Power Limited	OSNR Limited (if appl.)	OSNR Limited	Power Limited	OSNR Limited (if appl.)
Type	Transmitted Power Range <sup>3</sup>						
10-Gbps multirate transponder/10-Gbps FEC transponder (TXP_MR_10G)	+2.5 to 3.5 dBm		+2.5 to 3.5 dBm		—	—	
OC-192 LR ITU	—		—		+3.0 to 6.0 dBm	—	
10-Gbps multirate transponder/10-Gbps FEC transponder (TXP_MR_10E)	+3.0 to 6.0 dBm		+3.0 to 6.0 dBm		—	+3.0 to 6.0 dBm	
Dispersion compensation tolerance	+/-800 ps/nm		+/-1,000 ps/nm		+/-1,000 ps/nm	+/-800 ps/nm	

1. OSNR = optical signal-to-noise ratio

2. BER = bit error rate

3. These values, decreased by patchcord and connector losses, are also the input power values for the OADM cards.

2.5-Gbps cards that provide signal input to the optical add/drop cards have the interface performance parameters listed in [Table 9-6](#).

**Table 9-6 2.5-Gbps Interface Optical Performance**

Parameter	Class D		Class E		Class F	Class G		Class H		Class J
	Power Limited	OSNR Limited (if appl.)	Power Limited	OSNR Limited (if appl.)	OSNR Limited	Power Limited	OSNR Limited (if appl.)	Power Limited	OSNR Limited (if appl.)	Power Limited
Type	Power Limited		Power Limited		OSNR Limited	Power Limited		Power Limited		Power Limited
Maximum bit rate	2.5 Gbps		2.5 Gbps		2.5 Gbps	2.5 Gbps		1.25 Gbps		2.5 Gbps
Regeneration	3R		3R		2R	3R		3R		3R
FEC	Yes		No		No	No		No		No
Threshold	Average		Average		Average	Average		Average		Average
Maximum BER	10 <sup>-15</sup>		10 <sup>-12</sup>		10 <sup>-12</sup>	10 <sup>-12</sup>		10 <sup>-12</sup>		10 <sup>-12</sup>
OSNR sensitivity	14 dB	6 dB	14 dB	10 dB	15 dB	14 dB	11 dB	13 dB	8 dB	12 dB
Power sensitivity	-31 dBm	-25 dBm	-30 dBm	-23 dBm	-24 dBm	-27 dBm	-33 dBm	-28 dBm	-18 dBm	-26 dBm
Power overload	-9 dBm		-9 dBm		-9 dBm	-9 dBm		-7 dBm		-17dBm

Table 9-6 2.5-Gbps Interface Optical Performance (continued)

Parameter	Class D		Class E		Class F	Class G		Class H		Class J
Type	Power Limited	OSNR Limited (if appl.)	Power Limited	OSNR Limited (if appl.)	OSNR Limited	Power Limited	OSNR Limited (if appl.)	Power Limited	OSNR Limited (if appl.)	Power Limited
Transmitted Power Range <sup>1</sup>										
TXP_MR_2.5G	-1.0 to 1.0 dBm		-1.0 to 1.0 dBm		-1.0 to 1.0 dBm	-2.0 to 0 dBm		—		—
TXPP_MR_2.5G	-4.5 to -2.5 dBm		-4.5 to -2.5 dBm		-4.5 to -2.5 dBm					
MXP_MR_2.5G	—		+2.0 to +4.0 dBm		—					
MXPP_MR_2.5G	—		-1.5 to +0.5 dBm		—					
2/4 port GbE Transponder (GBIC WDM 100GHz)	—		—		—	—		+2.5 to 3.5 dBm		—
Dispersion compensation tolerance	-1200 to +5400 ps/nm		-1200 to +5400 ps/nm		-1200 to +3300 ps/nm	-1200 to +3300 ps/nm		-1000 to +3600 ps/nm		-1000 to +3200 ps/nm

1. These values, decreased by patchcord and connector losses, are also the input power values for the OADM cards.

## 9.1.4 DWDM Card Channel Allocation Plan

ONS 15454 DWDM channel OADM and band OADM cards are designed for use with specific channels in the C band. In most cases, the channels for these cards are either numbered (for example, 1 to 32) or delimited (odd or even). Client interfaces must comply with these channel assignments to be compatible with the ONS 15454 system.

Table 9-7 lists the channel IDs and wavelengths assigned to the C-band DWDM channels.



### Note

In some cases, a card uses only some or all of the channels listed in a band. Also, some cards use channels on the 100-GHz ITU-T grid while others use channels on the 50-GHz ITU-T grid. See specific card descriptions in Appendix B, “Hardware Specifications,” for more details.

Table 9-7 DWDM Channel Allocation Plan (C Band)

Channel Number	Frequency (THz)	Wavelength (nm)	Channel Number	Frequency (THz)	Wavelength (nm)
1	196.00	1529.55	42	193.95	1545.72
2	195.95	1529.94	43	193.90	1546.119
3	195.90	1530.334	44	193.85	1546.518
4	195.85	1530.725	45	193.80	1546.917
5	195.80	1531.116	46	193.75	1547.316
6	195.75	1531.507	47	193.70	1547.715

Table 9-7 DWDM Channel Allocation Plan (C Band) (continued)

Channel Number	Frequency (THz)	Wavelength (nm)	Channel Number	Frequency (THz)	Wavelength (nm)
7	195.70	1531.898	48	193.65	1548.115
8	195.65	1532.290	49	193.60	1548.515
9	195.60	1532.681	50	193.55	1548.915
10	195.55	1533.073	51	193.50	1549.32
11	195.50	1533.47	52	193.45	1549.71
12	195.45	1533.86	53	193.40	1550.116
13	195.40	1534.250	54	193.35	1550.517
14	195.35	1534.643	55	193.30	1550.918
15	195.30	1535.036	56	193.25	1551.319
16	195.25	1535.429	57	193.20	1551.721
17	195.20	1535.822	58	193.15	1552.122
18	195.15	1536.216	59	193.10	1552.524
19	195.10	1536.609	60	193.05	1552.926
20	195.05	1537.003	61	193.00	1553.33
21	195.00	1537.40	62	192.95	1553.73
22	194.95	1537.79	63	192.90	1554.134
23	194.90	1538.186	64	192.85	1554.537
24	194.85	1538.581	65	192.80	1554.940
25	194.80	1538.976	66	192.75	1555.343
26	194.75	1539.371	67	192.70	1555.747
27	194.70	1539.766	68	192.65	1556.151
28	194.65	1540.162	69	192.60	1556.555
29	194.60	1540.557	70	192.55	1556.959
30	194.55	1540.953	71	192.50	1557.36
31	194.50	1541.35	72	192.45	1557.77
32	194.45	1541.75	73	192.40	1558.173
33	194.40	1542.142	74	192.35	1558.578
34	194.35	1542.539	75	192.30	1558.983
35	194.30	1542.936	76	192.25	1559.389
36	194.25	1543.333	77	192.20	1559.794
37	194.20	1543.730	78	192.15	1560.200
38	194.15	1544.128	79	192.10	1560.606
39	194.10	1544.526	80	192.05	1561.013
40	194.05	1544.924	81	192.00	1561.42
41	194.00	1545.32	82	191.95	1561.83

## 9.2 Safety Labels

For information about safety labels, see the “[G.1.2 Class 1M Laser Product Cards](#)” section on page G-4.

## 9.3 AD-1C-xx.x Card

**Note**

For AD-1C-xx.x card specifications, see the “[AD-1C-xx.x Card Specifications](#)” section in the Hardware Specifications document.

The 1-Channel OADM (AD-1C-xx.fx) card passively adds or drops one of the 32 channels utilized within the 100-GHz-spacing of the DWDM card system. Thirty-two versions of this card—each designed only for use with one wavelength—are used in the ONS 15454 DWDM system. Each wavelength version of the card has a different part number. The AD-1C-xx.x can be installed in Slots 1 to 6 and 12 to 17.

The AD-1C-xx.x has the following internal features:

- Two cascaded passive optical interferential filters perform the channel add and drop functions.
- One software-controlled variable optical attenuator (VOA) regulates the optical power of the inserted channel.
- Software-controlled VOA regulates the insertion loss of the express optical path.
- VOA settings and functions, photodiode detection, and alarm thresholds, are internally controlled.
- Virtual photodiodes (firmware calculations of port optical power) at the common DWDM output and input ports are monitored within the software.

### 9.3.1 Faceplate and Block Diagrams

[Figure 9-1](#) shows the AD-1C-xx.x faceplate.

Figure 9-1 AD-1C-xx.x Faceplate

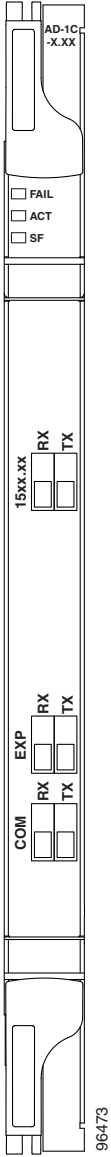

For information on safety labels for the card, see the [“9.2 Safety Labels”](#) section on page 9-9. [Figure 9-2](#) shows a block diagram of the AD-1C-xx.x card.

Figure 9-2 AD-1C-xx.x Block Diagram

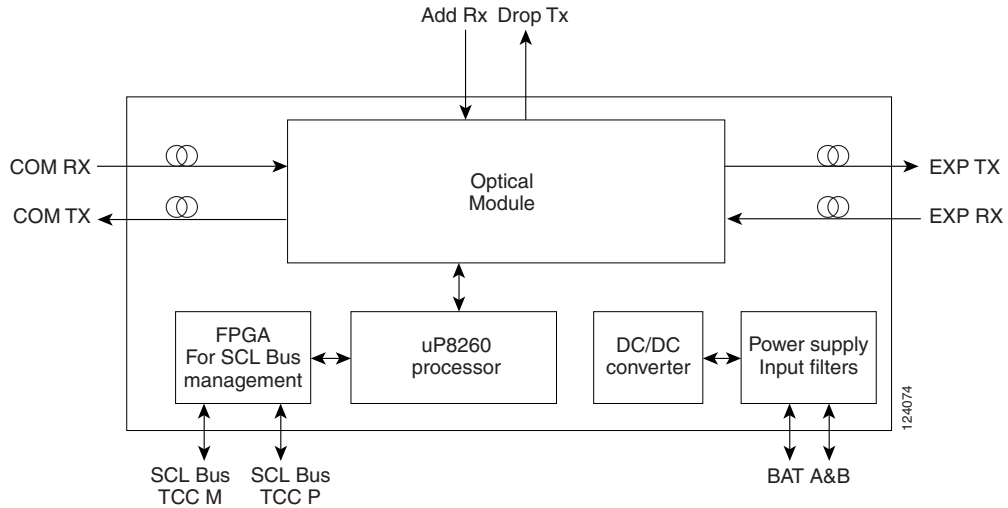
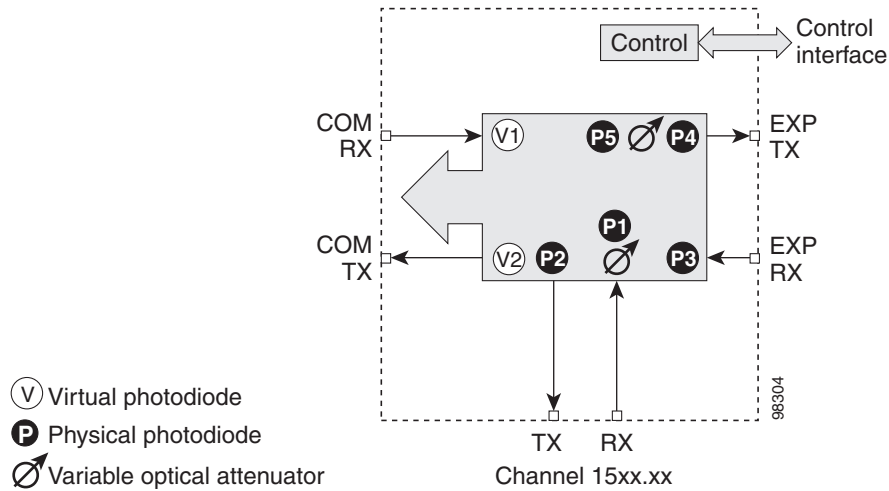

Figure 9-3 shows the AD-1C-xx.x optical module functional block diagram.

Figure 9-3 AD-1C-xx.x Optical Module Functional Block Diagram



## 9.3.2 Power Monitoring

Physical photodiodes P1 through P4 and virtual photodiodes V1 and V2 monitor the power for the AD-1C-xx.x card. The returned power level values are calibrated to the ports as shown in Table 9-8.

Table 9-8 AD-1C-xx.x Port Calibration

Photodiode	CTC Type Name	Calibrated to Port
P1	ADD	DROP RX
P2	DROP	DROP TX

**Table 9-8 AD-1C-xx.x Port Calibration (continued)**

Photodiode	CTC Type Name	Calibrated to Port
P3	IN EXP	EXP RX
P4	OUT EXP	EXP TX
V1	IN COM	COM RX
V2	OUT COM	COM TX

For information on the associated TL1 AIDs for the optical power monitoring points, refer the “CTC Port Numbers and TL1 Aids” section in *Cisco ONS SONET TL1 Command Guide, Release 9.2.1*.

### 9.3.3 AD-1C-xx.x Card Functions

- Card level indicators—[Table G-4 on page G-9](#)
- [“G.4 Port-Level Indicators” section on page G-10](#)

### 9.3.4 Related Procedures for AD-1C-xx.x Card

The following section lists procedures and tasks related to the configuration of the AD-1C-xx.x card:

- [“NTP-G30 Install the DWDM Cards” procedure on page 14-63](#)
- [“NTP-G37 Run Automatic Node Setup” procedure on page 14-124](#)
- [“NTP-G59 Create, Delete, and Manage Optical Channel Network Connections” procedure on page 17-40](#)
- [“NTP-G51 Verify DWDM Node Turn Up” procedure on page 16-2](#)
- [NTP-G74 Monitor DWDM Card Performance](#)
- [“NTP-G106 Reset Cards Using CTC” procedure on page 24-14](#)
- [NTP-G107 Remove Permanently or Remove and Replace DWDM Cards](#)
- [“NTP-G119 Power Down the Node” procedure on page 24-23](#)

## 9.4 AD-2C-xx.x Card



#### Note

For AD-2C-xx.x card specifications, see the [“AD-2C-xx.x Card Specifications”](#) section in the Hardware Specifications document.

The 2-Channel OADM (AD-2C-xx.x) card passively adds or drops two adjacent 100-GHz channels within the same band. Sixteen versions of this card—each designed for use with one pair of wavelengths—are used in the ONS 15454 DWDM system. The card bidirectionally adds and drops in two different sections on the same card to manage signal flow in both directions. Each version of the card has a different part number.

The AD-2C-xx.x has the following features:

- Passive cascade of interferential filters perform the channel add and drop functions.

- Two software-controlled VOAs in the add section, one for each add port, regulate the optical power of inserted channels.
- Software-controlled VOAs regulate insertion loss on express channels.
- VOA settings and functions, photodiode detection, and alarm thresholds are internally controlled.
- Virtual photodiodes (firmware calculation of port optical power) at the common DWDM output and input ports are monitored within the software.

## 9.4.1 Faceplate and Block Diagrams

Figure 9-4 shows the AD-2C-xx.x faceplate.

**Figure 9-4** AD-2C-xx.x Faceplate

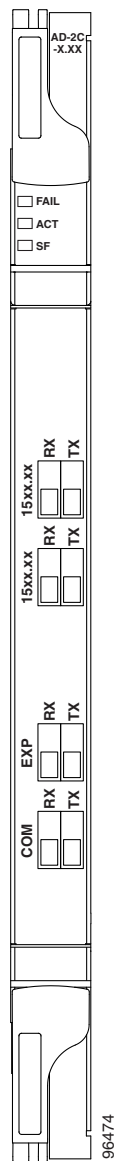

For information on safety labels for the card, see the “9.2 Safety Labels” section on page 9-9. Figure 9-5 shows a block diagram of the AD-2C-xx.x card.

Figure 9-5 AD-2C-xx.x Block Diagram

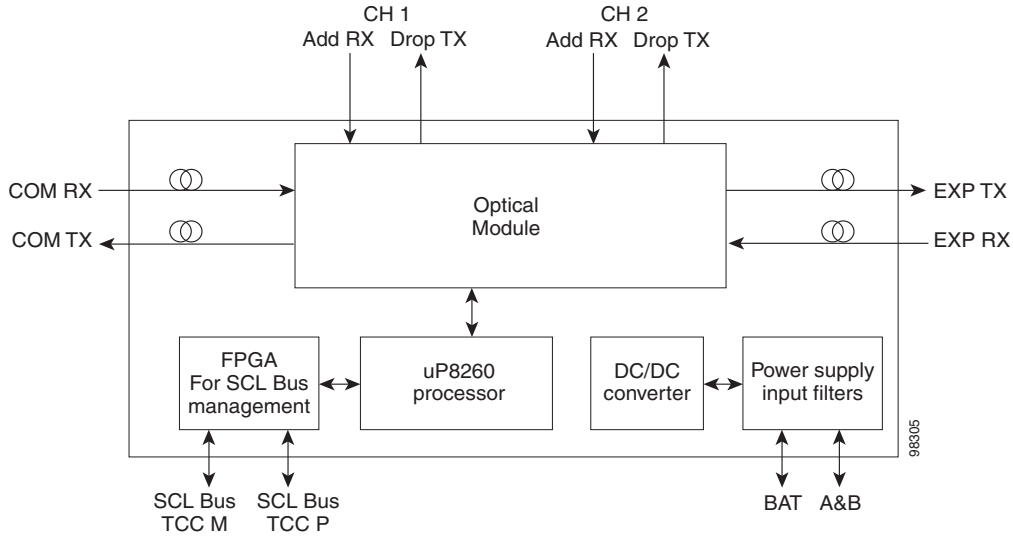
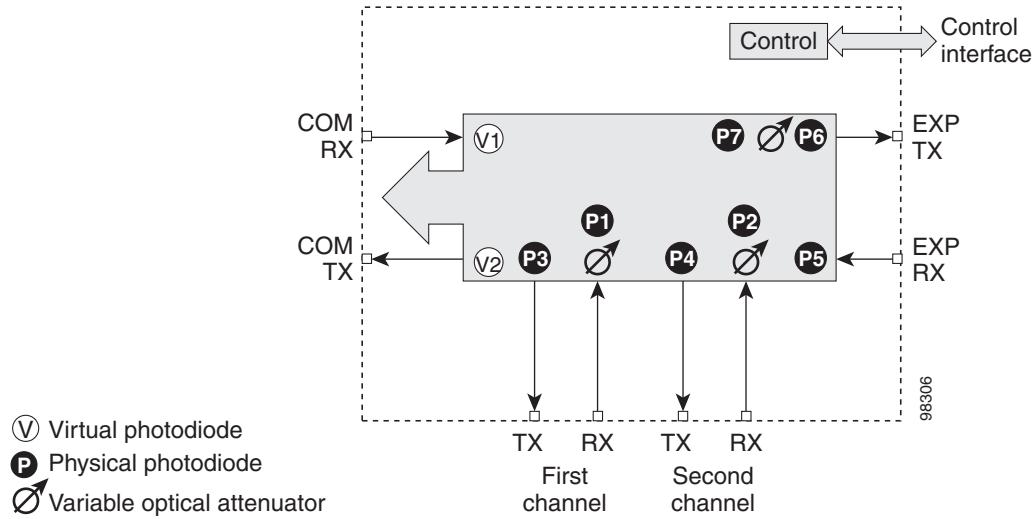

Figure 9-6 shows the AD-2C-xx.x optical module functional block diagram.

Figure 9-6 AD-2C-xx.x Optical Module Functional Block Diagram



## 9.4.2 Wavelength Pairs

The AD-2C-xx.x cards are provisioned for the wavelength pairs listed in Table 9-9. In this table, channel IDs are given rather than wavelengths. To compare channel IDs with the actual wavelengths they represent, see wavelengths in Table 9-7 on page 9-7.

**Table 9-9 AD-2C-xx.x Channel Pairs**

Band ID	Add/Drop Channel ID
Band 30.3 (A)	30.3, 31.2
	31.9, 32.6
Band 34.2 (B)	34.2, 35.0
	35.8, 36.6
Band 38.1 (C)	38.1, 38.9
	39.7, 40.5
Band 42.1 (D)	42.1, 42.9
	43.7, 44.5
Band 46.1 (E)	46.1, 46.9
	47.7, 48.5
Band 50.1 (F)	50.1, 50.9
	51.7, 52.5
Band 54.1 (G)	54.1, 54.9
	55.7, 56.5
Band 58.1 (H)	58.1, 58.9
	59.7, 60.6

## 9.4.3 Power Monitoring

Physical photodiodes P1 through P10 and virtual photodiodes V1 and V2 monitor the power for the AD-2C-xx.x card. The returned power level values are calibrated to the ports as shown in [Table 9-10](#).

**Table 9-10 AD-2C-xx.x Port Calibration**

Photodiode	CTC Type Name	Calibrated to Port
P1–P2	ADD	COM TX
P3–P4	DROP	DROP TX
P5	IN EXP	EXP RX
P6	OUT EXP	EXP TX
V1	IN COM	COM RX
V2	OUT COM	COM TX

For information on the associated TL1 AIDs for the optical power monitoring points, refer the “CTC Port Numbers and TL1 Aids” section in *Cisco ONS SONET TL1 Command Guide, Release 9.2.1*.

## 9.4.4 AD-2C-xx.x Card Functions

- Card level indicators—[Table G-4 on page G-9](#)

- “G.4 Port-Level Indicators” section on page G-10

## 9.4.5 Related Procedures for AD-2C-xx.x Card

The following section lists procedures and tasks related to the configuration of the AD-2C-xx.x card:

- “NTP-G30 Install the DWDM Cards” procedure on page 14-63
- “NTP-G37 Run Automatic Node Setup” procedure on page 14-124
- “NTP-G59 Create, Delete, and Manage Optical Channel Network Connections” procedure on page 17-40
- “NTP-G51 Verify DWDM Node Turn Up” procedure on page 16-2
- NTP-G74 Monitor DWDM Card Performance
- “NTP-G106 Reset Cards Using CTC” procedure on page 24-14
- NTP-G107 Remove Permanently or Remove and Replace DWDM Cards
- “NTP-G119 Power Down the Node” procedure on page 24-23

## 9.5 AD-4C-xx.x Card



### Note

For AD-4C-xx.x card specifications, see the “[AD-4C-xx.x Card Specifications](#)” section in the Hardware Specifications document.

The 4-Channel OADM (AD-4C-xx.x) card passively adds or drops all four 100-GHz-spaced channels within the same band. Eight versions of this card—each designed for use with one band of wavelengths—are used in the ONS 15454 DWDM system. The card bidirectionally adds and drops in two different sections on the same card to manage signal flow in both directions. There are eight versions of this card with eight part numbers.

The AD-4C-xx.x has the following features:

- Passive cascade of interferential filters perform the channel add and drop functions.
- Four software-controlled VOAs in the add section, one for each add port, regulate the optical power of inserted channels.
- Two software-controlled VOAs regulate insertion loss on express and drop path, respectively.
- Internal control of the VOA settings and functions, photodiode detection, and alarm thresholds.
- Software-monitored virtual photodiodes (firmware calculation of port optical power) at the common DWDM output and input ports.

### 9.5.1 Faceplate and Block Diagrams

Figure 9-7 shows the AD-4C-xx.x faceplate.

**Figure 9-7 AD-4C-xx.x Faceplate**

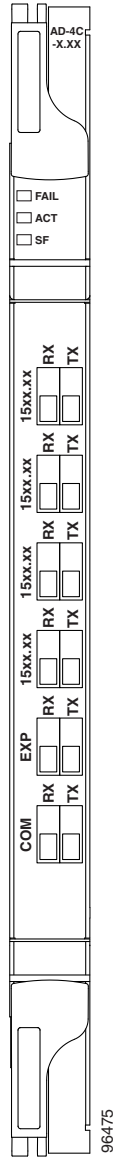

For information on safety labels for the card, see the “9.2 Safety Labels” section on page 9-9.

Figure 9-8 shows a block diagram of the AD-4C-xx.x card.

Figure 9-8 AD-4C-xx.x Block Diagram

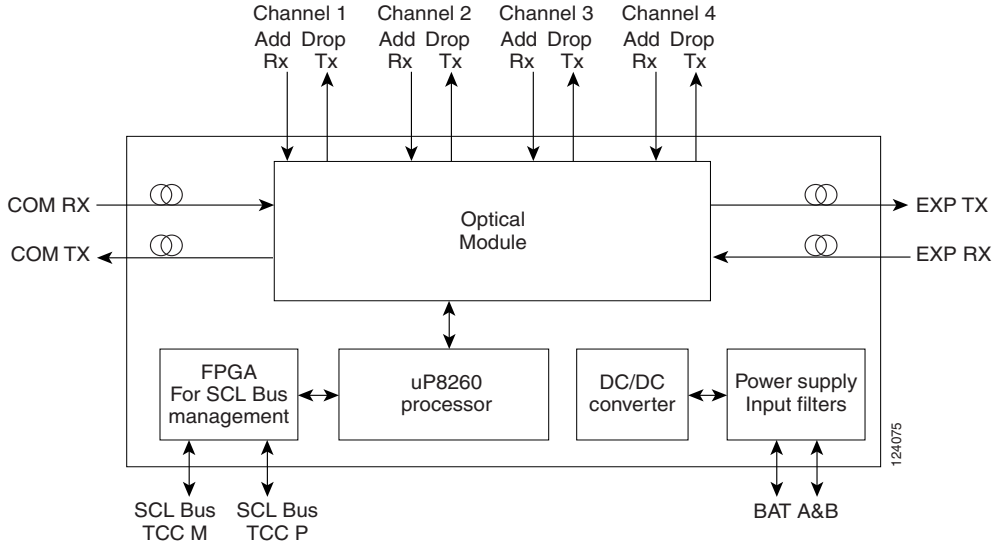
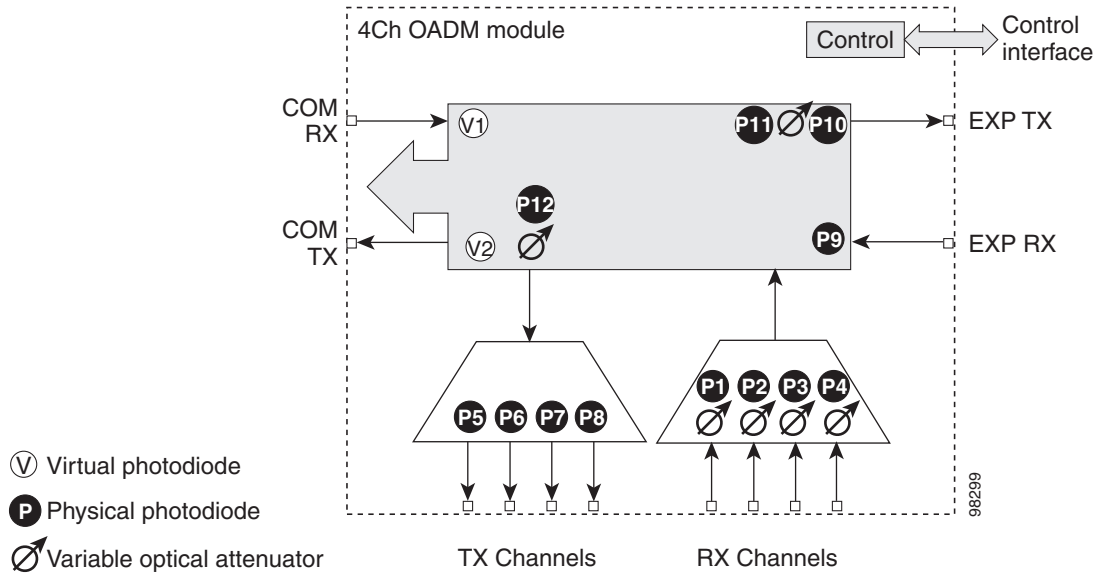

Figure 9-9 shows the AD-4C-xx.x optical module functional block diagram.

Figure 9-9 AD-4C-xx.x Optical Module Functional Block Diagram



## 9.5.2 Wavelength Sets

The AD-4C-xx.x cards are provisioned for the sets of four 100-GHz-spaced wavelengths shown Table 9-11 on page 9-19.

**Table 9-11 AD-4C-xx.x Channel Sets**

Band ID	Add/Drop Wavelengths
Band 30.3 (A)	1530.3, 1531.2, 1531.9, 1532.6
Band 34.2 (B)	1534.2, 1535.0, 1535.8, 1536.6
Band 38.1 (C)	1538.1, 1538.9, 1539.7, 1540.5
Band 42.1 (D)	1542.1, 1542.9, 1543.7, 1544.5
Band 46.1 (E)	1546.1, 1546.9, 1547.7, 1548.5
Band 50.1 (F)	1550.1, 1550.9, 1551.7, 1552.5
Band 54.1 (G)	1554.1, 1554.9, 1555.7, 1556.5
Band 58.1 (H)	1558.1, 1558.9, 1559.7, 1560.6

## 9.5.3 Power Monitoring

Physical photodiodes P1 through P10 and virtual photodiodes V1 and V2 monitor the power for the AD-4C-xx.x card. The returned power level values are calibrated to the ports as shown in [Table 9-12](#).

**Table 9-12 AD-4C-xx.x Port Calibration**

Photodiode	CTC Type Name	Calibrated to Port
P1–P4	ADD	COM TX
P5–P8	DROP	DROP TX
P9	IN EXP	EXP RX
P10	OUT EXP	EXP TX
V1	IN COM	COM RX
V2	OUT COM	COM TX

For information on the associated TL1 AIDs for the optical power monitoring points, refer the “CTC Port Numbers and TL1 Aids” section in *Cisco ONS SONET TL1 Command Guide, Release 9.2.1*.

## 9.5.4 AD-4C-xx.x Card Functions

- Card level indicators—[Table G-4 on page G-9](#)
- “[G.4 Port-Level Indicators](#)” section on page G-10

## 9.5.5 Related Procedures for AD-4C-xx.x Card

The following section lists procedures and tasks related to the configuration of the AD-4C-xx.x card:

- “[NTP-G30 Install the DWDM Cards](#)” procedure on page 14-63
- “[NTP-G37 Run Automatic Node Setup](#)” procedure on page 14-124

- “NTP-G59 Create, Delete, and Manage Optical Channel Network Connections” procedure on page 17-40
- “NTP-G51 Verify DWDM Node Turn Up” procedure on page 16-2
- NTP-G74 Monitor DWDM Card Performance
- “NTP-G106 Reset Cards Using CTC” procedure on page 24-14
- NTP-G107 Remove Permanently or Remove and Replace DWDM Cards
- “NTP-G119 Power Down the Node” procedure on page 24-23

## 9.6 AD-1B-xx.x Card

(Cisco ONS 15454 only)



### Note

For AD-1B-xx.x card specifications, see the “[AD-1B-xx.x Card Specifications](#)” section in the Hardware Specifications document.

The 1-Band OADM (AD-1B-xx.x) card passively adds or drops a single band of four adjacent 100-GHz-spaced channels. Eight versions of this card with eight different part numbers—each version designed for use with one band of wavelengths—are used in the ONS 15454 DWDM system. The card bidirectionally adds and drops in two different sections on the same card to manage signal flow in both directions. This card can be used when there is asymmetric adding and dropping on each side (east or west) of the node; a band can be added or dropped on one side but not on the other.

The AD-1B xx.x can be installed in Slots 1 to 6 and 12 to 17 and has the following features:

- Passive cascaded interferential filters perform the channel add and drop functions.
- Two software-controlled VOAs regulate the optical power flowing in the express and drop OADM paths (drop section).
- Output power of the dropped band is set by changing the attenuation of the VOA drop.
- The VOA express is used to regulate the insertion loss of the express path.
- VOA settings and functions, photodiode detection, and alarm thresholds are internally controlled.
- Virtual photodiode (firmware calculation of port optical power) at the common DWDM output are monitored within the software.

### 9.6.1 Faceplate and Block Diagrams

Figure 9-10 shows the AD-1B-xx.x faceplate.

**Figure 9-10 AD-1B-xx.x Faceplate**

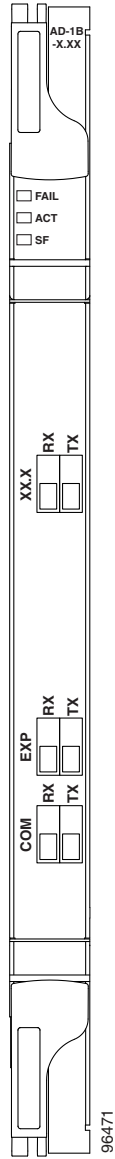

For information on safety labels for the card, see the “9.2 Safety Labels” section on page 9-9.

Figure 9-11 shows a block diagram of the AD-1B-xx.x card.

Figure 9-11 AD-1B-xx.x Block Diagram

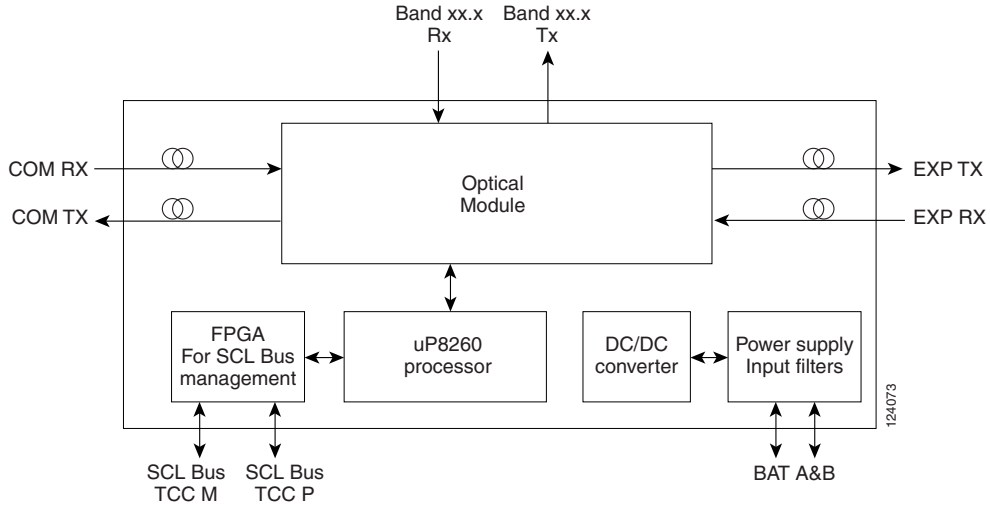
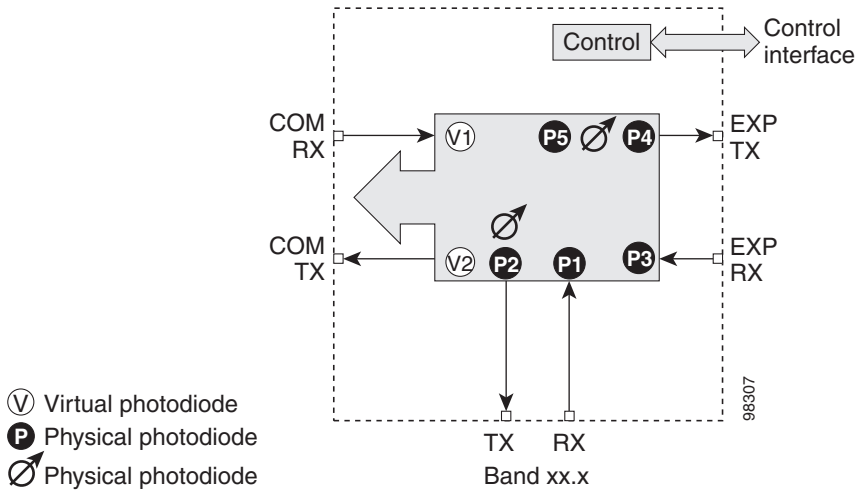

Figure 9-12 shows the AD-1B-xx.x optical module functional block diagram.

Figure 9-12 AD-1B-xx.x Optical Module Functional Block Diagram



## 9.6.2 Power Monitoring

Physical photodiodes P1 through P4 and virtual photodiodes V1 and V2 monitor the power for the AD-1B-xx.x card. The returned power level values are calibrated to the ports as shown in Table 9-13.

Table 9-13 AD-1B-xx.x Port Calibration

Photodiode	CTC Type Name	Calibrated to Port
P1	ADD	BAND RX
P2	DROP	BAND TX

**Table 9-13 AD-1B-xx.x Port Calibration (continued)**

Photodiode	CTC Type Name	Calibrated to Port
P3	IN EXP	EXP RX
P4	OUT EXP	EXP TX
V1	IN COM	COM RX
V2	OUT COM	COM TX

For information on the associated TL1 AIDs for the optical power monitoring points, refer the “CTC Port Numbers and TL1 Aids” section in *Cisco ONS SONET TL1 Command Guide, Release 9.2.1*.

## 9.6.3 AD-1B-xx.x Card Functions

- Card level indicators—[Table G-4 on page G-9](#)
- “G.4 Port-Level Indicators” section on page G-10

## 9.6.4 Related Procedures for AD-1B-xx.x Card

The following section lists procedures and tasks related to the configuration of the AD-1B-xx.x card:

- “NTP-G30 Install the DWDM Cards” procedure on page 14-63
- “NTP-G37 Run Automatic Node Setup” procedure on page 14-124
- “NTP-G59 Create, Delete, and Manage Optical Channel Network Connections” procedure on page 17-40
- “NTP-G51 Verify DWDM Node Turn Up” procedure on page 16-2
- NTP-G74 Monitor DWDM Card Performance
- “NTP-G106 Reset Cards Using CTC” procedure on page 24-14
- NTP-G107 Remove Permanently or Remove and Replace DWDM Cards
- “NTP-G119 Power Down the Node” procedure on page 24-23

## 9.7 AD-4B-xx.x Card

(Cisco ONS 15454 only)

The 4-Band OADM (AD-4B-xx.x) card passively adds or drops four bands of four adjacent 100-GHz-spaced channels. Two versions of this card with different part numbers—each version designed for use with one set of bands—are used in the ONS 15454 DWDM system. The card bidirectionally adds and drops in two different sections on the same card to manage signal flow in both directions. This card can be used when there is asymmetric adding and dropping on each side (east or west) of the node; a band can be added or dropped on one side but not on the other.

The AD1B-xx.x can be installed in Slots 1 to 6 and 12 to 17 and has the following features:

- Five software-controlled VOAs regulate the optical power flowing in the OADM paths.
- Output power of each dropped band is set by changing the attenuation of each VOA drop.

- The VOA express is used to regulate the insertion loss of the express path.
- VOA settings and functions, photodiode detection, and alarm thresholds are internally controlled.
- Virtual photodiode (firmware calculation of port optical power) at the common DWDM output port are monitored within the software.

## 9.7.1 Faceplate and Block Diagrams

Figure 9-13 shows the AD-4B-xx.x faceplate.

**Figure 9-13** AD-4B-xx.x Faceplate

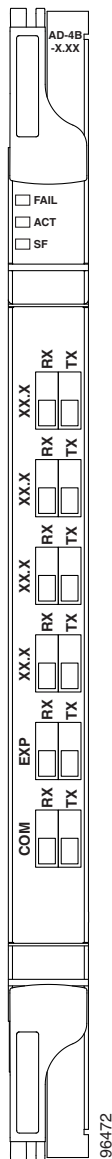

For information on safety labels for the card, see the “9.2 Safety Labels” section on page 9-9.

Figure 9-14 shows a block diagram of the AD-4B-xx.x card.

Figure 9-14 AD-4B-xx.x Block Diagram

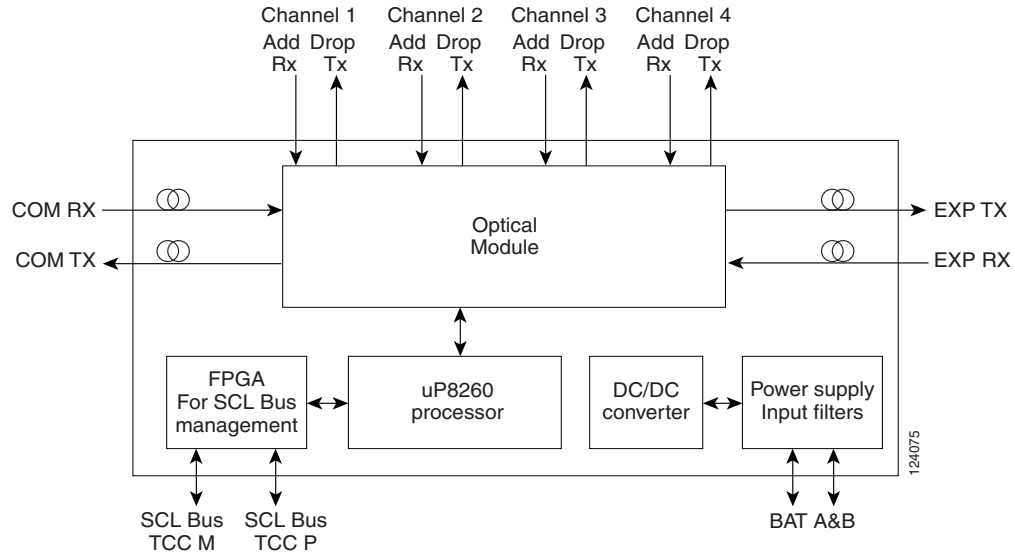
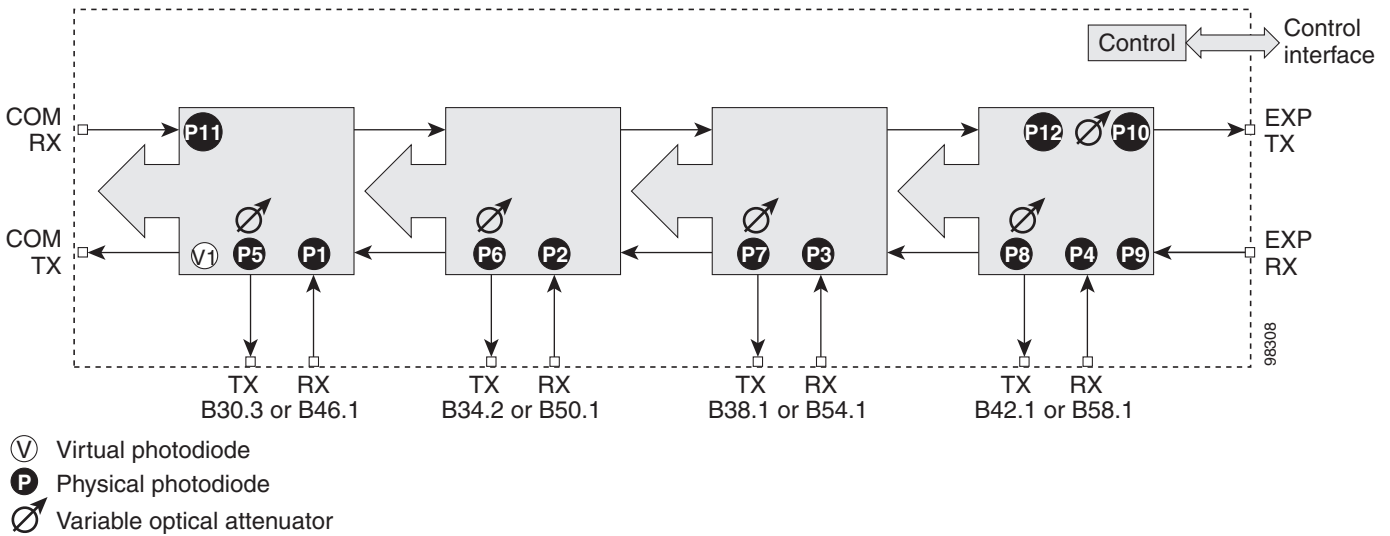

Figure 9-15 shows the AD-4B-xx.x optical module functional block diagram.

Figure 9-15 AD-4B-xx.x Optical Module Functional Block Diagram



## 9.7.2 Power Monitoring

Physical photodiodes P1 through P11 and virtual photodiode V1 monitor the power for the AD-4B-xx.x card. The returned power level values are calibrated to the ports as shown in Table 9-14.

**Table 9-14 AD-4B-xx.x Port Calibration**

Photodiode	CTC Type Name	Calibrated to Port
P1–P4	ADD	COM TX
P5–P8	DROP	DROP TX
P9	IN EXP	EXP RX
P10	OUT EXP	EXP TX
P11	IN COM	COM RX
V1	OUT COM	COM TX

For information on the associated TL1 AIDs for the optical power monitoring points, refer the “CTC Port Numbers and TL1 Aids” section in *Cisco ONS SONET TL1 Command Guide, Release 9.2.1*.

## 9.7.3 AD-4B-xx.x Card Functions

- Card level indicators—[Table G-4 on page G-9](#)
- [“G.4 Port-Level Indicators” section on page G-10](#)

## 9.7.4 Related Procedures for AD-4B-xx.x Card

The following section lists procedures and tasks related to the configuration of the AD-4B-xx.x card:

- [“NTP-G30 Install the DWDM Cards” procedure on page 14-63](#)
- [“NTP-G37 Run Automatic Node Setup” procedure on page 14-124](#)
- [“NTP-G59 Create, Delete, and Manage Optical Channel Network Connections” procedure on page 17-40](#)
- [“NTP-G51 Verify DWDM Node Turn Up” procedure on page 16-2](#)
- [NTP-G74 Monitor DWDM Card Performance](#)
- [“NTP-G106 Reset Cards Using CTC” procedure on page 24-14](#)
- [NTP-G107 Remove Permanently or Remove and Replace DWDM Cards](#)
- [“NTP-G119 Power Down the Node” procedure on page 24-23](#)