



CHAPTER 10

Transponder and Muxponder Cards

**Note**

The terms “Unidirectional Path Switched Ring” and “UPSR” may appear in Cisco literature. These terms do not refer to using Cisco ONS 15xxx products in a unidirectional path switched ring configuration. Rather, these terms, as well as “Path Protected Mesh Network” and “PPMN,” refer generally to Cisco’s path protection feature, which may be used in any topological network configuration. Cisco does not recommend using its path protection feature in any particular topological network configuration.

This chapter describes Cisco ONS 15454 transponder (TXP), muxponder (MXP), GE_XP, 10GE_XP, GE_XPE, 10GE_XPE, ADM-10G, and OTU2_XP cards, as well as their associated plug-in modules (Small Form-factor Pluggables [SFPs or XFPs]). For installation and card turn-up procedures, refer to the *Cisco ONS 15454 DWDM Procedure Guide*. For card safety and compliance information, refer to the *Cisco Optical Transport Products Safety and Compliance Information* document.

**Note**

Unless otherwise specified, “ONS 15454” refers to both ANSI and ETSI shelf assemblies.

**Note**

The cards described in this chapter are supported on the Cisco ONS 15454, Cisco ONS 15454 M6, Cisco ONS 15454 M2 platforms, unless noted otherwise.

Chapter topics include:

- [10.1 Card Overview, page 10-2](#)
- [10.2 Safety Labels, page 10-8](#)
- [10.3 TXP_MR_10G Card, page 10-13](#)
- [10.4 TXP_MR_10E Card, page 10-16](#)
- [10.5 TXP_MR_10E_C and TXP_MR_10E_L Cards, page 10-21](#)
- [10.6 TXP_MR_2.5G and TXPP_MR_2.5G Cards, page 10-25](#)
- [10.7 MXP_2.5G_10G Card, page 10-29](#)
- [10.8 MXP_2.5G_10E_C and MXP_2.5G_10E_L Cards, page 10-40](#)
- [10.9 MXP_MR_2.5G and MXPP_MR_2.5G Cards, page 10-49](#)
- [10.10 MXP_MR_10DME_C and MXP_MR_10DME_L Cards, page 10-55](#)
- [10.11 40G-MXP-C Card, page 10-64](#)
- [10.12 GE_XP, 10GE_XP, GE_XPE, and 10GE_XPE Cards, page 10-71](#)

- [10.13 ADM-10G Card, page 10-97](#)
- [10.14 OTU2_XP Card, page 10-112](#)
- [10.15 MLSE UT, page 10-122](#)
- [10.16 TXP_MR_10EX_C Card, page 10-122](#)
- [10.17 MXP_2.5G_10EX_C card, page 10-126](#)
- [10.18 MXP_MR_10DMEX_C Card, page 10-133](#)
- [10.19 Y-Cable and Splitter Protection, page 10-140](#)
- [10.20 Far-End Laser Control, page 10-143](#)
- [10.21 Jitter Considerations, page 10-143](#)
- [10.22 Termination Modes, page 10-144](#)
- [10.23 SFP and XFP Modules, page 10-145](#)

**Note**

Cisco ONS 15454 DWDM supports IBM's 5G DDR (Double Data Rate) InfiniBand¹ interfaces.

10.1 Card Overview

The card overview section lists the cards described in this chapter and provides compatibility information.

**Note**

Each card is marked with a symbol that corresponds to a slot (or slots) on the ONS 15454 shelf assembly. The cards are then installed into slots displaying the same symbols. For a list of slots and symbols, see the "Card Slot Requirements" section in the *Cisco ONS 15454 Hardware Installation Guide*.

The purpose of a TXP, MXP, GE_XP, 10GE_XP, GE_XPE, 10GE_XPE, ADM-10G, or OTU2_XP card is to convert the “gray” optical client interface signals into trunk signals that operate in the “colored” dense wavelength division multiplexing (DWDM) wavelength range. Client-facing gray optical signals generally operate at shorter wavelengths, whereas DWDM colored optical signals are in the longer wavelength range (for example, 1490 nm = violet; 1510 nm = blue; 1530 nm = green; 1550 nm = yellow; 1570 nm = orange; 1590 nm = red; 1610 nm = brown). Some of the newer client-facing SFPs, however, operate in the colored region. Transponding or muxponding is the process of converting the signals between the client and trunk wavelengths.

An MXP generally handles several client signals. It aggregates, or multiplexes, lower rate client signals together and sends them out over a higher rate trunk port. Likewise, it demultiplexes optical signals coming in on a trunk and sends them out to individual client ports. A TXP converts a single client signal to a single trunk signal and converts a single incoming trunk signal to a single client signal. GE_XP, 10GE_XP, GE_XPE, and 10GE_XPE cards can be provisioned as TXPs, as MXPs, or as Layer 2 switches.

All of the TXP and MXP cards perform optical to electrical to optical (OEO) conversion. As a result, they are not optically transparent cards. The reason for this is that the cards must operate on the signals passing through them, so it is necessary to do an OEO conversion.

1. 5G DDR InfiniBand is referred to as IB_5G.

On the other hand, the termination mode for all of the TXPs and MXPs, which is done at the electrical level, can be configured to be transparent. In this case, neither the Line nor the Section overhead is terminated. The cards can also be configured so that either Line or Section overhead can be terminated, or both can be terminated.

**Note**

The MXP_2.5G_10G card, by design, when configured in the transparent termination mode, actually does terminate some of the bytes. See [Table 10-65 on page 10-144](#) for details.

10.1.1 Card Summary

[Table 10-1](#) lists and summarizes the functions of each TXP, TXPP, MXP, MXPP, GE_XP, 10GE_XP, GE_XPE, 10GE_XPE, ADM-10G, and OTU2_XP card.

Table 10-1 Cisco ONS 15454 Transponder and Muxponder Cards

Card	Port Description	For Additional Information
TXP_MR_10G	The TXP_MR_10G card has two sets of ports located on the faceplate.	See the “ 10.3 TXP_MR_10G Card ” section on page 10-13.
TXP_MR_10E	The TXP_MR_10E card has two sets of ports located on the faceplate.	See the “ 10.4 TXP_MR_10E Card ” section on page 10-16.
TXP_MR_10E_C and TXP_MR_10E_L	The TXP_MR_10E_C and TXP_MR_10E_L cards have two sets of ports located on the faceplate.	See the “ 10.5 TXP_MR_10E_C and TXP_MR_10E_L Cards ” section on page 10-21.
TXP_MR_2.5G	The TXP_MR_2.5G card has two sets of ports located on the faceplate.	See the “ 10.6 TXP_MR_2.5G and TXPP_MR_2.5G Cards ” section on page 10-25.
TXPP_MR_2.5G	The TXPP_MR_2.5G card has three sets of ports located on the faceplate.	See the “ 10.6 TXP_MR_2.5G and TXPP_MR_2.5G Cards ” section on page 10-25.
MXP_2.5G_10G	The MXP_2.5G_10G card has nine sets of ports located on the faceplate.	See the “ 10.7 MXP_2.5G_10G Card ” section on page 10-29.
MXP_2.5G_10E	The MXP_2.5G_10E card has nine sets of ports located on the faceplate.	See the “ 10.7.4 MXP_2.5G_10E Card ” section on page 10-33.
MXP_2.5G_10E_C and MXP_2.5G_10E_L	The MXP_2.5G_10E_C and MXP_2.5G_10E_L cards have nine sets of ports located on the faceplate.	See the “ 10.8 MXP_2.5G_10E_C and MXP_2.5G_10E_L Cards ” section on page 10-40.
MXP_MR_2.5G	The MXP_MR_2.5G card has nine sets of ports located on the faceplate.	See the “ 10.9 MXP_MR_2.5G and MXPP_MR_2.5G Cards ” section on page 10-49.
MXPP_MR_2.5G	The MXPP_MR_2.5G card has ten sets of ports located on the faceplate.	See the “ 10.9 MXP_MR_2.5G and MXPP_MR_2.5G Cards ” section on page 10-49.

Table 10-1 Cisco ONS 15454 Transponder and Muxponder Cards (continued)

Card	Port Description	For Additional Information
MXP_MR_10DME_C and MXP_MR_10DME_L	The MXP_MR_10DME_C and MXP_MR_10DME_L cards have eight sets of ports located on the faceplate.	See the “10.10 MXP_MR_10DME_C and MXP_MR_10DME_L Cards” section on page 10-55.
40G-MXP-C	The 40G-MXP-C card has five ports located on the faceplate.	See the “10.11 40G-MXP-C Card” section on page 10-64.
GE_XP and GE_XPE	The GE_XP and GE_XPE cards have twenty Gigabit Ethernet client ports and two 10 Gigabit Ethernet trunk ports.	See the “10.12 GE_XP, 10GE_XP, GE_XPE, and 10GE_XPE Cards” section on page 10-71.
10GE_XP and 10GE_XPE	The 10GE_XP and 10GE_XPE cards have two 10 Gigabit Ethernet client ports and two 10 Gigabit Ethernet trunk ports.	See the “10.12 GE_XP, 10GE_XP, GE_XPE, and 10GE_XPE Cards” section on page 10-71.
ADM-10G	The ADM-10G card has 19 sets of ports located on the faceplate.	See the “10.13 ADM-10G Card” section on page 10-97.
OTU2_XP	The OTU2_XP card has four ports located on the faceplate.	See the “10.14 OTU2_XP Card” section on page 10-112.
TXP_MR_10EX_C	The TXP_MR_10EX_C card has two sets of ports located on the faceplate.	See the “10.16 TXP_MR_10EX_C Card” section on page 10-122.
MXP_2.5G_10EX_C	The MXP_2.5G_10EX_C card has nine sets of ports located on the faceplate.	See the “10.17 MXP_2.5G_10EX_C card” section on page 10-126.
MXP_MR_10DMEX_C	The MXP_MR_10DMEX_C card has eight sets of ports located on the faceplate.	See the “10.18 MXP_MR_10DMEX_C Card” section on page 10-133.

10.1.2 Card Compatibility

Table 10-2 lists the platform and Cisco Transport Controller (CTC) software compatibility for each TXP, TXPP, MXP, MXPP, GE_XP, 10GE_XP, GE_XPE, 10GE_XPE, ADM-10G, and OTU2_XP card.

Table 10-2 Platform and Software Release Compatibility for Transponder and Muxponder Cards

Card Name	R4.5	R4.6	R4.7	R5.0	R6.0	R7.0	R7.2	R8.0	R8.5	R9.0	R9.1	R9.2
TXP_MR_10G	15454 -DW DM	15454 -DW DM	15454 -DW DM	15454 -DW DM	15454 -DW DM	15454 -DW DM	15454 -DW DM	15454 -DW DM	15454 -DW DM	15454 -DW DM	15454 -DW DM	15454 -DWD M
TXP_MR_10E	No	No	15454 -DW DM	15454 -DW DM	15454 -DW DM	15454 -DW DM	15454 -DW DM	15454 -DW DM	15454 -DW DM	15454 -DW DM	15454 -DW DM	15454 -DWD M
TXP_MR_10E_C	No	No	No	No	No	15454 -DW DM	15454 -DW DM	15454 -DW DM	15454 -DW DM	15454 -DW DM	15454 -DW DM	15454 -DWD M, 15454 -M2, 15454 -M6
TXP_MR_10E_L	No	No	No	No	No	15454 -DW DM	15454 -DW DM	15454 -DW DM	15454 -DW DM	15454 -DW DM	15454 -DW DM	15454 -DWD M
TXP_MR_2.5G	15454 -DW DM	15454 -DW DM	15454 -DW DM	15454 -DW DM	15454 -DW DM	15454 -DW DM	15454 -DW DM	15454 -DW DM	15454 -DW DM	15454 -DW DM	15454 -DW DM	15454 -DWD M, 15454 -M2, 15454 -M6
TXPP_MR_2.5G	15454 -DW DM	15454 -DW DM	15454 -DW DM	15454 -DW DM	15454 -DW DM	15454 -DW DM	15454 -DW DM	15454 -DW DM	15454 -DW DM	15454 -DW DM	15454 -DW DM	15454 -DWD M, 15454 -M2, 15454 -M6
MXP_2.5G_10G	15454 -DW DM	15454 -DW DM	15454 -DW DM	15454 -DW DM	15454 -DW DM	15454 -DW DM	15454 -DW DM	15454 -DW DM	15454 -DW DM	15454 -DW DM	15454 -DW DM	15454 -DWD M
MXP_2.5G_10E	No	No	15454 -DW DM	15454 -DW DM	15454 -DW DM	15454 -DW DM	15454 -DW DM	15454 -DW DM	15454 -DW DM	15454 -DW DM	15454 -DW DM	15454 -DWD M

Table 10-2 Platform and Software Release Compatibility for Transponder and Muxponder Cards

Card Name	R4.5	R4.6	R4.7	R5.0	R6.0	R7.0	R7.2	R8.0	R8.5	R9.0	R9.1	R9.2
MXP_2.5G_10E_C	No	No	No	No	No	15454 -DW DM	15454 -DW DM	15454 -DW DM	15454 -DW DM	15454 -DW DM	15454 -DW DM	15454 -DWD M, 15454 -M2, 15454 -M6
MXP_2.5G_10E_L	No	No	No	No	No	15454 -DW DM	15454 -DW DM	15454 -DW DM	15454 -DW DM	15454 -DW DM	15454 -DW DM	15454 -DWD M
MXP_MR_2.5G	No	No	15454 -DW DM	15454 -DW DM	15454 -DW DM	15454 -DW DM	15454 -DW DM	15454 -DW DM	15454 -DW DM	15454 -DW DM	15454 -DW DM	15454 -DWD M, 15454 -M2, 15454 -M6
MXPP_MR_2.5G	No	No	15454 -DW DM	15454 -DW DM	15454 -DW DM	15454 -DW DM	15454 -DW DM	15454 -DW DM	15454 -DW DM	15454 -DW DM	15454 -DW DM	15454 -DWD M, 15454 -M2, 15454 -M6
MXP_MR_10DME_C	No	No	No	No	No	15454 -DW DM	15454 -DW DM	15454 -DW DM	15454 -DW DM	15454 -DW DM	15454 -DW DM	15454 -DWD M, 15454 -M2, 15454 -M6
MXP_MR_10DME_L	No	No	No	No	No	15454 -DW DM	15454 -DW DM	15454 -DW DM	15454 -DW DM	15454 -DW DM	15454 -DW DM	15454 -DWD M
GE_XP	No	No	No	No	No	No	No	15454 -DW DM	15454 -DW DM	15454 -DW DM	15454 -DW DM	15454 -DWD M, 15454 -M2, 15454 -M6

Table 10-2 Platform and Software Release Compatibility for Transponder and Muxponder Cards

Card Name	R4.5	R4.6	R4.7	R5.0	R6.0	R7.0	R7.2	R8.0	R8.5	R9.0	R9.1	R9.2
10GE_XP	No	No	No	No	No	No	No	15454-DW DM	15454-DW DM	15454-DW DM	15454-DW DM	15454-DWD M, 15454-M2, 15454-M6
GE_XPE	No	No	No	No	No	No	No	No	No	15454-DW DM	15454-DW DM	15454-DWD M, 15454-M2, 15454-M6
10GE_XPE	No	No	No	No	No	No	No	No	No	15454-DW DM	15454-DW DM	15454-DWD M, 15454-M2, 15454-M6
ADM-10G	No	No	No	No	No	No	No	15454-DW DM	15454-DW DM	15454-DW DM	15454-DW DM	15454-DWD M, 15454-M2, 15454-M6
OTU2_XP	No	No	No	No	No	No	No	No	No	15454-DW DM	15454-DW DM	15454-DWD M, 15454-M2, 15454-M6
TXP_MR_10EX_C	No	No	No	No	No	No	No	No	No	No	15454-DW DM	15454-DWD M, 15454-M2, 15454-M6

Table 10-2 Platform and Software Release Compatibility for Transponder and Muxponder Cards

Card Name	R4.5	R4.6	R4.7	R5.0	R6.0	R7.0	R7.2	R8.0	R8.5	R9.0	R9.1	R9.2
MXP_2.5G_10EX_C	No	No	No	No	No	No	No	No	No	No	15454-DWDM	15454-DWDM, 15454-M2, 15454-M6
MXP_MR_10DMEX_C	No	No	No	No	No	No	No	No	No	No	15454-DWDM	15454-DWDM, 15454-M2, 15454-M6
40G-MXP-C	No	No	No	No	No	No	No	No	No	No	No	15454-DWDM, 15454-M2, 15454-M6

Older versions of the TXP_MR_10E_C, TXP_MR_2.5G, TXPP_MR_2.5G, and MXP_2.5G_10E_C cards cannot be installed in the Cisco ONS 15454 M2 and Cisco ONS 15454 M6 shelves because of an incompatible backplane connector.

The following table describes the version numbers of the cards that are compatible with the ONS 15454 M2 and ONS 15454 M6 shelves. The version numbers can be viewed from the HW Rev field in the Inventory tab.

Table 10-3 Version Number Compatibility for Transponder and Muxponder Cards

Card	Version Number
TXP_MR_2.5G	Version 06 or later of the different Unit Part Number
TXPP_MR_2.5G	Version 06 or later of the different Unit Part Number
MXP_2.5G_10E_C	Version 04 or later of the 800-26774 Part Number
TXP_MR_10E_C	Version 04 or later of the 800-26772 Part Number

10.2 Safety Labels

This section explains the significance of the safety labels attached to some of the cards. The faceplates of the cards are clearly labeled with warnings about the laser radiation levels. You must understand all warning labels before working on these cards.

10.2.1 Class 1 Laser Product Cards

The MXP_2.5G_10G, MXP_2.5G_10E, MXP_2.5G_10E_C, MXP_2.5G_10E_L, ADM-10G, GE_XP, 10GE_XP, GE_XPE, 10GE_XPE, and OTU2_XP cards have Class 1 lasers. The labels that appear on these cards are described in the following sections.

10.2.1.1 Class 1 Laser Product Label

The Class 1 Laser Product label is shown in [Figure 10-1](#).

Figure 10-1 Class 1 Laser Product Label

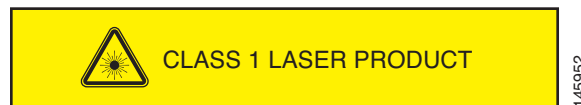

Class 1 lasers are products whose irradiance does not exceed the Maximum Permissible Exposure (MPE) value. Therefore, for Class 1 laser products the output power is below the level at which it is believed eye damage will occur. Exposure to the beam of a Class 1 laser will not result in eye injury and can therefore be considered safe. However, some Class 1 laser products might contain laser systems of a higher Class but there are adequate engineering control measures to ensure that access to the beam is not reasonably likely. Anyone who dismantles a Class 1 laser product that contains a higher Class laser system is potentially at risk of exposure to a hazardous laser beam.

10.2.1.2 Hazard Level 1 Label

The Hazard Level 1 label is shown in [Figure 10-2](#). This label is displayed on the faceplate of the cards.

Figure 10-2 Hazard Level Label



The Hazard Level label warns users against exposure to laser radiation of Class 1 limits calculated in accordance with IEC60825-1 Ed.1.2.

10.2.1.3 Laser Source Connector Label

The Laser Source Connector label is shown in [Figure 10-3](#).

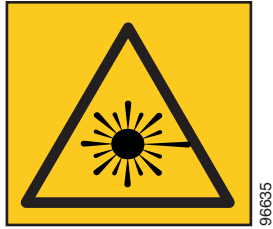
Figure 10-3 Laser Source Connector Label

This label indicates that a laser source is present at the optical connector where the label has been placed.

10.2.1.4 FDA Statement Label

The FDA Statement labels are shown in [Figure 10-4](#) and [Figure 10-5](#). These labels show compliance to FDA standards and that the hazard level classification is in accordance with IEC60825-1 Am.2 or Ed.1.2.

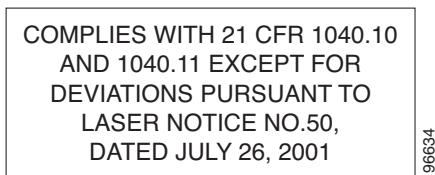
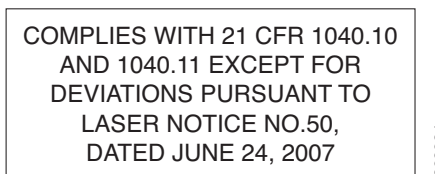
Figure 10-4 FDA Statement Label**Figure 10-5 FDA Statement Label**

10.2.1.5 Shock Hazard Label

The Shock Hazard label is shown in [Figure 10-6](#).

Figure 10-6 Shock Hazard Label



This label alerts personnel to electrical hazard within the card. The potential of shock hazard exists when removing adjacent cards during maintenance, and touching exposed electrical circuitry on the card itself.

10.2.2 Class 1M Laser Product Cards

The TXP_MR_10G, TXP_MR_10E, TXP_MR_10E_C, TXP_MR_10E_L, TXP_MR_2.5G, TXPP_MR_2.5G, MXP_MR_2.5G, MXPP_MR_2.5G, MXP_MR_10DME_C, MXP_MR_10DME_L, and 40G-MXP-C cards have Class 1M lasers.

The labels that appear on these cards are described in the following subsections.

10.2.2.1 Class 1M Laser Product Statement

The Class 1M Laser Product statement is shown in [Figure 10-7](#).

Figure 10-7 Class 1M Laser Product Statement



Class 1M lasers are products that produce either a highly divergent beam or a large diameter beam. Therefore, only a small part of the whole laser beam can enter the eye. However, these laser products can be harmful to the eye if the beam is viewed using magnifying optical instruments.

10.2.2.2 Hazard Level 1M Label

The Hazard Level 1M label is shown in [Figure 10-8](#). This label is displayed on the faceplate of the cards.

Figure 10-8 Hazard Level Label

The Hazard Level label warns users against exposure to laser radiation of Class 1 limits calculated in accordance with IEC60825-1 Ed.1.2.

10.2.2.3 Laser Source Connector Label

The Laser Source Connector label is shown in [Figure 10-9](#).

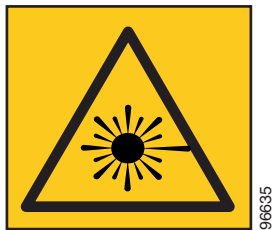
Figure 10-9 Laser Source Connector Label

This label indicates that a laser source is present at the optical connector where the label has been placed.

10.2.2.4 FDA Statement Label

The FDA Statement labels are shown in [Figure 10-10](#) and [Figure 10-11](#). These labels show compliance to FDA standards and that the hazard level classification is in accordance with IEC60825-1 Am.2 or Ed.1.2.

Figure 10-10 FDA Statement Label

Figure 10-11 FDA Statement Label

10.2.2.5 Shock Hazard Label

The Shock Hazard label is shown in [Figure 10-12](#).

Figure 10-12 Shock Hazard Label

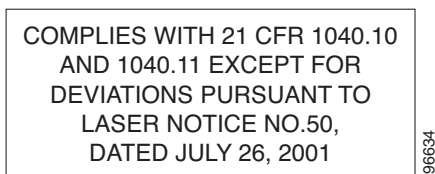
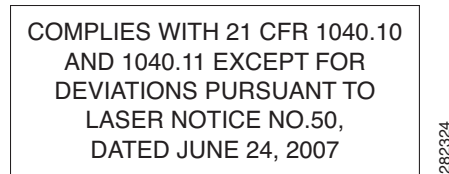
This label alerts personnel to electrical hazard within the card. The potential of shock hazard exists when removing adjacent cards during maintenance, and touching exposed electrical circuitry on the card itself.

10.3 TXP_MR_10G Card

(Cisco ONS 15454 only)

The TXP_MR_10G processes one 10-Gbps signal (client side) into one 10-Gbps, 100-GHz DWDM signal (trunk side). It provides one 10-Gbps port per card that can be provisioned for an STM-64/OC-192 short reach (1310-nm) signal, compliant with ITU-T G.707, ITU-T G.709, ITU-T G.691, and Telcordia GR-253-CORE, or a 10GBASE-LR signal compliant with IEEE 802.3.

The TXP_MR_10G card is tunable over two neighboring wavelengths in the 1550-nm, ITU 100-GHz range. It is available in 16 different versions, each of which covers two wavelengths, for a total coverage of 32 different wavelengths in the 1550-nm range.



Note

ITU-T G.709 specifies a form of forward error correction (FEC) that uses a “wrapper” approach. The digital wrapper lets you transparently take in a signal on the client side, wrap a frame around it and restore it to its original form. FEC enables longer fiber links because errors caused by the optical signal degrading with distance are corrected.

The trunk port operates at 9.95328 Gbps (or 10.70923 Gbps with ITU-T G.709 Digital Wrapper/FEC) and at 10.3125 Gbps (or 11.095 Gbps with ITU-T G.709 Digital Wrapper/FEC) over unamplified distances up to 80 km (50 miles) with different types of fiber such as C-SMF or dispersion compensated fiber limited by loss and/or dispersion.

**Caution**

Because the transponder has no capability to look into the payload and detect circuits, a TXP_MR_10G card does not display circuits under card view.

**Caution**

You must use a 15-dB fiber attenuator (10 to 20 dB) when working with the TXP_MR_10G card in a loopback on the trunk port. Do not use direct fiber loopbacks with the TXP_MR_10G card. Using direct fiber loopbacks causes irreparable damage to the TXP_MR_10G card.

You can install TXP_MR_10G cards in Slots 1 to 6 and 12 to 17 and provision this card in a linear configuration. TXP_MR_10G cards cannot be provisioned as a bidirectional line switched ring (BLSR)/Multiplex Section - Shared Protection Ring (MS-SPRing), a path protection/single node control point (SNCP), or a regenerator. They can only be used in the middle of BLSR/MS-SPRing and 1+1 spans when the card is configured for transparent termination mode.

The TXP_MR_10G port features a 1550-nm laser for the trunk port and a 1310-nm laser for the for the client port and contains two transmit and receive connector pairs (labeled) on the card faceplate.

The MTU setting is used to display the OverSizePkts counters on the receiving trunk and client port interfaces. Traffic of frame sizes up to 65535 bytes pass without any packet drops, from the client port to the trunk port and vice versa irrespective of the MTU setting.

[Figure 10-13](#) shows the TXP_MR_10G faceplate and block diagram.

Figure 10-13 TXP_MR_10G Faceplate and Block Diagram

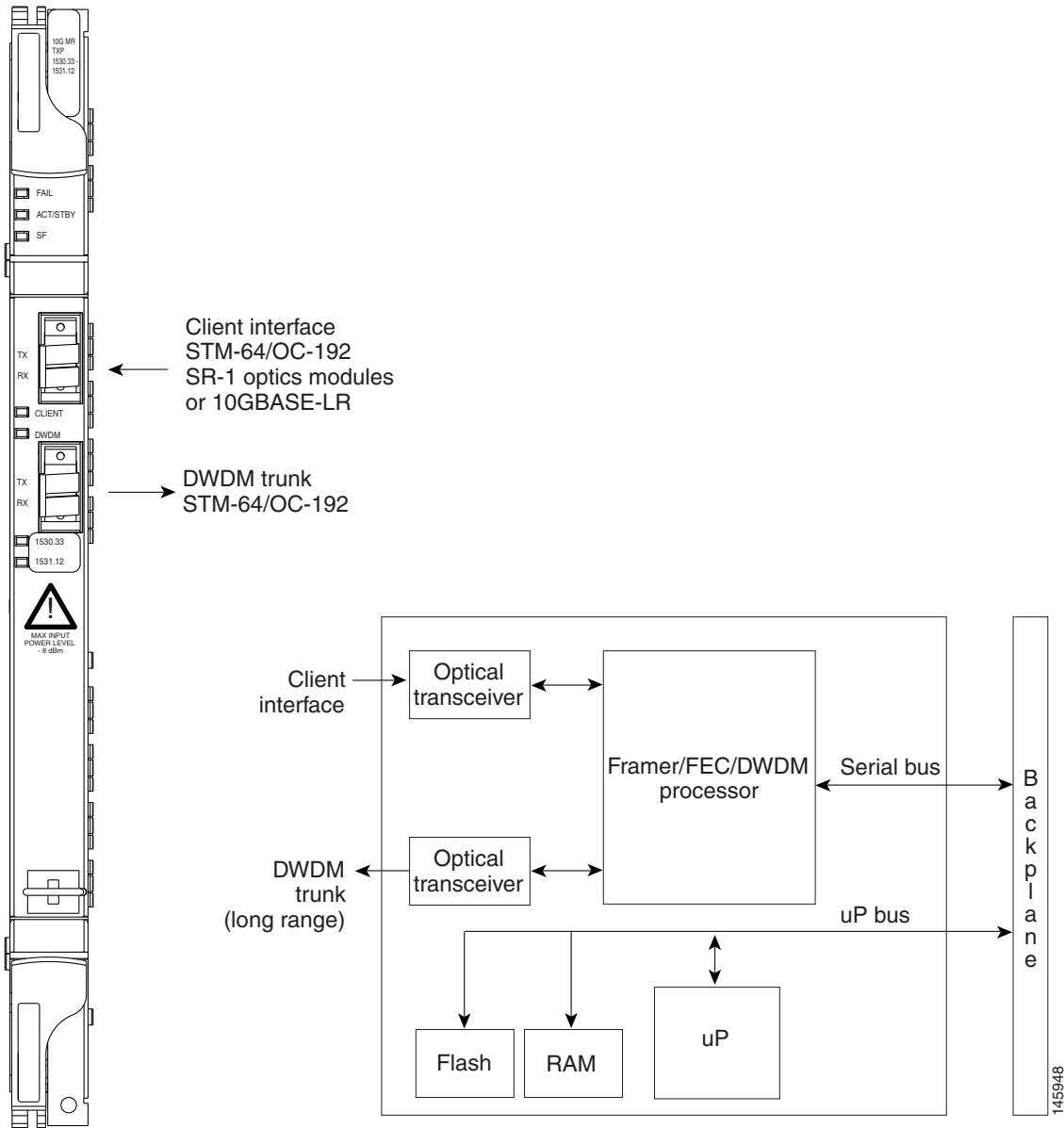

For information on safety labels for the card, see the “10.2.2 Class 1M Laser Product Cards” section on page 10-11.

10.3.1 Automatic Laser Shutdown

The Automatic Laser Shutdown (ALS) procedure is supported on both client and trunk interfaces. On the client interface, ALS is compliant with ITU-T G.664 (6/99). On the data application and trunk interface, the switch on and off pulse duration is greater than 60 seconds and is user-configurable. For details on ALS provisioning for the card, refer to the *Cisco ONS 15454 DWDM Procedure Guide*.

10.3.2 TXP_MR_10G Card-Level Indicators

Table 10-4 lists the three card-level LEDs on the TXP_MR_10G card.

Table 10-4 TXP_MR_10G Card-Level Indicators

Card-Level LED	Description
FAIL LED (Red)	Red indicates that the card's processor is not ready. This LED is on during reset. The FAIL LED flashes during the boot process. Replace the card if the red FAIL LED persists.
ACT/STBY LED Green (Active) Amber (Standby)	Green indicates that the card is operational (one or both ports active) and ready to carry traffic. Amber indicates that the card is operational and in standby (protect) mode.
SF LED (Amber)	Amber indicates a signal failure or condition such as loss of signal (LOS), loss of frame (LOF), or high bit error rates (BERs) on one or more of the card's ports. The amber SF LED is also illuminated if the transmit and receive fibers are incorrectly connected. If the fibers are properly connected and the link is working, the LED turns off.

10.3.3 TXP_MR_10G Port-Level Indicators

Table 10-5 lists the four port-level LEDs in the TXP_MR_10G card.

Table 10-5 TXP_MR_10G Port-Level Indicators

Port-Level LED	Description
Green Client LED	The green Client LED indicates that the client port is in service and that it is receiving a recognized signal.
Green DWDM LED	The green DWDM LED indicates that the DWDM port is in service and that it is receiving a recognized signal.
Green Wavelength 1 LED	Each port supports two wavelengths on the DWDM side. Each wavelength LED matches one of the wavelengths. This LED indicates that the card is configured for Wavelength 1.
Green Wavelength 2 LED	Each port supports two wavelengths on the DWDM side. Each wavelength LED matches one of the wavelengths. This LED indicates that the card is configured for Wavelength 2.

10.4 TXP_MR_10E Card

The TXP_MR_10E card is a multirate transponder for the ONS 15454 platform. The card is fully backward compatible with the TXP_MR_10G card. It processes one 10-Gbps signal (client side) into one 10-Gbps, 100-GHz DWDM signal (trunk side) that is tunable over four wavelength channels (spaced at 100 GHz on the ITU grid) in the C band and tunable over eight wavelength channels (spaced at 50 GHz on the ITU grid) in the L band. There are eight versions of the C-band card, with each version covering four wavelengths, for a total coverage of 32 wavelengths. There are five versions of the L-band card, with each version covering eight wavelengths, for a total coverage of 40 wavelengths.

You can install TXP_MR_10E cards in Slots 1 to 6 and 12 to 17 and provision the cards in a linear configuration, BLSR/MS-SPRing, path protection/SNCP, or a regenerator. The card can be used in the middle of BLSR/MS-SPRing or 1+1 spans when the card is configured for transparent termination mode.

The TXP_MR_10E card features a 1550-nm tunable laser (C band) or a 1580-nm tunable laser (L band) for the trunk port and a separately orderable ONS-XC-10G-S1 1310-nm or ONS-XC-10G-L2 1550-nm laser XFP module for the client port.

**Note**

When the ONS-XC-10G-L2 XFP is installed, the TXP_MR_10E card must be installed in Slots 6, 7, 12 or 13)

On its faceplate, the TXP_MR_10E card contains two transmit and receive connector pairs, one for the trunk port and one for the client port. Each connector pair is labeled.

10.4.1 Key Features

The key features of the TXP_MR_10E card are:

- A tri-rate client interface (available through the ONS-XC-10G-S1 XFP, ordered separately)
 - OC-192 (SR1)
 - 10GE (10GBASE-LR)
 - 10G-FC (1200-SM-LL-L)
- OC-192 to ITU-T G.709 OTU2 provisionable synchronous and asynchronous mapping
- The MTU setting is used to display the OverSizePkts counters on the receiving trunk and client port interfaces. Traffic of frame sizes up to 65535 bytes pass without any packet drops, from the client port to the trunk port and vice versa irrespective of the MTU setting.

10.4.2 Faceplate and Block Diagram

Figure 10-14 shows the TXP_MR_10E faceplate and block diagram.

Figure 10-14 TXP_MR_10E Faceplate and Block Diagram

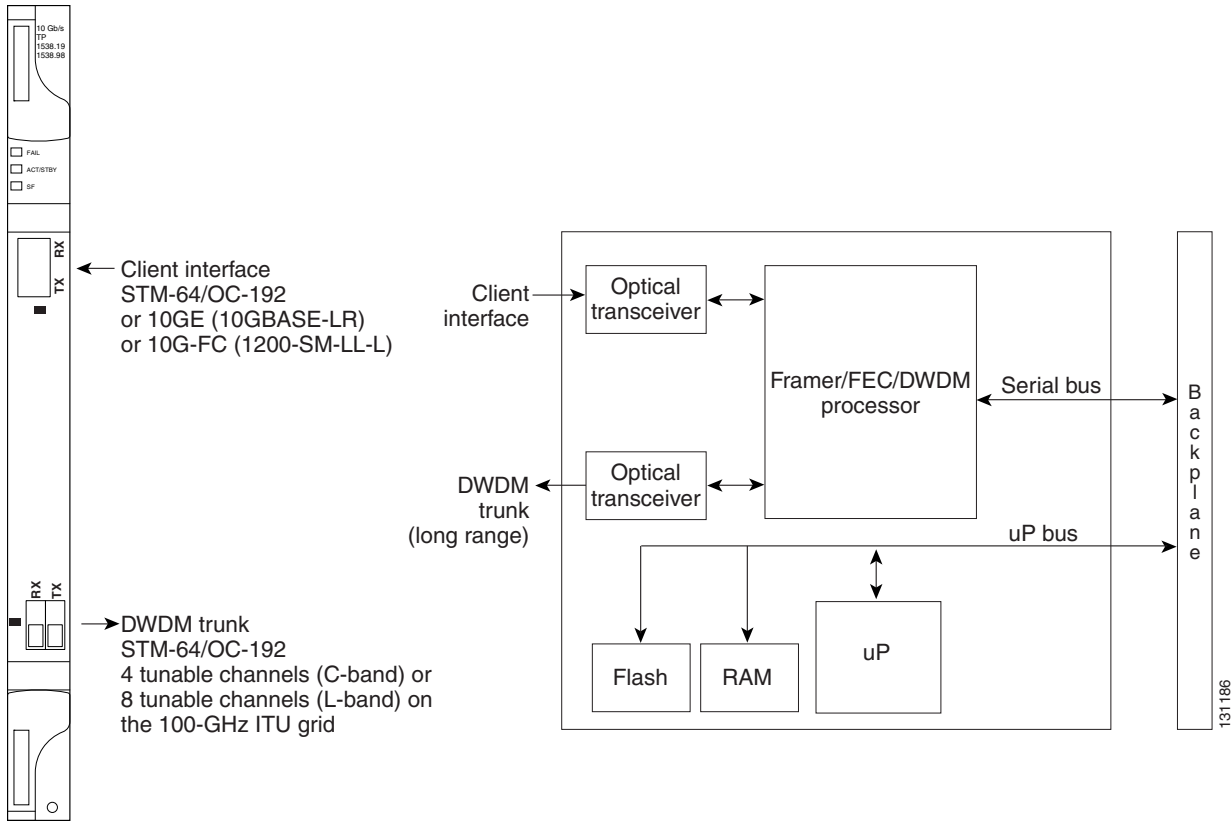

For information on safety labels for the card, see the “[10.2.2 Class 1M Laser Product Cards](#)” section on page 10-11.



Caution

You must use a 15-dB fiber attenuator (10 to 20 dB) when working with the TXP_MR_10E card in a loopback on the trunk port. Do not use direct fiber loopbacks with the TXP_MR_10E card. Using direct fiber loopbacks causes irreparable damage to the TXP_MR_10E card.

10.4.3 Client Interface

The client interface is implemented with a separately orderable XFP module. The module is a tri-rate transceiver, providing a single port that can be configured in the field to support an OC-192 SR-1 (Telcordia GR-253-CORE) or STM-64 I-64.1 (ITU-T G.691) optical interface, as well as 10GE LAN PHY (10GBASE-LR), 10GE WAN PHY (10GBASE-LW), or 10G FC signals.

The client side XFP pluggable module supports LC connectors and is equipped with a 1310-nm laser.

10.4.4 DWDM Trunk Interface

On the trunk side, the TXP_MR_10E card provides a 10-Gbps STM-64/OC-192 interface. There are four tunable channels available in the 1550-nm band or eight tunable channels available in the 1580-nm band on the 50-GHz ITU grid for the DWDM interface. The TXP_MR_10E card provides 3R (retime, reshape,

and regenerate) transponder functionality for this 10-Gbps trunk interface. Therefore, the card is suited for use in long-range amplified systems. The DWDM interface is compliant with ITU-T G.707, ITU-T G.709, and Telcordia GR-253-CORE standards.

The DWDM trunk port operates at a rate that is dependent on the input signal and the presence or absence of the ITU-T G.709 Digital Wrapper/FEC. The possible trunk rates are:

- OC192 (9.95328 Gbps)
- OTU2 (10.70923 Gbps)
- 10GE (10.3125 Gbps) or 10GE into OTU2 (ITU G.sup43 11.0957 Gbps)
- 10G FC (10.51875 Gbps) or 10G FC into OTU2 (nonstandard 11.31764 Gbps)

The maximum system reach in filterless applications without the use of optical amplification or regenerators is nominally rated at 23 dB over C-SMF fiber. This rating is not a product specification, but is given for informational purposes. It is subject to change.

10.4.5 Enhanced FEC (E-FEC) Feature

A key feature of the TXP_MR_10E is the availability to configure the forward error correction in three modes: NO FEC, FEC, and E-FEC. The output bit rate is always 10.7092 Gbps as defined in ITU-T G.709, but the error coding performance can be provisioned as follows:

- NO FEC—No forward error correction
- FEC—Standard ITU-T G.975 Reed-Solomon algorithm
- E-FEC—Standard ITU-T G.975.1 I.7 algorithm, which is a super FEC code



Note

The E-FEC of the ONS 15454 and Cisco ASR 9000 are not compatible.

10.4.6 FEC and E-FEC Modes

As client side traffic passes through the TXP_MR_10E card, it can be digitally wrapped using FEC mode, E-FEC mode, or no error correction at all. The FEC mode setting provides a lower level of error detection and correction than the E-FEC mode setting of the card. As a result, using E-FEC mode allows higher sensitivity (lower optical signal-to-noise ratio [OSNR]) with a lower bit error rate than FEC mode. E-FEC enables longer distance trunk-side transmission than with FEC.

The E-FEC feature is one of three basic modes of FEC operation. FEC can be turned off, FEC can be turned on, or E-FEC can be turned on to provide greater range and lower BER. The default mode is FEC on and E-FEC off. E-FEC is provisioned using CTC.



Caution

Because the transponder has no visibility into the data payload and detect circuits, the TXP_MR_10E card does not display circuits under the card view.

10.4.7 Client-to-Trunk Mapping

The TXP_MR_10E card can perform ODU2-to-OCh mapping, which allows operators to provision data payloads in a standard way across 10-Gbps optical links.

Digital wrappers that define client side interfaces are called Optical Data Channel Unit 2 (ODU2) entities in ITU-T G.709. Digital wrappers that define trunk side interfaces are called Optical Channels (OCh) in ITU-T G.709. ODU2 digital wrappers can include Generalized Multiprotocol Label Switching (G-MPLS) signaling extensions to ITU-T G.709 (such as Least Significant Part [LSP] and Generalized Payload Identifier [G-PID] values) to define client interfaces and payload protocols.

10.4.8 Automatic Laser Shutdown

The ALS procedure is supported on both client and trunk interfaces. On the client interface, ALS is compliant with ITU-T G.664 (6/99). On the data application and trunk interface, the switch on and off pulse duration is greater than 60 seconds. The on and off pulse duration is user-configurable. For details on ALS provisioning for the card, refer to the *Cisco ONS 15454 DWDM Procedure Guide*.

10.4.9 TXP_MR_10E Card-Level Indicators

Table 10-6 lists the three card-level LEDs on the TXP_MR_10E card.

Table 10-6 TXP_MR_10E Card-Level Indicators

Card-Level LED	Description
Red FAIL LED	The red FAIL LED indicates that the card's processor is not ready. This LED is on during reset. The FAIL LED flashes during the boot process. Replace the card if the red FAIL LED persists.
ACT/STBY LED Green (Active) Amber (Standby)	If the ACT/STBY LED is green, the card is operational (one or both ports active) and ready to carry traffic. If the ACT/STBY LED is amber, the card is operational and in standby (protect) mode.
Amber SF LED	The amber SF LED indicates a signal failure or condition such as LOS, LOF, or high BERs on one or more of the card's ports. The amber SF LED is also on if the transmit and receive fibers are incorrectly connected. If the fibers are properly connected and the link is working, the light turns off.

10.4.10 TXP_MR_10E Port-Level Indicators

Table 10-7 lists the two port-level LEDs in the TXP_MR_10E card.

Table 10-7 TXP_MR_10E Port-Level Indicators

Port-Level LED	Description
Green Client LED	The green Client LED indicates that the client port is in service and that it is receiving a recognized signal.
Green DWDM LED	The green DWDM LED indicates that the DWDM port is in service and that it is receiving a recognized signal.

10.5 TXP_MR_10E_C and TXP_MR_10E_L Cards

TXP_MR_10E_L: (Cisco ONS 15454 only)

The TXP_MR_10E_C and TXP_MR_10E_L cards are multirate transponders for the ONS 15454 platform. The cards are fully backward compatible with the TXP_MR_10G and TXP_MR_10E cards. They process one 10-Gbps signal (client side) into one 10-Gbps, 100-GHz DWDM signal (trunk side). The TXP_MR_10E_C is tunable over the entire set of C-band wavelength channels (82 channels spaced at 50 GHz on the ITU grid). The TXP_MR_10E_L is tunable over the entire set of L-band wavelength channels (80 channels spaced at 50 GHz on the ITU grid) and is particularly well suited for use in networks that employ DS fiber or SMF-28 single-mode fiber.

The advantage of these cards over previous versions (TXP_MR_10G and TXP_MR_10E) is that there is only one version of each card (one C-band version and one L-band version) instead of several versions needed to cover each band.

You can install TXP_MR_10E_C and TXP_MR_10E_L cards in Slots 1 to 6 and 12 to 17 and provision the cards in a linear configuration, BLSR/MS-SPRing, path protection/SNCP, or a regenerator. The cards can be used in the middle of BLSR/MS-SPRing or 1+1 spans when the cards are configured for transparent termination mode.

The TXP_MR_10E_C and TXP_MR_10E_L cards feature a universal transponder 2 (UT2) 1550-nm tunable laser (C band) or a UT2 1580-nm tunable laser (L band) for the trunk port and a separately orderable ONS-XC-10G-S1 1310-nm or ONS-XC-10G-L2 1550-nm laser XFP module for the client port.



Note

When the ONS-XC-10G-L2 XFP is installed, the TXP_MR_10E_C or TXP_MR_10E_L card is required to be installed in a high-speed slot (slot 6, 7, 12, or 13)

On its faceplate, the TXP_MR_10E_C and TXP_MR_10E_L cards contain two transmit and receive connector pairs, one for the trunk port and one for the client port. Each connector pair is labeled.

10.5.1 Key Features

The key features of the TXP_MR_10E_C and TXP_MR_10E_L cards are:

- A tri-rate client interface (available through the ONS-XC-10G-S1 XFP, ordered separately):
 - OC-192 (SR1)
 - 10GE (10GBASE-LR)
 - 10G-FC (1200-SM-LL-L)
- A UT2 module tunable through the entire C band (TXP_MR_10E_C card) or L band (TXP_MR_10E_L card). The channels are spaced at 50 GHz on the ITU grid.
- OC-192 to ITU-T G.709 OTU2 provisionable synchronous and asynchronous mapping.
- The MTU setting is used to display the OverSizePkts counters on the receiving trunk and client port interfaces. Traffic of frame sizes up to 65535 bytes pass without any packet drops, from the client port to the trunk port and vice versa irrespective of the MTU setting.

10.5.2 Faceplates and Block Diagram

Figure 10-15 shows the TXP_MR_10E_C and TXP_MR_10E_L faceplates and block diagram.

Figure 10-15 TXP_MR_10E_C and TXP_MR_10E_L Faceplates and Block Diagram

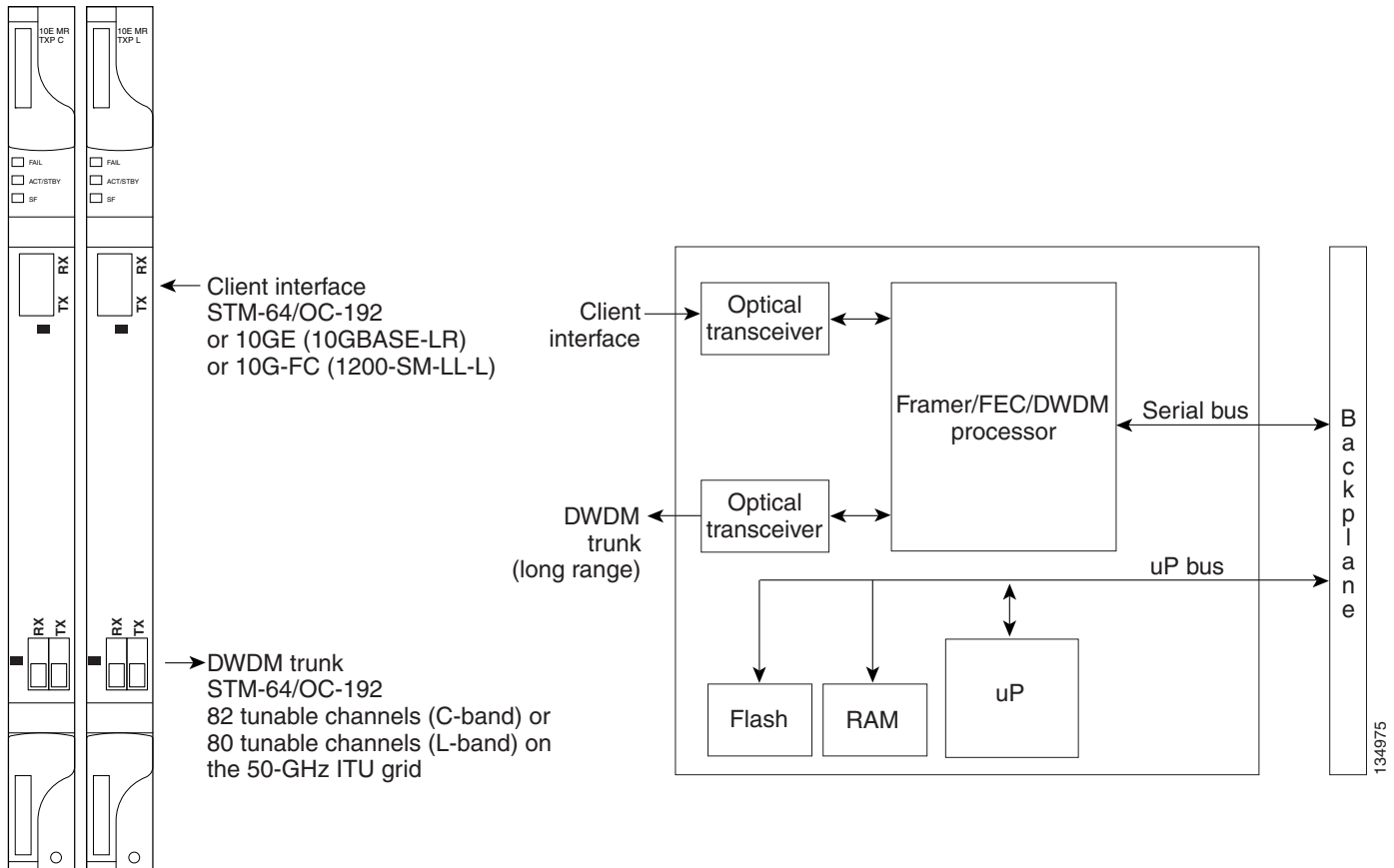

For information on safety labels for the cards, see the “10.2.2 Class 1M Laser Product Cards” section on page 10-11.



Caution

You must use a 15-dB fiber attenuator (10 to 20 dB) when working with the TXP_MR_10E_C or TXP_MR_10E_L card in a loopback on the trunk port. Do not use direct fiber loopbacks with the cards. Using direct fiber loopbacks causes irreparable damage to the cards.

10.5.3 Client Interface

The client interface is implemented with a separately orderable XFP module. The module is a tri-rate transceiver, providing a single port that can be configured in the field to support an OC-192 SR-1 (Telcordia GR-253-CORE) or STM-64 I-64.1 (ITU-T G.691) optical interface, as well as 10GE LAN PHY (10GBASE-LR), 10GE WAN PHY (10GBASE-LW), or 10G-FC signals.

The client side XFP pluggable module supports LC connectors and is equipped with a 1310-nm laser.

10.5.4 DWDM Trunk Interface

On the trunk side, the TXP_MR_10E_C and TXP_MR_10E_L cards provide a 10-Gbps STM-64/OC-192 interface. There are 80 tunable channels available in the 1550-nm C band or 82 tunable channels available in the 1580-nm L band on the 50-GHz ITU grid for the DWDM interface. The TXP_MR_10E_C and TXP_MR_10E_C cards provide 3R transponder functionality for this 10-Gbps trunk interface. Therefore, the card is suited for use in long-range amplified systems. The DWDM interface is compliant with ITU-T G.707, ITU-T G.709, and Telcordia GR-253-CORE standards.

The DWDM trunk port operates at a rate that is dependent on the input signal and the presence or absence of the ITU-T G.709 Digital Wrapper/FEC. The possible trunk rates are:

- OC192 (9.95328 Gbps)
- OTU2 (10.70923 Gbps)
- 10GE (10.3125 Gbps) or 10GE into OTU2 (ITU G.sup43 11.0957 Gbps)
- 10G-FC (10.51875 Gbps) or 10G-FC into OTU2 (nonstandard 11.31764 Gbps)

The maximum system reach in filterless applications without the use of optical amplification or regenerators is nominally rated at 23 dB over C-SMF fiber. This rating is not a product specification, but is given for informational purposes. It is subject to change.

10.5.5 Enhanced FEC (E-FEC) Feature

A key feature of the TXP_MR_10E_C and TXP_MR_10E_L cards is the availability to configure the forward error correction in three modes: NO FEC, FEC, and E-FEC. The output bit rate is always 10.7092 Gbps as defined in ITU-T G.709, but the error coding performance can be provisioned as follows:

- NO FEC—No forward error correction
- FEC—Standard ITU-T G.975 Reed-Solomon algorithm
- E-FEC—Standard ITU-T G.975.1 I.7 algorithm, which is a super FEC code

10.5.6 FEC and E-FEC Modes

As client side traffic passes through the TXP_MR_10E_C and TXP_MR_10E_L cards, it can be digitally wrapped using FEC mode, E-FEC mode, or no error correction at all. The FEC mode setting provides a lower level of error detection and correction than the E-FEC mode setting of the card. As a result, using E-FEC mode allows higher sensitivity (lower OSNR) with a lower bit error rate than FEC mode. E-FEC enables longer distance trunk-side transmission than with FEC.

The E-FEC feature is one of three basic modes of FEC operation. FEC can be turned off, FEC can be turned on, or E-FEC can be turned on to provide greater range and lower BER. The default mode is FEC on and E-FEC off. E-FEC is provisioned using CTC.



Caution

Because the transponder has no visibility into the data payload and detect circuits, the TXP_MR_10E_C and TXP_MR_10E_L cards do not display circuits under the card view.

10.5.7 Client-to-Trunk Mapping

The TXP_MR_10E_C and TXP_MR_10E_L cards can perform ODU2-to-OCh mapping, which allows operators to provision data payloads in a standard way across 10-Gbps optical links.

Digital wrappers that define client side interfaces are called ODU2 entities in ITU-T G.709. Digital wrappers that define trunk side interfaces are called OCh in ITU-T G.709. ODU2 digital wrappers can include G-MPLS signaling extensions to ITU-T G.709 (such as LSP and G-PID values) to define client interfaces and payload protocols.

10.5.8 Automatic Laser Shutdown

The ALS procedure is supported on both client and trunk interfaces. On the client interface, ALS is compliant with ITU-T G.664 (6/99). On the data application and trunk interface, the switch on and off pulse duration is greater than 60 seconds. The on and off pulse duration is user-configurable. For details regarding ALS provisioning for the TXP_MR_10E_C and TXP_MR_10E_L cards, refer to the *Cisco ONS 15454 DWDM Procedure Guide*.

10.5.9 TXP_MR_10E_C and TXP_MR_10E_L Card-Level Indicators

Table 10-8 lists the three card-level LEDs on the TXP_MR_10E_C and TXP_MR_10E_L cards.

Table 10-8 TXP_MR_10E_C and TXP_MR_10E_L Card-Level Indicators

Card-Level LED	Description
Red FAIL LED	The red FAIL LED indicates that the card's processor is not ready. This LED is on during reset. The FAIL LED flashes during the boot process. Replace the card if the red FAIL LED persists.
ACT/STBY LED Green (Active) Amber (Standby)	If the ACT/STBY LED is green, the card is operational (one or both ports active) and ready to carry traffic. If the ACT/STBY LED is amber, the card is operational and in standby (protect) mode.
Amber SF LED	The amber SF LED indicates a signal failure or condition such as LOS, LOF, or high BERs on one or more of the card's ports. The amber SF LED is also on if the transmit and receive fibers are incorrectly connected. If the fibers are properly connected and the link is working, the light turns off.

10.5.10 TXP_MR_10E_C and TXP_MR_10E_L Port-Level Indicators

Table 10-9 lists the two port-level LEDs in the TXP_MR_10E_C and TXP_MR_10E_L cards.

Table 10-9 TXP_MR_10E_C and TXP_MR_10E_L Port-Level Indicators

Port-Level LED	Description
Green Client LED	The green Client LED indicates that the client port is in service and that it is receiving a recognized signal.
Green DWDM LED	The green DWDM LED indicates that the DWDM port is in service and that it is receiving a recognized signal.

10.6 TXP_MR_2.5G and TXPP_MR_2.5G Cards

The TXP_MR_2.5G card processes one 8-Mbps to 2.488-Gbps signal (client side) into one 8-Mbps to 2.5-Gbps, 100-GHz DWDM signal (trunk side). It provides one long-reach STM-16/OC-48 port per card, compliant with ITU-T G.707, ITU-T G.709, ITU-T G.957, and Telcordia GR-253-CORE.

The TXPP_MR_2.5G card processes one 8-Mbps to 2.488-Gbps signal (client side) into two 8-Mbps to 2.5-Gbps, 100-GHz DWDM signals (trunk side). It provides two long-reach STM-16/OC-48 ports per card, compliant with ITU-T G.707, ITU-T G.957, and Telcordia GR-253-CORE.

The TXP_MR_2.5G and TXPP_MR_2.5G cards are tunable over four wavelengths in the 1550-nm, ITU 100-GHz range. They are available in eight versions, each of which covers four wavelengths, for a total coverage of 32 different wavelengths in the 1550-nm range.



Note

ITU-T G.709 specifies a form of FEC that uses a “wrapper” approach. The digital wrapper lets you transparently take in a signal on the client side, wrap a frame around it, and restore it to its original form. FEC enables longer fiber links because errors caused by the optical signal degrading with distance are corrected.

The trunk/line port operates at up to 2.488 Gbps (or up to 2.66 Gbps with ITU-T G.709 Digital Wrapper/FEC) over unamplified distances up to 360 km (223.7 miles) with different types of fiber such as C-SMF or higher if dispersion compensation is used.



Caution

Because the transponder has no capability to look into the payload and detect circuits, a TXP_MR_2.5G or TXPP_MR_2.5G card does not display circuits under card view.

The TXP_MR_2.5G and TXPP_MR_2.5G cards support 2R (retime, regenerate) and 3R (retime, reshape, and regenerate) modes of operation where the client signal is mapped into a ITU-T G.709 frame. The mapping function is simply done by placing a digital wrapper around the client signal. Only OC-48/STM-16 client signals are fully ITU-T G.709 compliant, and the output bit rate depends on the input client signal. [Table 10-10](#) shows the possible combinations of client interfaces, input bit rates, 2R and 3R modes, and ITU-T G.709 monitoring.

Table 10-10 2R and 3R Mode and ITU-T G.709 Compliance by Client Interface

Client Interface	Input Bit Rate	3R vs. 2R	ITU-T G.709
OC-48/STM-16	2.488 Gbps	3R	On or Off
DV-6000	2.38 Gbps	2R	—
2 Gigabit Fibre Channel (2G-FC)/fiber connectivity (FICON)	2.125 Gbps	3R ¹	On or Off
High-Definition Television (HDTV)	1.48 Gbps	2R	—
Gigabit Ethernet (GE)	1.25 Gbps	3R	On or Off
1 Gigabit Fibre Channel (1G-FC)/FICON	1.06 Gbps	3R	On or Off
OC-12/STM-4	622 Mbps	3R	On or Off
OC-3/STM-1	155 Mbps	3R	On or Off
Enterprise System Connection (ESCON)	200 Mbps	2R	—
SDI/D1/DVB-ASI video	270 Mbps	2R	—

Table 10-10 2R and 3R Mode and ITU-T G.709 Compliance by Client Interface (continued)

Client Interface	Input Bit Rate	3R vs. 2R	ITU-T G.709
ISC-1 Compat	1.06 Gbps	2R	Off
ISC-3	1.06 or 2.125 Gbps	2R	—
ETR_CLO	16 Mbps	2R	—

1. No monitoring

**Note**

ITU-T G.709 and FEC support is disabled for all the 2R payload types in the TXP_MR_2.5G and TXPP_MR_2.5G cards.

The output bit rate is calculated for the trunk bit rate by using the 255/238 ratio as specified in ITU-T G.709 for OTU1. [Table 10-11](#) lists the calculated trunk bit rates for the client interfaces with ITU-T G.709 enabled.

Table 10-11 Trunk Bit Rates With ITU-T G.709 Enabled

Client Interface	ITU-T G.709 Disabled	ITU-T G.709 Enabled
OC-48/STM-16	2.488 Gbps	2.66 Gbps
2G-FC	2.125 Gbps	2.27 Gbps
GE	1.25 Gbps	1.34 Gbps
1G-FC	1.06 Gbps	1.14 Gbps
OC-12/STM-3	622 Mbps	666.43 Mbps
OC-3/STM-1	155 Mbps	166.07 Mbps

For 2R operation mode, the TXP_MR_2.5G and TXPP_MR_2.5G cards have the ability to pass data through transparently from client side interfaces to a trunk side interface, which resides on an ITU grid. The data might vary at any bit rate from 200-Mbps up to 2.38-Gbps, including ESCON, DVB-ASI, ISC-1, and video signals. In this pass-through mode, no performance monitoring (PM) or digital wrapping of the incoming signal is provided, except for the usual PM outputs from the SFPs. Similarly, this card has the ability to pass data through transparently from the trunk side interfaces to the client side interfaces with bit rates varying from 200-Mbps up to 2.38-Gbps. Again, no PM or digital wrapping of received signals is available in this pass-through mode.

For 3R operation mode, the TXP_MR_2.5G and TXPP_MR_2.5G cards apply a digital wrapper to the incoming client interface signals (OC-N/STM-N, 1G-FC, 2G-FC, GE). PM is available on all of these signals except for 2G-FC, and varies depending upon the type of signal. For client inputs other than OC-48/STM-16, a digital wrapper might be applied but the resulting signal is not ITU-T G.709 compliant. The card applies a digital wrapper that is scaled to the frequency of the input signal.

The TXP_MR_2.5G and TXPP_MR_2.5G cards have the ability to take digitally wrapped signals in from the trunk interface, remove the digital wrapper, and send the unwrapped data through to the client interface. PM of the ITU-T G.709 OH and SONET/SDH OH is implemented.

10.6.1 Faceplate

Figure 10-16 shows the TXP_MR_2.5G and TXPP_MR_2.5G faceplates.

Figure 10-16 TXP_MR_2.5G and TXPP_MR_2.5G Faceplates

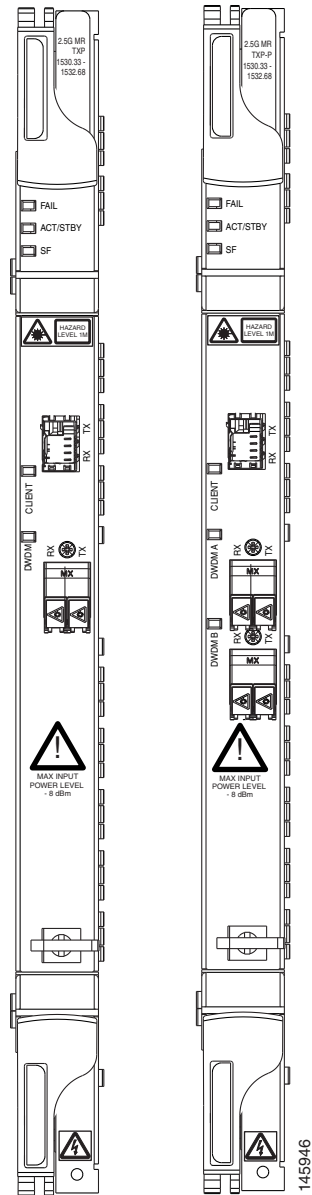

For information on safety labels for the cards, see the “10.2.2 Class 1M Laser Product Cards” section on page 10-11.

10.6.2 Block Diagram

Figure 10-17 shows a block diagram of the TXP_MR_2.5G and TXPP_MR_2.5G cards.

Figure 10-17 TXP_MR_2.5G and TXPP_MR_2.5G Block Diagram

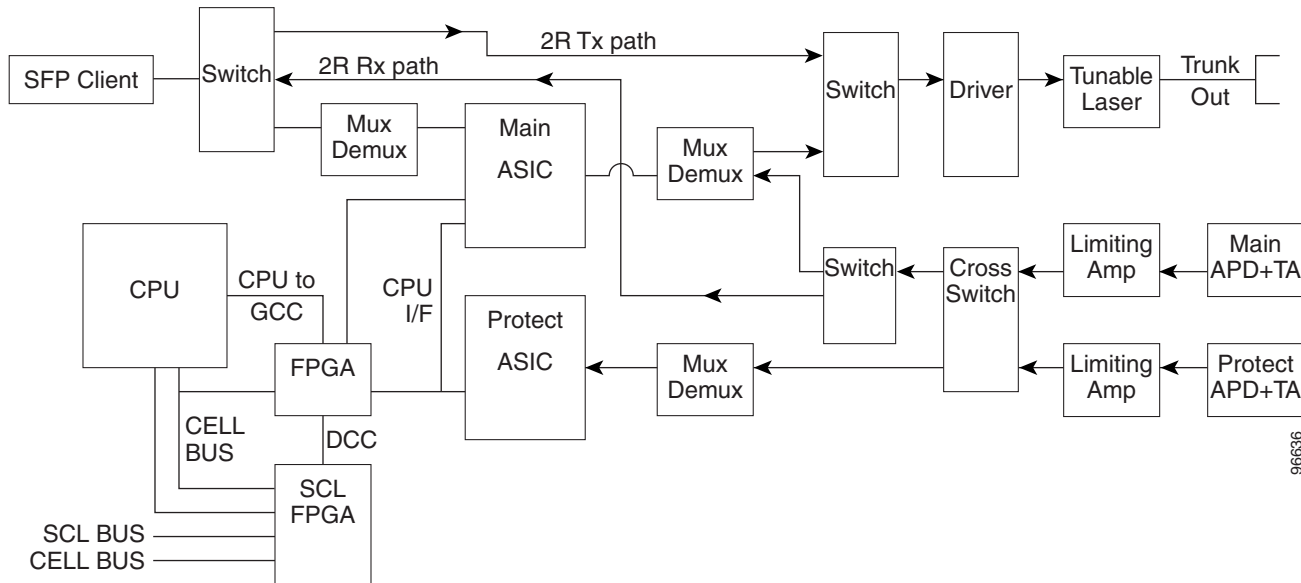
**Caution**

You must use a 20-dB fiber attenuator (15 to 25 dB) when working with the TXP_MR_2.5G and TXPP_MR_2.5G cards in a loopback on the trunk port. Do not use direct fiber loopbacks with the TXP_MR_2.5G and TXPP_MR_2.5G cards. Using direct fiber loopbacks causes irreparable damage to the TXP_MR_2.5G and TXPP_MR_2.5G cards.

You can install TXP_MR_2.5G and TXPP_MR_2.5G cards in Slots 1 to 6 and 12 to 17. You can provision this card in a linear configuration. TXP_MR_10G and TXPP_MR_2.5G cards cannot be provisioned as a BLSR/MS-SPRing, a path protection/SNCP, or a regenerator. They can be used in the middle of BLSR/MS-SPRing or 1+1 spans only when the card is configured for transparent termination mode.

The TXP_MR_2.5G card features a 1550-nm laser for the trunk/line port and a 1310-nm laser for the client port. It contains two transmit and receive connector pairs (labeled) on the card faceplate. The card uses dual LC connectors for optical cable termination.

The TXPP_MR_2.5G card features a 1550-nm laser for the trunk/line port and a 1310-nm or 850-nm laser (depending on the SFP) for the client port and contains three transmit and receive connector pairs (labeled) on the card faceplate. The card uses dual LC connectors for optical cable termination.

10.6.3 Automatic Laser Shutdown

The ALS procedure is supported on both client and trunk interfaces. On the client interface, ALS is compliant with ITU-T G.664 (6/99). On the data application and trunk interface, the switch on and off pulse duration is greater than 60 seconds. The on and off pulse duration is user-configurable. For details regarding ALS provisioning for the TXP_MR_2.5G and TXPP_MR_2.5G cards, refer to the *Cisco ONS 15454 DWDM Procedure Guide*.

10.6.4 TXP_MR_2.5G and TXPP_MR_2.5G Card-Level Indicators

Table 10-12 lists the three card-level LEDs on the TXP_MR_2.5G and TXPP_MR_2.5G cards.

Table 10-12 TXP_MR_2.5G and TXPP_MR_2.5G Card-Level Indicators

Card-Level LED	Description
Red FAIL LED	The red FAIL LED indicates that the card's processor is not ready. This LED is on during reset. The FAIL LED flashes during the boot process. Replace the card if the red FAIL LED persists.
ACT/STBY LED Green (Active) Amber (Standby)	If the ACT/STBY LED is green, the card is operational (one or both ports active) and ready to carry traffic. If the ACT/STBY LED is amber, the card is operational and in standby (protect) mode.
Amber SF LED	The amber SF LED indicates a signal failure or condition such as LOS, LOF, or high BERs on one or more of the card's ports. The amber SF LED is also on if the transmit and receive fibers are incorrectly connected. If the fibers are properly connected and the link is working, the light turns off.

10.6.5 TXP_MR_2.5G and TXPP_MR_2.5G Port-Level Indicators

Table 10-13 lists the four port-level LEDs on the TXP_MR_2.5G and TXPP_MR_2.5G cards.

Table 10-13 TXP_MR_2.5G and TXPP_MR_2.5G Port-Level Indicators

Port-Level LED	Description
Green Client LED	The green Client LED indicates that the client port is in service and that it is receiving a recognized signal.
Green DWDM LED (TXP_MR_2.5G only)	The green DWDM LED indicates that the DWDM port is in service and that it is receiving a recognized signal.
Green DWDM A LED (TXPP_MR_2.5G only)	The green DWDM A LED indicates that the DWDM A port is in service and that it is receiving a recognized signal.
Green DWDM B LED (TXPP_MR_2.5G only)	The green DWDM B LED indicates that the DWDM B port is in service and that it is receiving a recognized signal.

10.7 MXP_2.5G_10G Card

(Cisco ONS 15454 only)

The MXP_2.5G_10G card multiplexes/demultiplexes four 2.5-Gbps signals (client side) into one 10-Gbps, 100-GHz DWDM signal (trunk side). It provides one extended long-range STM-64/OC-192 port per card on the trunk side (compliant with ITU-T G.707, ITU-T G.709, ITU-T G.957, and Telcordia GR-253-CORE) and four intermediate- or short-range OC-48/STM-16 ports per card on the client side. The port operates at 9.95328 Gbps over unamplified distances up to 80 km (50 miles) with different types of fiber such as C-SMF or dispersion compensated fiber limited by loss and/or dispersion.

Client ports on the MXP_2.5G_10G card are also interoperable with SONET OC-1 (STS-1) fiber optic signals defined in Telcordia GR-253-CORE. An OC-1 signal is the equivalent of one DS-3 channel transmitted across optical fiber. OC-1 is primarily used for trunk interfaces to phone switches in the United States. There is no SDH equivalent for SONET OC-1.

The MXP_2.5G_10G card is tunable over two neighboring wavelengths in the 1550-nm, ITU 100-GHz range. It is available in 16 different versions, each of which covers two wavelengths, for a total coverage of 32 different wavelengths in the 1550-nm range.

**Note**

ITU-T G.709 specifies a form of FEC that uses a “wrapper” approach. The digital wrapper lets you transparently take in a signal on the client side, wrap a frame around it and restore it to its original form. FEC enables longer fiber links because errors caused by the optical signal degrading with distance are corrected.

The port can also operate at 10.70923 Gbps in ITU-T G.709 Digital Wrapper/FEC mode.

**Caution**

Because the transponder has no capability to look into the payload and detect circuits, an MXP_2.5G_10G card does not display circuits under card view.

**Caution**

You must use a 20-dB fiber attenuator (15 to 25 dB) when working with the MXP_2.5G_10G card in a loopback on the trunk port. Do not use direct fiber loopbacks with the MXP_2.5G_10G card. Using direct fiber loopbacks causes irreparable damage to the MXP_2.5G_10G card.

You can install MXP_2.5G_10G cards in Slots 1 to 6 and 12 to 17.

**Caution**

Do not install an MXP_2.5G_10G card in Slot 3 if you have installed a DS3/EC1-48 card in Slots 1 or 2. Likewise, do not install an MXP_2.5G_10G card in Slot 17 if you have installed a DS3/EC1-48 card in Slots 15 or 16. If you do, the cards will interact and cause DS-3 bit errors.

You can provision this card in a linear configuration. MXP_2.5G_10G cards cannot be provisioned as a BLSR/MS-SPRing, a path protection/SNCP, or a regenerator. They can be used in the middle of BLSR/MS-SPRing or 1+1 spans only when the card is configured for transparent termination mode.

The MXP_2.5G_10G port features a 1550-nm laser on the trunk port and four 1310-nm lasers on the client ports and contains five transmit and receive connector pairs (labeled) on the card faceplate. The card uses a dual LC connector on the trunk side and SFP connectors on the client side for optical cable termination.

**Note**

When you create a 4xOC-48 OCHCC circuit, you need to select the G.709 and Synchronous options. A 4xOC-48 OCHCC circuit is supported by G.709 and synchronous mode. This is necessary to provision a 4xOC-48 OCHCC circuit.

Figure 10-18 shows the MXP_2.5G_10G faceplate.

Figure 10-18 MXP_2.5G_10G Faceplate

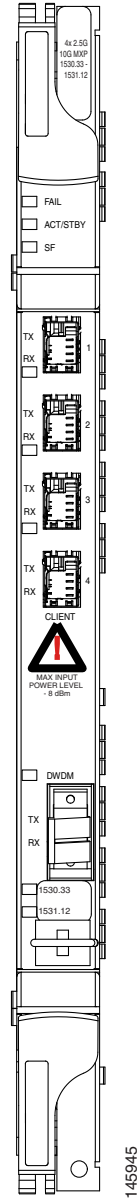

For information on safety labels for the card, see the “10.2.1 Class 1 Laser Product Cards” section on page 10-9.

Figure 10-19 shows a block diagram of the MXP_2.5G_10G card.

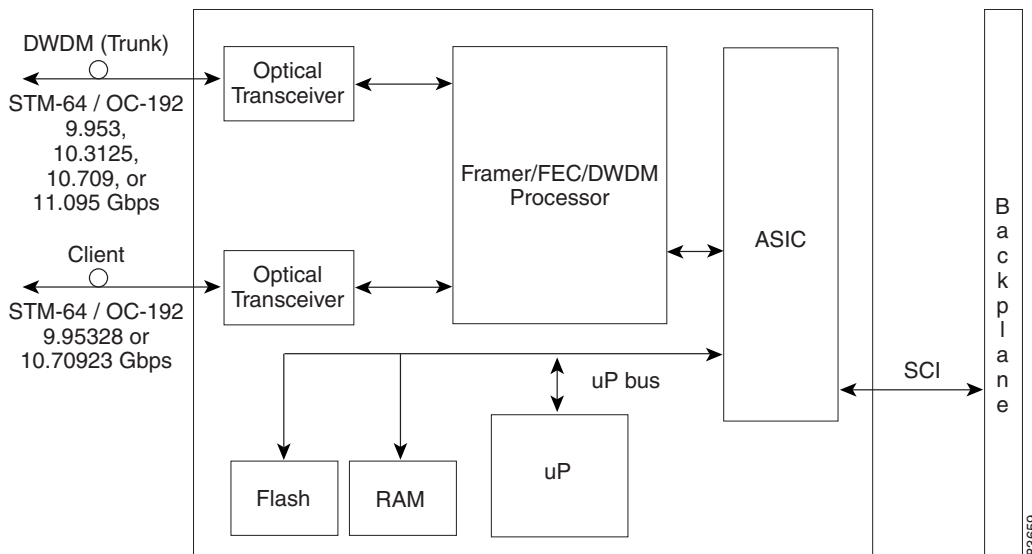
Figure 10-19 MXP_2.5G_10G Card Block Diagram

10.7.1 Timing Synchronization

The MXP_2.5G_10G card is synchronized to the TCC2/TCC2P/TCC3 clock during normal conditions and transmits the ITU-T G.709 frame using this clock. The TCC2/TCC2P/TCC3 card can operate from an external building integrated timing supply (BITS) clock, an internal Stratum 3 clock, or from clock recovered from one of the four valid client clocks. If clocks from both TCC2/TCC2P/TCC3 cards are not available, the MXP_2.5G_10G card switches automatically (with errors, not hitless) to an internal 19.44 MHz clock that does not meet SONET clock requirements. This will result in a clock alarm.

10.7.2 Automatic Laser Shutdown

The ALS procedure is supported on both client and trunk interfaces. On the client interface, ALS is compliant with ITU-T G.664 (6/99). On the data application and trunk interface, the switch on and off pulse duration is greater than 60 seconds. The on and off pulse duration is user-configurable. For details regarding ALS provisioning for the MXP_2.5G_10G card, refer to the *Cisco ONS 15454 DWDM Procedure Guide*.

10.7.3 MXP_2.5G_10G Card-Level Indicators

Table 10-14 describes the three card-level LEDs on the MXP_2.5G_10G card.

Table 10-14 MXP_2.5G_10G Card-Level Indicators

Card-Level LED	Description
Red FAIL LED	The red FAIL LED indicates that the card's processor is not ready. This LED is on during reset. The FAIL LED flashes during the boot process. Replace the card if the red FAIL LED persists.
ACT/STBY LED Green (Active) Amber (Standby)	If the ACT/STBY LED is green, the card is operational (one or more ports active) and ready to carry traffic. If the ACT/STBY LED is amber, the card is operational and in standby (protect) mode.
Amber SF LED	The amber SF LED indicates a signal failure or condition such as LOS, LOF, or high BERs on one or more of the card's ports. The amber SF LED is also on if the transmit and receive fibers are incorrectly connected. If the fibers are properly connected and the link is working, the light turns off.

10.7.3.1 MXP_2.5G_10G Port-Level Indicators

Table 10-15 describes the four port-level LEDs on the MXP_2.5G_10G card.

Table 10-15 MXP_2.5G_10G Port-Level Indicators

Port-Level LED	Description
Green Client LED (four LEDs)	The green Client LED indicates that the client port is in service and that it is receiving a recognized signal. The card has four client ports, and so has four Client LEDs.
Green DWDM LED	The green DWDM LED indicates that the DWDM port is in service and that it is receiving a recognized signal.
Green Wavelength 1 LED	Each port supports two wavelengths on the DWDM side. Each wavelength LED matches one of the wavelengths. This LED indicates that the card is configured for Wavelength 1.
Green Wavelength 2 LED	Each port supports two wavelengths on the DWDM side. Each wavelength LED matches one of the wavelengths. This LED indicates that the card is configured for Wavelength 2.

10.7.4 MXP_2.5G_10E Card

The faceplate designation of the card is "4x2.5G 10E MXP." The MXP_2.5G_10E card is a DWDM muxponder for the ONS 15454 platform that supports full transparent termination the client side. The card multiplexes four 2.5 Gbps client signals (4 x OC48/STM-16 SFP) into a single 10-Gbps DWDM optical signal on the trunk side. The MXP_2.5G_10E provides wavelength transmission service for the four incoming 2.5 Gbps client interfaces. The MXP_2.5G_10E muxponder passes all SONET/SDH overhead bytes transparently.

The digital wrapper function (ITU-T G.709 compliant) formats the DWDM wavelength so that it can be used to set up generic communications channels (GCCs) for data communications, enable FEC, or facilitate performance monitoring.

The MXP_2.5G_10E works with optical transport network (OTN) devices defined in ITU-T G.709. The card supports ODU1 to OTU2 multiplexing, an industry standard method for asynchronously mapping a SONET/SDH payload into a digitally wrapped envelope. See the “[10.7.7 Multiplexing Function](#)” section on page 10-36.

The MXP_2.5G_10E card is not compatible with the MXP_2.5G_10G card, which does not support full transparent termination. You can install MXP_2.5G_10E cards in Slots 1 to 6 and 12 to 17. You can provision this card in a linear configuration, as a BLSR/MS-SPRing, a path protection/SNCP, or a regenerator. The card can be used in the middle of BLSR/MS-SPRing or 1+1 spans when the card is configured for transparent termination mode.

The MXP_2.5G_10E features a 1550-nm laser on the trunk port and four 1310-nm lasers on the client ports and contains five transmit and receive connector pairs (labeled) on the card faceplate. The card uses a dual LC connector on the trunk side and uses SFP modules on the client side for optical cable termination. The SFP pluggable modules are short reach (SR) or intermediate reach (IR) and support an LC fiber connector.

**Note**

When you create a 4xOC-48 OCHCC circuit, you need to select the G.709 and Synchronous options. A 4xOC-48 OCHCC circuit is supported by G.709 and synchronous mode. This is necessary to provision a 4xOC-48 OCHCC circuit.

10.7.4.1 Key Features

The MXP_2.5G_10E card has the following high level features:

- Four 2.5 Gbps client interfaces (OC-48/STM-16) and one 10 Gbps trunk. The four OC-48 signals are mapped into a ITU-T G.709 OTU2 signal using standard ITU-T G.709 multiplexing.
- Onboard E-FEC processor: The processor supports both standard Reed-Solomon (RS, specified in ITU-T G.709) and E-FEC, which allows an improved gain on trunk interfaces with a resultant extension of the transmission range on these interfaces. The E-FEC functionality increases the correction capability of the transponder to improve performance, allowing operation at a lower OSNR compared to the standard RS (237,255) correction algorithm. A new block code (BCH) algorithm implemented in E-FEC allows recovery of an input BER up to 1E-3.
- Pluggable client interface optic modules: The MXP_2.5G_10E card has modular interfaces. Two types of optics modules can be plugged into the card. These include an OC-48/STM 16 SR-1 interface with a 7-km (4.3-mile) nominal range (for short range and intra-office applications) and an IR-1 interface with a range up to 40 km (24.9 miles). SR-1 is defined in Telcordia GR-253-CORE and in I-16 (ITU-T G.957). IR-1 is defined in Telcordia GR-253-CORE and in S-16-1 (ITU-T G.957).
- High level provisioning support: The MXP_2.5G_10E card is initially provisioned using Cisco TransportPlanner software. Subsequently, the card can be monitored and provisioned using CTC software.
- Link monitoring and management: The MXP_2.5G_10E card uses standard OC-48 OH (overhead) bytes to monitor and manage incoming interfaces. The card passes the incoming SDH/SONET data stream and its overhead bytes transparently.
- Control of layered SONET/SDH transport overhead: The card is provisionable to terminate regenerator section overhead. This is used to eliminate forwarding of unneeded layer overhead. It can help reduce the number of alarms and help isolate faults in the network.

- Automatic timing source synchronization: The MXP_2.5G_10E normally synchronizes from the TCC2/TCC2P/TCC3/TNC/TSC card. If for some reason, such as maintenance or upgrade activity, the TCC2/TCC2P/TCC3/TNC/TSC is not available, the MXP_2.5G_10E automatically synchronizes to one of the input client interface clocks.
- Configurable squelching policy: The card can be configured to squelch the client interface output if there is LOS at the DWDM receiver or if there is a remote fault. In the event of a remote fault, the card manages multiplex section alarm indication signal (MS-AIS) insertion.

10.7.5 Faceplate

Figure 10-20 shows the MXP_2.5G_10E faceplate.

Figure 10-20 MXP_2.5G_10E Faceplate

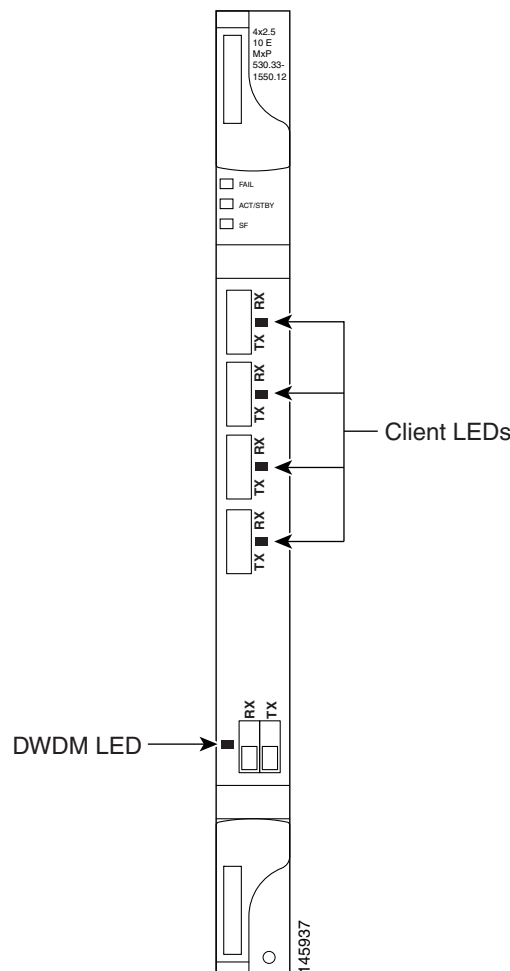

For information on safety labels for the card, see the “10.2.1 Class 1 Laser Product Cards” section on page 10-9.

Figure 10-21 shows a block diagram of the MXP_2.5G_10E card.

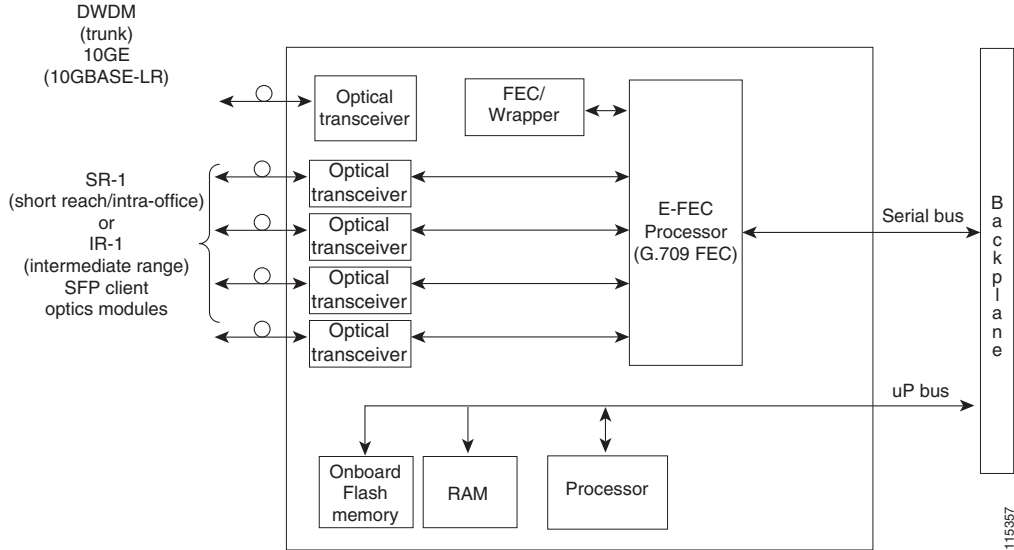
Figure 10-21 MXP_2.5G_10E Block Diagram

10.7.6 Client Interfaces

The MXP_2.5G_10E provides four intermediate- or short-range OC-48/STM-16 ports per card on the client side. Both SR-1 or IR-1 optics can be supported and the ports use SFP connectors. The client interfaces use four wavelengths in the 1310-nm, ITU 100-MHz-spaced, channel grid.

10.7.6.1 DWDM Interface

The MXP_2.5G_10E serves as an OTN multiplexer, transparently mapping four OC-48 channels asynchronously to ODU1 into one 10-Gbps trunk. The DWDM trunk is tunable for transmission over four wavelengths in the 1550-nm, ITU 100-GHz spaced channel grid.



Caution

You must use a 20-dB fiber attenuator (15 to 25 dB) when working with the MXP_2.5G_10E card in a loopback on the trunk port. Do not use direct fiber loopbacks with the MXP_2.5G_10E card. Using direct fiber loopbacks causes irreparable damage to the MXP_2.5G_10E card.

10.7.7 Multiplexing Function

The muxponder is an integral part of the reconfigurable optical add/drop multiplexer (ROADM) network. The key function of MXP_2.5G_10E is to multiplex 4 OC-48/STM16 signals onto one ITU-T G.709 OTU2 optical signal (DWDM transmission). The multiplexing mechanism allows the signal to be terminated at a far-end node by another MXP_2.5G_10E card.

Termination mode transparency on the muxponder is configured using OTUx and ODUx OH bytes. The ITU-T G.709 specification defines OH byte formats that are used to configure, set, and monitor frame alignment, FEC mode, section monitoring, tandem connection monitoring, and termination mode transparency.

The MXP_2.5G_10E card performs ODU to OTU multiplexing as defined in ITU-T G.709. The ODU is the framing structure and byte definition (ITU-T G.709 digital wrapper) used to define the data payload coming into one of the SONET/SDH client interfaces on MXP_2.5G_10E. The term ODU1 refers to an ODU that operates at 2.5-Gbps line rate. On the MXP_2.5G_10E, there are four client interfaces that can be defined using ODU1 framing structure and format by asserting a ITU-T G.709 digital wrapper.

The output of the muxponder is a single 10-Gbps DWDM trunk interface defined using OTU2. It is within the OTU2 framing structure that FEC or E-FEC information is appended to enable error checking and correction.

10.7.8 Timing Synchronization

The MXP_2.5G_10E card is synchronized to the TCC2/TCC2P/TCC3/TNC/TSC clock during normal conditions and transmits the ITU-T G.709 frame using this clock. No holdover function is implemented. If neither TCC2/TCC2P/TCC3/TNC/TSC clock is available, the MXP_2.5G_10E switches automatically (hitless) to the first of the four valid client clocks with no time restriction as to how long it can run on this clock. The MXP_2.5G_10E continues to monitor the TCC2/TCC2P/TCC3/TNC/TSC card. If a TCC2/TCC2P/TCC3/TNC/TSC card is restored to working order, the MXP_2.5G_10E reverts to the normal working mode of running from the TCC2/TCC2P/TCC3/TNC/TSC clock. If there is no valid TCC2/TCC2P/TCC3/TNC/TSC clock and all of the client channels become invalid, the card waits (no valid frames processed) until one of the TCC2/TCC2P/TCC3/TNC/TSC cards supplies a valid clock. In addition, the card is allowed to select the recovered clock from one active and valid client channel and supply that clock to the TCC2/TCC2P/TCC3/TNC/TSC card.

10.7.9 Enhanced FEC (E-FEC) Capability

The MXP_2.5G_10E can configure the FEC in three modes: NO FEC, FEC, and E-FEC. The output bit rate is always 10.7092 Gbps as defined in ITU-T G.709, but the error coding performance can be provisioned as follows:

- NO FEC—No FEC
- FEC—Standard ITU-T G.975 Reed-Solomon algorithm
- E-FEC—Standard ITU-T G.975.1 I.7, two orthogonally concatenated BCH super FEC code. This FEC scheme contains three parameterizations of the same scheme of two orthogonally interleaved BCH. The constructed code is decoded iteratively to achieve the expected performance.

10.7.10 FEC and E-FEC Modes

As client side traffic passes through the MXP_2.5G_10E card, it can be digitally wrapped using FEC mode error correction or E-FEC mode error correction (or no error correction at all). The FEC mode setting provides a lower level of error detection and correction than the E-FEC mode setting of the card. As a result, using E-FEC mode allows higher sensitivity (lower OSNR) with a lower BER than FEC mode. E-FEC enables longer distance trunk-side transmission than with FEC.

The E-FEC feature is one of three basic modes of FEC operation. FEC can be turned off, FEC can be turned on, or E-FEC can be turned on to provide greater range and lower BER. The default mode is FEC on and E-FEC off. E-FEC is provisioned using CTC.

10.7.11 SONET/SDH Overhead Byte Processing

The card passes the incoming SONET/SDH data stream and its overhead bytes for the client signal transparently. The card can be provisioned to terminate regenerator section overhead. This is used to eliminate forwarding of unneeded layer overhead. It can help reduce the number of alarms and help isolate faults in the network.

10.7.12 Client Interface Monitoring

The following parameters are monitored on the MXP_2.5G_10E card:

- Laser bias current is measured as a PM parameter
- LOS is detected and signaled
- Transmit (TX) and receive (RX) power are monitored

The following parameters are monitored in real time mode (one second):

- Optical power transmitted (client)
- Optical power received (client)

In case of loss of communication (LOC) at the DWDM receiver or far-end LOS, the client interface behavior is configurable. AIS can be invoked or the client signal can be squelched.

10.7.13 Wavelength Identification

The card uses trunk lasers that are wave-locked, which allows the trunk transmitter to operate on the ITU grid effectively. [Table 10-16](#) describes the required trunk transmit laser wavelengths. The laser is tunable over eight wavelengths at 50-GHz spacing or four at 100-GHz spacing.

Table 10-16 MXP_2.5G_10E Trunk Wavelengths

Band	Wavelength (nm)
30.3	1530.33
30.3	1531.12
30.3	1531.90
30.3	1532.68
34.2	1534.25
34.2	1535.04
34.2	1535.82
34.2	1536.61
38.1	1538.19
38.1	1538.98
38.1	1539.77
38.1	1540.56
42.1	1542.14
42.1	1542.94

Table 10-16 MXP_2.5G_10E Trunk Wavelengths (continued)

Band	Wavelength (nm)
42.1	1543.73
42.1	1544.53
46.1	1546.12
46.1	1546.92
46.1	1547.72
46.1	1548.51
50.1	1550.12
50.1	1550.92
50.1	1551.72
50.1	1552.52
54.1	1554.13
54.1	1554.94
54.1	1555.75
54.1	1556.55
58.1	1558.17
58.1	1558.98
58.1	1559.79
58.1	1560.61

10.7.14 Automatic Laser Shutdown

The ALS procedure is supported on both client and trunk interfaces. On the client interface, ALS is compliant with ITU-T G.664 (6/99). On the data application and trunk interface, the switch on and off pulse duration is greater than 60 seconds. The on and off pulse duration is user-configurable. For details regarding ALS provisioning for the MXP_2.5G_10E card, refer to the *Cisco ONS 15454 DWDM Procedure Guide*.

10.7.15 Jitter

For SONET and SDH signals, the MXP_2.5G_10E card complies with Telcordia GR-253-CORE, ITU-T G.825, and ITU-T G.873 for jitter generation, jitter tolerance, and jitter transfer. See the “[10.21 Jitter Considerations](#)” section on page 10-143 for more information.

10.7.16 Lamp Test

The MXP_2.5G_10E card supports a lamp test function that is activated from the ONS 15454 front panel or through CTC to ensure that all LEDs are functional.

10.7.17 Onboard Traffic Generation

The MXP_2.5G_10E card provides internal traffic generation for testing purposes according to pseudo-random bit sequence (PRBS), SONET/SDH, or ITU-T G.709.

10.7.18 MXP_2.5G_10E Card-Level Indicators

Table 10-17 describes the three card-level LEDs on the MXP_2.5G_10E card.

Table 10-17 MXP_2.5G_10E Card-Level Indicators

Card-Level LED	Description
Red FAIL LED	The red FAIL LED indicates that the card's processor is not ready. This LED is on during reset. The FAIL LED flashes during the boot process. Replace the card if the red FAIL LED persists.
ACT/STBY LED Green (Active) Amber (Standby)	If the ACT/STBY LED is green, the card is operational (one or more ports active) and ready to carry traffic. If the ACT/STBY LED is amber, the card is operational and in standby (protect) mode.
Amber SF LED	The amber SF LED indicates a signal failure or condition such as LOS, LOF, or high BERs on one or more of the card's ports. The amber SF LED is also on if the transmit and receive fibers are incorrectly connected. If the fibers are properly connected and the link is working, the light turns off.

10.7.19 MXP_2.5G_10E Port-Level Indicators

Table 10-18 describes the port-level LEDs on the MXP_2.5G_10E card.

Table 10-18 MXP_2.5G_10E Port-Level Indicators

Port-Level LED	Description
Green Client LED (four LEDs)	A green Client LED indicates that the client port is in service and that it is receiving a recognized signal. The card has four client ports, and so has four Client LEDs.
Green DWDM LED	The green DWDM LED indicates that the DWDM port is in service and that it is receiving a recognized signal.

10.8 MXP_2.5G_10E_C and MXP_2.5G_10E_L Cards

MXP_2.5G_10E_L: (Cisco ONS 15454 only)

The MXP_2.5G_10E_C and MXP_2.5G_10E_L cards are DWDM muxponders for the ONS 15454 platform that support transparent termination mode on the client side. The faceplate designation of the cards is "4x2.5G 10E MXP C" for the MXP_2.5G_10E_C card and "4x2.5G 10E MXP L" for the MXP_2.5G_10E_L card. The cards multiplex four 2.5-Gbps client signals (4 x OC48/STM-16 SFP) into a single 10-Gbps DWDM optical signal on the trunk side. The MXP_2.5G_10E_C and

MXP_2.5G_10E_L cards provide wavelength transmission service for the four incoming 2.5 Gbps client interfaces. The MXP_2.5G_10E_C and MXP_2.5G_10E_L muxponders pass all SONET/SDH overhead bytes transparently.

The digital wrapper function (ITU-T G.709 compliant) formats the DWDM wavelength so that it can be used to set up GCCs for data communications, enable FEC, or facilitate PM.

The MXP_2.5G_10E_C and MXP_2.5G_10E_L cards work with OTN devices defined in ITU-T G.709. The cards support ODU1 to OTU2 multiplexing, an industry standard method for asynchronously mapping a SONET/SDH payload into a digitally wrapped envelope. See the “[10.8.5 Multiplexing Function](#)” section on page 10-44.

The MXP_2.5G_10E_C and MXP_2.5G_10E_L cards are not compatible with the MXP_2.5G_10G card, which does not support transparent termination mode.

You can install MXP_2.5G_10E_C and MXP_2.5G_10E_L cards in Slots 1 to 6 and 12 to 17. You can provision a card in a linear configuration, as a BLSR/MS-SPRing, a path protection/SNCP, or a regenerator. The cards can be used in the middle of BLSR/MS-SPRing or 1+1 spans when the cards are configured for transparent termination mode.

The MXP_2.5G_10E_C card features a tunable 1550-nm C-band laser on the trunk port. The laser is tunable across 82 wavelengths on the ITU grid with 50-GHz spacing between wavelengths. The MXP_2.5G_10E_L features a tunable 1580-nm L-band laser on the trunk port. The laser is tunable across 80 wavelengths on the ITU grid, also with 50-GHz spacing. Each card features four 1310-nm lasers on the client ports and contains five transmit and receive connector pairs (labeled) on the card faceplate. The cards use dual LC connectors on the trunk side and use SFP modules on the client side for optical cable termination. The SFP pluggable modules are SR or IR and support an LC fiber connector.

Note

When you create a 4xOC-48 OCHCC circuit, you need to select the G.709 and Synchronous options. A 4xOC-48 OCHCC circuit is supported by G.709 and synchronous mode. This is necessary to provision a 4xOC-48 OCHCC circuit.

10.8.1 Key Features

The MXP_2.5G_10E_C and MXP_2.5G_10E_L cards have the following high level features:

- Four 2.5 Gbps client interfaces (OC-48/STM-16) and one 10 Gbps trunk. The four OC-48 signals are mapped into a ITU-T G.709 OTU2 signal using standard ITU-T G.709 multiplexing.
- Onboard E-FEC processor: The processor supports both standard RS (specified in ITU-T G.709) and E-FEC, which allows an improved gain on trunk interfaces with a resultant extension of the transmission range on these interfaces. The E-FEC functionality increases the correction capability of the transponder to improve performance, allowing operation at a lower OSNR compared to the standard RS (237,255) correction algorithm. A new BCH algorithm implemented in E-FEC allows recovery of an input BER up to 1E-3.
- Pluggable client interface optic modules: The MXP_2.5G_10E_C and MXP_2.5G_10E_L cards have modular interfaces. Two types of optics modules can be plugged into the card. These include an OC-48/STM 16 SR-1 interface with a 7-km (4.3-mile) nominal range (for short range and intra-office applications) and an IR-1 interface with a range up to 40 km (24.9 miles). SR-1 is defined in Telcordia GR-253-CORE and in I-16 (ITU-T G.957). IR-1 is defined in Telcordia GR-253-CORE and in S-16-1 (ITU-T G.957).
- High level provisioning support: The cards are initially provisioned using Cisco TransportPlanner software. Subsequently, the card can be monitored and provisioned using CTC software.

- Link monitoring and management: The cards use standard OC-48 OH (overhead) bytes to monitor and manage incoming interfaces. The cards pass the incoming SDH/SONET data stream and its overhead bytes transparently.
- Control of layered SONET/SDH transport overhead: The cards are provisionable to terminate regenerator section overhead. This is used to eliminate forwarding of unneeded layer overhead. It can help reduce the number of alarms and help isolate faults in the network.
- Automatic timing source synchronization: The MXP_2.5G_10E_C and MXP_2.5G_10E_L cards normally synchronize from the TCC2/TCC2P/TCC3 card. If for some reason, such as maintenance or upgrade activity, the TCC2/TCC2P/TCC3 is not available, the cards automatically synchronize to one of the input client interface clocks.
- Configurable squelching policy: The cards can be configured to squelch the client interface output if there is LOS at the DWDM receiver or if there is a remote fault. In the event of a remote fault, the card manages MS-AIS insertion.
- The cards are tunable across the full C band (MXP_2.5G_10E_C) or full L band (MXP_2.5G_10E_L), thus eliminating the need to use different versions of each card to provide tunability across specific wavelengths in a band.

10.8.2 Faceplate

Figure 10-22 shows the MXP_2.5G_10E_C and MXP_2.5G_10E_L faceplates and block diagram.

Figure 10-22 MXP_2.5G_10E_C and MXP_2.5G_10E_L Faceplates and Block Diagram

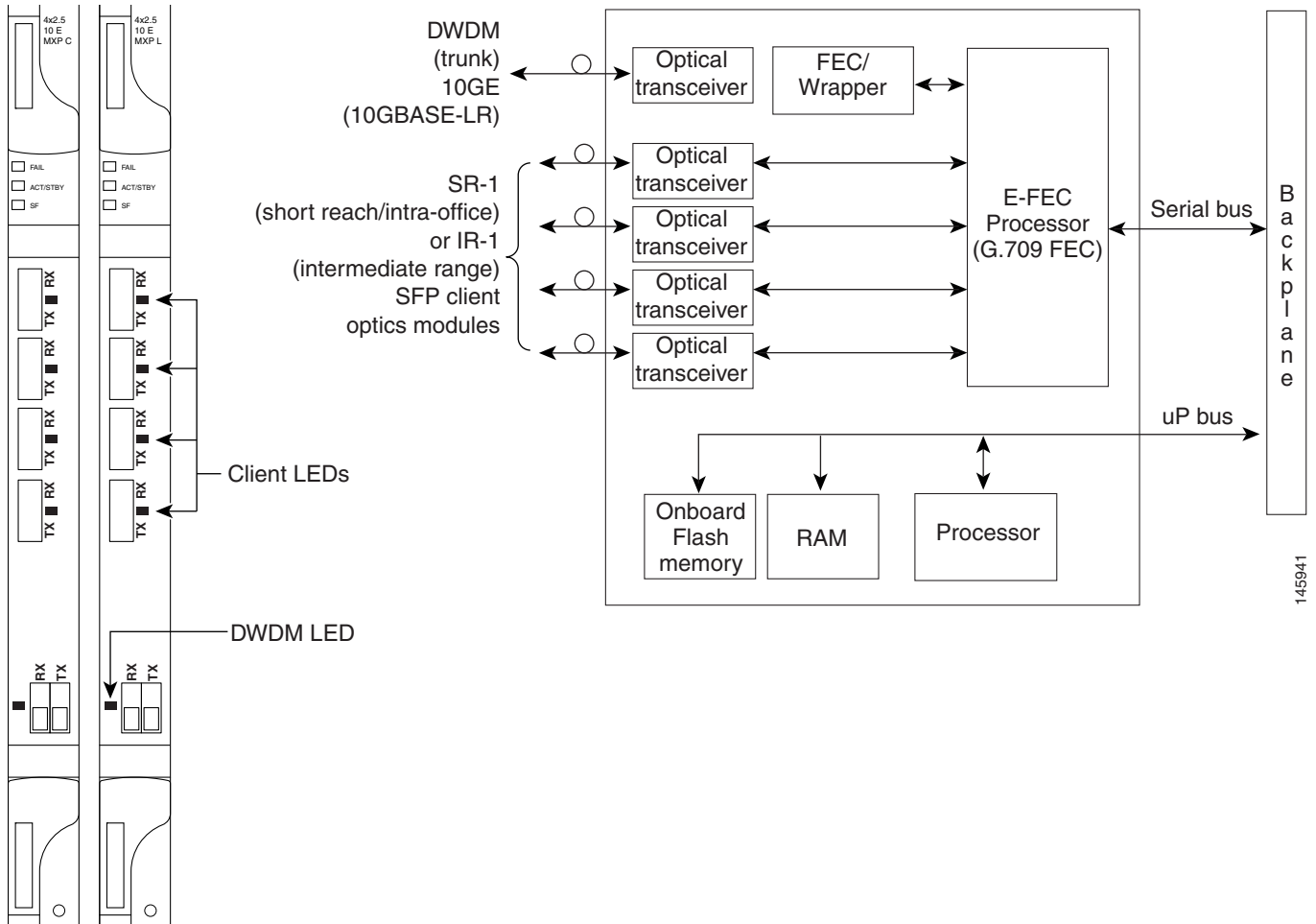

For information on safety labels for the cards, see the “10.2.1 Class 1 Laser Product Cards” section on page 10-9.

10.8.3 Client Interfaces

The MXP_2.5G_10E_C and MXP_2.5G_10E_L cards provide four intermediate- or short-range OC-48/STM-16 ports per card on the client side. Both SR-1 and IR-1 optics can be supported and the ports use SFP connectors. The client interfaces use four wavelengths in the 1310-nm, ITU 100-GHz-spaced, channel grid.

10.8.4 DWDM Interface

The MXP_2.5G_10E_C and MXP_2.5G_10E_L cards serve as OTN multiplexers, transparently mapping four OC-48 channels asynchronously to ODU1 into one 10-Gbps trunk. For the MXP_2.5G_10E_C card, the DWDM trunk is tunable for transmission over the entire C band and for the MXP_2.5G_10E_L card, the DWDM trunk is tunable for transmission over the entire L band. Channels are spaced at 50-GHz on the ITU grid.

**Caution**

You must use a 20-dB fiber attenuator (15 to 25 dB) when working with the cards in a loopback on the trunk port. Do not use direct fiber loopbacks with the cards. Using direct fiber loopbacks causes irreparable damage to the MXP_2.5G_10E_C and MXP_2.5G_10E_L cards.

10.8.5 Multiplexing Function

The muxponder is an integral part of the ROADM network. The key function of the MXP_2.5G_10E_C and MXP_2.5G_10E_L cards is to multiplex four OC-48/STM16 signals onto one ITU-T G.709 OTU2 optical signal (DWDM transmission). The multiplexing mechanism allows the signal to be terminated at a far-end node by another similar card.

Transparent termination on the muxponder is configured using OTUx and ODUx OH bytes. The ITU-T G.709 specification defines OH byte formats that are used to configure, set, and monitor frame alignment, FEC mode, section monitoring, tandem connection monitoring, and transparent termination mode.

The MXP_2.5G_10E and MXP_2.5G_10E_L cards perform ODU to OTU multiplexing as defined in ITU-T G.709. The ODU is the framing structure and byte definition (ITU-T G.709 digital wrapper) used to define the data payload coming into one of the SONET/SDH client interfaces on the cards. The term ODU1 refers to an ODU that operates at 2.5-Gbps line rate. On the cards, there are four client interfaces that can be defined using ODU1 framing structure and format by asserting a ITU-T G.709 digital wrapper.

The output of the muxponder is a single 10-Gbps DWDM trunk interface defined using OTU2. It is within the OTU2 framing structure that FEC or E-FEC information is appended to enable error checking and correction.

10.8.6 Timing Synchronization

The MXP_2.5G_10E_C and MXP_2.5G_10E_L cards are synchronized to the TCC2/TCC2P/TCC3 clock during normal conditions and transmit the ITU-T G.709 frame using this clock. No holdover function is implemented. If neither TCC2/TCC2P/TCC3 clock is available, the card switches automatically (hitless) to the first of the four valid client clocks with no time restriction as to how long it can run on this clock. The card continues to monitor the TCC2/TCC2P/TCC3 card. If a TCC2/TCC2P/TCC3 card is restored to working order, the card reverts to the normal working mode of running from the TCC2/TCC2P/TCC3 clock. If there is no valid TCC2/TCC2P/TCC3 clock and all of the client channels become invalid, the card waits (no valid frames processed) until one of the TCC2/TCC2P/TCC3 cards supplies a valid clock. In addition, the card is allowed to select the recovered clock from one active and valid client channel and supply that clock to the TCC2/TCC2P/TCC3 card.

10.8.7 Enhanced FEC (E-FEC) Capability

The MXP_2.5G_10E_C and MXP_2.5G_10E_L cards can configure the FEC in three modes: NO FEC, FEC, and E-FEC. The output bit rate is always 10.7092 Gbps as defined in ITU-T G.709, but the error coding performance can be provisioned as follows:

- NO FEC—No FEC
- FEC—Standard ITU-T G.975 Reed-Solomon algorithm

- E-FEC—Standard ITU-T G.975.1 I.7, two orthogonally concatenated BCH super FEC code. This FEC scheme contains three parameterizations of the same scheme of two orthogonally interleaved block codes (BCH). The constructed code is decoded iteratively to achieve the expected performance.

10.8.8 FEC and E-FEC Modes

As client side traffic passes through the card, it can be digitally wrapped using FEC mode error correction or E-FEC mode error correction (or no error correction at all). The FEC mode setting provides a lower level of error detection and correction than the E-FEC mode setting of the card. As a result, using E-FEC mode allows higher sensitivity (lower OSNR) with a lower BER than FEC mode. E-FEC enables longer distance trunk-side transmission than with FEC.

The E-FEC feature is one of three basic modes of FEC operation. FEC can be turned off, FEC can be turned on, or E-FEC can be turned on to provide greater range and lower BER. The default mode is FEC on and E-FEC off. E-FEC is provisioned using CTC.

10.8.9 SONET/SDH Overhead Byte Processing

The card passes the incoming SONET/SDH data stream and its overhead bytes for the client signal transparently. The card can be provisioned to terminate regenerator section overhead. This is used to eliminate forwarding of unneeded layer overhead. It can help reduce the number of alarms and help isolate faults in the network.

10.8.10 Client Interface Monitoring

The following parameters are monitored on the MXP_2.5G_10E_C and MXP_2.5G_10E_L cards:

- Laser bias current is measured as a PM parameter.
- LOS is detected and signaled.
- Rx and Tx power are monitored.

The following parameters are monitored in real time mode (one second):

- Optical power transmitted (client)
- Optical power received (client)

In case of LOC at the DWDM receiver or far-end LOS, the client interface behavior is configurable. AIS can be invoked or the client signal can be squelched.

10.8.11 Wavelength Identification

The card uses trunk lasers that are wavelocked, which allows the trunk transmitter to operate on the ITU grid effectively. Both the MXP_2.5G_10E_C and MXP_2.5G_10E_L cards implement the UT2 module. The MXP_2.5G_10E_C card uses a C-band version of the UT2 and the MXP_2.5G_10E_L card uses an L-band version.

[Table 10-19](#) describes the required trunk transmit laser wavelengths for the MXP_2.5G_10E_C card. The laser is tunable over 82 wavelengths in the C band at 50-GHz spacing on the ITU grid.

Table 10-19 MXP_2.5G_10E_C Trunk Wavelengths

Channel Number	Frequency (THz)	Wavelength (nm)	Channel Number	Frequency (THz)	Wavelength (nm)
1	196.00	1529.55	42	193.95	1545.72
2	195.95	1529.94	43	193.90	1546.119
3	195.90	1530.334	44	193.85	1546.518
4	195.85	1530.725	45	193.80	1546.917
5	195.80	1531.116	46	193.75	1547.316
6	195.75	1531.507	47	193.70	1547.715
7	195.70	1531.898	48	193.65	1548.115
8	195.65	1532.290	49	193.60	1548.515
9	195.60	1532.681	50	193.55	1548.915
10	195.55	1533.073	51	193.50	1549.32
11	195.50	1533.47	52	193.45	1549.71
12	195.45	1533.86	53	193.40	1550.116
13	195.40	1534.250	54	193.35	1550.517
14	195.35	1534.643	55	193.30	1550.918
15	195.30	1535.036	56	193.25	1551.319
16	195.25	1535.429	57	193.20	1551.721
17	195.20	1535.822	58	193.15	1552.122
18	195.15	1536.216	59	193.10	1552.524
19	195.10	1536.609	60	193.05	1552.926
20	195.05	1537.003	61	193.00	1553.33
21	195.00	1537.40	62	192.95	1553.73
22	194.95	1537.79	63	192.90	1554.134
23	194.90	1538.186	64	192.85	1554.537
24	194.85	1538.581	65	192.80	1554.940
25	194.80	1538.976	66	192.75	1555.343
26	194.75	1539.371	67	192.70	1555.747
27	194.70	1539.766	68	192.65	1556.151
28	194.65	1540.162	69	192.60	1556.555
29	194.60	1540.557	70	192.55	1556.959
30	194.55	1540.953	71	192.50	1557.36
31	194.50	1541.35	72	192.45	1557.77
32	194.45	1541.75	73	192.40	1558.173
33	194.40	1542.142	74	192.35	1558.578
34	194.35	1542.539	75	192.30	1558.983
35	194.30	1542.936	76	192.25	1559.389

Table 10-19 MXP_2.5G_10E_C Trunk Wavelengths (continued)

Channel Number	Frequency (THz)	Wavelength (nm)	Channel Number	Frequency (THz)	Wavelength (nm)
36	194.25	1543.333	77	192.20	1559.794
37	194.20	1543.730	78	192.15	1560.200
38	194.15	1544.128	79	192.10	1560.606
39	194.10	1544.526	80	192.05	1561.013
40	194.05	1544.924	81	192.00	1561.42
41	194.00	1545.32	82	191.95	1561.83

Table 10-20 describes the required trunk transmit laser wavelengths for the MXP_2.5G_10E_L card. The laser is fully tunable over 80 wavelengths in the L band at 50-GHz spacing on the ITU grid.

Table 10-20 MXP_2.5G_10E_L Trunk Wavelengths

Channel Number	Frequency (THz)	Wavelength (nm)	Channel Number	Frequency (THz)	Wavelength (nm)
1	190.85	1570.83	41	188.85	1587.46
2	190.8	1571.24	42	188.8	1587.88
3	190.75	1571.65	43	188.75	1588.30
4	190.7	1572.06	44	188.7	1588.73
5	190.65	1572.48	45	188.65	1589.15
6	190.6	1572.89	46	188.6	1589.57
7	190.55	1573.30	47	188.55	1589.99
8	190.5	1573.71	48	188.5	1590.41
9	190.45	1574.13	49	188.45	1590.83
10	190.4	1574.54	50	188.4	1591.26
11	190.35	1574.95	51	188.35	1591.68
12	190.3	1575.37	52	188.3	1592.10
13	190.25	1575.78	53	188.25	1592.52
14	190.2	1576.20	54	188.2	1592.95
15	190.15	1576.61	55	188.15	1593.37
16	190.1	1577.03	56	188.1	1593.79
17	190.05	1577.44	57	188.05	1594.22
18	190	1577.86	58	188	1594.64
19	189.95	1578.27	59	187.95	1595.06
20	189.9	1578.69	60	187.9	1595.49
21	189.85	1579.10	61	187.85	1595.91
22	189.8	1579.52	62	187.8	1596.34
23	189.75	1579.93	63	187.75	1596.76

Table 10-20 MXP_2.5G_10E_L Trunk Wavelengths (continued)

Channel Number	Frequency (THz)	Wavelength (nm)	Channel Number	Frequency (THz)	Wavelength (nm)
24	189.7	1580.35	64	187.7	1597.19
25	189.65	1580.77	65	187.65	1597.62
26	189.6	1581.18	66	187.6	1598.04
27	189.55	1581.60	67	187.55	1598.47
28	189.5	1582.02	68	187.5	1598.89
29	189.45	1582.44	69	187.45	1599.32
30	189.4	1582.85	70	187.4	1599.75
31	189.35	1583.27	71	187.35	1600.17
32	189.3	1583.69	72	187.3	1600.60
33	189.25	1584.11	73	187.25	1601.03
34	189.2	1584.53	74	187.2	1601.46
35	189.15	1584.95	75	187.15	1601.88
36	189.1	1585.36	76	187.1	1602.31
37	189.05	1585.78	77	187.05	1602.74
38	189	1586.20	78	187	1603.17
39	188.95	1586.62	79	186.95	1603.60
40	188.9	1587.04	80	186.9	1604.03

10.8.12 Automatic Laser Shutdown

The ALS procedure is supported on both client and trunk interfaces. On the client interface, ALS is compliant with ITU-T G.664 (6/99). On the data application and trunk interface, the switch on and off pulse duration is greater than 60 seconds. The on and off pulse duration is user-configurable. For details regarding ALS provisioning for the MXP_2.5G_10E_C and MXP_2.5G_10E_L cards, see the *Cisco ONS 15454 DWDM Procedure Guide*.

10.8.13 Jitter

For SONET and SDH signals, the MXP_2.5G_10E_C and MXP_2.5G_10E_L cards comply with Telcordia GR-253-CORE, ITU-T G.825, and ITU-T G.873 for jitter generation, jitter tolerance, and jitter transfer. See the “[10.21 Jitter Considerations](#)” section on page 10-143 for more information.

10.8.14 Lamp Test

The MXP_2.5G_10E_C and MXP_2.5G_10E_L cards support a lamp test function that is activated from the ONS 15454 front panel or through CTC to ensure that all LEDs are functional.

10.8.15 Onboard Traffic Generation

The MXP_2.5G_10E_C and MXP_2.5G_10E_L cards provide internal traffic generation for testing purposes according to PRBS, SONET/SDH, or ITU-T G.709.

10.8.16 MXP_2.5G_10E_C and MXP_2.5G_10E_L Card-Level Indicators

Table 10-21 describes the three card-level LEDs on the MXP_2.5G_10E_C and MXP_2.5G_10E_L cards.

Table 10-21 MXP_2.5G_10E_C and MXP_2.5G_10E_L Card-Level Indicators

Card-Level LED	Description
Red FAIL LED	The red FAIL LED indicates that the card's processor is not ready. This LED is on during reset. The FAIL LED flashes during the boot process. Replace the card if the red FAIL LED persists.
ACT/STBY LED Green (Active) Amber (Standby)	If the ACT/STBY LED is green, the card is operational (one or more ports active) and ready to carry traffic. If the ACT/STBY LED is amber, the card is operational and in standby (protect) mode.
Amber SF LED	The amber SF LED indicates a signal failure or condition such as LOS, LOF, or high BERs on one or more of the card's ports. The amber SF LED is also on if the transmit and receive fibers are incorrectly connected. If the fibers are properly connected and the link is working, the light turns off.

10.8.17 MXP_2.5G_10E and MXP_2.5G_10E_L Port-Level Indicators

Table 10-22 describes the port-level LEDs on the MXP_2.5G_10E_C and MXP_2.5G_10E_L cards.

Table 10-22 MXP_2.5G_10E_C and MXP_2.5G_10E_L Port-Level Indicators

Port-Level LED	Description
Green Client LED (four LEDs)	A green Client LED indicates that the client port is in service and that it is receiving a recognized signal. The card has four client ports, and so has four Client LEDs.
Green DWDM LED	The green DWDM LED indicates that the DWDM port is in service and that it is receiving a recognized signal.

10.9 MXP_MR_2.5G and MXPP_MR_2.5G Cards

The MXP_MR_2.5G card aggregates a mix and match of client Storage Area Network (SAN) service client inputs (GE, FICON, Fibre Channel, and ESCON) into one 2.5 Gbps STM-16/OC-48 DWDM signal on the trunk side. It provides one long-reach STM-16/OC-48 port per card and is compliant with Telcordia GR-253-CORE.

**Note**

In Software Release 7.0 and later, two additional operating modes have been made available to the user: pure ESCON (all 8 ports running ESCON), and mixed mode (Port 1 running FC/GE/FICON, and Ports 5 through 8 running ESCON). When the card is part of a system running Software Release 6.0 or below, only one operating mode, (FC/GE) is available for use.

The 2.5-Gbps Multirate Muxponder–Protected–100 GHz–Tunable 15xx.xx-15yy.yy (MXPP_MR_2.5G) card aggregates various client SAN service client inputs (GE, FICON, Fibre Channel, and ESCON) into one 2.5 Gbps STM-16/OC-48 DWDM signal on the trunk side. It provides two long-reach STM-16/OC-48 ports per card and is compliant with ITU-T G.957 and Telcordia GR-253-CORE.

Because the cards are tunable to one of four adjacent grid channels on a 100-GHz spacing, each card is available in eight versions, with 15xx.xx representing the first wavelength and 15yy.yy representing the last wavelength of the four available on the card. In total, 32 DWDM wavelengths are covered in accordance with the ITU-T 100-GHz grid standard, G.692, and Telcordia GR-2918-CORE, Issue 2. The card versions along with their corresponding wavelengths are shown in [Table 10-23](#).

Table 10-23 Card Versions

Card Version	Frequency Channels at 100 GHz (0.8 nm) Spacing			
1530.33–1532.68	1530.33 nm	1531.12 nm	1531.90 nm	1532.68 nm
1534.25–1536.61	1534.25 nm	1535.04 nm	1535.82 nm	1536.61 nm
1538.19–1540.56	1538.19 nm	1538.98 nm	1539.77 nm	1540.56 nm
1542.14–1544.53	1542.14 nm	1542.94 nm	1543.73 nm	1544.53 nm
1546.12–1548.51	1546.12 nm	1546.92 nm	1547.72 nm	1548.51 nm
1550.12–1552.52	1550.12 nm	1550.92 nm	1551.72 nm	1552.52 nm
1554.13–1556.55	1554.13 nm	1554.94 nm	1555.75 nm	1556.55 nm
1558.17–1560.61	1558.17 nm	1558.98 nm	1559.79 nm	1560.61 nm

The muxponders are intended to be used in applications with long DWDM metro or regional unregenerated spans. Long transmission distances are achieved through the use of flat gain optical amplifiers.

The client interface supports the following payload types:

- 2G FC
- 1G FC
- 2G FICON
- 1G FICON
- GE
- ESCON

**Note**

Because the client payload cannot oversubscribe the trunk, a mix of client signals can be accepted, up to a maximum limit of 2.5 Gbps.

Table 10-24 shows the input data rate for each client interface, and the encapsulation method. The current version of the ITU-T Transparent Generic Framing Procedure (GFP-T) G.7041 supports transparent mapping of 8B/10B block-coded protocols, including Gigabit Ethernet, Fibre Channel, and FICON.

In addition to the GFP mapping, 1-Gbps traffic on Port 1 or 2 of the high-speed serializer/deserializer (SERDES) is mapped to an STS-24c channel. If two 1-Gbps client signals are present at Port 1 and Port 2 of the SERDES, the Port 1 signal is mapped into the first STS-24c channel and the Port 2 signal into the second STS-24c channel. The two channels are then mapped into an OC-48 trunk channel.

Table 10-24 MXP_MR_2.5G and MXPP_MR_2.5G Client Interface Data Rates and Encapsulation

Client Interface	Input Data Rate	ITU-T GFP-T G.7041 Encapsulation
2G FC	2.125 Gbps	Yes
1G FC	1.06 Gbps	Yes
2G FICON	2.125 Gbps	Yes
1G FICON	1.06 Gbps	Yes
GE	1.25 Gbps	Yes
ESCON	0.2 Gbps	Yes

Table 10-25 shows some of the mix and match possibilities on the various client ports. The table is intended to show the full client payload configurations for the card.

Table 10-25 Client Data Rates and Ports

Mode	Port(s)	Aggregate Data Rate
2G FC	1	2.125 Gbps
1G FC	1, 2	2.125 Gbps
2G FICON	1	2.125 Gbps
1G FICON	1, 2	2.125 Gbps
GE	1, 2	2.5 Gbps
1G FC ESCON (mixed mode)	1 5, 6, 7, 8	1.06 Gbps 0.8 Gbps 1.86 Gbps total
1G FICON ESCON (mixed mode)	1 5, 6, 7, 8	1.06 Gbps 0.8 Gbps 1.86 Gbps total
GE ESCON (mixed mode)	1 5, 6, 7, 8	1.25 Gbps 0.8 Gbps Total 2.05 Gbps
ESCON	1, 2, 3, 4, 5, 6, 7, 8	1.6 Gbps

10.9.1 Performance Monitoring

GFP-T performance monitoring (GFP-T PM) is available via remote monitoring (RMON), and trunk PM is managed according to Telcordia GR-253-CORE and ITU G.783/826. Client PM is achieved through RMON for FC and GE.

10.9.2 Distance Extension

A buffer-to-buffer credit management scheme provides FC flow control. With this feature enabled, a port indicates the number of frames that can be sent to it (its buffer credit), before the sender is required to stop transmitting and wait for the receipt of a “ready” indication. The MXP_MR_2.5G and MXPP_MR_2.5 cards support FC credit-based flow control with a buffer-to-buffer credit extension of up to 1600 km (994.2 miles) for 1G FC and up to 800 km (497.1 miles) for 2G FC. The feature can be enabled or disabled.

10.9.3 Slot Compatibility

You can install MXP_MR_2.5G and MXPP_MR_2.5G cards in Slots 1 to 6 and 12 to 17. The TCC2/TCC2P/TCC3/TNC/TSC card is the only other card required to be used with these muxponder cards. Cross-connect cards do not affect the operation of the muxponder cards.

10.9.4 Interoperability with Cisco MDS Switches

You can provision a string (port name) for each fiber channel/FICON interface on the MXP_MR_2.5G and MXPP_MR_2.5G cards, which allows the MDS Fabric Manager to create a link association between that SAN port and a SAN port on a Cisco MDS 9000 switch.

10.9.5 Client and Trunk Ports

The MXP_MR_2.5G card features a 1550-nm laser for the trunk/line port and a 1310-nm or 850-nm laser (depending on the SFP) for the client ports. The card contains eight 12.5 degree downward tilt SFP modules for the client interfaces. For optical termination, each SFP uses two LC connectors, which are labeled TX and RX on the faceplate. The trunk port is a dual-LC connector with a 45 degree downward angle.

The MXPP_MR_2.5G card features a 1550-nm laser for the trunk/line port and a 1310-nm or 850-nm laser (depending on the SFP) for the client port. The card contains eight 12.5 degree downward tilt SFP modules for the client interfaces. For optical termination, each SFP uses two LC connectors, which are labeled TX and RX on the faceplate. There are two trunk port connectors (one for working and one for protect). Each is a dual-LC connector with a 45-degree downward angle.

10.9.6 Faceplates

Figure 10-23 shows the MXP_MR_2.5G and MXPP_MR_2.5G faceplates.

Figure 10-23 MXP_MR_2.5G and MXPP_MR_2.5G Faceplates

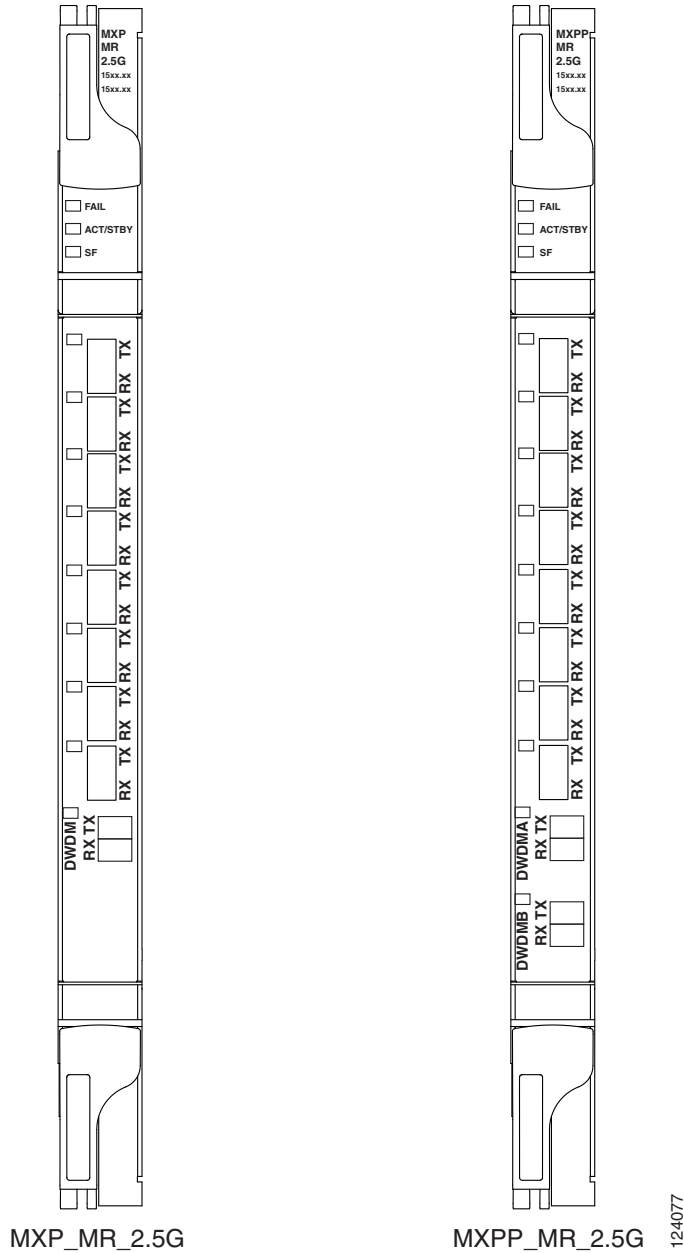

For information on safety labels for the cards, see the “10.2.2 Class 1M Laser Product Cards” section on page 10-11.

10.9.7 Block Diagram

Figure 10-24 shows a block diagram of the MXP_MR_2.5G card. The card has eight SFP client interfaces. Ports 1 and 2 can be used for GE, FC, FICON, or ESCON. Ports 3 through 8 are used for ESCON client interfaces. There are two SERDES blocks dedicated to the high-speed interfaces (GE, FC, FICON, and ESCON) and two SERDES blocks for the ESCON interfaces. A FPGA is provided to support different configurations for different modes of operation. This FPGA has a Universal Test and

Operations Physical Interface for ATM (UTOPIA) interface. A transceiver add/drop multiplexer (TADM) chip supports framing. Finally, the output signal is serialized and connected to the trunk front end with a direct modulation laser. The trunk receive signal is converted into an electrical signal with an avalanche photodiode (APD), is deserialized, and is then sent to the TADM framer and FPGA.

The MXPP_MR_2.5G is the same, except a 50/50 splitter divides the power at the trunk interface. In the receive direction, there are two APDs, two SERDES blocks, and two TADM framers. This is necessary to monitor both the working and protect paths. A switch selects one of the two paths to connect to the client interface.

Figure 10-24 MXP_MR_2.5G and MXPP_MR_2.5G Block Diagram

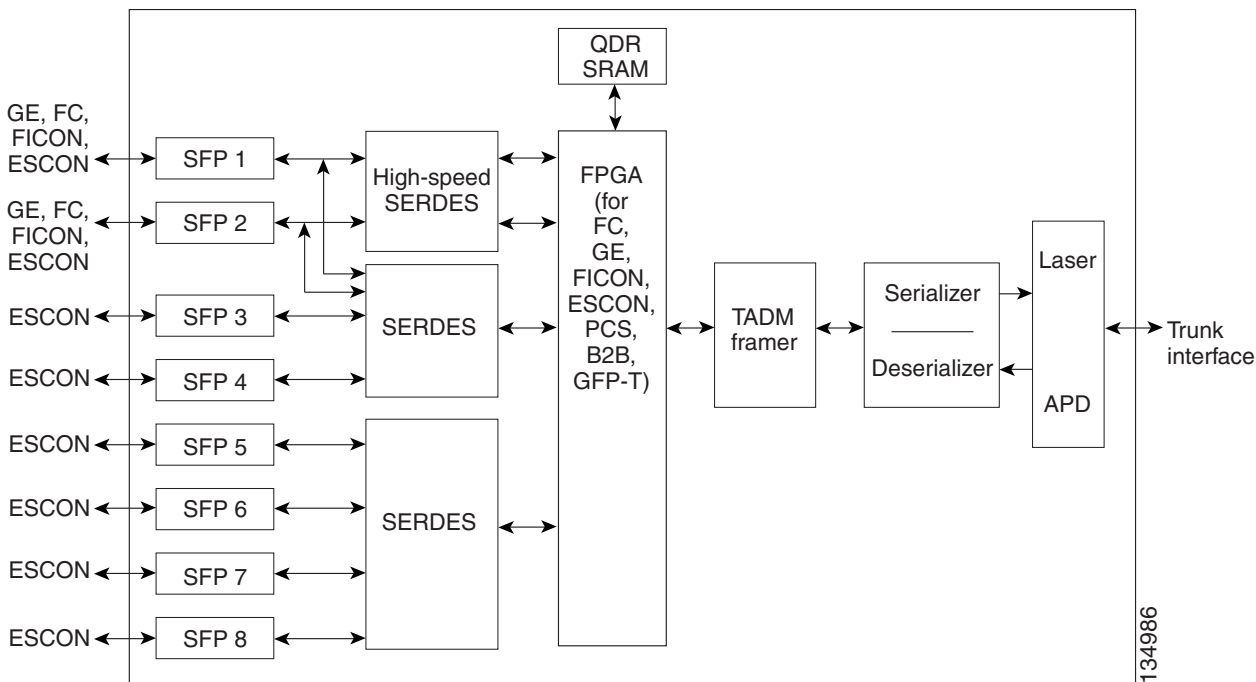

Caution

You must use a 20-dB fiber attenuator (15 to 25 dB) when working with the MXP_MR_2.5G and MXPP_MR_2.5G cards in a loopback configuration on the trunk port. Do not use direct fiber loopbacks with the MXP_MR_2.5G and MXPP_MR_2.5G cards. Using direct fiber loopbacks causes irreparable damage to the MXP_MR_2.5G and MXPP_MR_2.5G cards.

10.9.8 Automatic Laser Shutdown

The ALS procedure is supported on both client and trunk interfaces. On the client interface, ALS is compliant with ITU-T G.664 (6/99). On the data application and trunk interface, the switch on and off pulse duration is greater than 60 seconds. The on and off pulse duration is user-configurable. For details regarding ALS provisioning for the MXP_MR_2.5G and MXPP_MR_2.5G cards, refer to the *Cisco ONS 15454 DWDM Procedure Guide*.

10.9.9 MXP_MR_2.5G and MXPP_MR_2.5G Card-Level Indicators

Table 10-26 lists the card-level LEDs on the MXP_MR_2.5G and MXPP_MR_2.5G cards.

Table 10-26 MXP_MR_2.5G and MXPP_MR_2.5G Card-Level Indicators

Card-Level LED	Description
FAIL LED (Red)	Red indicates that the card's processor is not ready. This LED is on during reset. The FAIL LED flashes during the boot process. Replace the card if the red FAIL LED persists.
ACT/STBY LED Green (Active) Amber (Standby)	Green indicates that the card is operational (one or both ports active) and ready to carry traffic. Amber indicates that the card is operational and in standby (protect) mode.
SF LED (Amber)	Amber indicates a signal failure or condition such as LOS, LOF, or high BERs on one or more of the card's ports. The amber SF LED is also illuminated if the transmit and receive fibers are incorrectly connected. If the fibers are properly connected and the link is working, the LED turns off.

10.9.10 MXP_MR_2.5G and MXPP_MR_2.5G Port-Level Indicators

Table 10-27 lists the port-level LEDs on the MXP_MR_2.5G and MXPP_MR_2.5G cards.

Table 10-27 MXP_MR_2.5G and MXPP_MR_2.5G Port-Level Indicators

Port-Level LED	Description
Client LEDs (eight LEDs)	Green indicates that the port is carrying traffic (active) on the interface. Amber indicates that the port is carrying protect traffic (MXPP_MR_2.5G). Red indicates that the port has detected a loss of signal.
DWDM LED (MXP_MR_2.5G) Green (Active) Red (LOS)	Green indicates that the card is carrying traffic (active) on the interface. A red LED indicates that the interface has detected an LOS or LOC.
DWDMA and DWDMA LEDs (MXPP_MR_2.5G) Green (Active) Amber (Protect Traffic) Red (LOS)	Green indicates that the card is carrying traffic (active) on the interface. When the LED is amber, it indicates that the interface is carrying protect traffic in a splitter protection card (MXPP_MR_2.5G). A red LED indicates that the interface has detected an LOS or LOC.

10.10 MXP_MR_10DME_C and MXP_MR_10DME_L Cards

MXP_MR_10DME_L: (Cisco ONS 15454 only)

The MXP_MR_10DME_C and MXP_MR_10DME_L cards aggregate a mix of client SAN service client inputs (GE, FICON, and Fibre Channel) into one 10.0 Gbps STM-64/OC-192 DWDM signal on the trunk side. It provides one long-reach STM-64/OC-192 port per card and is compliant with Telcordia GR-253-CORE and ITU-T G.957.

The cards support aggregation of the following signal types:

- 1-Gigabit Fibre Channel
- 2-Gigabit Fibre Channel
- 4-Gigabit Fibre Channel
- 1-Gigabit Ethernet
- 1-Gigabit ISC-Compatible (ISC-1)
- 2-Gigabit ISC-Peer (ISC-3)

**Note**

On the card faceplates, the MXP_MR_10DME_C and MXP_MR_10DME_L cards are displayed as 10DME_C and 10DME_L, respectively.

**Caution**

The card can be damaged by dropping it. Handle it safely.

The MXP_MR_10DME_C and MXP_MR_10DME_L muxponders pass all SONET/SDH overhead bytes transparently.

The digital wrapper function (ITU-T G.709 compliant) formats the DWDM wavelength so that it can be used to set up GCCs for data communications, enable FEC, or facilitate PM. The MXP_MR_10DME_C and MXP_MR_10DME_L cards work with the OTN devices defined in ITU-T G.709. The cards support ODU1 to OTU2 multiplexing, an industry standard method for asynchronously mapping a SONET/SDH payload into a digitally wrapped envelope. See the [“10.7.7 Multiplexing Function”](#) section on page 10-36.

**Note**

Because the client payload cannot oversubscribe the trunk, a mix of client signals can be accepted, up to a maximum limit of 10 Gbps.

You can install MXP_MR_10DME_C and MXP_MR_10DME_L cards in Slots 1 to 6 and 12 to 17.

**Note**

The MXP_MR_10DME_C and MXP_MR_10DME_L cards are not compatible with the MXP_2.5G_10G card, which does not support transparent termination mode.

The MXP_MR_10DME_C card features a tunable 1550-nm C-band laser on the trunk port. The laser is tunable across 82 wavelengths on the ITU grid with 50-GHz spacing between wavelengths. The MXP_MR_10DME_L features a tunable 1580-nm L-band laser on the trunk port. The laser is tunable across 80 wavelengths on the ITU grid, also with 50-GHz spacing. Each card features four 1310-nm lasers on the client ports and contains five transmit and receive connector pairs (labeled) on the card faceplate. The cards use dual LC connectors on the trunk side and use SFP modules on the client side for optical cable termination. The SFP pluggable modules are SR or IR and support an LC fiber connector.

Table 10-28 shows the input data rate for each client interface, and the encapsulation method. The current version of the GFP-T G.7041 supports transparent mapping of 8B/10B block-coded protocols, including Gigabit Ethernet, Fibre Channel, ISC, and FICON.

In addition to the GFP mapping, 1-Gbps traffic on Port 1 or 2 of the high-speed SERDES is mapped to an STS-24c channel. If two 1-Gbps client signals are present at Port 1 and Port 2 of the high-speed SERDES, the Port 1 signal is mapped into the first STS-24c channel and the Port 2 signal into the second STS-24c channel. The two channels are then mapped into an OC-48 trunk channel.

Table 10-28 MXP_MR_10DME_C and MXP_MR_10DME_L Client Interface Data Rates and Encapsulation

Client Interface	Input Data Rate	GFP-T G.7041 Encapsulation
2G FC	2.125 Gbps	Yes
1G FC	1.06 Gbps	Yes
2G FICON/2G ISC-Compatible (ISC-1)/ 2G ISC-Peer (ISC-3)	2.125 Gbps	Yes
1G FICON/1G ISC-Compatible (ISC-1)/ 1G ISC-Peer (ISC-3)	1.06 Gbps	Yes
Gigabit Ethernet	1.25 Gbps	Yes

There are two FPGAs on each MXP_MR_10DME_C and MXP_MR_10DME_L, and a group of four ports is mapped to each FPGA. Group 1 consists of Ports 1 through 4, and Group 2 consists of Ports 5 through 8. Table 10-29 shows some of the mix and match possibilities on the various client data rates for Ports 1 through 4, and Ports 5 through 8. An X indicates that the data rate is supported in that port.

Table 10-29 Supported Client Data Rates for Ports 1 through 4 and Ports 5 through 8

Port (Group 1)	Port (Group 2)	Gigabit Ethernet	1G FC	2G FC	4G FC
1	5	X	X	X	X
2	6	X	X	—	—
3	7	X	X	X	—
4	8	X	X	—	—

GFP-T PM is available through RMON and trunk PM is managed according to Telcordia GR-253-CORE and ITU G.783/826. Client PM is achieved through RMON for FC and GE.

A buffer-to-buffer credit management scheme provides FC flow control. With this feature enabled, a port indicates the number of frames that can be sent to it (its buffer credit), before the sender is required to stop transmitting and wait for the receipt of a “ready” indication. The MXP_MR_10DME_C and MXP_MR_10DME_L cards support FC credit-based flow control with a buffer-to-buffer credit extension of up to 1600 km (994.1 miles) for 1G FC, up to 800 km (497.1 miles) for 2G FC, or up to 400 km (248.5 miles) for 4G FC. The feature can be enabled or disabled.

The MXP_MR_10DME_C and MXP_MR_10DME_L cards feature a 1550-nm laser for the trunk/line port and a 1310-nm or 850-nm laser (depending on the SFP) for the client ports. The cards contains eight 12.5 degree downward tilt SFP modules for the client interfaces. For optical termination, each SFP uses two LC connectors, which are labeled TX and RX on the faceplate. The trunk port is a dual-LC connector with a 45 degree downward angle.

The throughput of the MXP_MR_10DME_C and MXP_MR_10DME_L cards is affected by the following parameters:

- Distance extension—If distance extension is enabled on the card, it provides more throughput but more latency. If distance extension is disabled on the card, the buffer to buffer credits on the storage switch affects the throughput; higher the buffer to buffer credits higher is the throughput.



Note For each link to operate at the maximum throughput, it requires a minimum number of buffer credits to be available on the devices which the link connects to. The number of buffer credits required is a function of the distance between the storage switch extension ports and the link bandwidth, that is, 1G, 2G, or 4G. These buffer credits are provided by either the storage switch (if distance extension is disabled) or by both the storage switch and the card (if distance extension is enabled).

- Forward Error Correction (FEC)—If Enhanced FEC (E-FEC) is enabled on the trunk port of the card, the throughput is significantly reduced in comparison to standard FEC being set on the trunk port.



Note If distance extension is enabled on the card, the FEC status does not usually affect the throughput of the card.

- Payload size—The throughput of the card decreases with decrease in payload size.

The resultant throughput of the card is usually the combined effect of the above parameters.

10.10.1 Key Features

The MXP_MR_10DME_C and MXP_MR_10DME_L cards have the following high-level features:

- Onboard E-FEC processor: The processor supports both standard RS (specified in ITU-T G.709) and E-FEC, which allows an improved gain on trunk interfaces with a resultant extension of the transmission range on these interfaces. The E-FEC functionality increases the correction capability of the transponder to improve performance, allowing operation at a lower OSNR compared to the standard RS (237,255) correction algorithm. A new BCH algorithm implemented in E-FEC allows recovery of an input BER up to 1E-3.
- Pluggable client interface optic modules: The MXP_MR_10DME_C and MXP_MR_10DME_L cards have modular interfaces. Two types of optics modules can be plugged into the card. These include an OC-48/STM 16 SR-1 interface with a 7-km (4.3-mile) nominal range (for short range and intra-office applications) and an IR-1 interface with a range up to 40 km (24.9 miles). SR-1 is defined in Telcordia GR-253-CORE and in I-16 (ITU-T G.957). IR-1 is defined in Telcordia GR-253-CORE and in S-16-1 (ITU-T G.957).
- Y-cable protection: Supports Y-cable protection between the same card type only, on ports with the same port number and signal rate. See the “[10.19.1 Y-Cable Protection](#)” section on page 10-140 for more detailed information.
- High level provisioning support: The cards are initially provisioned using Cisco TransportPlanner software. Subsequently, the card can be monitored and provisioned using CTC software.
- ALS: A safety mechanism used in the event of a fiber cut. For details regarding ALS provisioning for the MXP_MR_10DME_C and MXP_MR_10DME_L cards, refer to the *Cisco ONS 15454 DWDM Procedure Guide*.

- Link monitoring and management: The cards use standard OC-48 OH bytes to monitor and manage incoming interfaces. The cards pass the incoming SDH/SONET data stream and its OH bytes transparently.
- Control of layered SONET/SDH transport overhead: The cards are provisionable to terminate regenerator section overhead. This is used to eliminate forwarding of unneeded layer overhead. It can help reduce the number of alarms and help isolate faults in the network.
- Automatic timing source synchronization: The MXP_MR_10DME_C and MXP_MR_10DME_L cards normally synchronize from the TCC2/TCC2P/TCC3 card. If for some reason, such as maintenance or upgrade activity, the TCC2/TCC2P/TCC3 is not available, the cards automatically synchronize to one of the input client interface clocks.



Note MXP_MR_10DME_C and MXP_MR_10DME_L cards cannot be used for line timing.

- Configurable squelching policy: The cards can be configured to squelch the client interface output if there is LOS at the DWDM receiver or if there is a remote fault. In the event of a remote fault, the card manages MS-AIS insertion.
- The cards are tunable across the full C band (MXP_MR_10DME_C) or full L band (MXP_MR_10DME_L), thus eliminating the need to use different versions of each card to provide tunability across specific wavelengths in a band.
- You can provision a string (port name) for each fiber channel/FICON interface on the MXP_MR_10DME_C and MXP_MR_10DME_L cards, which allows the MDS Fabric Manager to create a link association between that SAN port and a SAN port on a Cisco MDS 9000 switch.
- From Software Release 9.0, the fast switch feature of MXP_MR_10DME_C and MXP_MR_10DME_L cards along with the buffer-to-buffer credit recovery feature of MDS switches, prevents reinitialization of ISL links during Y-cable switchovers.

10.10.2 Faceplate

Figure 10-25 shows the MXP_MR_10DME_C and MXP_MR_10DME_L faceplates and block diagram.

Figure 10-25 MXP_MR_10DME_C and MXP_MR_10DME_L Faceplates and Block Diagram

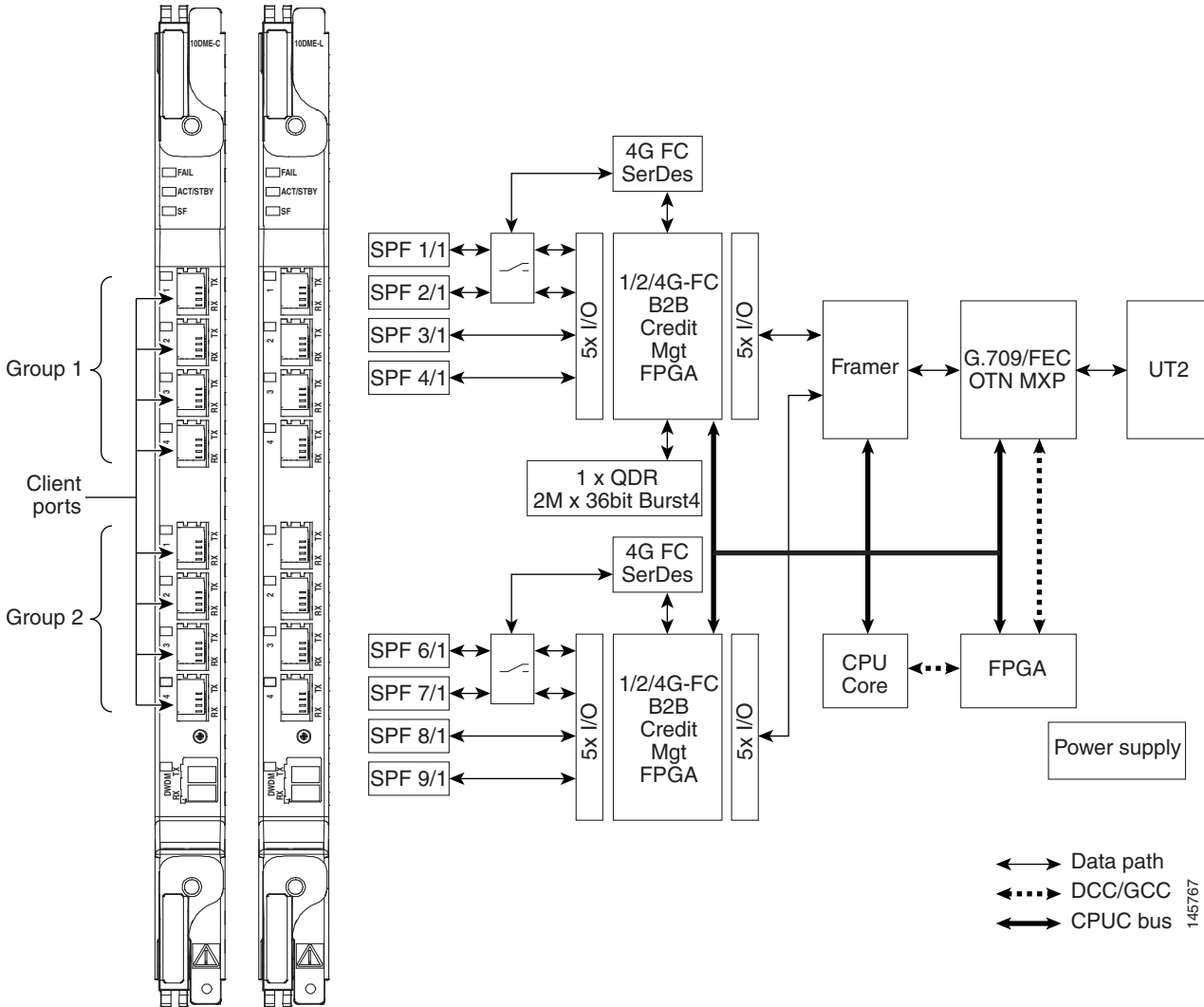

For information on safety labels for the cards, see the “10.2.2 Class 1M Laser Product Cards” section on page 10-11.



Caution

You must use a 20-dB fiber attenuator (15 to 25 dB) when working with the cards in a loopback on the trunk port. Do not use direct fiber loopbacks with the cards. Using direct fiber loopbacks causes irreparable damage to the MXP_MR_10DME_C and MXP_MR_10DME_L cards.

10.10.3 Wavelength Identification

The card uses trunk lasers that are wavelocked, which allows the trunk transmitter to operate on the ITU grid effectively. Both the MXP_MR_10DME_C and MXP_MR_10DME_L cards implement the UT2 module. The MXP_MR_10DME_C card uses a C-band version of the UT2 and the MXP_MR_10DME_L card uses an L-band version.

Table 10-30 describes the required trunk transmit laser wavelengths for the MXP_MR_10DME_C card. The laser is tunable over 82 wavelengths in the C band at 50-GHz spacing on the ITU grid.

Table 10-30 MXP_MR_10DME_C Trunk Wavelengths

Channel Number	Frequency (THz)	Wavelength (nm)	Channel Number	Frequency (THz)	Wavelength (nm)
1	196.00	1529.55	42	193.95	1545.72
2	195.95	1529.94	43	193.90	1546.119
3	195.90	1530.334	44	193.85	1546.518
4	195.85	1530.725	45	193.80	1546.917
5	195.80	1531.116	46	193.75	1547.316
6	195.75	1531.507	47	193.70	1547.715
7	195.70	1531.898	48	193.65	1548.115
8	195.65	1532.290	49	193.60	1548.515
9	195.60	1532.681	50	193.55	1548.915
10	195.55	1533.073	51	193.50	1549.32
11	195.50	1533.47	52	193.45	1549.71
12	195.45	1533.86	53	193.40	1550.116
13	195.40	1534.250	54	193.35	1550.517
14	195.35	1534.643	55	193.30	1550.918
15	195.30	1535.036	56	193.25	1551.319
16	195.25	1535.429	57	193.20	1551.721
17	195.20	1535.822	58	193.15	1552.122
18	195.15	1536.216	59	193.10	1552.524
19	195.10	1536.609	60	193.05	1552.926
20	195.05	1537.003	61	193.00	1553.33
21	195.00	1537.40	62	192.95	1553.73
22	194.95	1537.79	63	192.90	1554.134
23	194.90	1538.186	64	192.85	1554.537
24	194.85	1538.581	65	192.80	1554.940
25	194.80	1538.976	66	192.75	1555.343
26	194.75	1539.371	67	192.70	1555.747
27	194.70	1539.766	68	192.65	1556.151
28	194.65	1540.162	69	192.60	1556.555
29	194.60	1540.557	70	192.55	1556.959
30	194.55	1540.953	71	192.50	1557.36
31	194.50	1541.35	72	192.45	1557.77
32	194.45	1541.75	73	192.40	1558.173
33	194.40	1542.142	74	192.35	1558.578

Table 10-30 MXP_MR_10DME_C Trunk Wavelengths (continued)

Channel Number	Frequency (THz)	Wavelength (nm)	Channel Number	Frequency (THz)	Wavelength (nm)
34	194.35	1542.539	75	192.30	1558.983
35	194.30	1542.936	76	192.25	1559.389
36	194.25	1543.333	77	192.20	1559.794
37	194.20	1543.730	78	192.15	1560.200
38	194.15	1544.128	79	192.10	1560.606
39	194.10	1544.526	80	192.05	1561.013
40	194.05	1544.924	81	192.00	1561.42
41	194.00	1545.32	82	191.95	1561.83

Table 10-31 describes the required trunk transmit laser wavelengths for the MXP_MR_10DME_L card. The laser is fully tunable over 80 wavelengths in the L band at 50-GHz spacing on the ITU grid.

Table 10-31 MXP_MR_10DME_L Trunk Wavelengths

Channel Number	Frequency (THz)	Wavelength (nm)	Channel Number	Frequency (THz)	Wavelength (nm)
1	190.85	1570.83	41	188.85	1587.46
2	190.8	1571.24	42	188.8	1587.88
3	190.75	1571.65	43	188.75	1588.30
4	190.7	1572.06	44	188.7	1588.73
5	190.65	1572.48	45	188.65	1589.15
6	190.6	1572.89	46	188.6	1589.57
7	190.55	1573.30	47	188.55	1589.99
8	190.5	1573.71	48	188.5	1590.41
9	190.45	1574.13	49	188.45	1590.83
10	190.4	1574.54	50	188.4	1591.26
11	190.35	1574.95	51	188.35	1591.68
12	190.3	1575.37	52	188.3	1592.10
13	190.25	1575.78	53	188.25	1592.52
14	190.2	1576.20	54	188.2	1592.95
15	190.15	1576.61	55	188.15	1593.37
16	190.1	1577.03	56	188.1	1593.79
17	190.05	1577.44	57	188.05	1594.22
18	190	1577.86	58	188	1594.64
19	189.95	1578.27	59	187.95	1595.06
20	189.9	1578.69	60	187.9	1595.49
21	189.85	1579.10	61	187.85	1595.91

Table 10-31 MXP_MR_10DME_L Trunk Wavelengths (continued)

Channel Number	Frequency (THz)	Wavelength (nm)	Channel Number	Frequency (THz)	Wavelength (nm)
22	189.8	1579.52	62	187.8	1596.34
23	189.75	1579.93	63	187.75	1596.76
24	189.7	1580.35	64	187.7	1597.19
25	189.65	1580.77	65	187.65	1597.62
26	189.6	1581.18	66	187.6	1598.04
27	189.55	1581.60	67	187.55	1598.47
28	189.5	1582.02	68	187.5	1598.89
29	189.45	1582.44	69	187.45	1599.32
30	189.4	1582.85	70	187.4	1599.75
31	189.35	1583.27	71	187.35	1600.17
32	189.3	1583.69	72	187.3	1600.60
33	189.25	1584.11	73	187.25	1601.03
34	189.2	1584.53	74	187.2	1601.46
35	189.15	1584.95	75	187.15	1601.88
36	189.1	1585.36	76	187.1	1602.31
37	189.05	1585.78	77	187.05	1602.74
38	189	1586.20	78	187	1603.17
39	188.95	1586.62	79	186.95	1603.60
40	188.9	1587.04	80	186.9	1604.03

10.10.4 MXP_MR_10DME_C and MXP_MR_10DME_L Card-Level Indicators

Table 10-32 describes the three card-level LEDs on the MXP_MR_10DME_C and MXP_MR_10DME_L cards.

Table 10-32 MXP_MR_10DME_C and MXP_MR_10DME_L Card-Level Indicators

Card-Level LED	Description
Red FAIL LED	The red FAIL LED indicates that the card's processor is not ready. This LED is on during reset. The FAIL LED flashes during the boot process. Replace the card if the red FAIL LED persists.
ACT/STBY LED Green (Active) Amber (Standby)	If the ACT/STBY LED is green, the card is operational (one or more ports active) and ready to carry traffic. If the ACT/STBY LED is amber, the card is operational and in standby (protect) mode.
Amber SF LED	The amber SF LED indicates a signal failure or condition such as LOS, LOF, or high BERs on one or more of the card's ports. The amber SF LED is also on if the transmit and receive fibers are incorrectly connected. If the fibers are properly connected and the link is working, the light turns off.

10.10.5 MXP_MR_10DME_C and MXP_MR_10DME_L Port-Level Indicators

Table 10-33 describes the port-level LEDs on the MXP_MR_10DME_C and MXP_MR_10DME_L cards.

Table 10-33 MXP_MR_10DME_C and MXP_MR_10DME_L Port-Level Indicators

Port-Level LED	Description
Port LED (eight LEDs, four for each group, one for each SFP)	When green, the port LED indicates that the client port is either in service and receiving a recognized signal (that is, no signal fail), or Out of Service and Maintenance (OOS,MT or locked, maintenance) and the signal fail and alarms are being ignored.
Green/Red/Amber/Off	When red, the port LED indicates that the client port is in service but is receiving a signal fail (LOS). When amber, the port LED indicates that the port is provisioned and in a standby state. When off, the port LED indicates that the SFP is either not provisioned, out of service, not properly inserted, or the SFP hardware has failed.
Green DWDM LED	The green DWDM LED indicates that the DWDM port is in service and that it is receiving a recognized signal.

10.11 40G-MXP-C Card

The 40G-MXP-C card aggregates a variety of client service inputs (GigabitEthernet, Fibre Channel, OTU2, OTU2e, and OC192) into one 40.0 Gbps OTU3/OTU3e signal on the trunk side. The 40G-MXP-C card supports aggregation of the following signals:

- With overclock enabled on the trunk port:
 - 10-Gigabit Fibre Channel
 - OTU2e
- With overclock disabled on the trunk port:
 - 8-Gigabit Fibre Channel
 - 10-GigabitEthernet LAN-Phy (GFP framing)
 - 10-GigabitEthernet LAN-Phy (WIS framing)
 - OC-192/STM-64
 - OTU2



Caution

Handle the card with care. Dropping or misuse of the card could result in permanent damage.

The 40G-MXP-C muxponder passes all SONET/SDH overhead bytes transparently, section, or line termination.

The digital wrapper function (ITU-T G.709 compliant) formats the DWDM wavelength so that it can be used to set up GCCs for data communications, enable FEC, or facilitate performance monitoring. The 40G-MXP-C card work with the OTN devices defined in ITU-T G.709. The card supports ODTU23 multiplexing, an industry standard method for asynchronously mapping client payloads into a digitally

wrapped envelope. See the “10.7.7 Multiplexing Function” section on page 10-36.

You can install and provision the 40G-MXP-C card in a linear configuration in:

- Slots 1 to 5 and 12 to 16 in ONS 15454 DWDM chassis
- Slot 2 in ONS 15454 M2 chassis
- Slots 2 to 6 in ONS 15454 M6 chassis

The 40G-MXP-C card client port interoperates with all the existing TXP/MXP (OTU2 trunk) cards.

The auto negotiation is not supported on 40G-MXP-C card in 8G FC client mode. Hence, during interoperation, the auto negotiation of the 8G-FC client port of the other device connected to 8G-FC client port on 40G-MXP-C card must be set to Fixed/Disabled.

The 40G-MXP-C card client port does not interoperate with OTU2_XP card when the signal rate is OTU1e (11.049 Gbps) and the “No Fixed Stuff” option is enabled on the trunk port of OTU2_XP card.

For OTU2 and OTU2e client protocols, Enhanced FEC (EFEC) is not supported in Port 1 of the 40G-MXP-C card. Table 10-34 lists the FEC configuration supported on OTU2/OTU2e protocol for 40G-MXP-C card.

Table 10-34 40G-MXP-C Client Interface Data Rates

40G-MXP-C Client Port	FEC Configuration Supported on OTU2/OTU2e Client Protocol
Port 1	Only Standard FEC
Port 2	Standard and Enhanced FEC
Port 3	Standard and Enhanced FEC
Port 4	Standard and Enhanced FEC

When setting up the card for the first time, or when the card comes up after clearing the LOS-P condition due to fiber cut, the trunk port of the 40G-MXP-C card takes about six minutes to lock a signal. The trunk port of the 40G-MXP-C card raises an OTUK-LOF alarm when the card comes up. The alarm clears when the trunk port locks the signal.

When protection switch occurs on the 40G-MXP-C card, the recovery from PSM protection switch takes about 3 to 4 minutes.

The 40G-MXP-C card is tunable over C-band on the trunk port. The 40G-MXP-C card supports pluggable XFPs on the client ports on the card faceplate. The card uses dual LC connectors on the trunk side, and XFP modules on the client side for optical cable termination. The XFP pluggable modules are SR, LR, MM, DWDM, or CWDM and support an LC fiber connector. The 40G-MXP-C card contains four XFP modules for the client interfaces. For optical termination, each XFP uses two LC connectors, which are labeled TX and RX on the faceplate. The trunk port is a dual-LC connector facing downward at 45 degrees.

Table 10-35 shows the input data rate for each client interface.

Table 10-35 40G-MXP-C Client Interface Input Data Rates

Client Interface	Input Data Rate
8-Gigabit Fibre Channel	8.48 Gbps
10-Gigabit Fibre Channel	10.519 Gbps
10-GigabitEthernet LAN-Phy	10.312 Gbps

Table 10-35 40G-MXP-C Client Interface Input Data Rates (continued)

Client Interface	Input Data Rate
10-GigabitEthernet WAN-Phy	9.953 Gbps
OC-192/STM-64	9.953 Gbps
OTU2	10.709 Gbps
OTU2e	11.096 Gbps

10.11.1 Key Features

The 40G-MXP-C card comprises of the following key features:

- The 40G-MXP-C card uses the RZ-DQPSK 40G modulation format.
- Onboard E-FEC processor: The E-FEC functionality improves the correction capability of the transponder to improve performance, allowing operation at a lower OSNR compared to the standard RS (239,255) correction algorithm. A new BCH algorithm implemented (according to G.975.1 I.7) in E-FEC allows recovery of an input BER up to 1E-3. The 40G-MXP-C card supports both standard RS (specified in ITU-T G.709) and E-FEC standard, which allows an improved gain on trunk interfaces with a resultant extension of the transmission range on these interfaces.
- Y-cable protection: Supports Y-cable protection between the same card type only, on ports with the same port number and signal rate. For more information on Y-cable protection, see “[10.19 Y-Cable and Splitter Protection](#)” section on page 10-140.



Note Y-cable cannot be created on 10 GE port when WIS framing is enabled on the 40G-MXP-C card.

- Unidirectional regeneration: The 40G-MXP-C card supports unidirectional regeneration configuration. Each 40G-MXP-C card in the configuration regenerates the signal received from another 40G-MXP-C card in one direction.



Note When you configure the 40G-MXP-C card in Unidirectional Regen mode, ensure that the payload is not configured on pluggable port modules of the 40G-MXP-C card.

Figure 10-26 shows a typical unidirectional regeneration configuration.

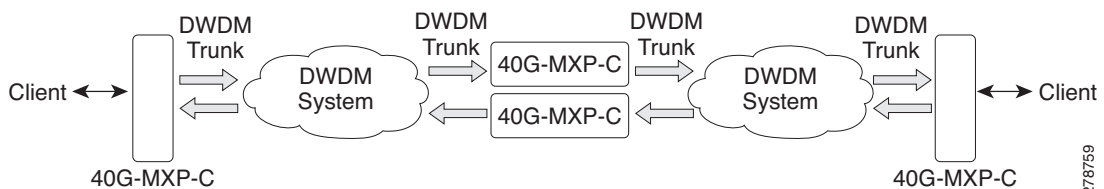
Figure 10-26 40G-MXP-C Cards in Unidirectional Regeneration Configuration

- High level provisioning support: The cards are initially provisioned using Cisco Transport Planner software. Subsequently, the card can be monitored and provisioned using CTC software.

- Automatic Laser Shutdown (ALS): A safety mechanism used in the event of a fiber cut. The Auto Restart ALS option is supported only for OC192/STM64 and OTU2 payloads. The Manual Restart ALS option is supported for all payloads. For more information on ALS provisioning for the 40G-MXP-C card, see the *Cisco ONS 15454 DWDM Procedure Guide*.
- Control of layered SONET/SDH transport overhead: The cards are provisionable to terminate regenerator section overhead. This is used to eliminate forwarding of unneeded layer overhead. It can help reduce the number of alarms and help isolate faults in the network.
- Automatic timing source synchronization: The 40G-MXP-C card synchronizes to the TCC2/TCC2P/TCC3/TNC/TSC card. If for some reason, such as maintenance or upgrade activity, the TCC2/TCC2P/TCC3/TNC/TSC card is not available, the cards automatically synchronize to one of the input client interface clocks.
- Squelching policy: The cards are set to squelch the client interface output if there is LOS at the DWDM receiver, or if there is a remote fault. In the event of a remote fault, the card manages MS-AIS insertion.
- The card is tunable across the full C band wavelength.

10.11.2 Faceplate and Block Diagram

Figure 10-27 shows the 40G-MXP-C card faceplate and block diagram.

Figure 10-27 40G-MXP-C Faceplate and Block Diagram

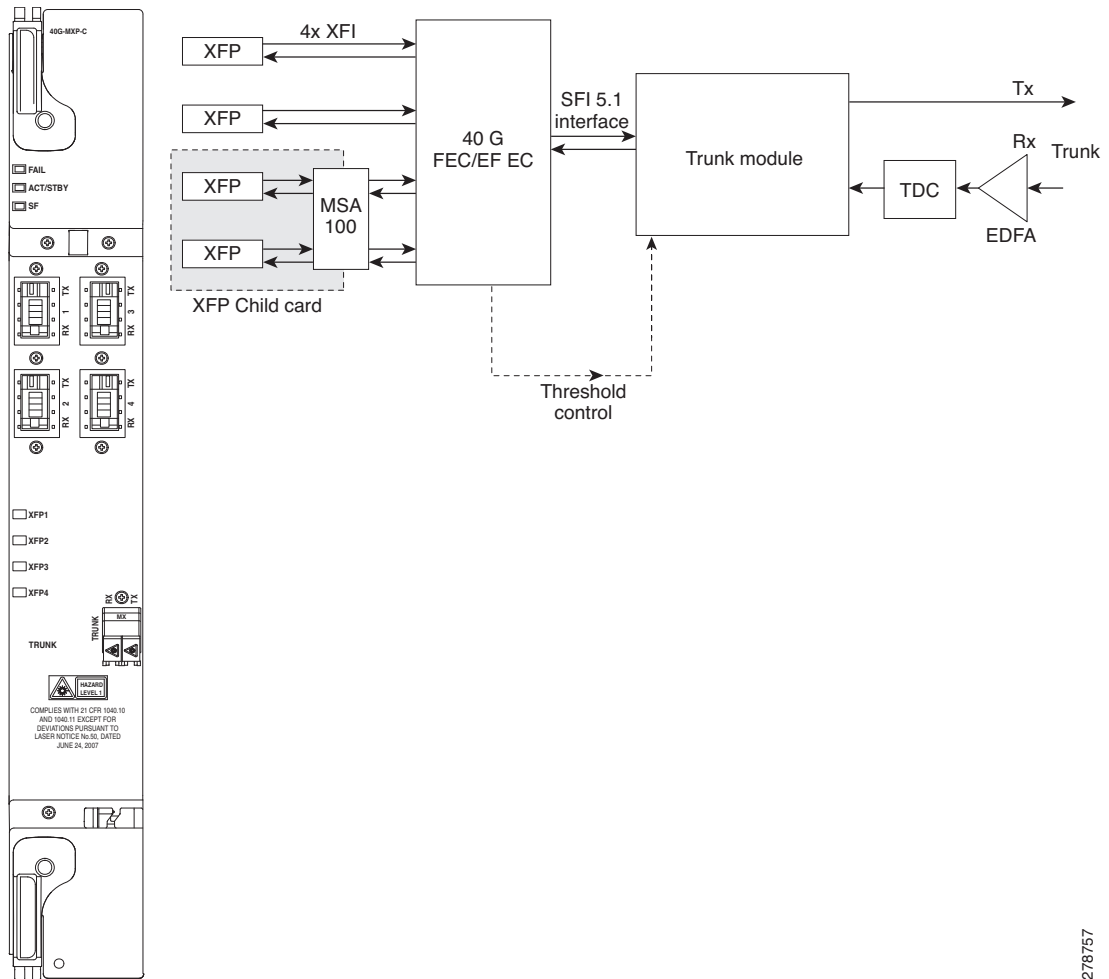

278757

For information on safety labels for the cards, see the “10.2.2 Class 1M Laser Product Cards” section on page 10-11.

**Caution**

You must use a 20-dB fiber attenuator (15 to 25 dB) when working with the cards in a loopback on the trunk port. Do not use direct fiber loopbacks with the cards. Using direct fiber loopbacks causes irreparable damage to the 40G-MXP-C card.

10.11.3 Wavelength Identification

The card uses trunk lasers that are wavelocked, which allows the trunk transmitter to operate on the ITU grid effectively. The 40G-MXP-C card implements the UT2 module. The 40G-MXP-C card uses a C-band version of the UT2.

[Table 10-36](#) lists the required trunk transmit laser wavelengths for the 40G-MXP-C card. The laser is tunable over 82 wavelengths in the C band at 50-GHz spacing on the ITU grid.

Table 10-36 40G-MXP-C Trunk Wavelengths

Channel Number	Frequency (THz)	Wavelength (nm)	Channel Number	Frequency (THz)	Wavelength (nm)
1	196.00	1529.55	42	193.95	1545.72
2	195.95	1529.94	43	193.90	1546.119
3	195.90	1530.334	44	193.85	1546.518
4	195.85	1530.725	45	193.80	1546.917
5	195.80	1531.116	46	193.75	1547.316
6	195.75	1531.507	47	193.70	1547.715
7	195.70	1531.898	48	193.65	1548.115
8	195.65	1532.290	49	193.60	1548.515
9	195.60	1532.681	50	193.55	1548.915
10	195.55	1533.073	51	193.50	1549.32
11	195.50	1533.47	52	193.45	1549.71
12	195.45	1533.86	53	193.40	1550.116
13	195.40	1534.250	54	193.35	1550.517
14	195.35	1534.643	55	193.30	1550.918
15	195.30	1535.036	56	193.25	1551.319
16	195.25	1535.429	57	193.20	1551.721
17	195.20	1535.822	58	193.15	1552.122
18	195.15	1536.216	59	193.10	1552.524
19	195.10	1536.609	60	193.05	1552.926
20	195.05	1537.003	61	193.00	1553.33
21	195.00	1537.40	62	192.95	1553.73
22	194.95	1537.79	63	192.90	1554.134
23	194.90	1538.186	64	192.85	1554.537
24	194.85	1538.581	65	192.80	1554.940
25	194.80	1538.976	66	192.75	1555.343
26	194.75	1539.371	67	192.70	1555.747
27	194.70	1539.766	68	192.65	1556.151
28	194.65	1540.162	69	192.60	1556.555
29	194.60	1540.557	70	192.55	1556.959
30	194.55	1540.953	71	192.50	1557.36
31	194.50	1541.35	72	192.45	1557.77
32	194.45	1541.75	73	192.40	1558.173
33	194.40	1542.142	74	192.35	1558.578
34	194.35	1542.539	75	192.30	1558.983
35	194.30	1542.936	76	192.25	1559.389

Table 10-36 40G-MXP-C Trunk Wavelengths (continued)

Channel Number	Frequency (THz)	Wavelength (nm)	Channel Number	Frequency (THz)	Wavelength (nm)
36	194.25	1543.333	77	192.20	1559.794
37	194.20	1543.730	78	192.15	1560.200
38	194.15	1544.128	79	192.10	1560.606
39	194.10	1544.526	80	192.05	1561.013
40	194.05	1544.924	81	192.00	1561.42
41	194.00	1545.32	82	191.95	1561.83

10.11.4 40G-MXP-C Card-Level Indicators

Table 10-37 describes the three card-level indicators on the 40G-MXP-C card.

Table 10-37 40G-MXP-C Card-Level Indicators

Card-Level Indicator	Description
Red FAIL LED	The red FAIL LED indicates that the card's processor is not ready. This LED is on during reset. The FAIL LED flashes during the boot process. Replace the card if the red FAIL LED persists.
ACT/STBY LED Green (Active) Amber (Standby)	If the ACT/STBY LED is green, the card is operational (one or more ports active) and ready to carry traffic. If the ACT/STBY LED is amber, the card is operational and in standby (protect) mode.
Amber SF LED	The amber SF LED indicates a signal failure or condition such as LOS, LOF, or high BERs on one or more of the card's ports. The amber SF LED is also on if the transmit and receive fibers are incorrectly connected. If the fibers are properly connected and the link is working, the light turns off.

10.11.5 40G-MXP-C Card Port-Level Indicators

Table 10-38 describes the port-level indicators on the 40G-MXP-C card.

Table 10-38 40G-MXP-C Card Port-Level Indicators

Port-Level Indicator	Description
Port LED (eight LEDs, four for each group, one for each XFP)	The green port LED indicates that the client port is either in service and receiving a recognized signal (that is, no signal fail), or Out of Service and Maintenance (OOS,MT or locked, maintenance) and the signal fail and alarms are being ignored.
Green/Red/Amber/Off	The red port LED indicates that the client port is in service but is receiving a signal fail (LOS). The amber port LED indicates that the port is provisioned and in a standby state. The port LED, when switched off, indicates that the SFP is either not provisioned, out of service, not properly inserted, or the SFP hardware failed.
Green DWDM LED	The green DWDM LED indicates that the DWDM port is in service and that it is receiving a recognized signal.

10.12 GE_XP, 10GE_XP, GE_XPE, and 10GE_XPE Cards

GE_XP, 10GE_XP, GE_XPE, and 10GE_XPE cards are Gigabit Ethernet Xponders for the ONS 15454 ANSI and ETSI platforms.



Note

GE_XPE card is the enhanced version of the GE_XP card and 10GE_XPE card is the enhanced version of the 10GE_XP card.

The cards aggregate Ethernet packets received on the client ports for transport on C-band trunk ports that operate on a 100-GHz grid. The trunk ports operate with ITU-T G.709 framing and either FEC or E-FEC. The GE_XP and 10GE_XP cards are designed for bulk point-to-point transport over 10GE LAN PHY wavelengths for Video-on-Demand (VOD), or broadcast video across protected 10GE LAN PHY wavelengths. The GE_XPE and 10GE_XPE cards are designed for bulk GE_XPE or 10GE_XPE point-to-point, point-to-multipoint, multipoint-to-multipoint transport over 10GE LAN PHY wavelengths for Video-on-Demand (VOD), or broadcast video across protected 10GE LAN PHY wavelengths.

You can install and provision the GE_XP, and GE_XPE cards in a linear configuration in:

- Slots 1 to 5 and 12 to 16 in ONS 15454 DWDM chassis
- Slot 2 in ONS 15454 M2 chassis
- Slots 2 to 6 in ONS 15454 M6 chassis

The 10GE_XP and 10GE_XPE cards can be installed in Slots 1 through 6 or 12 through 17. The GE_XP and GE_XPE are double-slot cards with twenty Gigabit Ethernet client ports and two 10 Gigabit Ethernet trunk ports. The 10GE_XP and 10GE_XPE are single-slot cards with two 10 Gigabit Ethernet client ports and two 10 Gigabit Ethernet trunk ports. The client ports support SX, LX, and ZX SFPs and SR and 10GBASE-LR XFPs. (LR2 XFPs are not supported.) The trunk ports support a DWDM XFP.

The RAD pluggables (ONS-SC-E3-T3-PW= and ONS-SC-E1-T1-PW=) do not support:

- No loopbacks (Terminal or Facility)
- RAI (Remote Alarm Indication) alarm
- AIS and LOS alarm

Caution

A fan-tray assembly (15454E-CC-FTA for the ETSI shelf, or 15454-CC-FTA for the ANSI shelf) must be installed in a shelf where a GE_XP, 10GE_XP, GE_XPE, or 10GE_XPE card is installed.

GE_XP, 10GE_XP, GE_XPE, and 10GE_XPE cards can be provisioned to perform different Gigabit Ethernet transport roles. All the cards can work as Layer 2 switches. However, the 10GE_XP and 10GE_XPE cards can also perform as a 10 Gigabit Ethernet transponders (10GE TXP mode), and the GE_XP and GE_XPE can perform as a 10 Gigabit Ethernet or 20 Gigabit Ethernet muxponders (10GE MXP or 20GE MXP mode). [Table 10-39](#) shows the card modes supported by each card.

Note

Changing the GE_XP, 10GE_XP, GE_XPE, or 10GE_XPE card mode requires the ports to be in a OOS-DSBL (ANSI) or Locked, disabled (ETSI) service state. In addition, no circuits can be provisioned on the cards when the mode is being changed.

Table 10-39 GE_XP, 10GE_XP, GE_XPE, and 10GE_XPE Card Modes

Card Mode	Cards	Description
Layer 2 Ethernet switch	GE_XP 10GE_XP GE_XPE 10GE_XPE	Provides capability to switch between any two ports irrespective of client or trunk port. Supported Ethernet protocols and services include 1+1 protection, QoS (Quality of Service), CoS (Class of Service), QinQ, MAC learning, MAC address retrieval, service provider VLANs (SVLANs), IGMP snooping and Multicast VLAN Registration (MVR), link integrity, and other Ethernet switch services.
10GE TXP	10GE_XP 10GE_XPE	Provides a point-to-point application in which each 10 Gigabit Ethernet client port is mapped to a 10 Gigabit Ethernet trunk port.
10GE MXP 20GE MXP	GE_XP GE_XPE	Provides the ability to multiplex the twenty Gigabit Ethernet client ports on the card to one or both of its 10 Gigabit Ethernet trunk ports. The card can be provisioned as a single MXP with twenty Gigabit Ethernet client ports mapped to one trunk port (Port 21) or as two MXPs with ten Gigabit Ethernet client ports mapped to a trunk port (Ports 1 to 10 mapped to Port 21, and Ports 11-20 mapped to Port 22).

10.12.1 Key Features

The GE_XP, 10GE_XP, GE_XPE, and 10GE_XPE cards have the following high-level features:

- Link Aggregation Control Protocol (LACP) that allows you to bundle several physical ports together to form a single logical channel.
- Ethernet Connectivity Fault Management (CFM) protocol that facilitates proactive connectivity monitoring, fault verification, and fault isolation.

- Ethernet Operations, Administration, and Maintenance (OAM) protocol that facilitates link monitoring, remote failure indication, and remote loopback.
- Resilient Ethernet Protocol (REP) that controls network loops, handles link failures, and improves convergence time.
- Configurable service VLANs (SVLANs) and customer VLANs (CVLANs).
- Ingress rate limiting that can be applied on both SVLANs and CVLANs. You can create SVLAN and CVLAN profiles and can associate a SVLAN profile to both UNI and NNI ports; however, you can associate a CVLAN profile only to UNI ports.
- CVLAN rate limiting that is supported for QinQ service in selective add mode.
- Differentiated Services Code Point (DSCP) to class of service (CoS) mapping that you can configure for each port. You can configure the CoS of the outer VLAN based on the incoming DSCP bits. This feature is supported only on GE_XPE and 10GE_XPE cards.
- Ports, in Layer 2 switch mode, can be provisioned as network-to-network interfaces (NNIs) or user-network interfaces (UNIs) to facilitate service provider to customer traffic management.
- Broadcast drop-and-continue capability for VOD and broadcast video applications.
- Gigabit Ethernet MXP, TXP, and Layer 2 switch capability over the ONS 15454 DWDM platform.
- Compatible with the ONS 15454 ANSI high-density shelf assembly, the ONS 15454 ETSI shelf assembly, ONS 15454 ETSI high-density shelf assembly, ONS 15454 M2, and the ONS 15454 M6 shelf assemblies. Compatible with TCC2, TCC2P, TCC3, TNC, and TSC cards.
- Far-End Laser Control (FELC) that is supported on copper SFPs from Release 8.52 and later releases. For more information on FELC, see the [“10.20 Far-End Laser Control” section on page 10-143](#).
- Layer 2 switch mode that provides VLAN translation, QinQ, ingress CoS, egress QoS, Fast Ethernet protection switching, and other Layer 2 Ethernet services.
- Interoperable with TXP_MR_10E and TXP_MR_10E_C cards. Also interoperable with Cisco Catalyst 6500 and Cisco 7600 series Gigabit Ethernet, 10 GE interfaces and CRS-1 10GE interfaces.
- The GE_XP and GE_XPE cards have twenty Gigabit Ethernet client ports and two 10 Gigabit Ethernet trunk ports. The 10GE_XP and 10GE_XPE cards have two 10 Gigabit Ethernet client ports and two 10 Gigabit Ethernet trunk ports. The client Gigabit Ethernet signals are mapped into an ITU-T G.709 OTU2 signal using standard ITU-T G.709 multiplexing when configured in one of the MXP modes (10GE MXP or 20GE MXP).
- ITU-T G.709 framing with standard Reed-Soloman (RS) (255,237) FEC. Performance monitoring and ITU-T G.709 Optical Data Unit (ODU) synchronous and asynchronous mapping. E-FEC with ITU-T G.709 ODU and 2.7 Gbps with greater than 8 dB coding gain.
- IEEE 802.3 frame format that is supported for 10 Gigabit Ethernet interfaces. The minimum frame size is 64 bytes. The maximum frame size is user-provisionable.
- MAC learning capability in Layer 2 switch mode.
- MAC address retrieval in cards provisioned in the L2-over-DWDM mode.
- When a port is in UNI mode, tagging can be configured as transparent or selective. In transparent mode, only SVLANs in the VLAN database of the node can be configured. In selective mode, a CVLAN- to-SVLAN relationship can be defined.
- Layer 2 VLAN port mapping that allows the cards to be configured as multiple Gigabit Ethernet TXPs and MXPs.
- Y-cable protection is configurable in TXP and MXP modes.

- Two protection schemes are available in Layer 2 mode. They are:
 - 1+1 protection—Protection scheme to address card, port, or shelf failures for client ports.
 - Fast Automatic Protection—Protection scheme to address card, port, or shelf failures for trunk ports.
- End-to-end Ethernet link integrity.
- Pluggable client interface optic modules (SFPs and XFPs)—Client ports support tri-rate SX, LX, and ZX SFPs, and 10-Gbps SR1 XFPs.
- Pluggable trunk interface optic modules; trunk ports support the DWDM XFP.
- Internet Group Management Protocol (IGMP) snooping that restricts the flooding of multicast traffic by forwarding multicast traffic to those interfaces where a multicast device is present.
- Multicast VLAN Registration (MVR) for applications using wide-scale deployment of multicast traffic across an Ethernet ring-based service provider network.
- Ingress CoS that assigns a CoS value to the port from 0 (highest) to 7 (lowest) and accepts CoS of incoming frames.
- Egress QoS that defines the QoS capabilities for the egress port.
- MAC address learning that facilitates switch processing.
- Storm Control that limits the number of packets passing through a port. You can define the maximum number of packets allowed per second for the following types of traffic: Broadcast, Multicast, and Unicast. The threshold for each type of traffic is independent and the maximum number of packets allowed per second for each type of traffic is 16777215.

10.12.2 Protocol Compatibility list

Table 10-40 lists the protocol compatibility for GE_XP, 10GE_XP, GE_XPE, and 10GE_XPE cards.

Table 10-40 Protocol Compatibility List for GE_XP, 10GE_XP, GE_XPE, and 10GE_XPE Cards

Protocol	L1	1+1	FAPS	IGMP	REP	LACP	CFM	EFM
L1		No	Yes	Yes	No	No	Yes	No
1+1	No		Yes	Yes	No	No	Yes	No
FAPS	Yes	Yes		Yes	No	No	Yes	No
IGMP	Yes	Yes	Yes		Yes	No	Yes	No
REP	No	No	No	Yes		No	Yes	No
LACP	No	No	No	No	No		No	No
CFM	Yes	Yes	Yes	Yes	Yes	No		No
EFM	No	No	No	No	No	No	No	

10.12.3 Faceplate and Block Diagram

Figure 10-28 shows the GE_XP faceplate and block diagram. The GE_XPE faceplate and block diagram looks the same.

Figure 10-28 GE_XP and GE_XPE Faceplates and Block Diagram

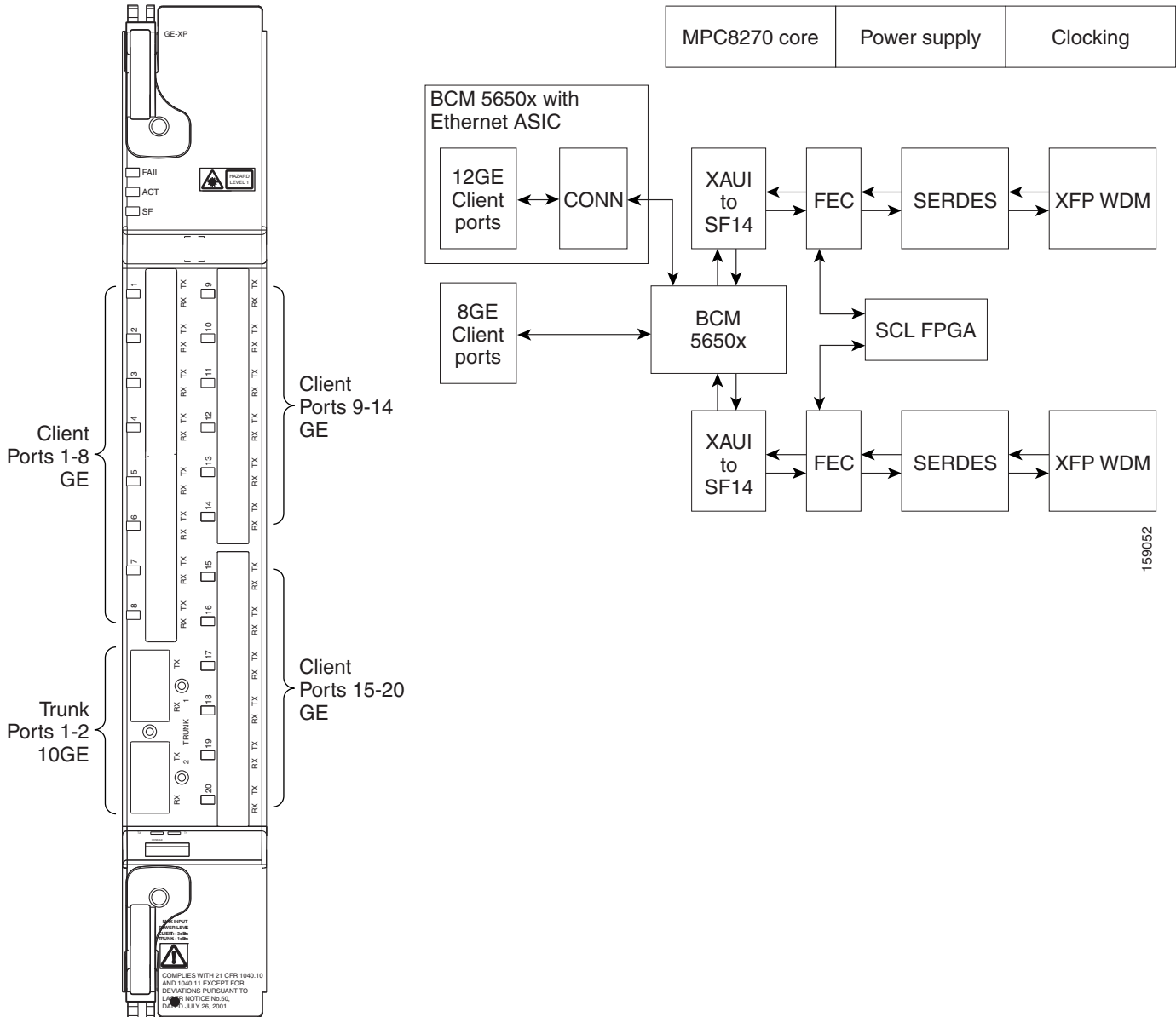

The GE_XP, 10GE_XP, GE_XPE, and 10GE_XPE cards have two trunk ports. The GE_XP and GE_XPE trunk ports are displayed as follows:

- Trunk 1 and Trunk 2 on the faceplate
- 21-1 and 22-1 on CTC
- 21 (Trunk) and 22 (Trunk) on the Optics Thresholds table

Figure 10-29 shows the 10GE_XP faceplate and block diagram. The 10 GE_XPE faceplate and block diagram looks the same.

Figure 10-29 10GE_XP and 10GE_XPE Faceplates and Block Diagram

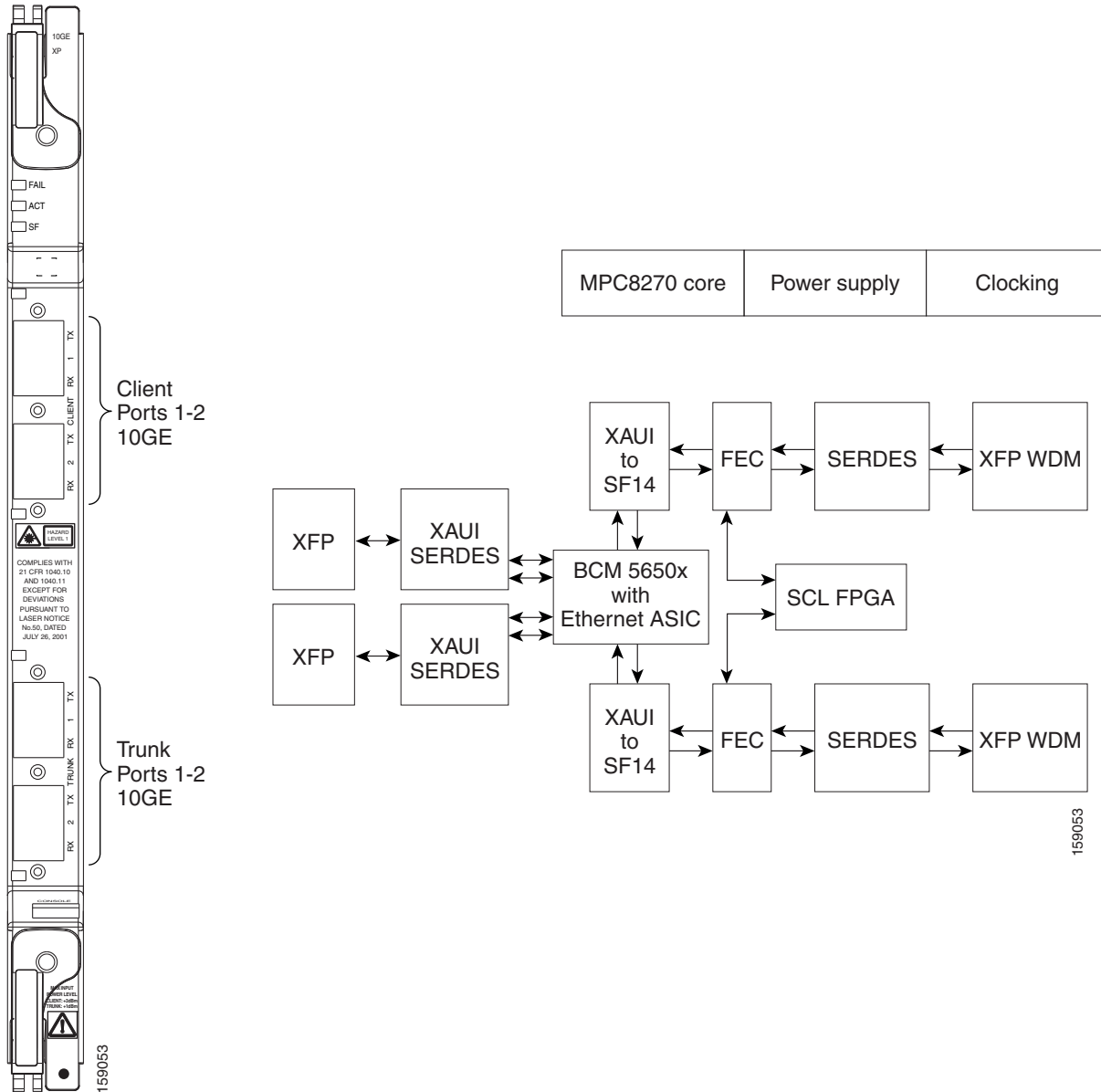

The 10GE_XP and 10GE_XPE card trunk ports are displayed as follows:

- Trunk 1 and Trunk 2 on the faceplate
- 3-1 and 4-1 on CTC
- 3 (Trunk) and 4 (Trunk) on the Optics Thresholds table

For information on safety labels for the cards, see the “10.2.2 Class 1M Laser Product Cards” section on page 10-11.



Caution

You must use a 20-dB fiber attenuator (15 to 25 dB) when working with the cards in a loopback on the trunk port. Do not use direct fiber loopbacks with the cards. Using direct fiber loopbacks causes irreparable damage to the GE_XP, 10GE_XP, GE_XPE, and 10GE_XPE cards.

10.12.4 Client Interface

The client interface is implemented with separately orderable SFP or XFP modules. The client interfaces support the following tri-rate SFPs and XFPs using dual LC connectors and multimode fiber:

- SFP - GE/1G-FC/2G-FC - 850 nm - MM - LC (PID ONS-SE-G2F-SX)
- SFP - GE/1G-FC/2G-FC 1300 nm - SM - LC (PID ONS-SE-G2F-LX)
- SFP - GE/1G-FC/2G-FC 1300 nm - SM - LC (PID ONS-SE-G2F-ZX)
- SFP - 10/100/1000Base-T - Copper (PID ONS-SE-ZE-EL) Intra office up to 100; Cable: RJ45 STP CAT5, CAT5E, and CAT6
- SFP - 1000Base BX D/Gigabit Ethernet 1550 nm - SM - LC (PID ONS-SE-GE-BXD)
- SFP - 1000Base BX U/Gigabit Ethernet 1550 nm - SM - LC (PID ONS-SE-GE-BXU)
- SFP - Fast Ethernet 1310 nm - SM - LC (PID ONS-SI-100-LX10)
- SFP - Fast Ethernet 1310 nm - MM - LC (PID ONS-SI-100-FX)
- SFP - Fast Ethernet over DS1/E1 - SM - LC (PID ONS-SC-EOP1) (GE_XPE only)
- SFP - Fast Ethernet over DS3/E3 - SM - LC (PID ONS-SC-EOP3) (GE_XPE only)
- SFP - E1/DS1 over Fast Ethernet - SM - LC (PID ONS-SC-E1-T1-PW) (GE_XPE only)
- SFP - E3/DS3 PDH over Fast Ethernet - SM - LC (PID ONS-SC-E3-T3-PW) (GE_XPE only)



Note

The recommended topology for using ONS-SC-E1-T1-PW and ONS-SC-E3-T3-PW SFPs is shown in Figure 10-30.

Figure 10-30 Recommended Topology for Using ONS-SC-E1-T1-PW and ONS-SC-E3-T3-PW SFPs

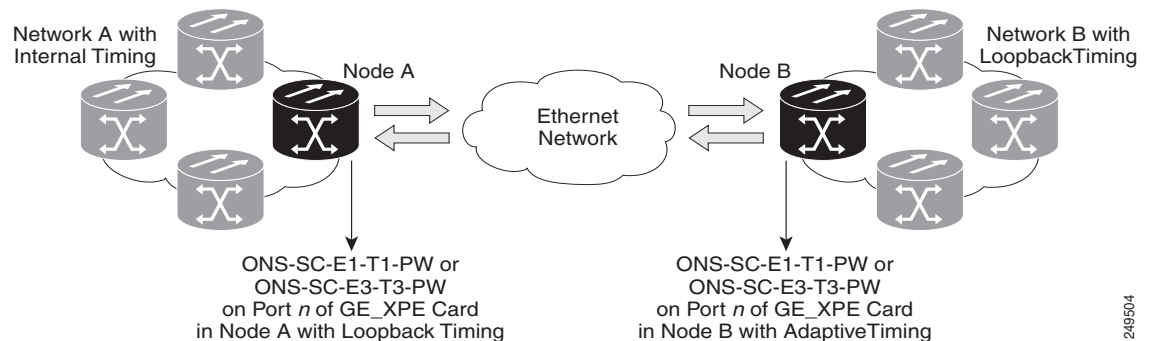

248504

The client interfaces support the following dual-rate XFP using dual LC connectors and single-mode fiber:

- XFP - OC-192/STM-64/10GE/10-FC/OTU2 - 1310 SR - SM LC (PID: ONS-XC-10G-S1)
- XFP - 10GE - 1550 nm - SM - LC (PID ONS-XC-10G-L2)
- XFP - 10GE - 1550 nm - SM - LC (PID ONS-XC-10G-C)



Note

If ONS-XC-10G-C XFP is used on GE_XP, 10GE_XP, GE_XPE, and 10GE_XPE cards on client port 1, the maximum temperature at which the system qualifies is +45 degree Celsius.

The client interfaces support the following multimode XFP using dual LC connectors and multi-mode fiber:

- XFP - OC-192/10GFC/10GE - 850 nm MM LC (PID ONS-XC-10G-SR-MM)

10.12.5 GE_XP, 10GE_XP, GE_XPE, and 10GE_XPE Card-Level Indicators

Table 10-41 describes the three card-level LEDs on the GE_XP, 10GE_XP, GE_XPE, and 10GE_XPE cards.

Table 10-41 GE_XP, 10GE_XP, GE_XPE, and 10GE_XPE Card-Level Indicators

Card-Level LED	Description
Red FAIL LED	The red FAIL LED indicates that the card's processor is not ready. This LED is on during reset. The FAIL LED flashes during the boot process. Replace the card if the red FAIL LED persists.
ACT LED Green (Active)	If the ACT LED is green, the card is operational (one or more ports active) and ready to carry traffic.
Amber SF LED	The amber SF LED indicates that a signal failure or condition such as LOS, LOF, or high BERs is present one or more of the card's ports. The amber SF LED is also on if the transmit and receive fibers are incorrectly connected. If the fibers are properly connected and the link is working, the light turns off.

10.12.6 GE_XP, 10GE_XP, GE_XPE, and 10GE_XPE Port-Level Indicators

Table 10-42 describes the port-level LEDs on the GE_XP, 10GE_XP, GE_XPE, and 10GE_XPE cards.

Table 10-42 GE_XP, 10GE_XP, GE_XPE, and 10GE_XPE Port-Level Indicators

Port-Level LED	Description
Port LEDs Green/Red/Amber/Off	<p>Green—The client port is either in service and receiving a recognized signal (that is, no signal fail), or Out of Service and Maintenance (OOS,MT or locked, maintenance) in which case the signal fail and alarms will be ignored.</p> <p>Red—The client port is in service but is receiving a signal fail (LOS).</p> <p>Amber—The port is provisioned and in a standby state.</p> <p>Off—The SFP is either not provisioned, out of service, not properly inserted, or the SFP hardware has failed.</p>
Green DWDM LED	<p>Green—The green DWDM LED indicates that the DWDM port is in service and receiving a recognized signal (that is, no signal fail), or Out of Service and Maintenance (OOS,MT or locked, maintenance) in which case the signal fail and alarms will be ignored.</p> <p>Red—The client port is in service but is receiving a signal fail (LOS).</p> <p>Amber—The port is provisioned and in a standby state.</p> <p>Off—The SFP is either not provisioned, out of service, not properly inserted, or the SFP hardware has failed.</p>

10.12.7 DWDM Trunk Interface

The GE_XP, 10GE_XP, GE_XPE, and 10GE_XPE cards have two 10 Gigabit Ethernet trunk ports operating at 10 Gigabit Ethernet (10.3125 Gbps) or 10 Gigabit Ethernet into OTU2 (nonstandard 11.0957 Gbps). The ports are compliant with ITU-T G.707, ITU-T G.709, and Telcordia GR-253-CORE standards. The ports are capable of carrying C-band and L-band wavelengths through insertion of DWDM XFPs. Forty channels are available in the 1550-nm C band 100-GHz ITU grid, and forty channels are available in the L band.

The maximum system reach in filterless applications without the use of optical amplification or regenerators is nominally rated at 23 dB over C-SMF fiber. This rating is not a product specification, but is given for informational purposes. It is subject to change.

10.12.8 Configuration Management

The GE_XP, 10GE_XP, GE_XPE, and 10GE_XPE cards support the following configuration management parameters:

- Port name—User-assigned text string.
- Admin State/Service State—Administrative and service states to manage and view port status.
- MTU—Provisionable maximum transfer unit (MTU) to set the maximum number of bytes per frames accepted on the port.
- Mode—Provisional port mode, either Autonegotiation or the port speed.
- Flow Control—Flow control according to IEEE 802.1x pause frame specification can be enabled or disabled for TX and RX ports.
- Bandwidth—Provisionable maximum bandwidth allowed for the port.
- Ingress CoS—Assigns a CoS value to the port from 0 (highest) to 7 (lowest) and accepts CoS of incoming frames.
- Egress QoS—Defines the QoS capabilities at the egress port.
- NIM—Defines the port network interface management type based on Metro Ethernet Forum specifications. Ports can be defined as UNI or NNI.
- MAC Learning—MAC address learning to facilitate switch processing.
- VLAN tagging provided according to the IEEE 802.1Q standard.

**Note**

When the GE_XP, 10GE_XP, GE_XPE, and 10GE_XPE cards are provisioned in a MXP or TXP mode, only the following parameters are available: Port Name, State, MTU, Mode, Flow control, and Bandwidth.

10.12.9 Security

GE_XP, 10GE_XP, GE_XPE, and 10GE_XPE card ports can be provisioned to block traffic from a user-defined set of MAC addresses. The remaining traffic is normally switched. You can manually specify the set of blocked MAC addresses for each port. Each port of the card can receive traffic from a limited predefined set of MAC addresses. The remaining traffic will be dropped. This capability is a subset of the Cisco IOS “Port Security” feature.

10.12.10 Card Protection

The following section describes various card protection schemes available for the GE_XP, 10GE_XP, GE_XPE, and 10GE_XPE cards.

10.12.10.1 1+1 Protection

1+1 protection of GE_XP, 10GE_XP, GE_XPE, and 10GE_XPE cards is provided in the Layer 2 (L2) card mode to protect against client port and card failure.

1+1 protection is supported in both single shelf and multishelf setup. This means that the working card can be in one shelf and the protect card can be in another shelf of a multishelf setup. Communication between the two cards is across 10 Gigabit Ethernet interconnection interface using Ethernet packets. The Inter link (ILK) trunk or internal patchcord must be provisioned on both the cards. This link is used to transmit protection switching messages and data. For information on how to provision ILK or internal patchcords, refer *Cisco ONS 15454 DWDM Procedure Guide*.



Note

With 1+1 protection mechanisms, the switch time of a copper SFP is 1 second.

With 1+1 protection, ports on the protect card can be assigned to protect the corresponding ports on the working card. A working card must be paired with a protect card of the same type and number of ports. The protection takes place on the port level, and any number of ports on the protect card can be assigned to protect the corresponding ports on the working card.

To make the 1+1 protection scheme fully redundant, enable L2 protection for the entire VLAN ring. This enables Fast Automatic Protection Switch (FAPS). The VLAN configured on the 1+1 port must be configured as protected SVLAN. For information on how to enable FAPS, see *Cisco ONS 15454 DWDM Procedure Guide*.

1+1 protection can be either revertive or nonrevertive. With nonrevertive 1+1 protection, when a failure occurs and the signal switches from the working card to the protect card, the signal remains on the protect card until it is manually changed. Revertive 1+1 protection automatically switches the signal back to the working card when the working card comes back online. 1+1 protection uses trunk ports to send control traffic between working and protect cards. This trunk port connection is known as ILK trunk ports and can be provisioned via CTC. For information on how to provision an ILK link, see “DLP-G460 Provision an ILK Link” in the *Cisco ONS 15454 DWDM Procedure Guide*.

The standby port can be configured to turn ON or OFF but the traffic coming to and from the standby port will be down. If the laser is ON at the standby port, the other end port (where traffic originates) will not be down in a parallel connection. Traffic is blocked on the standby port.

1+1 protection is bidirectional and nonrevertive by default; revertive switching can be provisioned using CTC. For information on how to provision the cards, refer to the *Cisco ONS 15454 DWDM Procedure Guide*.

10.12.10.2 Y-Cable Protection

The GE_XP and GE_XPE cards support Y-cable protection when they are provisioned in 10 Gigabit Ethernet or 20 Gigabit Ethernet MXP card mode. The 10GE_XP and 10GE_XPE cards support Y-cable protection when they are provisioned in 10GE TXP card mode. Two cards can be joined in a Y-cable protection group with one card assigned as the working card and the other defined as the protection card. This protection mechanism provides redundant bidirectional paths. See the “[10.19.1 Y-Cable Protection](#)” section on page 10-140 for more detailed information. The Y-cable protection mechanism is

provisionable and can be set ON or OFF (OFF is the default mode). When a signal fault is detected (LOS, LOF, SD, or SF on the DWDM receiver port in the case of ITU-T G.709 mode) the protection mechanism software automatically switches between paths. Y-cable protection also supports revertive and nonrevertive mode.

10.12.10.3 Layer 2 Over DWDM Protection

When the GE_XP, 10GE_XP, GE_XPE, or 10GE_XPE cards are in L2-over-DWDM card mode, protection is handled by the hardware at the Layer 1 and Layer 2 levels. Fault detection and failure propagation is communicated through the ITU-T G.709 frame overhead bytes. For protected VLANs, traffic is flooded around the 10 Gigabit Ethernet DWDM ring. To set up the Layer 2 protection, you identify a node and the GE_XP, 10GE_XP, GE_XPE, or 10GE_XPE port that is to serve as the master node and port for the VLAN ring on the card view Provisioning > Protection tab. If a failure occurs, the node and port are responsible for opening and closing VLAN loops.



Note

The Forced option in the Protection drop-down list converts all the SVLANs to protected SVLANs irrespective of the SVLAN protection configuration in the SVLAN database. This is applicable to a point-to-point linear topology. The SVLAN protection must be forced to move all SVLANs, including protected and unprotected SVLANs, to the protect path irrespective of provisioned SVLAN attributes.

A FAPS switchover happens in the following failure scenarios:

- DWDM line failures caused by a fiber cut
- Unidirectional failure in the DWDM network caused by a fiber cut
- Fiber pull on the master card trunk port followed by a hard reset on the master card
- Hard reset on the master card
- Hard reset on the slave card
- An OTN failure is detected (LOS, OTUK-LOF, OTUK-LOM, OTUK-SF, or OTUK-BDI on the DWDM receiver port in the case of ITU-T G.709 mode)
- Trunk ports are moved to OOS,DSBLD (Locked,disabled) state
- Improper removal of XFPs

A FAPS switchover does not happen in the following scenarios:

- Slave card trunk port in OOS,DSBLD (Locked,disabled) state followed by a hard reset of the slave card
- OTN alarms raised on the slave card trunk port followed by a hard reset of the slave card

10.12.11 IGMP Snooping

As networks increase in size, multicast routing becomes critically important as a means to determine which segments require multicast traffic and which do not. IP multicasting allows IP traffic to be propagated from one source to a number of destinations, or from many sources to many destinations. Rather than sending one packet to each destination, one packet is sent to the multicast group identified by a single IP destination group address. GE_XP, 10GE_XP, GE_XPE, and 10GE_XPE cards can learn up to a maximum of 1024 multicast groups. This includes groups on all the VLANs.

Internet Group Management Protocol (IGMP) snooping restricts the flooding of multicast traffic by forwarding multicast traffic to those interfaces where a multicast device is present.

When the GE_XP, 10GE_XP, GE_XPE, or 10GE_XPE card receives an IGMP leave group message from a host, it removes the host port from the multicast forwarding table after generating group specific queries to ensure that no other hosts interested in traffic for the particular group are present on that port. Even in the absence of any “leave” message, the cards have a timeout mechanism to update the group table with the latest information. After a card relays IGMP queries from the multicast router, it deletes entries periodically if it does not receive any IGMP membership reports from the multicast clients.

In a multicast router, general queries are sent on a VLAN when Protocol Independent Multicast (PIM) is enabled on the VLAN. The GE_XP, 10GE_XP, GE_XPE, or 10GE_XPE card forwards queries to all ports belonging to the VLAN. All hosts interested in this multicast traffic send Join requests and are added to the forwarding table entry. The Join requests are forwarded only to router ports. By default, these router ports are learned dynamically. However, they can also be statically configured at the port level in which case the static configuration overrides dynamic learning.

For information on interaction of IGMP with other protocols, see the [10.12.2 Protocol Compatibility list](#).

10.12.11.1 IGMP Snooping Guidelines and Restrictions

The following guidelines and restrictions apply to IGMP snooping on GE_XP, 10GE_XP, GE_XPE, and 10GE_XPE cards:

- IGMP snooping V2 is supported as specified in RFC 4541.
- IGMP snooping V3 is not supported and the packets are flooded in the SVLAN.
- Layer 2 multicast groups learned through IGMP snooping are dynamic.
- GE_XP and 10GE_XP cards support IGMP snooping on 128 stacked VLANs and GE_XPE and 10GE_XPE cards support up to 256 stacked VLANs that are enabled.
- IGMP snooping can be configured per SVLAN or CVLAN. By default, IGMP snooping is disabled on all SVLANs and CVLANs.
- IGMP snooping on CVLAN is enabled only when:
 - MVR is enabled.
 - UNI ports are in selective add and selective translate modes. For each UNI port, a CVLAN must be specified for which IGMP snooping is to be enabled.
- IGMP snooping can be enabled only on one CVLAN per port. If you enable IGMP snooping on CVLAN, you cannot enable IGMP snooping on the associated SVLAN and vice versa. The number of VLANs that can be enabled for IGMP snooping cannot exceed 128.
- When IGMP snooping is enabled on double-tagged packets, CVLAN has to be the same on all ports attached to the same SVLAN.
- When IGMP snooping is working with the Fast Automatic Protection Switch (FAPS) in a ring-based setup, it is advisable to configure all NNI ports as static router ports. This minimizes the multicast traffic hit when a FAPS switchover occurs.

The following conditions are raised from IGMP snooping at the card:

- MCAST-MAC-TABLE-FULL—This condition is raised when the multicast table is full and a new join request is received. This table is cleared when at least one entry gets cleared from the multicast table after the alarm is raised.
- MCAST-MAC-ALIASING—This condition is raised when there are multiple L3 addresses that map to the same L2 address in a VLAN. This is a transient condition.

For more information on severity level of these conditions and procedure to clear these alarms, refer to the *Cisco ONS 15454 Troubleshooting Guide*.

10.12.11.2 Fast-Leave Processing

**Note**

Fast-Leave processing is also known as Immediate-Leave.

IGMP snooping Fast-Leave processing allows the GE_XP, 10GE_XP, GE_XPE, or 10GE_XPE to remove an interface that sends a leave message from the forwarding table without first sending group specific queries to the interface. When you enable IGMP Fast-Leave processing, the card immediately removes a port from the IP multicast group when it detects an IGMP, version 2 (IGMPv2) leave message on that port.

10.12.11.3 Static Router Port Configuration

Multicast-capable ports are added to the forwarding table for every IP multicast entry. The card learns of such ports through the PIM method.

10.12.11.4 Report Suppression

Report suppression is used to avoid a storm of responses to an IGMP query. When this feature is enabled, a single IGMP report is sent to each multicast group in response to a single query. Whenever an IGMP snooping report is received, report suppression happens if the report suppression timer is running. The Report suppression timer is started when the first report is received for a general query. Then this time is set to the response time specified in general query.

10.12.11.5 IGMP Statistics and Counters

An entry in a counter contains multicasting statistical information for the IGMP snooping capable GE_XP, 10GE_XP, GE_XPE, or 10GE_XPE card. It provides statistical information about IGMP messages that have been transmitted and received. IGMP statistics and counters can be viewed via CTC from the Performance > Ether Ports > Statistics tab.

This information can be stored in the following counters:

- cisTxGeneralQueries—Number of general queries transmitted through an interface.
- cisTxGroupSpecificQueries—Total group specific queries transmitted through an interface.
- cisTxReports—Total membership reports transmitted through an interface.
- cisTxLeaves—Total Leave messages transmitted through an interface.
- cisRxGeneralQueries—Total general queries received at an interface.
- cisRxGroupSpecificQueries—Total Group Specific Queries received at an interface.
- cisRxReports—Total Membership Reports received at an interface.
- cisRxLeaves—Total Leave messages received at an interface.
- cisRxValidPackets—Total valid IGMP packets received at an interface.
- cisRxInvalidPackets—Total number of packets that are not valid IGMP messages received at an interface.

10.12.12 Multicast VLAN Registration

Multicast VLAN Registration (MVR) is designed for applications using wide-scale deployment of multicast traffic across an Ethernet-ring-based service provider network (for example, the broadcast of multiple television channels over a service-provider network). MVR allows a subscriber on a port to subscribe and unsubscribe to a multicast stream on the network-wide multicast VLAN. It allows the single multicast VLAN to be shared in the network while subscribers remain in separate VLANs. MVR provides the ability to continuously send multicast streams in the multicast VLAN, but to isolate the streams from the subscriber VLANs for bandwidth and security reasons.

MVR assumes that subscriber ports subscribe and unsubscribe (“Join” and “Leave”) these multicast streams by sending out IGMP Join and Leave messages. These messages can originate from an IGMP version-2-compatible host with an Ethernet connection. MVR operates on the underlying mechanism of IGMP snooping. MVR works only when IGMP snooping is enabled.

The card identifies the MVR IP multicast streams and their associated MAC addresses in the card forwarding table, intercepts the IGMP messages, and modifies the forwarding table to include or remove the subscriber as a receiver of the multicast stream, even though the receivers is in a different VLAN than the source. This forwarding behavior selectively allows traffic to cross between different VLANs.



Note

When MVR is configured, the port facing the router must be configured as NNI in order to allow the router to generate or send multicast stream to the host with the SVLAN. If router port is configured as UNI, the MVR will not work properly.

10.12.13 MAC Address Learning

The GE_XPE and 10 GE_XPE cards support 32K MAC addresses. MAC address learning can be enabled or disabled per SVLAN on GE_XPE and 10 GE_XPE cards. The cards learn the MAC address of packets they receive on each port and add the MAC address and its associated port number to the MAC address learning table. As stations are added or removed from the network, the GE_XPE and 10 GE_XPE cards update the MAC address learning table, adding new dynamic addresses and aging out those that are currently not in use.

MAC address learning can be enabled or disabled per SVLAN. When the configuration is changed from enable to disable, all the related MAC addresses are cleared. The following conditions apply:

- If MAC address learning is enabled on per port basis, the MAC address learning is not enabled on all VLANs, but only on VLANs that have MAC address learning enabled.
- If per port MAC address learning is disabled then the MAC address learning is disabled on all VLANs, even if it is enabled on some of the VLAN supported by the port.
- If the per port MAC address learning is configured on GE-XP and 10 GE-XP cards, before upgrading to GE-XPE or 10 GE-XPE cards, enable MAC address learning per SVLAN. Failing to do so disables MAC address learning.

10.12.14 MAC Address Retrieval

MAC addresses learned can be retrieved or cleared on GE_XP, 10GE_XP, GE_XPE, and 10GE_XPE cards provisioned in L2-over-DWDM mode. The MAC addresses can be retrieved using the CTC or TL1 interface.

GE_XPE and 10GE_XPE cards support 32K MAC addresses and GE_XP and 10GE_XP cards support 16K MAC addresses. To avoid delay in processing requests, the learned MAC addresses are retrieved using an SVLAN range. The valid SVLAN range is from 1 to 4093.

The MAC addresses of the GE_XP, 10GE_XP, GE_XPE, and 10GE_XPE cards can also be retrieved. The card MAC addresses are static and are used for troubleshooting activities. One MAC address is assigned to each client, trunk, and CPU ports of the GE_XP, 10GE_XP, GE_XPE, or 10GE_XPE card. These internal MAC addresses can be used to determine if the packets received on the far-end node are generated by GE_XP, 10GE_XP, GE_XPE, and 10GE_XPE cards.

For MAC address retrieval, the following conditions apply:

- The cards must be provisioned in L2-over-DWDM mode.
- MAC address learning must be enabled per SVLAN on GE_XPE or 10 GE_XPE cards.
- MAC address learning must be enabled per port on GE_XP or 10 GE_XP cards.

For information on how to retrieve or clear MAC addresses learned, refer to the “Provision Transponder and Muxponder Cards” chapter in the *Cisco ONS 15454 DWDM Procedure Guide*.

10.12.15 Link Integrity

The GE_XP, 10GE_XP, GE_XPE, and 10GE_XPE card support end-to-end Ethernet link integrity. This capability is integral to providing an Ethernet private line service and correct operation of Layer 2 and Layer 3 protocols on the attached Ethernet devices.

The link integrity feature propagates a trunk fault on all the affected SVLAN circuits in order to squelch the far end client interface. Ethernet-Advanced IP Services (E-AIS) packets are generated on a per-port/SVLAN basis. An E-AIS format is compliant with ITU Y.1731.

**Note**

E-AIS packets are marked with a CoS value of 7 (also called .1p bits). Ensure that the network is not overloaded and there is sufficient bandwidth for this queue in order to avoid packet drops.

When link integrity is enabled on a per-port SVLAN basis, E-AIS packets are generated when the following alarms are raised;

- LOS-P
- OTUKLOF/LOM
- SIGLOSS
- SYNCHLOSS
- OOS
- PPM not present

When link integrity is enabled, GE_XP and 10 GE_XP card supports up to 128 SVLANs and GE_XPE, 10 GE_XPE can support up to 256 SVLANs.

10.12.16 Ingress CoS

Ingress CoS functionality enables differentiated services across the GE_XPE and 10GE_XPE cards. A wide range of networking requirements can be provisioned by specifying the class of service applicable to each transmitted traffic.

When a CVLAN is configured as ingress CoS, the per-port settings are not considered. A maximum of 128 CVLAN and CoS relationships can be configured.

10.12.17 CVLAN Rate Limiting

CVLAN rate limiting is supported on GE_XP, 10GE_XP, GE_XPE, and 10GE_XPE cards. CVLAN rate limiting is supported for QinQ service in selective add mode. The following limitations and restrictions apply to CVLAN rate limiting:

- CVLAN rate limiting is not supported for the following service types:
 - Selective translate mode
 - Transparent mode
 - Selective double add mode
 - Selective translate add mode
 - Untagged packets
 - CVLAN range
 - Services associated with the channel group
- CVLAN rate limiting and SVLAN rate limiting cannot be applied to the same service instance.
- Pseudo-IOS command line interface (PCLI) is not supported for CVLAN rate limiting.
- A VLAN profile with Link Integrity option enabled cannot be used to perform CVLAN rate limiting.
- On GE_XP and 10 GE_XP cards, CVLAN rate limiting can be applied to up to 128 services. However, the number of provisionable CVLAN rate limiting service instances is equal to 192 minus the number of SVLAN rate limiting service instances present on the card (subject to a minimum of 64 CVLAN rate limiting service instances).
- On GE_XPE and 10 GE_XPE cards, CVLAN rate limiting can be applied to up to 256 services. However, the number of provisionable CVLAN rate limiting service instances is equal to 384 minus the number of SVLAN rate limiting service instances present on the card (subject to a minimum of 128 CVLAN rate limiting service instances).

10.12.18 DSCP to CoS Mapping

DSCP to CoS mapping can be configured for each port. You can configure the CoS of the outer VLAN based on the incoming DSCP bits. This feature is supported only on GE_XPE and 10GE_XPE cards. PCLI is not supported for DSCP to CoS mapping.

DSCP to CoS mapping is supported for the following service types:

- Selective add mode
- Selective translate mode
- Transparent mode
- Selective double add mode
- Selective translate add mode
- Untagged packets
- CVLAN range

- Services associated with the channel group

10.12.19 Link Aggregation Control Protocol

Link Aggregation Control Protocol (LACP) is part of the IEEE802.3ad standard that allows you to bundle several physical ports together to form a single logical channel. LACP allows a network device such as a switch to negotiate an automatic bundling of links by sending LACP packets to the peer device.

LACP allows you to form a single Layer 2 link automatically from two or more Ethernet links. This protocol ensures that both ends of the Ethernet link are functional and agree to be members of the aggregation group before the link is added to the group. LACP must be enabled at both ends of the link to be operational.

For more information on LACP, refer to the IEEE802.3ad standard. For information on interaction of LACP with other protocols, see the [10.12.2 Protocol Compatibility list](#).

10.12.19.1 Advantages of LACP

LACP provides the following advantages:

- High-speed network that transfers more data than any single port or device.
- High reliability and redundancy. If a port fails, traffic continues on the remaining ports.
- Hashing algorithm that allows to apply load balancing policies on the bundled ports.

10.12.19.2 Functions of LACP

LACP performs the following functions in the system:

- Maintains configuration information to control aggregation.
- Exchanges configuration information with other peer devices.
- Attaches or detaches ports from the link aggregation group based on the exchanged configuration information.
- Enables data flow when both sides of the aggregation group are synchronized.

10.12.19.3 Modes of LACP

LACP can be configured in the following modes:

- On — Default. In this mode, the ports do not exchange LACP packets with the partner ports.
- Active — In this mode, the ports send LACP packets at regular intervals to the partner ports.
- Passive — In this mode, the ports do not send LACP packets until the partner sends LACP packets. After receiving the LACP packets from the partner ports, the ports send LACP packets.

10.12.19.4 Parameters of LACP

LACP uses the following parameters to control aggregation:

- System Identifier—A unique identification assigned to each system. It is the concatenation of the system priority and a globally administered individual MAC address.

- Port Identification—A unique identifier for each physical port in the system. It is the concatenation of the port priority and the port number.
- Port Capability Identification—An integer, called a key, that identifies the capability of one port to aggregate with another port. There are two types of keys:
 - Administrative key—The network administrator configures this key.
 - Operational key—The LACP assigns this key to a port, based on its aggregation capability.
- Aggregation Identifier—A unique integer that is assigned to each aggregator and is used for identification within the system.

10.12.19.5 Unicast Hashing Schemes

LACP supports the following unicast hashing schemes:

- Ucast SA VLAN Incoming Port
- Ucast DA VLAN Incoming Port
- Ucast SA DA VLAN Incoming port
- Ucast Src IP TCP UDP
- Ucast Dst IP TCP UDP
- Ucast Src Dst IP TCP UDP



Note

Unicast hashing schemes apply to unicast traffic streams only when the destination MAC address is already learned by the card. Hence, MAC learning must be enabled to support load balancing as per the configured hashing scheme. If the destination MAC address is not learned, the hashing scheme is Ucast Src Dst IP TCP UDP.

10.12.19.6 Supported LACP Features

The GE_XP, 10GE_XP, GE_XPE, and 10GE_XPE cards support the following LACP features as per the IEEE802.3ad standard:

- *DLP-G611 Create a Channel Group Using CTC*
- *DLP-G612 Modify the Parameters of the Channel Group Using CTC*
- *DLP-G613 Add or Remove Ports to or from an Existing Channel Group Using CTC*
- *DLP-G614 Delete a Channel Group Using CTC*

See the *Cisco ONS 15454 DWDM Procedure Guide* for information on these procedures.

10.12.19.7 LACP Limitations and Restrictions

The LACP on the GE_XP, 10GE_XP, GE_XPE, and 10GE_XPE cards has the following limitations and restrictions:

- Hot standby link state is not supported on the channel group.
- Marker protocol generator is not supported.
- ALS cannot be configured on the channel group.
- Loopback configuration cannot be applied on the channel group.

10.12.20 Ethernet Connectivity Fault Management

Ethernet Connectivity Fault Management (CFM) is part of the IEEE 802.1ag standard. The Ethernet CFM is an end-to-end per service instance that supports the Ethernet layer Operations, Administration, and Management (OAM) protocol. It includes proactive connectivity monitoring, link trace on a per service basis, fault verification, and fault isolation for large Ethernet metropolitan-area networks (MANs) and WANs.

CFM is disabled on the card by default. CFM is enabled on all the ports by default.

For more information on CFM, refer to the IEEE 802.1ag standard. For information on interaction of CFM with other protocols, see the [10.12.2 Protocol Compatibility list](#). The following sections contain conceptual information about Ethernet CFM.

10.12.20.1 Maintenance Domain

A maintenance domain is an administrative domain that manages and administers a network. You can assign a unique maintenance level (from 0 to 7) to define the hierarchical relationship between domains. The larger the domain, the higher the maintenance level for that domain. For example, a service provider domain would be larger than an operator domain and might have a maintenance level of 6, while the operator domain maintenance level would be 3 or 4.

Maintenance domains cannot intersect or overlap because that would require more than one entity to manage it, which is not allowed. Domains can touch or nest if the outer domain has a higher maintenance level than the nested domain. Maintenance levels of nesting domains must be communicated among the administrating organizations. For example, one approach would be to have the service provider assign maintenance levels to operators.

The CFM protocol supports up to eight maintenance domains on GE_XP, 10GE_XP, GE_XPE, and 10GE_XPE cards.

10.12.20.2 Maintenance Association

A maintenance association identifies a service within the maintenance domain. You can have any number of maintenance associations within each maintenance domain. The CFM protocol supports up to 1500 maintenance associations on GE_XP, 10GE_XP, GE_XPE, and 10GE_XPE cards.

**Note**

Each maintenance association is mapped to a maintenance domain. This mapping is done to configure a Maintenance End Point (MEP). The CFM protocol supports up to 1000 mappings on GE_XP, 10GE_XP, GE_XPE, and 10GE_XPE cards.

10.12.20.3 Maintenance End Points

Maintenance End Points (MEPs) reside at the edge of the maintenance domain and are active elements of the Ethernet CFM. MEPs transmit Continuity Check messages at periodic intervals and receive similar messages from other MEPs within a domain. MEPs also transmit Loopback and Traceroute messages at the request of the administrator. MEPs confine CFM messages within the boundary of a maintenance domain through the maintenance level. There are two types of MEPs:

- Up (Inwards, towards the bridge)
- Down (Outwards, towards the wire).

You can create up to 255 MEPs and MIPs together on GE_XP and 10GE_XP cards. You can create up to 500 MEPs and MIPs together on GE_XPE and 10GE_XPE cards.

The MEP continuity check database (CCDB) stores information that is received from other MEPs in the maintenance domain. The card can store up to 4000 MEP CCDB entries.

10.12.20.4 Maintenance Intermediate Points

Maintenance Intermediate Points (MIPs) are internal to the maintenance domain and are passive elements of the Ethernet CFM. They store information received from MEPs and respond to Linktrace and Loopback CFM messages. MIPs forward CFM frames received from MEPs and other MIPs, drop all CFM frames at a lower level, and forward all CFM frames at a higher level.

You can create up to 255 MEPs and MIPs together on GE_XP and 10GE_XP cards. You can create up to 500 MEPs and MIPs together on GE_XPE and 10GE_XPE cards.

The MIP CCDB maintains the information received for all MEPs in the maintenance domain. The card can store up to 4000 MIP CCDB entries.

10.12.20.5 CFM Messages

The Ethernet CFM on GE_XP, 10GE_XP, GE_XPE, and 10GE_XPE cards supports the following messages:

- Continuity Check—These messages are exchanged periodically among MEPs. They allow MEPs to discover other MEPs within a domain and allow MIPs to discover MEPs. These messages are confined to a domain.
- Loopback—These messages are unicast messages that a MEP transmits, at the request of an administrator, to verify connectivity to a specific maintenance point. A reply to a loopback message indicates whether a destination is reachable.
- Traceroute—These messages are multicast messages that a MEP transmits, at the request of an administrator, to track the path to a destination MEP.

10.12.20.6 Supported CFM Features

The GE_XP, 10GE_XP, GE_XPE, and 10GE_XPE cards support the following Ethernet CFM features as per the IEEE 802.1ag standard:

- *DLP-G621 Enable or Disable CFM on the Card Using CTC*
- *DLP-G622 Enable or Disable CFM for Each Port Using CTC*
- *DLP-G623 Create a Maintenance Domain Profile Using CTC*
- *DLP-G625 Create a Maintenance Association Profile Using CTC*
- *DLP-G628 Map a Maintenance Association Profile to a Maintenance Domain Profile Using CTC*
- *DLP-G629 Create a MEP Using CTC*
- *DLP-G631 Create a MIP Using CTC*
- *DLP-G633 Ping MEP Using CTC*
- *DLP-G634 Traceroute MEP Using CTC*

See the *Cisco ONS 15454 DWDM Procedure Guide* for information on these procedures.

10.12.20.7 CFM Limitations and Restrictions

The CFM on the GE_XP, 10GE_XP, GE_XPE, and 10GE_XPE cards has the following limitations and restrictions:

- CFM is not supported on channel groups.
- CFM is not enabled on protected ports running REP, FAPS, and 1+1.
- Y.1731 enhancements including AIS, LCK, and performance monitoring messages along with CFM are not supported.
- IEEE CFM MIB is not supported.
- L1 and CFM are mutually exclusive on a SVLAN because LI and CFM use the same MAC address.
- MAC security and CFM are mutually exclusive on the card due to hardware resource constraints.

10.12.21 Ethernet OAM

The Ethernet OAM protocol is part of the IEEE 802.3ah standard and is used for installing, monitoring, and troubleshooting Ethernet MANs and Ethernet WANs. This protocol relies on an optional sublayer in the data link layer of the OSI model. The Ethernet OAM protocol was developed for Ethernet in the First Mile (EFM) applications. The terms Ethernet OAM and EFM are interchangeably used and both mean the same.

Normal link operation does not require Ethernet OAM. You can implement Ethernet OAM on any full-duplex point-to-point or emulated point-to-point Ethernet link for a network or part of a network (specified interfaces). OAM frames, called OAM Protocol Data Units (OAM PDUs), use the slow protocol destination MAC address 0180.c200.0002. OAM PDUs are intercepted by the MAC sublayer and cannot propagate beyond a single hop within an Ethernet network.

Ethernet OAM is disabled on all interfaces by default. When Ethernet OAM is enabled on an interface, link monitoring is automatically turned on.

For more information on Ethernet OAM protocol, refer to IEEE 802.3ah standard. For information on interaction of Ethernet OAM with other protocols, see the [10.12.2 Protocol Compatibility list](#).

10.12.21.1 Components of the Ethernet OAM

Ethernet OAM consists of two major components, the OAM Client and the OAM Sublayer.

10.12.21.1.1 OAM Client

The OAM client establishes and manages the Ethernet OAM on a link. The OAM client also enables and configures the OAM sublayer. During the OAM discovery phase, the OAM client monitors the OAM PDUs received from the remote peer and enables OAM functionality. After the discovery phase, the OAM client manages the rules of response to OAM PDUs and the OAM remote loopback mode.

10.12.21.1.2 OAM Sublayer

The OAM sublayer presents two standard IEEE 802.3 MAC service interfaces:

- One interface facing toward the superior sublayers, which include the MAC client (or link aggregation).
- Other interface facing toward the subordinate MAC control sublayer.

The OAM sublayer provides a dedicated interface for passing OAM control information and OAM PDUs to and from the client.

10.12.21.2 Benefits of the Ethernet OAM

Ethernet OAM provides the following benefits:

- Competitive advantage for service providers
- Standardized mechanism to monitor the health of a link and perform diagnostics

10.12.21.3 Features of the Ethernet OAM

The Ethernet OAM protocol has the following OAM features:

- **Discovery**—Identifies devices in the network and their OAM capabilities. The Discovery feature uses periodic OAM PDUs to advertise the OAM mode, configuration, and capabilities. An optional phase allows the local station to accept or reject the configuration of the peer OAM entity.
- **Link Monitoring**—Detects and indicates link faults under a variety of conditions. It uses the event notification OAM PDU to notify the remote OAM device when it detects problems on the link.
- **Remote Failure Indication**—Allows an OAM entity to convey the failure conditions to its peer through specific flags in the OAM PDU.
- **Remote Loopback**—Ensures link quality with a remote peer during installation or troubleshooting.

10.12.21.4 Ethernet OAM Supported Features

The GE_XP, 10GE_XP, GE_XPE, and 10GE_XPE cards support the following Ethernet OAM features as per the IEEE 802.3ah standard:

- *DLP-G639 Enable or Disable EFM for Each Port Using CTC*
- *DLP-G640 Configure EFM Parameters Using CTC*
- *DLP-G641 Configure EFM Link Monitoring Parameters Using CTC*
- *DLP-G642 Enable Remote Loopback for Each Port Using CTC*

See the *Cisco ONS 15454 DWDM Procedure Guide* for information on these procedures.

10.12.21.5 Ethernet OAM Limitations and Restrictions

The Ethernet OAM on the GE_XP, 10GE_XP, GE_XPE, and 10GE_XPE cards has the following limitations and restrictions:

- CFM, REP, link integrity, LACP, FAPS, IGMP on SVLAN and L2 1+1 protection are not supported with EFM.
- IEEE EFM MIB is not supported.
- EFM cannot be enabled or disabled at the card level.
- Unidirectional functionality is not supported.
- Errored Symbol Period, Rx CRC errors, Tx CRC errors are not supported.
- OAM PDUs are limited to 1 frame per second.
- Dying Gasp and critical events are not supported.

**Note**

Dying Gasp RFI is not generated on GE_XP, 10GE_XP, GE_XPE, and 10GE_XPE cards. However, if the peer device sends a dying gasp RFI, the card detects it and raises an alarm.

10.12.22 Resilient Ethernet Protocol

The Resilient Ethernet Protocol (REP) is a protocol used to control network loops, handle link failures, and improve convergence time.

REP performs the following tasks:

- Controls a group of ports connected in a segment.
- Ensures that the segment does not create any bridging loops.
- Responds to link failures within the segment.
- Supports VLAN load balancing.

For information on interaction of REP with other protocols, see the [10.12.2 Protocol Compatibility list](#).

10.12.22.1 REP Segments

A REP segment is a chain of ports connected to each other and configured with a segment ID. Each segment consists of regular segment ports and two edge ports. A GE_XP, 10GE_XP, GE_XPE, or 10GE_XPE card can have up to 2 ports that belong to the same segment, and each segment port can have only one external neighbor port.

A segment protects only against a single link failure. Any more failures within the segment result in loss of connectivity.

10.12.22.2 Characteristics of REP Segments

REP segments have the following characteristics:

- If all the ports in the segment are operational, one port blocks traffic for each VLAN. If VLAN load balancing is configured, two ports in the segment control the blocked state of VLANs.
- If any port in the segment is not operational, all the other operational ports forward traffic on all VLANs to ensure connectivity.
- In case of a link failure, the alternate ports are immediately unblocked. When the failed link comes up, a logically blocked port per VLAN is selected with minimal disruption to the network.

10.12.22.3 REP Port States

Ports in REP segments take one of three roles or states: Failed, Open, or Alternate.

- A port configured as a regular segment port starts as a failed port.
- When the neighbor adjacencies are determined, the port transitions to the alternate port state, blocking all the VLANs on the interface. Blocked port negotiations occur and when the segment settles, one blocked port remains in the alternate role and all the other ports become open ports.
- When a failure occurs in a link, all the ports move to the failed state. When the alternate port receives the failure notification, it changes to the open state, forwarding all VLANs.

10.12.22.4 Link Adjacency

Each segment port creates an adjacency with its immediate neighbor. Link failures are detected and acted upon locally. If a port detects a problem with its neighbor, the port declares itself non-operational and REP converges to a new topology.

REP Link Status Layer (LSL) detects its neighbor port and establishes connectivity within the segment. All VLANs are blocked on an interface until the neighbor port is identified. After the neighbor port is identified, REP determines the neighbor port that must be the alternate port and the ports that must forward traffic.

Each port in a segment has a unique port ID. When a segment port starts, the LSL layer sends packets that include the segment ID and the port ID.

A segment port does not become operational if the following conditions are satisfied:

- No neighbor port has the same segment ID or more than one neighbor port has the same segment ID.
- The neighbor port does not acknowledge the local port as a peer.

10.12.22.5 Fast Reconvergence

REP runs on a physical link and not on per VLAN. Only one hello message is required for all VLANs that reduces the load on the protocol.

REP Hardware Flood Layer (HFL) is a transmission mechanism that floods packets in hardware on an admin VLAN. HFL avoids the delay that is caused by relaying messages in software. HFL is used for fast reconvergence in the order of 50 to 200 milliseconds.

10.12.22.6 VLAN Load Balancing

You must configure two edge ports in the segment for VLAN load balancing. One edge port in the REP segment acts as the primary edge port; the other edge port as the secondary edge port. The primary edge port always participates in VLAN load balancing in the segment. VLAN load balancing is achieved by blocking certain VLANs at a configured alternate port and all the other VLANs at the primary edge port.

10.12.22.7 REP Configuration Sequence

You must perform the following tasks in sequence to configure REP:

- Configure the REP administrative VLAN or use the default VLAN 1. The range of REP admin VLAN is 1 to 4093. VLAN 4094 is not allowed.
- Add ports to the segment in interface configuration mode.
- Enable REP on ports and assign a segment ID to it. REP is disabled on all ports by default. The range of segment ID is 1 to 1024.
- Configure two edge ports in the segment; one port as the primary edge port and the other as the secondary edge port.
- If you configure two ports in a segment as the primary edge port, for example, ports on different switches, REP selects one of the ports to serve as the primary edge port based on port priority. The Primary option is enabled only on edge ports.
- Configure the primary edge port to send segment topology change notifications (STCNs) and VLAN load balancing to another port or to other segments. STCNs and VLAN load balancing configurations are enabled only for edge ports.

**Note**

A port can belong to only one segment. Only two ports can belong to the same segment. Both the ports must be either regular ports or edge ports. However, if the No-neighbor port is configured, one port can be an edge port and another port can be a regular port.

10.12.22.8 REP Supported Interfaces

REP supports the following interfaces:

- REP is supported on client (UNI) and trunk (NNI) ports.
- Enabling REP on client ports allows protection at the access or aggregation layer when the cards are connected to the L2 network.
- Enabling REP on trunk ports allows protection at the edge layer when the cards are connected in a ring.

10.12.22.9 REP Limitations and Restrictions

The REP on the GE_XP, 10GE_XP, GE_XPE, and 10GE_XPE cards has the following limitations and restrictions:

- Fast re-convergence and VLAN load balancing are not supported on UNI ports in transparent mode.
- Native VLAN is not supported.
- CFM, EFM, link integrity, LACP, FAPS, and L2 1+1 protection are not supported on ports that are configured as part of REP segment and vice versa.
- When a node installed with GE_XP, GE_XPE, 10GE_XP, or 10GE_XPE cards configured with REP or LACP is upgraded, traffic loss may occur. This traffic loss is due to reconvergence when the cards soft reset during the upgrade process.
- NNI ports cannot be configured as the primary edge port or blocking port at the access or aggregation layer.
- Only three REP segments can be configured on GE_XP, 10GE_XP, GE_XPE, and 10GE_XPE cards.
- Consider the following configuration:

More than one REP closed segment is configured on the GE_XP, 10GE_XP, GE_XPE, and 10GE_XPE cards and the same HFL admin VLAN is enabled on the switches.

If two different segments are configured on more than one common switch, the following consequences happen.

- Layer 1 loop
- Flooding of HFL packets across segments if one REP segment fails
- Segment goes down due to LSL time out even if the segment does not have faults

Hence, it is recommended not to configure two different segments on more than one common switch.

- Consider the following configuration:
 - VLAN Load Balancing is configured on GE_XP, 10GE_XP, GE_XPE, and 10GE_XPE cards by specifying the VLB preempt delay.
 - Primary and secondary edge ports are configured on the same switch.
 - HFL or LSL is activated.

This configuration leads to high convergence time during manual preemption, VLB activation, and deactivation (400 to 700 milliseconds).

10.13 ADM-10G Card

The ADM-10G card operates on ONS 15454 SONET, ONS 15454 SDH, ONS 15454 M2, ONS 15454 M6, and DWDM networks to carry optical signals and Gigabit Ethernet signals over DWDM wavelengths for transport. The card aggregates lower bit-rate client SONET or SDH signals (OC-3/STM-1, OC-12/STM-4, OC-48/STM-16, or Gigabit Ethernet) onto a C-band tunable DWDM trunk operating at a higher OC-192/STM-64 rate. In a DWDM network, the ADM-10G card transports traffic over DWDM by mapping Gigabit Ethernet and SONET or SDH circuits onto the same wavelength with multiple protection options.

You can install and provision the ADM-10G card in a linear configuration in:

- Slots 1 to 5 and 12 to 16 in standard and high-density ONS 15454 ANSI shelves (15454-SA-ANSI or 15454-SA-HD), the ETSI ONS 15454 standard shelf assembly, or the ONS 15454 ETSI high-density shelf assembly
- Slot 2 in ONS 15454 M2 chassis
- Slots 2 to 6 in ONS 15454 M6 chassis



Caution

Fan-tray assembly 15454E-CC-FTA (ETSI shelf)/15454-CC-FTA (ANSI shelf) must be installed in a shelf where the ADM-10G card is installed.

The card is compliant with ITU-T G.825 and ITU-T G.783 for SDH signals. It supports concatenated and nonconcatenated AU-4 mapped STM-1, STM-4, and STM-16 signals as specified in ITU-T G.707. The card also complies with Section 5.6 of Telcordia GR-253-CORE and supports synchronous transport signal (STS) mapped OC-3, OC-12, and OC-48 signals as specified in the standard.

The client SFP and trunk XFP are compliant with interface requirements in Telcordia GR-253-CORE, ITU-T G.957 and/or ITU-T G.959.1, and IEEE 802.3.

10.13.1 Key Features

The ADM-10G card has the following high-level features:

- Operates with the TCC2, TCC2P, TCC3, TNC, or TSC.
- Interoperable with TXP_MR_10E, TXP_MR_10E_C, TXP_MR_10EX_C, and OTU2_XP cards.
- Has built-in OC-192/STM-64 add/drop multiplexing function including client, trunk, and STS cross-connect.
- Supports both single-card and double-card (ADM-10G peer group) configuration.
- Supports path protection/SNCP on client and trunk ports for both single-card and double-card configuration. The card does not support path protection/SNCP between a client port and a trunk port. Path protection/SNCP is supported only between two client ports or two trunk ports.
- Supports 1+1 protection on client ports for double-card configuration only.
- Supports SONET, SDH, and Gigabit Ethernet protocols on client SFPs.
- Supports XFP DWDM trunk interface single wavelengths.
- Returns zero bit errors when a TCC2/TCC2P/TCC3/TNC/TSC card switches from active to standby or when manual or forced protection switches occur.
- Has 16 SFP-based client interfaces (gray, colored, coarse wavelength division multiplexing (CWDM), and DWDM optics available).

- Supports STM1, STM4, STM16, and Gigabit Ethernet client signals (8 Gigabit Ethernet maximum).
- Has one XFP-based trunk interface supporting E-FEC/FEC and ITU-T G.709 for double-card configuration.
- Has two XFP-based trunk interface supporting E-FEC/FEC and ITU-T G.709 for single-card configuration.
- Has two SR XFP interlink interfaces supporting redundancy connection with protection board and pass-through traffic for double-card configuration.
- Supports frame-mapped generic framing procedure (GFP-F) and LEX mapping for Ethernet over SONET or SDH.
- Can be installed or pulled from operation, in any slot, without impacting other service cards in the shelf.
- Supports client to client hairpinning, that is, creation of circuits between two client ports for both single-card and double-card configuration. See the [“10.13.11 Circuit Provisioning” section on page 10-105](#) for more detailed information.

10.13.2 ADM-10G POS Encapsulation, Framing, and CRC

The ADM-10G card supports Cisco EoS LEX (LEX) and generic framing procedure framing (GFP-F) encapsulation on 8 POS ports corresponding to 8 GigE ports (Port 1 to Port 8) in both single-card and double-card (ADM-10G peer group) configuration.

You can provision framing on the ADM-10G card as either the default GFP-F or LEX framing. With GFP-F framing, you can configure a 32-bit cyclic redundancy check (CRC) or none (no CRC) (the default). LEX framing supports 16-bit or 32-bit CRC configuration. The framing type cannot be changed when there is a circuit on the port.

On the CTC, navigate to card view and click the Provisioning > Line> Ethernet Tab. To see the various parameters that can be configured on the ethernet ports, see “CTC Display of ethernet Port Provisioning Status”. Parameters such as, admin state, service state, framing type, CRC, MTU and soak time for a port can be configured.

It is possible to create an end-to-end circuit between equipment supporting different kinds of encapsulation (for example, LEX on one side and GFP-F on other side). But, under such circumstances, traffic does not pass through, and an alarm is raised if there is a mismatch.

10.13.2.1 POS Overview

Ethernet data packets need to be framed and encapsulated into a SONET/SDH frame for transport across the SONET/SDH network. This framing and encapsulation process is known as packet over SONET/SDH (POS).

The Ethernet frame comes into the ADM-10G card on a standard Gigabit Ethernet port and is processed through the card’s framing mechanism and encapsulated into a POS frame. When the POS frame exits, the ADM-10G card is in a POS circuit, and this circuit is treated as any other SONET circuit (STS) or SDH circuit (VC) in the ONS node. It is cross-connected and rides the SONET/SDH signal out the port of an optical card and across the SONET/SDH network.

The destination of the POS circuit is a card or a device that supports the POS interface. Data packets in the destination card frames are removed and processed into ethernet frames. The Ethernet frames are then sent to a standard Ethernet port of the card and transmitted onto an Ethernet network.

10.13.2.2 POS Framing Modes

A POS framing mode is the type of framing mechanism employed by the ADM-10G card to frame and encapsulate data packets into a POS signal. These data packets were originally encapsulated in Ethernet frames that entered the standard Gigabit Ethernet interface of the ADM-10G card.

10.13.2.2.1 GFP-F Framing

The GFP-F framing represent standard mapped Ethernet over GFP-F according to ITU-T G.7041. GFP-F defines a standard-based mapping of different types of services onto SONET/SDH. GFP-F maps one variable length data packet onto one GFP packet. GFP-F comprises of common functions and payload specific functions. Common functions are those shared by all payloads. Payload-specific functions are different depending on the payload type. GFP-F is detailed in the ITU recommendation G.7041.

10.13.2.2.2 LEX Framing

LEX encapsulation is a HDLC frame based Cisco Proprietary protocol, where the field is set to values specified in Internet Engineering Task Force (IETF) RFC 1841. HDLC is one of the most popular Layer 2 protocols. The HDLC frame uses the zero insertion/deletion process (commonly known as bit stuffing) to ensure that the bit pattern of the delimiter flag does not occur in the fields between flags. The HDLC frame is synchronous and therefore relies on the physical layer to provide a method of clocking and synchronizing the transmission and reception of frames. The HDLC framing mechanism is detailed in the IETF's RFC 1662, "PPP in HDLC-like Framing."

10.13.2.3 GFP Interoperability

The ADM-10G card defaults to GFP-F encapsulation that is compliant with ITU-T G.7041. This mode allows the card to operate with ONS 15310-CL, ONS 15310-MA, ONS 15310-MA SDH, or ONS 15454 data cards (for example, ONS 15454 CE100T-8 or ML1000-2 cards). GFP encapsulation also allows the ADM-10G card to interoperate with other vendors Gigabit Ethernet interfaces that adhere to the ITU-T G.7041 standard.

10.13.2.4 LEX Interoperability

The LEX encapsulation is compliant with RFC 1841. This mode allows the card to operate with ONS 15310-CL, ONS 15310-MA, ONS 15310-MA SDH, or ONS 15454 data cards (for example, G1000-4/G1K-4 cards, CE-1000-4, ONS 15454 CE100T-8 or ML1000-2 cards).

10.13.3 Faceplate

[Figure 10-31](#) shows the ADM-10G card faceplate.

Figure 10-31 ADM-10G Card Faceplate and Block Diagram

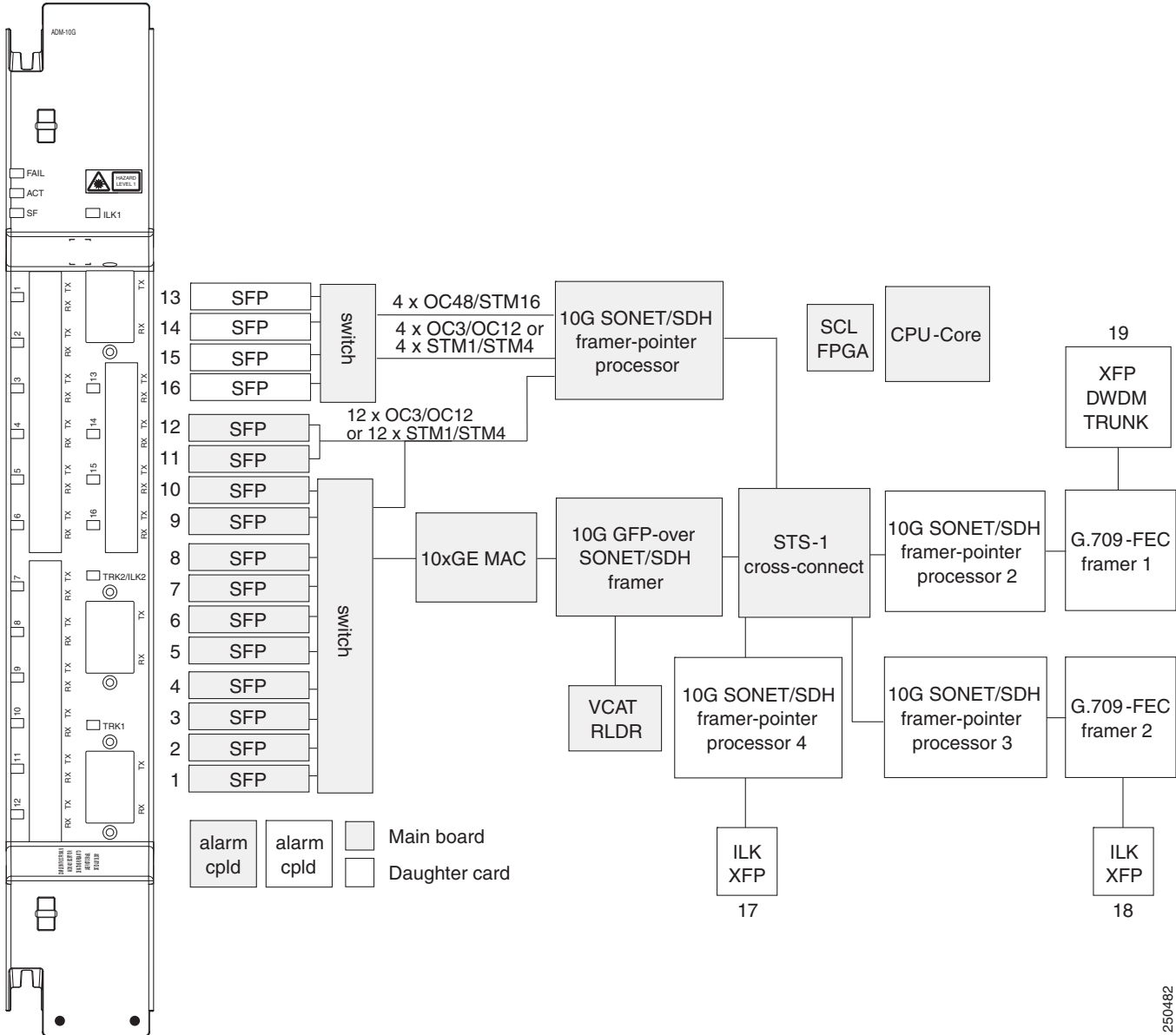

250482

10.13.4 Port Configuration Rules

ADM-10G card client and trunk port capacities are shown in [Figure 10-32](#).

Figure 10-32 ADM-10G Card Port Capacities

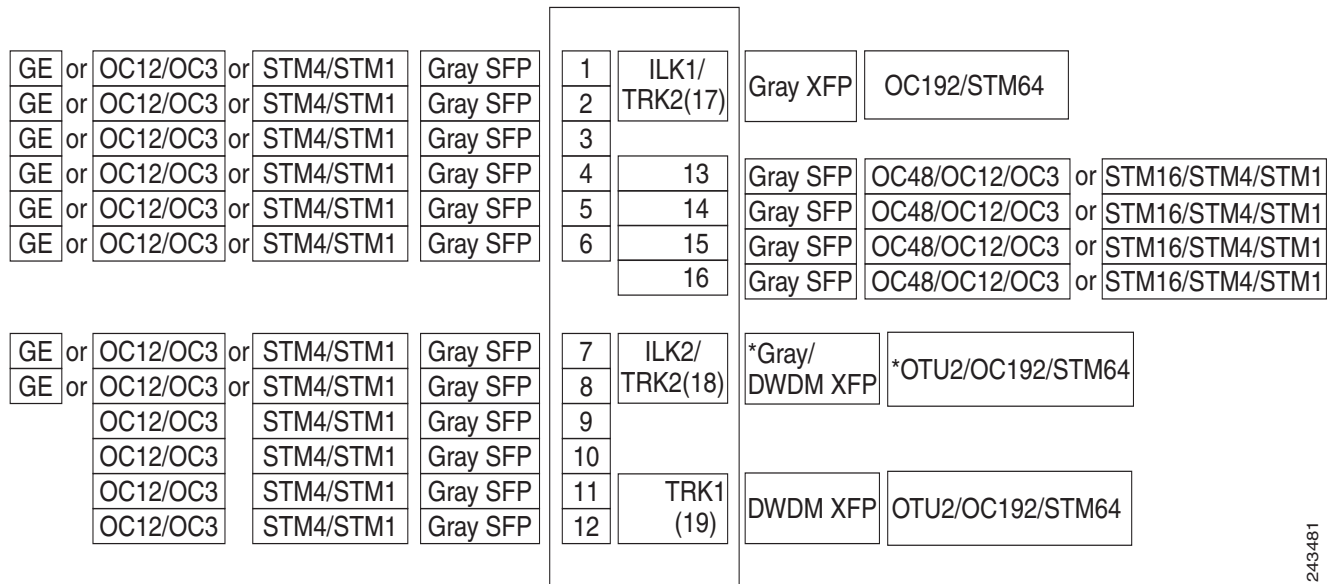

*DWDM XFP and OTU2 is supported only when Port 18 is configured as a trunk interface.

Port 17 acts as trunk2 or ILK1 interface based on single-card or double-card configuration.

10.13.5 Client Interfaces

The ADM-10G card uses LC optical port connectors and, as shown in Figure 10-32, supports up to 16 SFPs that can be utilized for OC-N/STM-N traffic. Eight of the SFPs can be used for Gigabit Ethernet. The interfaces can support any mix of OC-3/STM-1, OC-12/STM-4, OC-48/STM-16, or Gigabit Ethernet of any reach, such as SX, LX, ZX, SR, IR, or LR. The interfaces support a capacity of:

- 4 x OC-48/STM-16
- 16 x OC-12/STM-4
- 16 x OC-3/STM-1
- 8 x GE

The supported client SFPs and XFPs are:

- Gray SFPs
 - 1000Base-SX SFP 850 nm (ONS-SE-G2F-SX=)
 - 1000Base-LX SFP 1310 nm (ONS-SE-G2F-LX=)
 - OC48/STM16 IR1, OC12/STM4 SR1, OC3/STM1 SR1, GE-LX multirate SFP 1310 nm (ONS-SE-Z1=)
 - OC3/STM1 IR1, OC12/STM4 IR1 multirate SFP 1310 nm (ONS-SI-622-I1=)
 - OC48/STM16 SR1 SFP 1310 nm (ONS-SI-2G-S1=)
 - OC48/STM16 IR1 SFP 1310 nm (ONS-SI-2G-I1=)
 - OC48/STM16, 1550 LR2, SM LC (ONS-SE-2G-L2=)

243481

- Colored DWDM SFPs
 - 1000Base-ZX SFP 1550 nm (ONS-SI-GE-ZX=)
 - OC3/STM1 LR2 SFP 1550 nm (ONS-SI-155-L2=)
 - OC48/STM16 LR2 SFP 1550 nm (ONS-SI-2G-L2=)
 - OC48/STM16 SFP (ONS-SC-2G-xx.x)



Note xx.x = 28.7 to 60.6. ONS-SC-2G-28.7, ONS-SC-2G-33.4, ONS-SC-2G-41.3, ONS-SC-2G-49.3, and ONS-SC-2G-57.3 are supported from Release 8.5 and later.

- CWDM SFPs
 - OC48/STM16/GE CWDM SFP (ONS-SC-Z3-xxxx)
- XFPs
 - OC-192/STM-64/10GE XFP 1550 nm (ONS-XC-10G-I2)

10.13.6 Interlink Interfaces

Two 2R interlink interfaces, called ILK1 (Port 17) and ILK2 (Port 18), are provided for creation of ADM-10G peer groups in double-card configurations. In a single-card configuration, Port 17 (OC-192/STM-64) and Port 18 (OC-192/STM-64 or OTU2 payload) must be configured as trunk interfaces. In a double-card configuration (ADM-10G peer group), Ports 17 and 18 must be configured as ILK1 and ILK2 interfaces, respectively. Physically cabling these ports between two ADM-10G cards, located on the same shelf, allows you to configure them as an ADM-10G peer group. The ILK ports carry 10 Gb of traffic each.

The interlink interfaces support STM64 SR1 (ONS-XC-10G-S1=) and 10GE BASE SR (ONS-XC-10G-SR-MM=) XFPs.

10.13.7 DWDM Trunk Interface

The ADM-10G card supports OC-192/STM-64 signal transport and ITU-T G.709 digital wrapping according to the ITU-T G.709 standard. The ADM-10G card supports three trunk XFPs:

- Two DWDM trunks, and one trunk interface in a single-card configuration.
- One DWDM trunk XFP in a double-card configuration.

The supported DWDM trunk XFPs are:

- 10G DWDM (ONS-XC-10G-xx.x=) (colored XFP)
- STM64 SR1 (ONS-XC-10G-S1=) (gray XFP)

10.13.8 Configuration Management

When using OC-48/STM-16 traffic, some contiguous port configurations, listed in [Table 10-43](#), are unavailable due to hardware limitations. This limitation does not impact the Gigabit Ethernet payload.

**Note**

The ADM-10G card cannot be used in the same shelf with SONET or SDH cross-connect cards.

Table 10-43 OC-48/STM-16 Configuration Limitations

OC-48/STM-16 Port Number	Ports Restricted from Optical Traffic
OC-48/STM-16 on Port 13	No OC-N/STM-N on Port 1 through Port 3
OC-48/STM-16 on Port 14	No OC-N/STM-N on Port 4 through Port 6
OC-48/STM-16 on Port 15	No OC-N/STM-N on Port 7 through Port 9
OC-48/STM-16 on Port 16	No OC-N/STM-N on Port 10 through Port 12

**Note**

The total traffic rate for each trunk cannot exceed OC-192/STM-64 on each ADM-10G card, or for each ADM-10G peer group.

**Note**

Gigabit Ethernet is supported on Ports 1 through 8. Ports 9 through Port 12 support only OC-3/STM-1 or OC-12/STM-4.

Additionally, the following guidelines apply to the ADM-10G card:

- Trunk Port 17 supports OC-192/STM-64.
- Trunk Ports 18 and 19 support OC-192/STM-64 and OTU2.
- The interlink port supports OC-192/STM-64.
- Up to six ADM-10G cards can be installed in one shelf.
- Up to 24 ADM-10G cards can be installed per network element (NE) regardless of whether the card is installed in one shelf or in multiple shelves.
- The card can be used in all 15454-SA-ANSI and 15454-SA-HD shelves as well as ETSI ONS 15454 standard and high-density shelves.
- A lamp test function can be activated from CTC to ensure that all LEDs are functional.
- The card can operate as a working protected or working nonprotected card.
- In a redundant configuration, an active card hardware or software failure triggers a switch to the standby card. This switch is detected within 10 ms and is completed within 50 ms.
- ADM-10G cards support jumbo frames with MTU sizes of 64 to 9,216 bytes; the maximum is 9,216.
- After receiving a link or path failure, the ADM-10G card can shut down only the downstream Gigabit Ethernet port.

**Note**

In ADM-10G cards, the Gigabit Ethernet port does not support flow control.

10.13.9 Security

The ADM-10G card that an SFP or XFP is plugged into implements the Cisco Standard Security Code Check Algorithm that keys on the vendor ID and serial number.

If a pluggable port module (PPM) is plugged into a port on the card but fails the security code check because it is not a Cisco PPM, a minor NON-CISCO-PPM alarm is raised.

If a PPM with a nonqualified product ID is plugged into a port on this card—that is, the PPM passes the security code as a Cisco PPM but it has not been qualified for use on the ADM-10G card— a minor UNQUAL-PPM alarm is raised.

10.13.10 Protection

The ADM-10G card supports 1+1 and SONET path protection and SDH SNCP protection architectures in compliance with Telcordia GR-253-CORE, Telcordia GR-1400-CORE, and ITU-T G.841 specifications.

10.13.10.1 Circuit Protection Schemes

The ADM-10G card supports path protection/SNCP circuits at the STS/VC4 (high order) level and can be configured to switch based on signal degrade calculations. The card supports path protection/SNCP on client and trunk ports for both single-card and double-card configuration.



Note

The ADM-10G card supports path protection/SNCP between client ports and trunk port 17. The card does not support path protection/SNCP between client ports and trunk ports 18 or 19. The card does not support path protection/SNCP between port 17 and trunk ports 18 and 19.

The card allows open-ended path protection/SNCP configurations incorporating other vendor equipment. In an open-ended path protection/SNCP, you can specify one source point and two possible endpoints (or two possible source points and one endpoint) and the legs can include other vendor equipment. The source and endpoints are part of the network discovered by CTC.

For detailed information about path protection configurations and SNCPs, refer to the *Cisco ONS 15454 Reference Manual*.

10.13.10.2 Port Protection Schemes

The ADM-10G card supports unidirectional and bidirectional 1+1 APS protection schemes on client ports for double-card configuration (ADM-10G peer group) only. 1+1 APS protection scheme is not supported in single-card configuration. For 1+1 optical client port protection, you can configure the system to use any pair of like facility interfaces that are on different cards of the ADM-10G peer group. For information on optical port protection, refer to the *Cisco ONS 15454 Reference Manual*.

10.13.10.3 Flexible Protection Mechanism

The ADM-10G card can be provisioned as unidirectional path switched ring (UPSR²) or subnetwork connection protection (SNCP) on both Trunk and client side. UPSR or SNCP is supported both in single and double card operation. The ADM-10G card supports up to 288 unprotected high-order (HO) cross connect circuits and up to 192 protected (UPSR or SNCP) per card, resulting in 1728/1152 HO cross

connect circuits per shelf. The HO cross connect circuits provide grooming capabilities for STS level connections, such as STS-1, STS-3c, STS-9c, STS-12c, and STS-24c (CCAT or VCAT) with STS1 level granularity. When installed in a typical central-office bay assembly, a shelf can support up to 5178/3456 HO bidirectional cross connect circuits.

10.13.11 Circuit Provisioning

The ADM-10G card supports STS circuit provisioning both in single-card and double-card (ADM-10G peer group) configuration. The card allows you to create STS circuits between:

- Client and trunk ports
- Two trunk ports
- Two client ports (client-to-client hairpinning)



Note Circuits between two trunk ports are called pass-through circuits.

For an ADM-10G card in single-card configuration, if you are creating STS circuits between two client ports, the following limitation must be considered:

- Gigabit Ethernet to Gigabit Ethernet connections are not supported.

For an ADM-10G card that is part of an ADM-10G peer group, if you are creating STS circuits between two client ports or between client and trunk ports, the following limitations must be considered:

- Gigabit Ethernet to Gigabit Ethernet connections are not supported.
- Optical channel (OC) to OC, OC to Gigabit Ethernet, and Gigabit Ethernet to OC connections between two peer group cards are supported. Peer group connections use interlink port bandwidth, hence, depending on the availability/fragmentation of the interlink port bandwidth, it may not be possible to create an STS circuit from the Gigabit Ethernet/OC client port to the peer card trunk port. This is because, contiguous STSs (that is, STS-3c, STS-12c, STS-24c, and so on) must be available on the interlink port for circuit creation.



Note

There are no limitations to create an STS circuit between two trunk ports.

The two ADM-10G cards used in a paired mode use interlink ports ILK1 (Port 17) and ILK2 (Port 18). A CCAT or VCAT circuit created between the peer ADM-10G cards uses the ILK1 port if the source or destination is Port 19. The circuits created with a single ADM-10G card uses the ILK2 port.

If the circuit is of type STS- nc (where n is an integer and can take values 3,6,9,12,18,24,36,48,96) and uses the ILK2 port, then the starting timeslot needs to use specific timeslots for traffic to flow. The timeslots can be $12m+1$ for STS-12c circuits and $48m+1$ (where m is an integer and can take values 0,1,2,3...) for STS-48c circuits. The timeslots can be $3m+1$ for the other STS- nc circuits.

The following example illustrates how to use the correct timeslot for an ILK2 port:

2. The terms “Unidirectional Path Switched Ring” and “UPSR” may appear in Cisco literature. These terms do not refer to using Cisco ONS 15xxx products in a unidirectional path switched ring configuration. Rather, these terms, as well as “Path Protected Mesh Network” and “PPMN,” refer generally to Cisco’s path protection feature, which may be used in any topological network configuration. Cisco does not recommend using its path protection feature in any particular topological network configuration.

If there is no circuit on the ILK2 port and a STS-3c circuit is created, the circuit uses timeslots 1 to 3. An STS-12c circuit must be created on the ILK2 port later. The STS-12c circuit must have used timeslots 4 to 15. However, the STS-12c circuit uses timeslots starting from 12m+1 (1, 13, 25, and so on) as defined in the above rule. Therefore, before creating the STS-12c circuit, dummy circuits must be created in CTC that consumes STS-9 bandwidth.

10.13.12 ADM-10G CCAT and VCAT Characteristics

The ADM-10G card supports high-order (HO) contiguous concatenation (CCAT) and HO virtual concatenation (VCAT) circuits on 8 GigE ports (Port 1 to Port 8) in both single-card and double-card (ADM-10G peer group) configuration.

To enable end-to-end connectivity in a VCAT circuit that traverses through a third-party network, you can use Open-Ended VCAT circuit creation. For more details, refer to the “Create Circuits and Provisionable Patchcords” chapter in the *Cisco ONS 15454 Procedure Guide*.

The ADM-10G card supports flexible non-LCAS VCAT groups (VCGs). With flexible VCGs, the ADM-10G can perform the following operations:

- Add or remove members from groups
- Put members into or out of service, which also adds/removes them from the group
- Add or remove cross-connect circuits from VCGs

Any operation on the VCG member is service effecting (for instance, adding or removing members from the VCG). Adding or removing cross-connect circuits is not service-affecting, if the associated members are not in the group

The ADM-10G card allows independent routing and protection preferences for each member of a VCAT circuit. You can also control the amount of VCAT circuit capacity that is fully protected, unprotected, or uses Protection Channel Access (PCA) (when PCA is available). Alarms are supported on a per-member as well as per virtual concatenation group (VCG) basis.

The ADM-10G card supports both automatic and manual routing for VCAT circuit, that is, all members are manually or automatically routed. Bidirectional VCAT circuits are symmetric, which means that the same number of members travel in each direction. With automatic routing, you can specify the constraints for individual members; with manual routing, you can select different spans for different members. Two types of automatic and manual routing are available for VCAT members: common fiber routing and split routing.

The ADM-10G card supports VCAT common fiber routing and VCAT split fiber (diverse) routing. With VCAT split fiber routing, each member can be routed independently through the SONET or SDH or DWDM network instead of having to follow the same path as required by CCAT and VCAT common fiber routing. This allows a more efficient use of network bandwidth, but the different path lengths and different delays encountered may cause slightly different arrival times for the individual members of the VCG. The VCAT differential delay is this relative arrival time measurement between members of a VCG. The maximum tolerable VCAT split fiber routing differential delay for the ADM-10G card is approximately 55 milliseconds. A loss of alignment alarm is generated if the maximum differential delay supported is exceeded.

The differential delay compensation function is automatically enabled when you choose split fiber routing during the CTC circuit configuration process. CCAT and VCAT common fiber routing do not enable or need differential delay support.

**Caution**

Protection switches with switching time of less than 60 milliseconds are not guaranteed with the differential delay compensation function enabled. The compensation time is added to the switching time.

**Note**

For TL1, EXPBUFFERS parameter must be set to ON in the ENT-VCG command to enable support for split fiber routing.

Available Circuit Sizes

Table 10-44 and Table 10-45 show the circuit sizes available for the ADM-10G card.

Table 10-44 Supported SONET Circuit Sizes of ADM-10G card on ONS 15454

CCAT	VCAT High Order
STS-1	STS-1-1nV ($n= 1$ to 21)
STS-3c	STS-3c-mv ($m= 1$ to 7)
STS-6c	
STS-9c	
STS-12c	
STS-24c	

Table 10-45 Supported SDH Circuit Sizes of ADM-10G card on ONS 15454 SDH

CCAT	VCAT High Order
VC-4	VC-4-mv ($m= 1$ to 7)
VC-4-2c	
VC-4-3c	
VC-4-4c	
VC-4-8c	

**Note**

In ADM-10G cards, the Gigabit Ethernet port does not support flow control. When less than seven VC-4s are configured for the port, with the client traffic expected to be below the line rate, a burst in traffic beyond the supposed bandwidth leads to packet loss. It is, therefore, recommended to use an external flow control mechanism with less than seven VC-4s configured. Connecting a GE-XP or GE-XPE card between the client traffic and the ADM-10G Gigabit Ethernet interface enables such flow control.

10.13.13 Automatic Laser Shutdown

The ALS procedure is supported on both client and trunk interfaces. On the client interface, ALS is compliant with ITU-T G.664 (6/99). On the data application and trunk interface, the switch on and off pulse duration is greater than 60 seconds. The on and off pulse duration is user-configurable. For details on ALS provisioning for the card, refer to the *Cisco ONS 15454 DWDM Procedure Guide*.

Intermediate Path Performance Monitoring

Intermediate path performance monitoring (IPPM) allows a node to monitor the constituent channel of an incoming transmission signal. You can enable IPPM for STS/VC-4s payload on OCn and Trunk ports of ADM-10G card. The IPPM is compliant with GR253/G.826.

Software Release 9.2 and higher enables the ADM-10G card to monitor the near-end and far-end PM data on individual STS/VC-4 payloads by enabling IPPM. After provisioning IPPM on the card, service providers can monitor large amounts of STS/VC-4 traffic through intermediate nodes, thus making troubleshooting and maintenance activities more efficient. IPPM occurs only on STS/VC-4 paths that have IPPM enabled, and TCAs are raised only for PM parameters on the selected IPPM paths.

For a CCAT circuit, you can enable IPPM only on the first STS/VC-4 of the concatenation group. For a VCAT circuit, you can enable IPPM independently on each member STS/VC-4 of the concatenation group.

Pointer Justification Count Performance Monitoring

Pointers are used to compensate for frequency and phase variations. Pointer justification counts indicate timing errors on SONET networks. When a network is out of synchronization, jitter and wander occur on the transported signal. Excessive wander can cause terminating equipment to slip.

Slips cause different effects in service. Voice service has intermittent audible clicks. Compressed voice technology has short transmission errors or dropped calls. Fax machines lose scanned lines or experience dropped calls. Digital video transmission has distorted pictures or frozen frames. Encryption service loses the encryption key, causing data to be transmitted again.

Pointers provide a way to align the phase variations in STS and VC4 payloads. The STS payload pointer is located in the H1 and H2 bytes of the line overhead. Clocking differences are measured by the offset in bytes from the pointer to the first byte of the STS synchronous payload envelope (SPE) called the J1 byte. Clocking differences that exceed the normal range of 0 to 782 can cause data loss.

There are positive (PPJC) and negative (NPJC) pointer justification count parameters. PPJC is a count of path-detected (PPJC-PDET-P) or path-generated (PPJC-PGEN-P) positive pointer justifications. NPJC is a count of path-detected (NPJC-PDET-P) or path-generated (NPJC-PGEN-P) negative pointer justifications depending on the specific PM name. PJCDIFF is the absolute value of the difference between the total number of detected pointer justification counts and the total number of generated pointer justification counts. PJCS-PDET-P is a count of the one-second intervals containing one or more PPJC-PDET or NPJC-PDET. PJCS-PGEN-P is a count of the one-second intervals containing one or more PPJC-PGEN or NPJC-PGEN.

A consistent pointer justification count indicates clock synchronization problems between nodes. A difference between the counts means that the node transmitting the original pointer justification has timing variations with the node detecting and transmitting this count. Positive pointer adjustments occur when the frame rate of the SPE is too slow in relation to the rate of the STS-1.

You must enable PPJC and NPJC performance monitoring parameters for ADM-10Gcard. In CTC, the count fields for PPJC and NPJC PMs appear white and blank unless they are enabled on the card view Provisioning tab.

Performance Monitoring Parameter Definitions

This section describes the STS and VC-4 path performance monitoring parameters that ADM-10G card support.

Table 10-46 lists the STS near-end path performance monitoring parameters.

Table 10-46 STS Near-end Path Performance Monitoring Parameters

Parameter	Definition
CV-P	Near-End STS Path Coding Violations (CV-P) is a count of BIP errors detected at the STS path layer (that is, using the B3 byte). Up to eight BIP errors can be detected per frame; each error increments the current CV-P second register.
ES-P	Near-End STS Path Errored Seconds (ES-P) is a count of the seconds when at least one STS path BIP error was detected. An AIS Path (AIS-P) defect (or a lower-layer, traffic-related, near-end defect) or a Loss of Pointer Path (LOP-P) defect can also cause an ES-P.
SES-P	Near-End STS Path Severely Errored Seconds (SES-P) is a count of the seconds when K (2400) or more STS path BIP errors were detected. An AIS-P defect (or a lower-layer, traffic-related, near-end defect) or an LOP-P defect can also cause an SES-P.
UAS-P	Near-End STS Path Unavailable Seconds (UAS-P) is a count of the seconds when the STS path was unavailable. An STS path becomes unavailable when ten consecutive seconds occur that qualify as SES-Ps, and continues to be unavailable until ten consecutive seconds occur that do not qualify as SES-Ps.
FC-P	Near-End STS Path Failure Counts (FC-P) is a count of the number of near-end STS path failure events. A failure event begins when an AIS-P failure, an LOP-P failure, a UNEQ-P failure, or a Section Trace Identifier Mismatch Path (TIM-P) failure is declared. A failure event also begins if the STS PTE that is monitoring the path supports Three-Bit (Enhanced) Remote Failure Indication Path Connectivity (ERFI-P-CONN) for that path. The failure event ends when these failures are cleared.
PPJC-PDET-P	Positive Pointer Justification Count, STS Path Detected (PPJC-PDET-P) is a count of the positive pointer justifications detected on a particular path in an incoming SONET signal.
PPJC-PGEN-P	Positive Pointer Justification Count, STS Path Generated (PPJC-PGEN-P) is a count of the positive pointer justifications generated for a particular path to reconcile the frequency of the SPE with the local clock.
NPJC-PDET-P	Negative Pointer Justification Count, STS Path Detected (NPJC-PDET-P) is a count of the negative pointer justifications detected on a particular path in an incoming SONET signal.

Table 10-46 STS Near-end Path Performance Monitoring Parameters

Parameter	Definition
NPJC-PGEN-P	Negative Pointer Justification Count, STS Path Generated (NPJC-PGEN-P) is a count of the negative pointer justifications generated for a particular path to reconcile the frequency of the SPE with the local clock.
PJCDIFF-P	Pointer Justification Count Difference, STS Path (PJCDIFF-P) is the absolute value of the difference between the total number of detected pointer justification counts and the total number of generated pointer justification counts. That is, PJCDiff-P is equal to (PPJC-PGEN-P - NPJC-PGEN-P) - (PPJC-PDET-P - NPJC-PDET-P).
PJCS-PDET-P	Pointer Justification Count Seconds, STS Path Detect (NPJCS-PDET-P) is a count of the one-second intervals containing one or more PPJC-PDET or NPJC-PDET.
PJCS-PGEN-P	Pointer Justification Count Seconds, STS Path Generate (PJCS-PGEN-P) is a count of the one-second intervals containing one or more PPJC-PGEN or NPJC-PGEN.

Table 10-47 gives the VC-4 near-end path performance monitoring parameters definition that ADM-10G card support.

Table 10-47 VC-4 Near-end Path Performance Monitoring Parameters

Parameter	Definition
HP-EB	High-Order Path Errored Block (HP-EB) indicates that one or more bits are in error within a block.
HP-BBE	High-Order Path Background Block Error (HP-BBE) is an errored block not occurring as part of an SES.
HP-ES	High-Order Path Errored Second (HP-ES) is a one-second period with one or more errored blocks or at least one defect.
HP-SES	High-Order Path Severely Errored Seconds (HP-SES) is a one-second period containing 30 percent or more errored blocks or at least one defect. SES is a subset of ES.
HP-UAS	High-Order Path Unavailable Seconds (HP-UAS) is a count of the seconds when the VC path was unavailable. A high-order path becomes unavailable when ten consecutive seconds occur that qualify as HP-SESs, and it continues to be unavailable until ten consecutive seconds occur that do not qualify as HP-SESs.
HP-BBER	High-Order Path Background Block Error Ratio (HP-BBER) is the ratio of BBE to total blocks in available time during a fixed measurement interval. The count of total blocks excludes all blocks during SESs.
HP-ESR	High-Order Path Errored Second Ratio (HP-ESR) is the ratio of errored seconds to total seconds in available time during a fixed measurement interval.
HP-SESR	High-Order Path Severely Errored Second Ratio (HP-SESR) is the ratio of SES to total seconds in available time during a fixed measurement interval.

Table 10-47 VC-4 Near-end Path Performance Monitoring Parameters

Parameter	Definition
HP-PPJC-PDET	High-Order, Positive Pointer Justification Count, Path Detected (HP-PPJC-Pdet) is a count of the positive pointer justifications detected on a particular path on an incoming SDH signal.
HP-NPJC-PDET	High-Order, Negative Pointer Justification Count, Path Detected (HP-NPJC-Pdet) is a count of the negative pointer justifications detected on a particular path on an incoming SDH signal.
HP-PPJC-PGEN	High-Order, Positive Pointer Justification Count, Path Generated (HP-PPJC-Pgen) is a count of the positive pointer justifications generated for a particular path.
HP-NPJC-PGEN	High-Order, Negative Pointer Justification Count, Path Generated (HP-NPJC-Pgen) is a count of the negative pointer justifications generated for a particular path.
HP-PJCDIFF	High-Order Path Pointer Justification Count Difference (HP-PJCDiff) is the absolute value of the difference between the total number of detected pointer justification counts and the total number of generated pointer justification counts. That is, HP-PJCDiff is equal to (HP-PPJC-PGen - HP-NPJC-PGen) - (HP-PPJC-PDet - HP-NPJC-PDet).
HP-PJCS-PDET	High-Order Path Pointer Justification Count Seconds (HP-PJCS-PDet) is a count of the one-second intervals containing one or more HP-PPJC-PDet or HP-NPJC-PDet.
HP-PJCS-PGEN	High-Order Path Pointer Justification Count Seconds (HP-PJCS-PGen) is a count of the one-second intervals containing one or more HP-PPJC-PGen or HP-NPJC-PGen.

10.13.14 ADM-10G Card-Level Indicators

Table 10-48 describes the card-level LEDs on the ADM-10G card.

Table 10-48 ADM-10G Card-Level Indicators

Card-Level LED	Description
ACT LED Green (Active) Amber (Standby)	Green indicates that the card is operational (one or both ports active) and ready to carry traffic. Amber indicates that the card is operational and in standby (protect) mode.
Red FAIL LED	The red FAIL LED indicates that the card's processor is not ready. This LED is on during reset. The FAIL LED flashes during the boot process. If the card is inserted in a slot that is preprovisioned for a different card, this LED flashes until a Missing Equipment Attribute (MEA) condition is raised. You might also need to replace the card if the red FAIL LED persists.
Amber SF LED	The amber SF LED indicates a signal failure or condition such as LOS, LOF, or high BER errors on one or more of the card's ports. The amber SF LED is also on if the transmit and receive fibers are incorrectly connected. If the fibers are properly connected and the link is working, the light turns off.

10.13.15 ADM-10G Card Port-Level Indicators

Table 10-49 describes the port-level LEDs on the ADM-10G card.



Note

Client or trunk ports can each be in active or standby mode as defined in the related section for each specific protection type. For example, fiber-switched protection has active or standby trunk ports; 1+1 APS protection has active or standby client ports, and client 1+1 protection does not utilize active or standby ports.

Table 10-49 ADM-10G Card Port-Level LED Indications

Port-Level Status	Tri-color LED Description
The port-level LED is active and unprotected.	<ul style="list-style-type: none"> If a port is in OOS/locked state for any reason, the LED is turned off. If a port is in IS/unlocked state and the PPM is preprovisioned or is physically equipped with no alarms, the LED is green. If a port is in IS state and the PPM is physically equipped but does have alarms, the LED is red.
The port-level LED is in standby.	<ul style="list-style-type: none"> If a port is in OOS/locked state for any reason, the LED is turned off. If a port is in the IS/unlocked state and the PPM is preprovisioned or is physically equipped with no alarms, the LED is amber. If a port is in IS state and physically equipped but does have alarms, the LED is red.

10.14 OTU2_XP Card

The OTU2_XP card is a single-slot card with four ports with XFP-based multirate (OC-192/STM-64, 10GE, 10G FC, IB_5G) Xponder for the ONS 15454 ANSI and ETSI platforms. The OTU2_XP card supports multiple configurations.

Table 10-50 describes the different configurations supported by the OTU2_XP card and the ports that must be used for these configurations.

Table 10-50 OTU2_XP Card Configurations and Ports

Configuration	Port 1	Port 2	Port 3	Port 4
2 x 10G transponder	Client port 1	Client port 2	Trunk port 1	Trunk port 2
2 x 10G standard regenerator (with enhanced FEC (E-FEC) only on one port)	Trunk port 1	Trunk port 2	Trunk port 1	Trunk port 2
10 GE LAN Phy to WAN Phy	Client port	Client port in transponder or trunk port in regenerator configuration	Trunk port	Trunk port in transponder or regenerator configuration

Table 10-50 OTU2_XP Card Configurations and Ports (continued)

Configuration	Port 1	Port 2	Port 3	Port 4
1 x 10G E-FEC regenerator (with E-FEC on two ports)	Not used	Not used	Trunk port	Trunk port
1 x 10G splitter protected transponder	Client port	Not used	Trunk port (working)	Trunk port (protect)

All the four ports are ITU-T G.709 compliant and support 40 channels (wavelengths) at 100-GHz channel spacing in the C-band (that is, the 1530.33 nm to 1561.42 nm wavelength range).

The OTU2_XP card can be installed in Slots 1 through 6 or 12 through 17. The OTU2_XP card supports SONET SR1, IR2, and LR2 XFPs, 10GE BASE SR, SW, LR, LW, ER, EW, and ZR XFPs, and 10G FC MX-SN-I and SM-LL-L XFPs.

**Caution**

Fan-tray assembly 15454E-CC-FTA (ETSI shelf)/15454-CC-FTA (ANSI shelf) must be installed in a shelf where the OTU2_XP card is installed.

10.14.1 Key Features

The OTU2_XP card has the following high-level features:

- 10G transponder, regenerator, and splitter protection capability on the ONS 15454 DWDM platform.
- Compatible with the ONS 15454 ANSI high-density shelf assembly, the ETSI ONS 15454 shelf assembly, and the ETSI ONS 15454 high-density shelf assembly. Compatible with TCC2/TCC2P/TCC3/TNC/TSC cards.
- Interoperable with TXP_MR_10E and TXP_MR_10E_C cards.
- Four port, multirate (OC-192/STM-64, 10G Ethernet WAN Phy, 10G Ethernet LAN Phy, 10G Fibre Channel, IB_5G) client interface. The client signals are mapped into an ITU-T G.709 OTU2 signal using standard ITU-T G.709 multiplexing.
- ITU-T G.709 framing with standard Reed-Soloman (RS) (255,237) FEC. Performance monitoring and ITU-T G.709 Optical Data Unit (ODU) synchronous mapping. Enhanced FEC (E-FEC) with ITU-T G.709 ODU with greater than 8 dB coding gain.
- The trunk rate remains the same irrespective of the FEC configuration. The error coding performance can be provisioned as follows::
 - FEC—Standard ITU-T G.709.
 - E-FEC—Standard ITU-T G.975.1 I.7.
- IEEE 802.3 frame format supported for 10 Gigabit Ethernet interfaces. The minimum frame size is 64 bytes. The maximum frame size is user-provisionable.
- Supports fixed/no fixed stuff mapping (insertion of stuffing bytes) for 10G Ethernet LAN Phy signals (only in transponder configuration).
- Supports 10G Ethernet LAN Phy to 10G Ethernet WAN Phy conversion on Ports 1 (client port) and 3 (trunk port).

- Supports 10G Ethernet LAN Phy to WAN Phy conversion using CTC and TL1. When enabled on the OTU2_XP card, the first Channel (Ports 1 and 3) supports LAN to WAN conversion. The second channel carries normal 10GE, 10G FC, and OC192/STM64 traffic.
- The LAN Phy to WAN Phy conversion functions in accordance to WAN Interface Sublayer (WIS) mechanism as defined by IEEE802.3ae (IEEE Std 802.3ae-2002, Amendment to CSMA/CD).
- Default configuration is transponder, with trunk ports configured as ITU-T G.709 standard FEC.
- In transponder or regenerator configuration, if one of the ports is configured the corresponding port is automatically created.
- In regenerator configuration, only Ports 3 and 4 can be configured as E-FEC. Ports 1 and 2 can be configured only with standard FEC.
- When port pair 1-3 or 2-4 is configured as regenerator (that is, card mode is standard regenerator), the default configuration on Ports 3 and 4 is automatically set to standard FEC.
- When Ports 3 and 4 are configured as regenerator (that is, card mode is E-FEC regenerator), the default configuration on both these ports is automatically set to E-FEC.
- In splitter protected transponder configuration, the trunk ports (Ports 3 and 4) are configured as ITU-T G.709 standard FEC or E-FEC.
- Supports protection through Y-cable protection scheme.



Note When enabled, the 10G Ethernet LAN Phy to WAN Phy conversion feature does not support Y-cable protection on the LAN to WAN interface (ports 1 and 3).

- Client ports support SONET SR1, IR2, and LR2 XFPs, 10GE BASE SR, SW, LR, LW, ER, EW, and ZR XFPs, and 10G FC MX-SN-I and SM-LL-L XFPs.
- Following are the OTU2 link rates that are supported on the OTU2_XP trunk port:
 - Standard G.709 (10.70923 Gbps) when the client is provisioned as “SONET” (including 10G Ethernet WAN PHY) (9.95328 Gbps).
 - G.709 overclocked to transport 10GE as defined by ITU-T G. Sup43 Clause 7.2 (11.0491 Gbps) when the client is provisioned as “10G Ethernet LAN Phy” (10.3125 Gbps) with “No Fixed Stuff” enabled.
 - G.709 overclocked to transport 10GE as defined by ITU-T G. Sup43 Clause 7.1 (11.0957 Gbps) when the client is provisioned as “10G Ethernet LAN Phy” (10.3125 Gbps) with “No Fixed Stuff” disabled.
 - G.709 proprietary overclocking mode to transport 10G FC (11.3168 Gbps) when the client is provisioned as “10G Fiber Channel” (10.518 Gbps).
 - Proprietary rate at the trunk when the client is provisioned as IB_5G.
- The MTU setting is used to display the ifInErrors and OverSizePkts counters on the receiving trunk and client port interfaces. Traffic of frame sizes up to 65535 bytes pass without any packet drops, from the client port to the trunk port and vice versa irrespective of the MTU setting.

10.14.2 Faceplate and Block Diagram

Figure 10-33 shows the OTU2_XP card faceplate and block diagram.

Figure 10-33 OTU2_XP Card Faceplate and Block Diagram

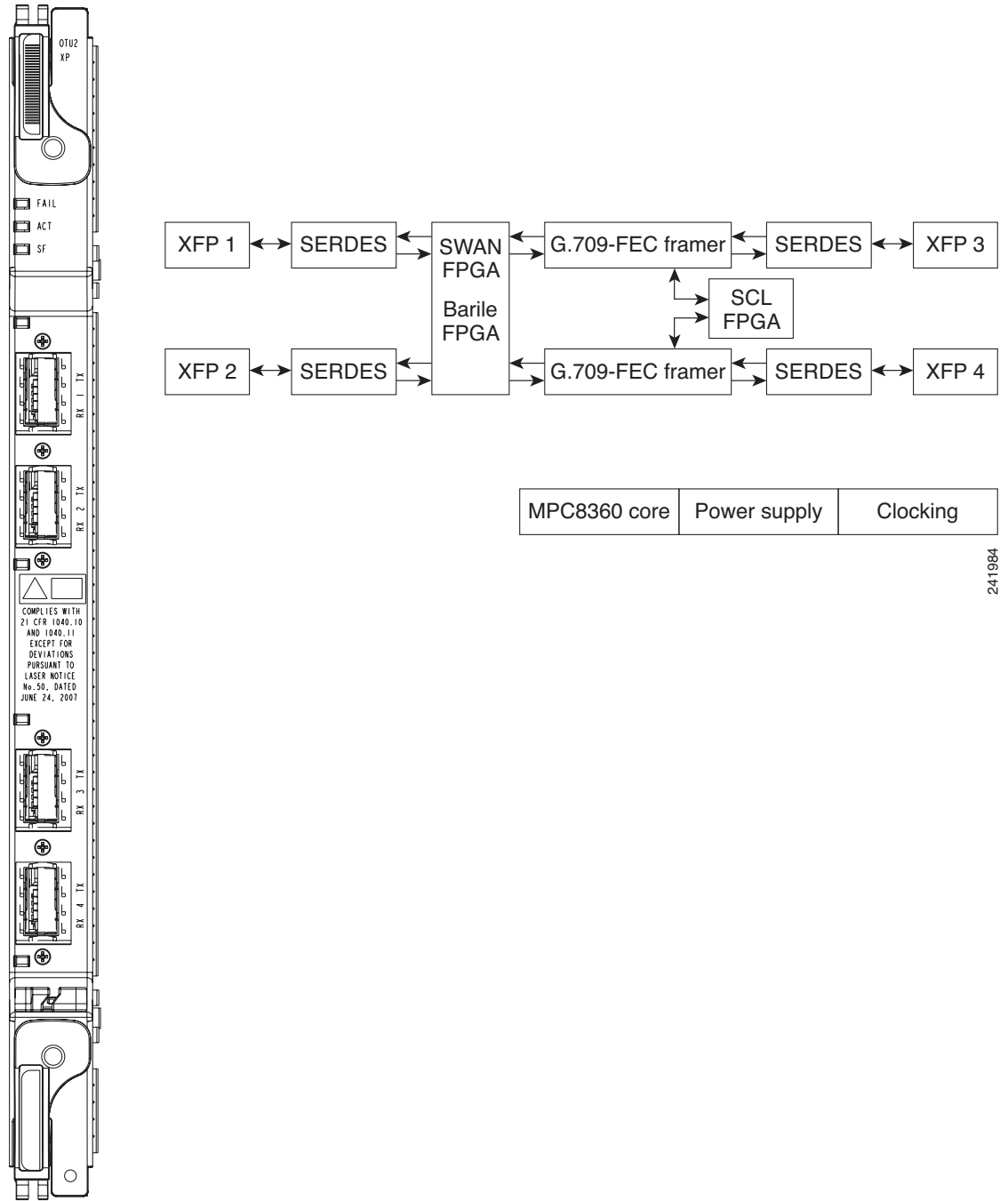

241984



Note

The Swan FPGA is automatically loaded when the LAN Phy to WAN Phy conversion feature is enabled on the OTU2_XP card. The Barile FPGA is automatically loaded when the LAN Phy to WAN Phy conversion feature is disabled on the OTU2_XP card.

10.14.3 OTU2_XP Card-Level Indicators

Table 10-51 describes the card-level LEDs on the OTU2_XP card.

Table 10-51 OTU2_XP Card-Level Indicators

Card-Level LED	Description
Red FAIL LED	The red FAIL LED indicates that the card processor is not ready. This LED is on during reset. The FAIL LED flashes during the boot process. If the card is inserted in a slot that is preprovisioned for a different card, this LED flashes until a Missing Equipment Attribute (MEA) condition is raised. You might also need to replace the card if the red FAIL LED persists.
ACT LED Green (Active)	If the ACT LED is green, the card is operational (one or more ports active) and ready to carry traffic.
Amber SF LED	The amber SF LED indicates a signal failure or condition such as LOS, LOF, or high BER errors on one or more of the card ports. The amber SF LED is also on if the transmit and receive fibers are incorrectly connected. If the fibers are properly connected and the link is working, the light turns off.

10.14.4 OTU2_XP Port-Level Indicators

Table 10-52 describes the PPM port-level LEDs on the OTU2_XP card for both client and trunk ports.



Note

Client or trunk ports can each be in active or standby mode as defined in the related section for each specific protection type. For example, fiber-switched protection has active or standby trunk ports; 1+1 APS protection has active or standby client ports, and client 1+1 protection does not utilize active or standby ports.

Table 10-52 OTU2_XP PPM Port-Level Indicators

Port-Level Status	Tri-color LED Description
The port-level LED is active and unprotected.	<ul style="list-style-type: none"> If a port is in OOS/locked state for any reason, the LED is turned off. If a port is in IS/unlocked state and the PPM is preprovisioned or is physically equipped with no alarms, the LED is green. If a port is in IS state and the PPM is physically equipped but does have alarms, the LED is red.
The port-level LED is in standby.	<ul style="list-style-type: none"> If a port is in OOS/locked state for any reason, the LED is turned off. If a port is in the IS/unlocked state and the PPM is preprovisioned or is physically equipped with no alarms, the LED is amber. If a port is in IS state and physically equipped but does have alarms, the LED is red.

10.14.5 OTU2_XP Card Interface

The OTU2_XP card is a multi-functional card that operates in different configurations, such as transponder, standard regenerator, E-FEC regenerator, and 10G Ethernet LAN Phy to WAN Phy conversion mode. The OTU2_XP card acts as a protected transponder, when the 10G Ethernet LAN Phy to WAN Phy is in splitter protected transponder configuration mode.

Depending on the configuration of the OTU2_XP card, the ports act as client or trunk ports (see [Table 10-50](#)). This following section describes the client and trunk rates supported on the OTU2_XP card for different card configurations:

10.14.5.1 Client Interface

In transponder and 10G Ethernet LAN Phy to WAN Phy card configurations, Ports 1 and 2 act as client ports and in splitter protected transponder configuration, Port 1 acts as a client port. For these card configurations, the client rates supported are:

- OC-192/STM-64
- 10G Ethernet WAN Phy
- 10G Ethernet LAN Phy
- 10G Fibre Channel
- IB_5G

10.14.5.2 Trunk Interface

In transponder, 10G Ethernet LAN Phy to WAN Phy, and splitter protected transponder card configurations, Ports 3 and 4 act as trunk ports. For these card configurations, the trunk rates supported are:

- OC-192/STM-64
- 10G Ethernet WAN Phy
- 10G Ethernet LAN Phy
- 10G Fibre Channel
- OTU2 with ITU-T G.709 for OC-192 client interface
- OTU2e with ITU-T G.709 for 10G Ethernet LAN Phy client interface
- Proprietary rate at the trunk when the client is provisioned as IB_5G.

In standard regenerator card configuration, all four ports act as trunk ports and in E-FEC regenerator configuration, Ports 3 and 4 act as the trunk ports. For these card configurations, the trunk rate supported is OTU2 G.709

**Note**

The above mentioned OTU2 signal must be an OC-192/STM-64, 10G Ethernet WAN Phy, 10G Ethernet LAN Phy, or 10G Fibre Channel signal packaged into an OTU2 G.709 frame. Additionally, the standard regenerator and E-FEC regenerator configuration supports an OTU2 signal that is OTU2 has been generated by multiplexing four ODU1 signals.

10.14.6 Configuration Management

The OTU2_XP card supports the following configuration management parameters:

- **Card Configuration**—Provisionable card configuration: Transponder, Standard Regen, Enhanced FEC, or Mixed, or 10G Ethernet LAN Phy to WAN Phy.
- **Port Mode**—Provisionable port mode when the card configuration is set as Mixed. The port mode can be chosen as either Transponder or Standard Regen for each port pair (1-3 and 2-4). For card configurations other than Mixed, CTC automatically sets the port mode depending on the selected card configuration. For 10G Ethernet LAN Phy to WAN Phy mode, CTC automatically selects the port pair (1-3) as 10G Ethernet LAN Phy to WAN Phy. Port pair (2-4) in 10G Ethernet LAN Phy to WAN Phy mode is selected as Transponder or Standard Regen.
- **Termination Mode**—Provisionable termination mode when the card configuration is set as either Transponder or Mixed. The termination mode can be chosen as Transparent, Section, or Line. For Standard Regen and Enhanced FEC card configurations, CTC automatically sets the termination mode as Transparent. For 10G Ethernet LAN Phy to WAN Phy mode, CTC automatically selects the Termination Mode of port pair (1-3) as Line. You cannot provision the Termination Mode parameter.
- **AIS/Squelch**—Provisionable AIS/Squelch mode configuration when the card configuration is set as either Transponder or Mixed. The termination mode configuration can be chosen as AIS or Squelch. For Standard Regen and Enhanced FEC card configurations, CTC automatically sets the termination mode configuration as AIS. For 10G Ethernet LAN Phy to WAN Phy mode, the CTC automatically selects the AIS/Squelch of port pair (1-3) as Squelch. You cannot provision the AIS/Squelch parameter.



Note

When you choose the 10G Ethernet LAN Phy to WAN Phy conversion, the Termination mode is automatically set to LINE. The AIS/Squelch is set to SQUELCH and ODU Transparency is set to Cisco Extended Use for Ports 1 and 3.

- **Regen Line Name**—User-assigned text string for regeneration line name.
- **ODU Transparency**—Provisionable ODU overhead byte configuration, either Transparent Standard Use or Cisco Extended Use. See the [“10.14.10 ODU Transparency” section on page 10-121](#) for more detailed information. For 10G Ethernet LAN Phy to WAN Phy mode, CTC automatically selects the ODU Transparency as Cisco Extended Use. You cannot provision the ODU Transparency parameter.
- **Port name**—User-assigned text string.
- **Admin State/Service State**—Administrative and service states to manage and view port status.
- **ALS Mode**—Provisionable ALS function.
- **Reach**—Provisionable optical reach distance of the port.
- **Wavelength**—Provisionable wavelength of the port.
- **AINS Soak**—Provisionable automatic in-service soak period.

10.14.7 OTU2_XP Card Configuration Rules

The following rules apply to OTU2_XP card configurations:

- When you preprovision the card, port pairs 1-3 and 2-4 come up in the default Transponder configuration.

- The port pairs 1-3 and 2-4 can be configured in different modes only when the card configuration is Mixed. If the card configuration is Mixed, you must choose different modes on port pairs 1-3 and 2-4 (that is, one port pair in Transponder mode and the other port pair in Standard Regen mode).
- If the card is in Transponder configuration, you can change the configuration to Standard Regen or Enhanced FEC.
- If the card is in Standard Regen configuration and you have configured only one port pair, then configuring payload rates for the other port pair automatically changes the card configuration to Mixed, with the new port pair in Transponder mode.
- If the card is in Standard Regen configuration, you cannot directly change the configuration to Enhanced FEC. You have to change to Transponder configuration and then configure the card as Enhanced FEC.
- If the card is in Enhanced FEC configuration, Ports 1 and 2 are disabled. Hence, you cannot directly change the configuration to Standard Regen or Mixed. You must remove the Enhanced FEC group by moving the card to Transponder configuration, provision PPM on Ports 1 and 2, and then change the card configuration to Standard Regen or Mixed.
- If the card is in Standard Regen or Enhanced FEC configuration, you cannot change the payload rate of the port pairs. You have to change the configuration to Transponder, change the payload rate, and then move the card configuration back to Standard Regen or Enhanced FEC.
- If any of the affected ports are in IS (ANSI) or Unlocked-enabled (ETSI) state, you cannot change the card configuration.
- If IB_5G payload has to be provisioned, the NE Default should match the values listed in the [Table 10-53](#). For more information on editing the NE Default values, see the “[NTP-G135 Edit Network Element Defaults](#)” task.

Table 10-53 OTU2_XP Card Configuration for IB_5G Payload Provisioning

Parameter	NE Default Name	Value
FEC	OTU2-XP.otn.otnLines.FEC	Standard
ITU-T G.709 OTN	OTU2-XP.otn.otnLines.G709OTN	Enable
Termination Mode	OTU2-XP.config.port.TerminationMode	Transparent
ODU Transparency	OTU2-XP.config.port.OduTransparency	Cisco Extended Use
AIS/Squelch	OTU2-XP.config.port.AisSquelchMode	Squelch

- If the card is changed to 10G Ethernet LAN Phy to WAN Phy, the first PPM port is deleted and replaced by a 10G Ethernet port; the third PPM port is deleted and automatically replaced with OC192/STM64 (SONET/SDH) port. The third PPM port is automatically deleted and the third PPM port is replaced with OC192/STM64 (SONET/SDH).

[Table 10-54](#) provides a summary of transitions allowed for the OTU2_XP card configurations.

Table 10-54 Card Configuration Transition Summary

Card Configuration	Transition To				
	Transponder	Standard Regen	Enhanced FEC	Mixed	10G Ethernet LAN Phy to WAN Phy
Transponder	—	Yes	Yes	Yes	Yes
Standard Regen	Yes	—	No	Yes	Yes

Table 10-54 Card Configuration Transition Summary (continued)

Card Configuration	Transition To				
	Transponder	Standard Regen	Enhanced FEC	Mixed	10G Ethernet LAN Phy to WAN Phy
Enhanced FEC	Yes	No	—	No	No
Mixed	Yes	Yes	No	—	Yes
10G Ethernet LAN Phy to WAN Phy	Yes	Yes	No	The 10G Ethernet LAN Phy to WAN Phy to Mixed is supported if the Port pair 1-3 is chosen as Transponder. The 10G Ethernet LAN Phy to WAN Phy to Mixed is not supported if the Port pair 1-3 is chosen as Standard Regen.	—

10.14.8 Security

The OTU2_XP card, when an XFP is plugged into it, implements the Cisco Standard Security Code Check Algorithm that keys on vendor ID and serial number.

If a PPM is plugged into a port on the card but fails the security code check because it is not a Cisco PPM, a NON-CISCO-PPM Not Reported (NR) condition occurs.

If a PPM with a nonqualified product ID is plugged into a port on this card, that is, the PPM passes the security code as a Cisco PPM but it has not been qualified for use on the OTU2_XP card, a UNQUAL-PPM NR condition occurs.

10.14.9 Automatic Laser Shutdown

The ALS procedure is supported on both client and trunk interfaces. On the client interface, ALS is compliant with ITU-T G.664 (6/99). On the data application and trunk interface, the switch on and off pulse duration is greater than 60 seconds. The on and off pulse duration is user-configurable. For details on ALS provisioning for the card, refer to the *Cisco ONS 15454 DWDM Procedure Guide*.

10.14.10 ODU Transparency

A key feature of the OTU2_XP card is the ability to configure the ODU overhead bytes (EXP bytes and RES bytes 1 and 2) using the ODU Transparency parameter. The two options available for this parameter are:

- **Transparent Standard Use**—ODU overhead bytes are transparently passed through the card. This option allows the OTU2_XP card to act transparently between two trunk ports (when the card is configured in Standard Regen or Enhanced FEC).
- **Cisco Extended Use**—ODU overhead bytes are terminated and regenerated on both ports of the regenerator group.

The ODU Transparency parameter is configurable only for Standard Regen and Enhanced FEC card configuration. For Transponder card configuration, this parameter defaults to Cisco Extended Use and cannot be changed.

**Note**

The Forward Error Correction (FEC) Mismatch (FEC-MISM) alarm will not be raised on OTU2_XP card when you choose Transparent Standard Use.

10.14.11 Protection

The OTU2_XP card supports Y-cable and splitter protection. Y-cable protection is provided at the client port level. Splitter protection is provided at the trunk port level.

10.14.11.1 Y-Cable Protection

The OTU2_XP card supports Y-cable protection on client ports when it is provisioned in the transponder card configuration. Two cards can be joined in a Y-cable protection group with one card assigned as the working card and the other defined as the protection card. This protection mechanism provides redundant bidirectional paths. See the “[10.19.1 Y-Cable Protection](#)” section on page 10-140 for more detailed information. When a signal fault is detected (LOS, LOF, SD, or SF on the DWDM receiver port in the case of ITU-T G.709 mode) the protection mechanism software automatically switches between paths.

**Note**

When the 10G Ethernet LAN Phy to WAN Phy conversion feature is enabled, Y-cable protection is not supported on the LAN to WAN interface (ports 1 and 3).

10.14.11.2 Splitter Protection

The OTU2_XP card supports splitter protection on trunk ports that are not part of a regenerator group (see [Table 10-50](#) for port details). You can create and delete splitter protection groups in OTU2_XP card. In splitter protection method, a client injects a single signal into the client RX port. An optical splitter internal to the card then splits the signal into two separate signals and routes them to the two trunk TX ports. See the “[10.19.2 Splitter Protection](#)” section on page 10-142 for more detailed information.

In the splitter protected 10G Ethernet LAN Phy to WAN Phy mode, AIS-P and LOP-P acts as trigger (when G.709 is enabled) for the Protection Switch, in addition to the existing switching criteria.

The STS parameters such as, SF /SD thresholds, Path PM thresholds, and Path Trace is set for the working path (Port 3). The same parameters are also applicable for the protected path (Port 4).

10.15 MLSE UT

The maximum likelihood sequence estimation (MLSE) based universal transponder (UT) modules are added to the TXP_MR_10EX_C, MXP_2.5G_10EX_C, and MXP_MR_10DMEX_C cards to support the error decorrelator functionality to enhance system performance.

10.15.1 Error Decorrelator

The MLSE feature uses the error decorrelator functionality to reduce the chromatic dispersion (CD) and polarization mode dispersion (PMD), thereby extending the transmission range on the trunk interface. You can enable or disable the error decorrelator functionality using CTC or TL1. The dispersion compensation unit (DCU) is also used to reduce CD and PMD. The MLSE-based UT module helps to reduce CD and PMD without the use of a DCU.

10.16 TXP_MR_10EX_C Card

The TXP_MR_10EX_C card is a multirate transponder for the ONS 15454 platform. The card is fully backward compatible with TXP_MR_10E_C cards (only when the error decorrelator is disabled in the CTC on the TXP_MR_10EX_C card). It processes one 10-Gbps signal (client side) into one 10-Gbps, 100-GHz DWDM signal (trunk side). The TXP_MR_10EX_C card is tunable over the 82 channels of C-band (82 channels spaced at 50 GHz on the ITU grid).

You can install TXP_MR_10EX_C card in Slots 1 to 6 and 12 to 17. The card can be provisioned in linear, BLSR/MS-SPRing, path protection/SNCP configurations or as a regenerator. The card can be used in the middle of BLSR/MS-SPRing or 1+1 spans when the card is configured for transparent termination mode. The TXP_MR_10EX_C card features an MLSE-based Universal Transponder 1550-nm tunable laser and a separately orderable ONS-XC-10G-S1 1310-nm or ONS-XC-10G-L2 1550-nm laser XFP module for the client port.



Note

The PRE FEC BER performance of the TXP_MR_10EX_C card may be significantly low when compared to the TXP_MR_10E card. However, this does not affect the Post FEC BER performance, but could possibly affect any specific monitoring application that relies on the PRE FEC BER value (for example, protection switching). In this case, the replacement of TXP_MR_10E card with the TXP_MR_10EX_C may not work properly.



Note

When the ONS-XC-10G-L2 XFP is installed, the TXP_MR_10EX_C card must be installed in a high-speed slot (slot 6, 7, 12, or 13)

On its faceplate, the TXP_MR_10EX_C card contains two transmit and receive connector pairs, one for the trunk port and one for the client port. Each connector pair is labeled.

10.16.1 Key Features

The key features of the TXP_MR_10EX_C card are:

- A multi-rate client interface (available through the ONS-XC-10G-S1 XFP, ordered separately):

- OC-192 (SR1)
 - 10GE (10GBASE-LR)
 - 10G-FC (1200-SM-LL-L)
 - (ONS-XC-10G-S1 version 3 only) IB_5G
- An MLSE-based UT module tunable through 82 channels of C-band. The channels are spaced at 50 GHz on the ITU grid.
 - OC-192 to ITU-T G.709 OTU2 provisionable synchronous and asynchronous mapping.
 - Proprietary rate at the trunk when the client is provisioned as IB_5G.
 - The MTU setting is used to display the OverSizePkts counters on the receiving trunk and client port interfaces. Traffic of frame sizes up to 65535 bytes pass without any packet drops, from the client port to the trunk port and vice versa irrespective of the MTU setting.

10.16.2 Faceplate and Block Diagram

Figure 10-34 shows the TXP_MR_10EX_C faceplate and block diagram.

Figure 10-34 TXP_MR_10EX_C Faceplate and Block Diagram

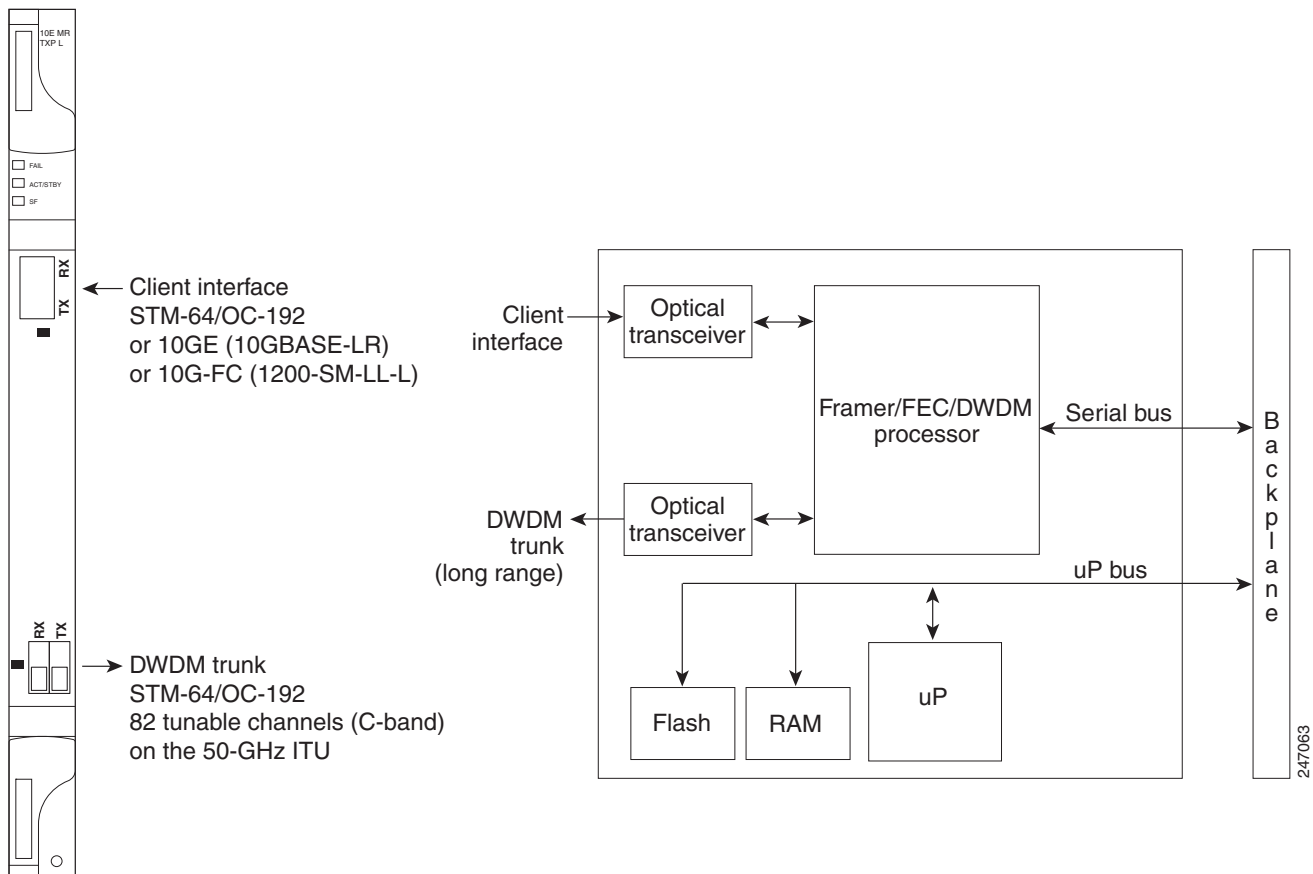

For information on safety labels for the card, see the “10.2.2 Class 1M Laser Product Cards” section on page 10-11.

**Caution**

You must use a 15-dB fiber attenuator (10 to 20 dB) when working with the TXP_MR_10EX_C card in a loopback on the trunk port. Do not use direct fiber loopbacks with this card, because they can cause irreparable damage to the card.

10.16.3 Client Interface

The client interface is implemented with a separately orderable XFP module. The module is a tri-rate transceiver, providing a single port that can be configured in the field to support an OC-192 SR-1 (Telcordia GR-253-CORE) or STM-64 I-64.1 (ITU-T G.691) optical interface, as well as 10GE LAN PHY (10GBASE-LR), 10GE WAN PHY (10GBASE-LW), 10G-FC signals, or IB_5G signals.

The client-side XFP pluggable module supports LC connectors and is equipped with a 1310-nm laser.

10.16.4 DWDM Trunk Interface

On the trunk side, the TXP_MR_10EX_C card provides a 10-Gbps STM-64/OC-192 interface. In the 1550-nm C-band on the 50-GHz ITU grid for the DWDM interface, 82 tunable channels are available. The TXP_MR_10EX_C card provides 3R transponder functionality for this 10-Gbps trunk interface. Therefore, the card is suited for use in long-range amplified systems. The DWDM interface is compliant with ITU-T G.707, ITU-T G.709, and Telcordia GR-253-CORE standards.

The DWDM trunk port operates at a rate that depends on the input signal and the presence of the ITU-T G.709 Digital Wrapper/FEC. The possible trunk rates are:

- OC192 (9.95328 Gbps)
- OTU2 (10.70923 Gbps)
- 10GE (10.3125 Gbps) or 10GE into OTU2 (ITU G.sup43 11.0957 Gbps)
- 10G-FC (10.51875 Gbps) or 10G-FC into OTU2 (nonstandard 11.31764 Gbps)
- Proprietary rate at the trunk when the client is provisioned as IB_5G.

The maximum system reach in filterless applications without the use of optical amplification or regenerators is nominally rated at 23 dB over C-SMF fiber. This rating is not a product specification, but is given for informational purposes. It is subject to change.

**Note**

You cannot disable ITU-T G.709 on the trunk side. If ITU-T G.709 is enabled, then FEC cannot be disabled.

10.16.5 Enhanced FEC (E-FEC) Feature

A key feature of the TXP_MR_10EX_C card is the availability to configure the forward error correction feature in two modes: FEC and E-FEC. The output bit rate is always 10.7092 Gbps as defined in ITU-T G.709, but the error coding performance can be provisioned as follows:

- FEC—Standard ITU-T G.975 Reed-Solomon algorithm
- E-FEC—Standard ITU-T G.975.1 I.7 algorithm, (a super FEC code)

10.16.6 FEC and E-FEC Modes

As client-side traffic passes through the TXP_MR_10EX_C card, it can be digitally wrapped using FEC mode or E-FEC mode. The FEC mode setting provides a lower level of error detection and correction than the E-FEC mode setting of the card. As a result, using E-FEC mode allows higher sensitivity (lower OSNR) with a lower bit error rate than FEC mode. E-FEC enables longer distance trunk-side transmission than with FEC.

The E-FEC feature is one of three basic modes of FEC operation. FEC can be turned on, or E-FEC can be turned on to provide greater range and lower BER. The default mode is FEC on and E-FEC off. E-FEC is provisioned using CTC.



Caution

Because the transponder has no visibility into the data payload and detect circuits, the TXP_MR_10EX_C card does not display circuits under the card view.

10.16.7 Client-to-Trunk Mapping

The TXP_MR_10EX_C card can perform ODU2-to-OCh mapping, which allows operators to provision data payloads in a standard way across 10-Gbps optical links.

Digital wrappers that define client-side interfaces are called ODU2 entities in ITU-T G.709. Digital wrappers that define trunk-side interfaces are called OCh in ITU-T G.709. ODU2 digital wrappers can include G-MPLS signaling extensions to ITU-T G.709 (such as LSP and G-PID values) to define client interfaces and payload protocols.

10.16.8 Automatic Laser Shutdown

The ALS procedure is supported on both client and trunk interfaces. On the client interface, ALS is compliant with ITU-T G.664 (6/99). On the data application and trunk interface, the switch on and off pulse duration is greater than 60 seconds and is user-configurable. For details regarding ALS provisioning for the TXP_MR_10EX_C card, refer to the *Cisco ONS 15454 DWDM Procedure Guide*.

10.16.9 TXP_MR_10EX_C Card-Level Indicators

Table 10-55 lists the card-level LEDs on the TXP_MR_10EX_C card.

Table 10-55 TXP_MR_10EX_C Card-Level Indicators

Card-Level LED	Description
Red FAIL LED	The red FAIL LED indicates that the card's processor is not ready. This LED is on during reset. The FAIL LED flashes during the boot process. Replace the card if the red FAIL LED persists.

Table 10-55 TXP_MR_10EX_C Card-Level Indicators (continued)

Card-Level LED	Description
ACT/STBY LED Green (Active) Amber (Standby)	If the ACT/STBY LED is green, the card is operational (one or both ports active) and ready to carry traffic. If the ACT/STBY LED is amber, the card is operational and in standby (protect) mode.
Amber SF LED	The amber SF LED indicates a signal failure or condition such as LOS, LOF, or high BERs on one or more of the card's ports. The amber SF LED is also on if the transmit and receive fibers are incorrectly connected. If the fibers are properly connected and the link is working, the light turns off.

10.16.10 TXP_MR_10EX_C Port-Level Indicators

Table 10-56 lists the port-level LEDs on the TXP_MR_10EX_C card.

Table 10-56 TXP_MR_10EX_C Port-Level Indicators

Port-Level LED	Description
Green Client LED	The green Client LED indicates that the client port is in service and that it is receiving a recognized signal.
Green DWDM LED	The green DWDM LED indicates that the DWDM port is in service and that it is receiving a recognized signal.

10.17 MXP_2.5G_10EX_C card

The MXP_2.5G_10EX_C card is a DWDM muxponder for the ONS 15454 platform that supports transparent termination mode on the client side. The faceplate designation of the card is “4x2.5G 10EX MXP.” The card multiplexes four 2.5-Gbps client signals (4xOC48/STM-16 SFP) into a single 10-Gbps DWDM optical signal on the trunk side. The card provides wavelength transmission service for the four incoming 2.5-Gbps client interfaces. The MXP_2.5G_10EX_C muxponder passes all SONET/SDH overhead bytes transparently.

The digital wrapper function (ITU-T G.709 compliant) formats the DWDM wavelength so that it can be used to set up GCCs for data communications, enable FEC, or facilitate PM.

The MXP_2.5G_10EX_C card works with OTN devices defined in ITU-T G.709. The card supports ODU1 to OTU2 multiplexing, an industry standard method for asynchronously mapping a SONET/SDH payload into a digitally wrapped envelope. See the “10.8.5 Multiplexing Function” section on page 10-44.

The MXP_2.5G_10EX_C card is not compatible with the MXP_2.5G_10G card, which does not support transparent termination mode.

You can install the MXP_2.5G_10EX_C card in slots 1 to 6 and 12 to 17. You can provision a card in a linear configuration, a BLSR/MS-SPRing, a path protection/SNCP, or a regenerator. The card can be used in the middle of BLSR/MS-SPRing or 1+1 spans when the card is configured for transparent termination mode.

The MXP_2.5G_10EX_C card features a tunable 1550-nm C-band laser on the trunk port. The laser is tunable across 82 wavelengths on the ITU grid with 50-GHz spacing between wavelengths. The card features four 1310-nm lasers on the client ports and contains five transmit and receive connector pairs

(labeled) on the card faceplate. The card uses dual LC connectors on the trunk side and SFP modules on the client side for optical cable termination. The SFP pluggable modules are SR or IR and support an LC fiber connector.

**Note**

When you create a 4xOC-48 OCHCC circuit, you need to select the G.709 and Synchronous options. A 4xOC-48 OCHCC circuit is supported by G.709 and synchronous mode, which are necessary to provision the 4xOC-48 OCHCC circuit.

10.17.1 Key Features

The MXP_2.5G_10EX_C card has the following high-level features:

- Four 2.5-Gbps client interfaces (OC-48/STM-16) and one 10-Gbps trunk. The four OC-48 signals are mapped into an ITU-T G.709 OTU2 signal using standard ITU-T G.709 multiplexing.
- Onboard E-FEC processor: The processor supports both standard RS (specified in ITU-T G.709) and E-FEC, which allows an improved gain on trunk interfaces with a resultant extension of the transmission range on these interfaces. The E-FEC functionality increases the correction capability of the transponder to improve performance, allowing operation at a lower OSNR compared to the standard RS (237,255) correction algorithm.
- Pluggable client-interface optic modules: The MXP_2.5G_10EX_C card has modular interfaces. Two types of optic modules can be plugged into the card. These modules include an OC-48/STM-16 SR-1 interface with a 7-km (4.3-mile) nominal range (for short range and intra-office applications) and an IR-1 interface with a range of up to 40 km (24.9 miles). SR-1 is defined in Telcordia GR-253-CORE and in I-16 (ITU-T G.957). IR-1 is defined in Telcordia GR-253-CORE and in S-16-1 (ITU-T G.957).
- High-level provisioning support: The card is initially provisioned using Cisco TransportPlanner software. Subsequently, the card can be monitored and provisioned using CTC software.
- Link monitoring and management: The card uses standard OC-48 OH (overhead) bytes to monitor and manage incoming interfaces. The card passes the incoming SDH/SONET data stream and its overhead bytes transparently.
- Control of layered SONET/SDH transport overhead: The card is provisionable to terminate regenerator section overhead, which eliminates forwarding of unneeded layer overhead. It can help reduce the number of alarms and help isolate faults in the network.
- Automatic timing source synchronization: The MXP_2.5G_10EX_C card normally synchronizes from the TCC2/TCC2P/TCC3/TNC/TSC card. If for some reason, such as maintenance or upgrade activity, the TCC2/TCC2P/TCC3/TNC/TSC is not available, the card automatically synchronizes to one of the input client-interface clocks.
- Configurable squelching policy: The card can be configured to squelch the client interface output if LOS occurs at the DWDM receiver or if a remote fault occurs. In the event of a remote fault, the card manages MS-AIS insertion.
- The card is tunable across the full C-band, thus eliminating the need to use different versions of each card to provide tunability across specific wavelengths in a band.
- The MTU setting is used to display the `ifInErrors` and `OverSizePkts` counters on the receiving trunk and client port interfaces. Traffic of frame sizes up to 65535 bytes pass without any packet drops, from the client port to the trunk port and vice versa irrespective of the MTU setting.

10.17.2 Faceplate

Figure 10-35 shows the MXP_2.5G_10EX_C faceplate and block diagram.

Figure 10-35 MXP_2.5G_10EX_C Faceplate and Block Diagram

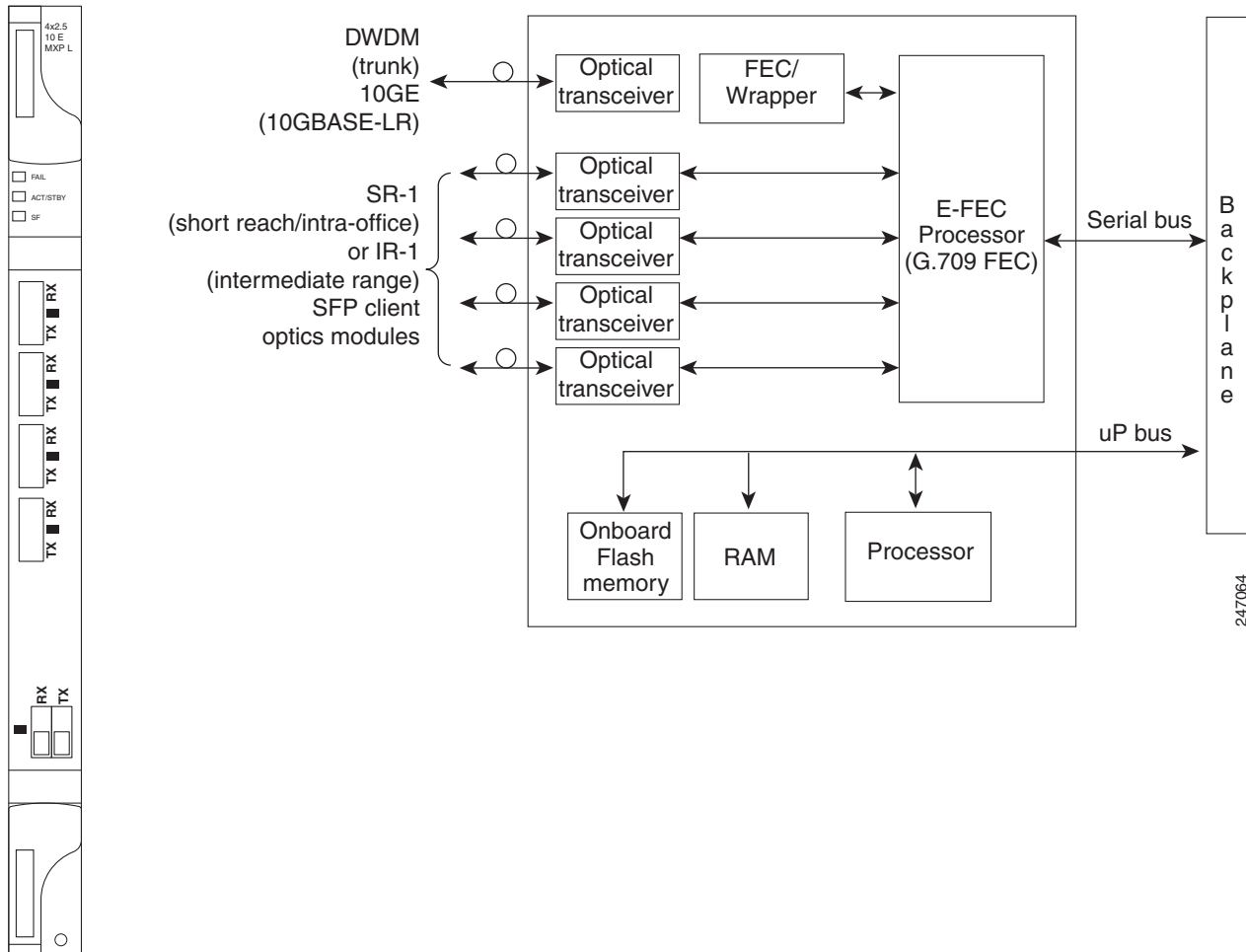

For information on safety labels for the card, see the “10.2.1 Class 1 Laser Product Cards” section on page 10-9.

10.17.3 Client Interfaces

The MXP_2.5G_10EX_C card provides four intermediate- or short-range OC-48/STM-16 ports per card on the client side. Both SR-1 and IR-1 optics can be supported and the ports use SFP connectors. The client interfaces use four wavelengths in the 1310-nm, ITU 100-GHz-spaced, channel grid.

10.17.4 DWDM Interface

The MXP_2.5G_10EX_C card serves as OTN multiplexers, transparently mapping four OC-48 channels asynchronously to ODU1 into one 10-Gbps trunk. For the MXP_2.5G_10EX_C card, the DWDM trunk is tunable for transmission over the entire C-band. Channels are spaced at 50-GHz on the ITU grid.

**Caution**

You must use a 20-dB fiber attenuator (15 to 25 dB) when working with the card in a loopback on the trunk port. Do not use direct fiber loopbacks with the card, because they can cause irreparable damage to the MXP_2.5G_10EX_C card.

**Note**

You cannot disable ITU-T G.709 on the trunk side. If ITU-T G.709 is enabled, then FEC cannot be disabled.

10.17.5 Multiplexing Function

The muxponder is an integral part of the ROADM network. The key function of the MXP_2.5G_10EX_C card is to multiplex four OC-48/STM-16 signals onto one ITU-T G.709 OTU2 optical signal (DWDM transmission). The multiplexing mechanism allows the signal to be terminated at a far-end node by another similar card.

Transparent termination on the muxponder is configured using OTU_x and ODU_x OH bytes. The ITU-T G.709 specification defines OH byte formats that are used to configure, set, and monitor frame alignment, FEC mode, section monitoring, tandem connection monitoring, and transparent termination mode.

The MXP_2.5G_10EX_C card performs ODU to OTU multiplexing as defined in ITU-T G.709. The ODU is the framing structure and byte definition (ITU-T G.709 digital wrapper) used to define the data payload coming into one of the SONET/SDH client interfaces on the card. The term ODU1 refers to an ODU that operates at 2.5-Gbps line rate. On the card, four client interfaces can be defined using ODU1 framing structure and format by asserting an ITU-T G.709 digital wrapper.

The output of the muxponder is a single 10-Gbps DWDM trunk interface defined using OTU2. It is within the OTU2 framing structure that FEC or E-FEC information is appended to enable error checking and correction.

10.17.6 Timing Synchronization

The MXP_2.5G_10EX_C card is synchronized to the TCC2/TCC2P/TCC3/TNC/TSC clock during normal conditions and transmits the ITU-T G.709 frame using this clock. No holdover function is implemented. If neither TCC2/TCC2P/TCC3/TNC/TSC clock is available, the card switches automatically (hitless) to the first of the four valid client clocks with no time restriction as to how long it can run on this clock. The card continues to monitor the TCC2/TCC2P/TCC3/TNC/TSC card. If a TCC2/TCC2P/TCC3/TNC/TSC card is restored to working order, the card reverts to the normal working mode of running from the TCC2/TCC2P/TCC3/TNC/TSC clock. If no valid TCC2/TCC2P/TCC3/TNC/TSC clock is available and all of the client channels become invalid, the card waits (no valid frames processed) until one of the TCC2/TCC2P/TCC3/TNC/TSC cards supplies a valid clock. In addition, the card is allowed to select the recovered clock from one active and valid client channel and supply that clock to the TCC2/TCC2P/TCC3/TNC/TSC card.

10.17.7 Enhanced FEC (E-FEC) Capability

The MXP_2.5G_10EX_C card can configure the FEC in two modes: FEC and E-FEC. The output bit rate is always 10.7092 Gbps as defined in ITU-T G.709, but the error coding performance can be provisioned as follows:

- FEC—Standard ITU-T G.975 Reed-Solomon algorithm
- E-FEC—Standard ITU-T G.975.1 I.7, two orthogonally concatenated BCH super FEC codes. This FEC scheme contains three parameterizations of the same scheme of two orthogonally interleaved block codes (BCH). The constructed code is decoded iteratively to achieve the expected performance.

10.17.8 FEC and E-FEC Modes

As client-side traffic passes through the card, it can be digitally wrapped using FEC mode error correction or E-FEC mode error correction. The FEC mode setting provides a lower level of error detection and correction than the E-FEC mode setting of the card. As a result, using E-FEC mode allows higher sensitivity (lower OSNR) with a lower BER than FEC mode. E-FEC enables longer distance trunk-side transmission than with FEC.

The E-FEC feature is one of three basic modes of FEC operation. FEC can be turned on, or E-FEC can be turned on to provide greater range and lower BER. The default mode is FEC on and E-FEC off. E-FEC is provisioned using CTC.

10.17.9 SONET/SDH Overhead Byte Processing

The card passes the incoming SONET/SDH data stream and its overhead bytes for the client signal transparently. The card can be provisioned to terminate regenerator section overhead, which eliminates forwarding of unneeded layer overhead. It can help reduce the number of alarms and help isolate faults in the network.

10.17.10 Client Interface Monitoring

The following parameters are monitored on the MXP_2.5G_10EX_C card:

- Laser bias current is measured as a PM parameter.
- LOS is detected and signaled.
- Rx and Tx power are monitored.

The following parameters are monitored in real-time mode (one second):

- Optical power transmitted (client)
- Optical power received (client)

In the case of LOC at the DWDM receiver or far-end LOS, the client interface behavior is configurable. AIS can be invoked or the client signal can be squelched.

10.17.11 Wavelength Identification

The card uses trunk lasers that are wavelocked, which allows the trunk transmitter to operate on the ITU grid effectively. The MXP_2.5G_10EX_C card implements the MLSE-based UT module. The MXP_2.5G_10EX_C card uses a C-band version of the UT2.

Table 10-57 describes the required trunk transmit laser wavelengths for the MXP_2.5G_10EX_C card. The laser is tunable over 82 wavelengths in the C-band at 50-GHz spacing on the ITU grid.

Table 10-57 MXP_2.5G_10EX_C Trunk Wavelengths

Channel Number	Frequency (THz)	Wavelength (nm)	Channel Number	Frequency (THz)	Wavelength (nm)
1	196.00	1529.55	42	193.95	1545.72
2	195.95	1529.94	43	193.90	1546.119
3	195.90	1530.334	44	193.85	1546.518
4	195.85	1530.725	45	193.80	1546.917
5	195.80	1531.116	46	193.75	1547.316
6	195.75	1531.507	47	193.70	1547.715
7	195.70	1531.898	48	193.65	1548.115
8	195.65	1532.290	49	193.60	1548.515
9	195.60	1532.681	50	193.55	1548.915
10	195.55	1533.073	51	193.50	1549.32
11	195.50	1533.47	52	193.45	1549.71
12	195.45	1533.86	53	193.40	1550.116
13	195.40	1534.250	54	193.35	1550.517
14	195.35	1534.643	55	193.30	1550.918
15	195.30	1535.036	56	193.25	1551.319
16	195.25	1535.429	57	193.20	1551.721
17	195.20	1535.822	58	193.15	1552.122
18	195.15	1536.216	59	193.10	1552.524
19	195.10	1536.609	60	193.05	1552.926
20	195.05	1537.003	61	193.00	1553.33
21	195.00	1537.40	62	192.95	1553.73
22	194.95	1537.79	63	192.90	1554.134
23	194.90	1538.186	64	192.85	1554.537
24	194.85	1538.581	65	192.80	1554.940
25	194.80	1538.976	66	192.75	1555.343
26	194.75	1539.371	67	192.70	1555.747
27	194.70	1539.766	68	192.65	1556.151
28	194.65	1540.162	69	192.60	1556.555
29	194.60	1540.557	70	192.55	1556.959

Table 10-57 MXP_2.5G_10EX_C Trunk Wavelengths (continued)

Channel Number	Frequency (THz)	Wavelength (nm)	Channel Number	Frequency (THz)	Wavelength (nm)
30	194.55	1540.953	71	192.50	1557.36
31	194.50	1541.35	72	192.45	1557.77
32	194.45	1541.75	73	192.40	1558.173
33	194.40	1542.142	74	192.35	1558.578
34	194.35	1542.539	75	192.30	1558.983
35	194.30	1542.936	76	192.25	1559.389
36	194.25	1543.333	77	192.20	1559.794
37	194.20	1543.730	78	192.15	1560.200
38	194.15	1544.128	79	192.10	1560.606
39	194.10	1544.526	80	192.05	1561.013
40	194.05	1544.924	81	192.00	1561.42
41	194.00	1545.32	82	191.95	1561.83

10.17.12 Automatic Laser Shutdown

The ALS procedure is supported on both client and trunk interfaces. On the client interface, ALS is compliant with ITU-T G.664 (6/99). On the data application and trunk interface, the switch on and off pulse duration is greater than 60 seconds and is user-configurable. For details regarding ALS provisioning for the MXP_2.5G_10EX_C card, see the *Cisco ONS 15454 DWDM Procedure Guide*.

10.17.13 Jitter

For SONET and SDH signals, the MXP_2.5G_10EX_C card complies with Telcordia GR-253-CORE, ITU-T G.825, and ITU-T G.873 for jitter generation, jitter tolerance, and jitter transfer. See the [“10.21 Jitter Considerations” section on page 10-143](#) for more information.

10.17.14 Lamp Test

The MXP_2.5G_10EX_C card supports a lamp test function that is activated from the ONS 15454 front panel or through CTC to ensure that all LEDs are functional.

10.17.15 Onboard Traffic Generation

The MXP_2.5G_10EX_C card provides internal traffic generation for testing purposes according to PRBS, SONET/SDH, or ITU-T G.709.

10.17.16 MXP_2.5G_10EX_C Card-Level Indicators

Table 10-58 describes the card-level LEDs on the MXP_2.5G_10EX_C card.

Table 10-58 MXP_2.5G_10EX_C Card-Level Indicators

Card-Level LED	Description
Red FAIL LED	The red FAIL LED indicates that the card's processor is not ready. This LED is on during reset. The FAIL LED flashes during the boot process. Replace the card if the red FAIL LED persists.
ACT/STBY LED Green (Active) Amber (Standby)	If the ACT/STBY LED is green, the card is operational (one or more ports active) and ready to carry traffic. If the ACT/STBY LED is amber, the card is operational and in standby (protect) mode.
Amber SF LED	The amber SF LED indicates a signal failure or condition such as LOS, LOF, or high BERs on one or more of the card's ports. The amber SF LED is also on if the transmit and receive fibers are incorrectly connected. If the fibers are properly connected and the link is working, the light turns off.

10.17.17 MXP_2.5G_10EX_C Port-Level Indicators

Table 10-59 describes the port-level LEDs on the MXP_2.5G_10EX_C card.

Table 10-59 MXP_2.5G_10E_C and MXP_2.5G_10E_L Port-Level Indicators

Port-Level LED	Description
Green Client LED (four LEDs)	A green Client LED indicates that the client port is in service and that it is receiving a recognized signal. The card has four client ports, and so has one Client LED for each port.
Green DWDM LED	The green DWDM LED indicates that the DWDM port is in service and that it is receiving a recognized signal.

10.18 MXP_MR_10DMEX_C Card

The MXP_MR_10DMEX_C card aggregates a mix of client SAN service-client inputs (GE, FICON, and Fibre Channel) into one 10-Gbps STM-64/OC-192 DWDM signal on the trunk side. It provides one long-reach STM-64/OC-192 port per card and is compliant with Telcordia GR-253-CORE and ITU-T G.957.

The card supports aggregation of the following signal types:

- 1-Gigabit Fibre Channel
- 2-Gigabit Fibre Channel
- 4-Gigabit Fibre Channel
- 1-Gigabit Ethernet
- 1-Gigabit ISC-Compatible (ISC-1)
- 2-Gigabit ISC-Peer (ISC-3)

**Caution**

The card can be damaged by dropping it. Handle it carefully.

The MXP_MR_10DMEX_C muxponder passes all SONET/SDH overhead bytes transparently.

The digital wrapper function (ITU-T G.709 compliant) formats the DWDM wavelength so that it can be used to set up GCCs for data communications, enable FEC, or facilitate PM. The MXP_MR_10DMEX_C card works with the OTN devices defined in ITU-T G.709. The card supports ODU1 to OTU2 multiplexing, an industry standard method for asynchronously mapping a SONET/SDH payload into a digitally wrapped envelope. See the “[10.7.7 Multiplexing Function](#)” section on [page 10-36](#).

**Note**

You cannot disable ITU-T G.709 on the trunk side. If ITU-T G.709 is enabled, then FEC cannot be disabled.

**Note**

Because the client payload cannot oversubscribe the trunk, a mix of client signals can be accepted, up to a maximum limit of 10 Gbps.

You can install the MXP_MR_10DMEX_C card in slots 1 to 6 and 12 to 17.

**Note**

The MXP_MR_10DMEX_C card is not compatible with the MXP_2.5G_10G card, which does not support transparent termination mode.

The MXP_MR_10DMEX_C card features a tunable 1550-nm C-band laser on the trunk port. The laser is tunable across 82 wavelengths on the ITU grid with 50-GHz spacing between wavelengths. Each card features four 1310-nm lasers on the client ports and contains five transmit and receive connector pairs (labeled) on the card faceplate. The card uses dual LC connectors on the trunk side and SFP modules on the client side for optical cable termination. The SFP pluggable modules are SR or IR and support an LC fiber connector.

[Table 10-60](#) shows the input data rate for each client interface, and the encapsulation method. The current version of the GFP-T G.7041 supports transparent mapping of 8B/10B block-coded protocols, including Gigabit Ethernet, Fibre Channel, ISC, and FICON.

In addition to the GFP mapping, 1-Gbps traffic on Port 1 or 2 of the high-speed SERDES is mapped to an STS-24c channel. If two 1-Gbps client signals are present at Port 1 and Port 2 of the high-speed SERDES, the Port 1 signal is mapped into the first STS-24c channel and the Port 2 signal into the second STS-24c channel. The two channels are then mapped into an OC-48 trunk channel.

Table 10-60 MXP_MR_10DMEX_C Client Interface Data Rates and Encapsulation

Client Interface	Input Data Rate	GFP-T G.7041 Encapsulation
2G FC	2.125 Gbps	Yes
1G FC	1.06 Gbps	Yes
2G FICON/2G ISC-Compatible (ISC-1)/ 2G ISC-Peer (ISC-3)	2.125 Gbps	Yes

Table 10-60 MXP_MR_10DMEX_C Client Interface Data Rates and Encapsulation (continued)

Client Interface	Input Data Rate	GFP-T G.7041 Encapsulation
1G FICON/1G ISC-Compatible (ISC-1)/ 1G ISC-Peer (ISC-3)	1.06 Gbps	Yes
Gigabit Ethernet	1.25 Gbps	Yes

The MXP_MR_10DMEX_C card includes two FPGAs, and a group of four ports is mapped to each FPGA. Group 1 consists of Ports 1 through 4, and Group 2 consists of Ports 5 through 8. Table 10-61 shows some of the mix and match possibilities on the various client data rates for Ports 1 through 4, and Ports 5 through 8. An X indicates that the data rate is supported in that port.

Table 10-61 Supported Client Data Rates for Ports 1 through 4 and Ports 5 through 8

Port (Group 1)	Port (Group 2)	Gigabit Ethernet	1G FC	2G FC	4G FC
1	5	X	X	X	X
2	6	X	X	—	—
3	7	X	X	X	—
4	8	X	X	—	—

GFP-T PM is available through RMON and trunk PM is managed according to Telcordia GR-253-CORE and ITU G.783/826. Client PM is achieved through RMON for FC and GE.

A buffer-to-buffer credit management scheme provides FC flow control. With this feature enabled, a port indicates the number of frames that can be sent to it (its buffer credit), before the sender is required to stop transmitting and wait for the receipt of a “ready” indication. The MXP_MR_10DMEX_C card supports FC credit-based flow control with a buffer-to-buffer credit extension of up to 1600 km (994.1 miles) for 1G FC, up to 800 km (497.1 miles) for 2G FC, or up to 400 km (248.5 miles) for 4G FC. The feature can be enabled or disabled.

The MXP_MR_10DMEX_C card features a 1550-nm laser for the trunk/line port and a 1310-nm or 850-nm laser (depending on the SFP) for the client ports. The card contains eight 12.5-degree downward-tilt SFP modules for the client interfaces. For optical termination, each SFP uses two LC connectors, which are labeled TX and RX on the faceplate. The trunk port is a dual-LC connector with a 45-degree downward angle.

10.18.1 Key Features

The MXP_MR_10DMEX_C card has the following high-level features:

- **Onboard E-FEC processor:** The processor supports both standard RS (specified in ITU-T G.709) and E-FEC, which allows an improved gain on trunk interfaces with a resultant extension of the transmission range on these interfaces. The E-FEC functionality increases the correction capability of the transponder to improve performance, allowing operation at a lower OSNR compared to the standard RS (237,255) correction algorithm.
- **Pluggable client-interface optic modules:** The MXP_MR_10DMEX_C card has modular interfaces. Two types of optics modules can be plugged into the card. These modules include an OC-48/STM-16 SR-1 interface with a 7-km (4.3-mile) nominal range (for short range and

intra-office applications) and an IR-1 interface with a range of up to 40 km (24.9 miles). SR-1 is defined in Telcordia GR-253-CORE and in I-16 (ITU-T G.957). IR-1 is defined in Telcordia GR-253-CORE and in S-16-1 (ITU-T G.957).

- Y-cable protection: The card supports Y-cable protection between the same card type only, on ports with the same port number and signal rate. See the “[10.19.1 Y-Cable Protection](#)” section on [page 10-140](#) for more detailed information.
- High-level provisioning support: The card is initially provisioned using Cisco TransportPlanner software. Subsequently, the card can be monitored and provisioned using CTC software.
- ALS: This safety mechanism is used in the event of a fiber cut. For details regarding ALS provisioning for the MXP_MR_10DMEX_C card, refer to the *Cisco ONS 15454 DWDM Procedure Guide*.
- Link monitoring and management: The card uses standard OC-48 OH(overhead) bytes to monitor and manage incoming interfaces. The card passes the incoming SDH/SONET data stream and its OH(overhead) bytes transparently.
- Control of layered SONET/SDH transport overhead: The card is provisionable to terminate regenerator section overhead, which eliminates forwarding of unneeded layer overhead. It can help reduce the number of alarms and help isolate faults in the network.
- Automatic timing source synchronization: The MXP_MR_10DMEX_C card normally synchronizes from the TCC2/TCC2P/TCC3/TNC/TSC card. If for some reason, such as maintenance or upgrade activity, the TCC2/TCC2P/TCC3/TNC/TSC is not available, the card automatically synchronizes to one of the input client-interface clocks.



Note MXP_MR_10DMEX_C card cannot be used for line timing.

- Configurable squelching policy: The card can be configured to squelch the client-interface output if LOS occurs at the DWDM receiver or if a remote fault occurs. In the event of a remote fault, the card manages MS-AIS insertion.
- The card is tunable across the full C-band, thus eliminating the need to use different versions of each card to provide tunability across specific wavelengths in a band.
- You can provision a string (port name) for each fiber channel/FICON interface on the MXP_MR_10DMEX_C card, which allows the MDS Fabric Manager to create a link association between that SAN port and a SAN port on a Cisco MDS 9000 switch.

10.18.2 Faceplate

[Figure 10-36](#) shows the MXP_MR_10DMEX_C faceplate and block diagram.

Figure 10-36 MXP_MR_10DMEX_C Faceplate and Block Diagram

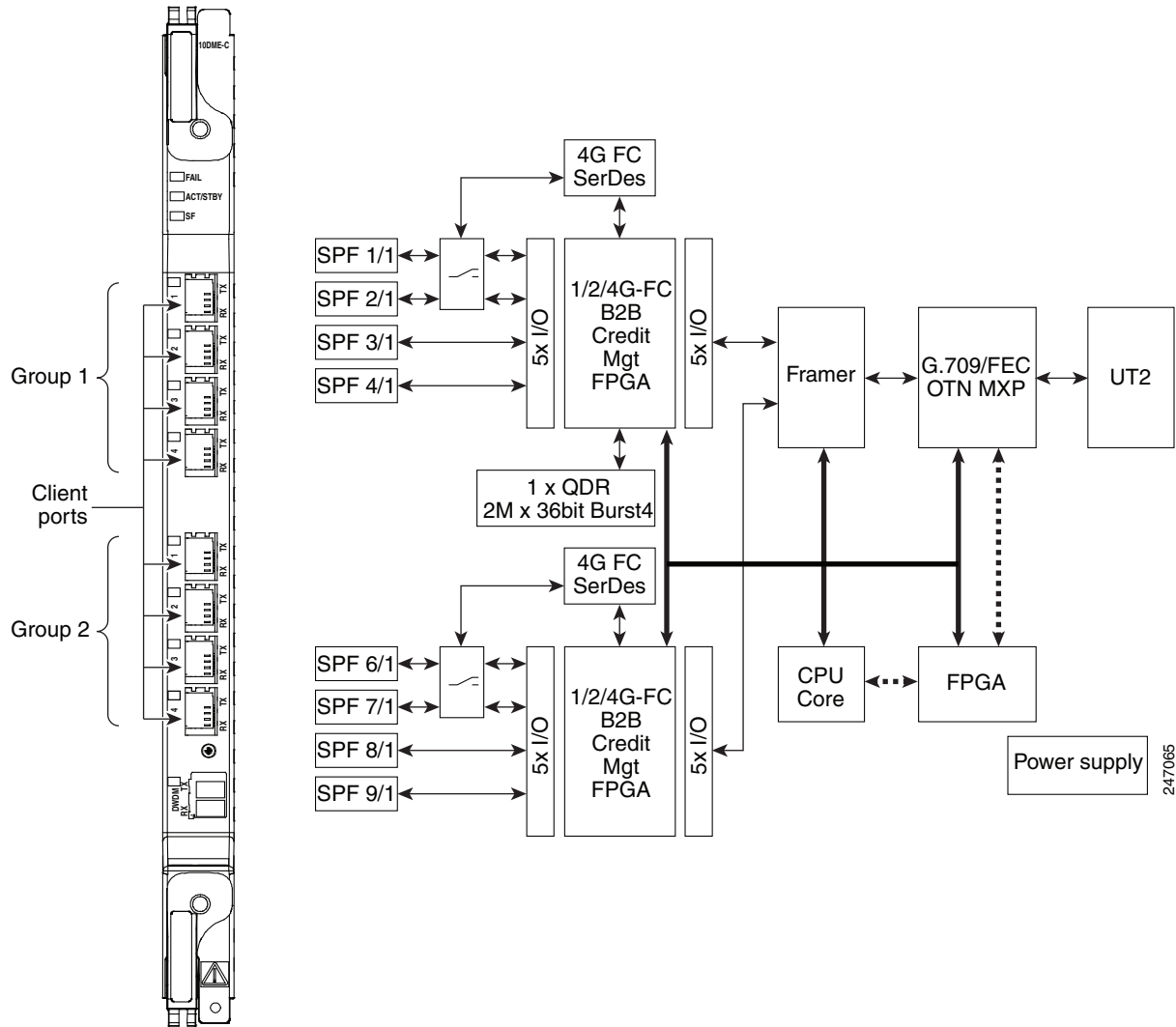

For information on safety labels for the card, see the “10.2.2 Class 1M Laser Product Cards” section on page 10-11.



Caution

You must use a 20-dB fiber attenuator (15 to 25 dB) when working with the card in a loopback on the trunk port. Do not use direct fiber loopbacks with the card, because they can cause irreparable damage to the MXP_MR_10DMEX_C card.

10.18.3 Wavelength Identification

The card uses trunk lasers that are wavelocked, which allows the trunk transmitter to operate on the ITU grid effectively. The MXP_MR_10DMEX_C card uses a C-band version of the MLSE-based UT module.

Table 10-62 describes the required trunk transmit laser wavelengths for the MXP_MR_10DMEX_C card. The laser is tunable over 82 wavelengths in the C-band at 50-GHz spacing on the ITU grid.

Table 10-62 MXP_MR_10DMEX_C Trunk Wavelengths

Channel Number	Frequency (THz)	Wavelength (nm)	Channel Number	Frequency (THz)	Wavelength (nm)
1	196.00	1529.55	42	193.95	1545.72
2	195.95	1529.94	43	193.90	1546.119
3	195.90	1530.334	44	193.85	1546.518
4	195.85	1530.725	45	193.80	1546.917
5	195.80	1531.116	46	193.75	1547.316
6	195.75	1531.507	47	193.70	1547.715
7	195.70	1531.898	48	193.65	1548.115
8	195.65	1532.290	49	193.60	1548.515
9	195.60	1532.681	50	193.55	1548.915
10	195.55	1533.073	51	193.50	1549.32
11	195.50	1533.47	52	193.45	1549.71
12	195.45	1533.86	53	193.40	1550.116
13	195.40	1534.250	54	193.35	1550.517
14	195.35	1534.643	55	193.30	1550.918
15	195.30	1535.036	56	193.25	1551.319
16	195.25	1535.429	57	193.20	1551.721
17	195.20	1535.822	58	193.15	1552.122
18	195.15	1536.216	59	193.10	1552.524
19	195.10	1536.609	60	193.05	1552.926
20	195.05	1537.003	61	193.00	1553.33
21	195.00	1537.40	62	192.95	1553.73
22	194.95	1537.79	63	192.90	1554.134
23	194.90	1538.186	64	192.85	1554.537
24	194.85	1538.581	65	192.80	1554.940
25	194.80	1538.976	66	192.75	1555.343
26	194.75	1539.371	67	192.70	1555.747
27	194.70	1539.766	68	192.65	1556.151
28	194.65	1540.162	69	192.60	1556.555
29	194.60	1540.557	70	192.55	1556.959
30	194.55	1540.953	71	192.50	1557.36
31	194.50	1541.35	72	192.45	1557.77
32	194.45	1541.75	73	192.40	1558.173
33	194.40	1542.142	74	192.35	1558.578

Table 10-62 MXP_MR_10DMEX_C Trunk Wavelengths (continued)

Channel Number	Frequency (THz)	Wavelength (nm)	Channel Number	Frequency (THz)	Wavelength (nm)
34	194.35	1542.539	75	192.30	1558.983
35	194.30	1542.936	76	192.25	1559.389
36	194.25	1543.333	77	192.20	1559.794
37	194.20	1543.730	78	192.15	1560.200
38	194.15	1544.128	79	192.10	1560.606
39	194.10	1544.526	80	192.05	1561.013
40	194.05	1544.924	81	192.00	1561.42
41	194.00	1545.32	82	191.95	1561.83

10.18.4 MXP_MR_10DMEX_C Card-Level Indicators

Table 10-63 describes the card-level LEDs on the MXP_MR_10DMEX_C card.

Table 10-63 MXP_MR_10DMEX_C Card-Level Indicators

Card-Level LED	Description
Red FAIL LED	The red FAIL LED indicates that the card's processor is not ready. This LED is on during reset. The FAIL LED flashes during the boot process. Replace the card if the red FAIL LED persists.
ACT/STBY LED Green (Active) Amber (Standby)	If the ACT/STBY LED is green, the card is operational (one or more ports active) and ready to carry traffic. If the ACT/STBY LED is amber, the card is operational and in standby (protect) mode.
Amber SF LED	The amber SF LED indicates a signal failure or condition such as LOS, LOF, or high BERs on one or more of the card's ports. The amber SF LED is also on if the transmit and receive fibers are incorrectly connected. If the fibers are properly connected and the link is working, the light turns off.

10.18.5 MXP_MR_10DMEX_C Port-Level Indicators

Table 10-64 describes the port-level LEDs on the MXP_MR_10DMEX_C card.

Table 10-64 MXP_MR_10DMEX_C Port-Level Indicators

Port-Level LED	Description
Port LED (eight LEDs, four for each group, one for each SFP)	When green, the port LED indicates that the client port is either in service and receiving a recognized signal (that is, no signal fail), or the port is in Out of Service and Maintenance (OOS,MT or locked, maintenance) state and the signal fail and alarms are being ignored.
Green/Red/Amber/Off	When red, the port LED indicates that the client port is in service but is receiving a signal fail (LOS). When amber, the port LED indicates that the port is provisioned and in a standby state. When off, the port LED indicates that the SFP is either not provisioned, out of service, not properly inserted, or the SFP hardware has failed.
Green DWDM LED	The green DWDM LED indicates that the DWDM port is in service and that it is receiving a recognized signal.

10.19 Y-Cable and Splitter Protection

Y-cable and splitter protection are two main forms of card protection that are available for TXP, MXP, and Xponder (GE_XP, 10GE_XP, GE_XPE, 10GE_XPE, and OTU2_XP) cards when they are provisioned in TXP or MXP mode. Y-cable protection is provided at the client port level. Splitter protection is provided at the trunk port level.



Note

GE_XP, 10GE_XP, GE_XPE, and 10GE_XPE cards use VLAN protection when they are provisioned in L2-over-DWDM mode. For information, see the [“10.12.10.3 Layer 2 Over DWDM Protection”](#) section on page 10-81. The ADM-10G card uses path protection and 1+1 protection. For more information, see the [“10.13.10 Protection”](#) section on page 10-104.

10.19.1 Y-Cable Protection

Y-cable protection is available for the following ONS 15454 TXP, MXP, and Xponder cards:

- TXP_MR_10G
- TXP_MR_10E
- TXP_MR_2.5G
- MXP_2.5G_10G
- MXP_2.5G_10E
- MXP_2.5G_10E_C
- MXP_2.5G_10E_L
- MXP_MR_2.5G
- MXP_MR_10DME_C
- MXP_MR_10DME_L
- 40G-MXP-C

- GE_XP and GE_XPE (when in 10GE or 20GE MXP card mode)
- 10GE_XP and 10GE_XPE (when in 10GE TXP card mode)
- OTU2_XP (when in Transponder card configuration)

To create Y-cable protection, you create a Y-cable protection group for two TXP, MXP, or Xponder cards using the CTC software, then connect the client ports of the two cards physically with a Y-cable. The single client signal is sent into the RX Y-cable and is split between the two TXP, MXP, or Xponder cards. The two TX signals from the client side of the TXP, MXP, or Xponder cards are combined in the TX Y-cable into a single client signal. Only the active card signal passes through as the single TX client signal. The other card must have its laser turned off to avoid signal degradation where the Y-cable joins.

When an MXP_MR_2.5G, MXP_MR_10DME_C, or MXP_MR_10DME_L card that is provisioned with Y-cable protection is used on a storage ISL link (FC1G, FC2G, FC4G, FICON1G, FICON2G, or FICON4G), a protection switchover resets the standby port to active. This reset reinitialises the end-to-end link to avoid any link degradation caused due to loss of buffer credits during switchover and results in an end-to-end traffic hit of 15 to 20 seconds.

When using the MXP_MR_10DME_C or MXP_MR_10DME_L card, enable the fast switch feature and use it with a Cisco MDS storage switch to avoid this 15 to 20 second traffic hit. When enabling fast switch on the MXP_MR_10DME_C or MXP_MR_10DME_L card, ensure that the attached MDS switches have the buffer-to-buffer credit recovery feature enabled.

You can also use the TXP_MR_2.5G card to avoid this 15 to 20 second traffic hit. When a Y-cable protection switchover occurs, the storage ISL link does not reinitialize and results in an end-to-end traffic hit of less than 50ms.

**Note**

Y-cable connectors will not work with copper SFPs because Y-cables are made up of optical connectors and there is no way to physically connect them to a copper SFP. Y-cable protection is not supported on IB_5G.

**Note**

There is a traffic hit of upto a couple hundred milliseconds on the MXP_MR_2.5G and MXP_MR_10DME cards in Y-cable configuration when a fiber cut or SFP failure occurs on one of the client ports.

**Note**

The OTU2_XP and 40E-MXP-C card cannot implement Y-cable protection for the client ports in 10 GE LAN PHY mode. Hence, a pair of OTU2_XP cards is used at each end in pass-through mode (Transponder mode with G.709 disabled) to implement Y-cable protection. The 40E-MXP-CE card can implement Y-cable protection without the OTU2_XP card for the client ports in LAN PHY GFP mode. However, the 40E-MXP-CE card cannot implement Y-cable protection without the OTU2_XP card for the client ports in LAN PHY WIS mode.

**Note**

If you create a GCC on either card of the protect group, the trunk port stays permanently active, regardless of the switch state. When you provision a GCC, you are provisioning unprotected overhead bytes. The GCC is not protected by the protect group.

Figure 10-37 on page 10-142 shows the Y-cable signal flow.

**Note**

Loss of Signal–Payload (LOS-P) alarms, also called Incoming Payload Signal Absent alarms, can occur on a split signal if the ports are not in a Y-cable protection group.

**Note**

Removing an SFP from the client ports of a card in a Y-cable protection group card causes an IMPROPRMVL (PPM) alarm. The working port raises the IMPROPRMVL alarm and the protected port raises the IMPROPRMVL alarm. The severity on the client ports is changed according to the protection switch state.

Figure 10-37 Y-Cable Protection

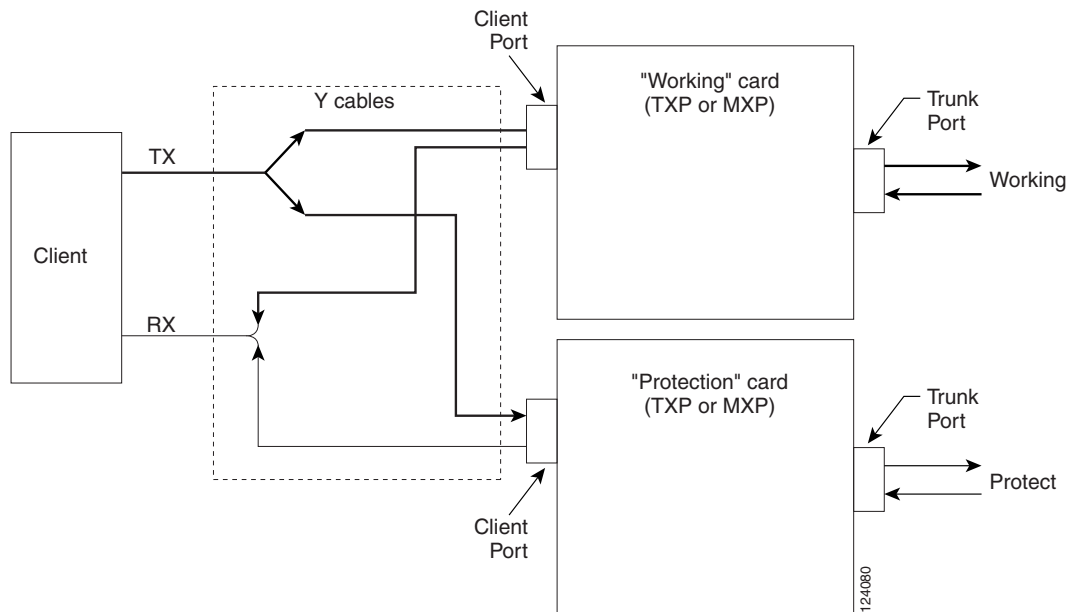

10.19.2 Splitter Protection

Splitter protection, shown in [Figure 10-38](#), is provided with TXPP cards, MXPP cards, and OTU2_XP cards (on trunk ports that are not part of a regenerator group). You can create and delete splitter protection groups in OTU2_XP card.

To implement splitter protection, a client injects a single signal into the client RX port. An optical splitter internal to the card then splits the signal into two separate signals and routes them to the two trunk TX ports. The two signals are transmitted over diverse optical paths. The far-end MXPP or TXPP card uses an optical switch to choose one of the two trunk RX port signals and injects it into the TX client port. When using splitter protection with two MXPP or TXPP cards, there are two different optical signals that flow over diverse paths in each direction. In case of failure, the far-end switch must choose the appropriate signal using its built-in optical switch. The triggers for a protection switch are LOS, LOF, SF, or SD.

Figure 10-38 Splitter Protection

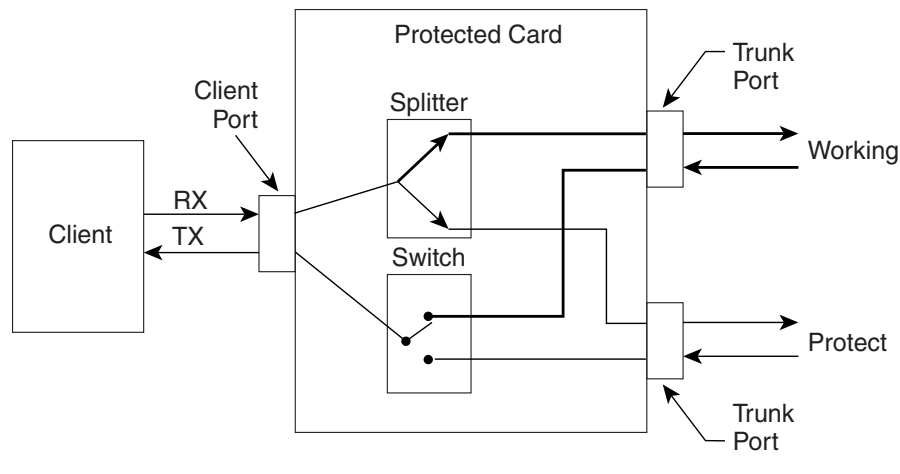

124079

10.20 Far-End Laser Control

The 15454 DWDM cards provide a transparent mode that accurately conveys the client input signal to the far-end client output signal. The client signal is normally carried as payload over the DWDM signals. Certain client signals, however, cannot be conveyed as payload. In particular, client LOS or LOF cannot be carried. Far-end laser control (FELC) is the ability to convey an LOS or LOF from the near-end client input to the far-end client output.

If an LOS is detected on the near-end client input, the near-end trunk sets the appropriate bytes in the OTN overhead of the DWDM line. These bytes are received by the far-end trunk, and cause the far-end client laser to be turned off. When the laser is turned off, it is said to be squelched. If the near-end LOS clears, the near-end trunk clears the appropriate bytes in the OTN overhead, the far-end detects the changed bytes, and the far-end client squelch is removed.

FELC also covers the situation in which the trunk port detects that it has an invalid signal; the client is squelched so as not to propagate the invalid signal.

Payload types with the 2R mode preclude the use of OTN overhead bytes. In 2R mode, an LOS on the client port causes the trunk laser to turn off. The far end detects the LOS on its trunk receiver and squelches the client.

FELC is not provisionable. It is always enabled when the DWDM card is in transparent termination mode. However, FELC signaling to the far-end is only possible when ITU-T G.709 is enabled on both ends of the trunk span.

10.21 Jitter Considerations

Jitter introduced by the SFPs used in the transponders and muxponders must be considered when cascading several cards. With TXP_MR_2.5G, TXPP_MR_2.5G, MXP_MR_2.5G, MXPP_MR_2.5G, and TXP_MR_10E cards, several transponders can be cascaded before the cumulative jitter violates the jitter specification. The recommended limit is 20 cards. With TXP_MR_10G cards, you can also cascade several cards, although the recommended limit is 12 cards. With MXP_2.5G_10G and MXP_2.5G_10E

cards, any number of cards can be cascaded as long as the maximum reach between any two is not exceeded. This is because any time the signal is demultiplexed, the jitter is eliminated as a limiting factor.

The maximum reach between one transponder and the other must be halved if a Y cable is used. For more information on Y-cable operation, see the “10.19.1 Y-Cable Protection” section on page 10-140.

10.22 Termination Modes

Transponder and muxponder cards have various SONET and SDH termination modes that can be configured using CTC (see the “Provision Transponder and Muxponder Cards” chapter in the *Cisco ONS 15454 DWDM Procedure Guide*). The termination modes are summarized in Table 10-65.

Table 10-65 Termination Modes

Cards	Termination Mode	Description
All TXP, MXP, and OTU2_XP cards, with the exception of the MXP_2.5G_10G card (see next section of this table)	Transparent Termination	All the bytes of the payload pass transparently through the cards.
	Section Termination	The SONET transport overhead (TOH) section bytes and the SDH regenerator section overhead (SOH) bytes are terminated. None of these SOH bytes are passed through. They are all regenerated, including the SONET TOH section DCC (SDCC) bytes and the SDH regenerator section DCC (RS-DCC) bytes. In the section termination mode, the SONET TOH line and SDH multiplex section overhead bytes are passed transparently.
	Line Termination	In line termination mode, the section and line overhead bytes for SONET and the overhead bytes for the SDH multiplex and regenerator sections are terminated. None of the overhead bytes are passed through. They are all regenerated, including the SONET SDCC and line DCC (LDCC) bytes and the SDH RS-DCC and multiplexer section DCC (MS-DCC) bytes.
MXP_2.5G_10G ¹	Transparent Termination	All client bytes pass transparently except the following: B1 is rebuilt, S1 is rewritten, A1 to A2 are regenerated, and H1 to H3 are regenerated.
	Section Termination	The SONET TOH section bytes and the SDH regenerator section overhead bytes are terminated. None of these section overhead bytes are passed through. They are all regenerated, including the SONET TOH section DCC bytes and the SDH RS-DCC bytes. In the section termination mode, the SONET TOH line and SDH multiplex section overhead bytes are passed transparently.
	Line Termination	In the line termination mode, the section and line overhead bytes for SONET and the overhead bytes for the SDH multiplex and regenerators sections are terminated. None of the overhead bytes are passed through. They are all regenerated, including the SONET SDCC and LDCC bytes and the SDH RS-DCC and MS-DCC bytes.

1. Clients operating at the OC48/STM16 rate are multiplexed into an OC192/STM64 frame before going to OTN or DWDM.

For TXP and MXP cards, adhere to the following conditions while DCC termination provisioning:

- For SDCC/RS-DCC provisioning, the card should be in the Section/RS-DCC or Line/MS-DCC termination mode.
- For LDCC/MS-DCC provisioning, the card should be in the Line/MS-DCC termination mode.

For more information on enabling termination modes, see the procedures for changing card setting in the “Provision Transponder and Muxponder Cards” chapter of the *Cisco ONS 15454 DWDM Procedure Guide*.

10.23 SFP and XFP Modules

SFPs and 10-Gbps SFPs (XFPs) are integrated fiber optic transceivers that provide high-speed serial links from a port or slot to the network. For more information on SFPs/XFPs and for a list of SFPs/XFPs supported by the transponder and muxponder cards, see the [Installing the GBIC, SFP, SFP+, XFP, CXP, and CFP Optical Modules in Cisco ONS Platforms](#).

In CTC, SFPs/XFPs are called pluggable port modules (PPMs). To provision SFPs/XFPs and change the line rate for multirate PPMs, see the *Cisco ONS 15454 DWDM Procedure Guide*.

