



CHAPTER 13

Optical Channel Circuits and Virtual Patchcords Reference

This chapter explains the Cisco ONS 15454 dense wavelength division multiplexing (DWDM) optical channel (OCH) circuit types and virtual patchcords that can be provisioned on the ONS 15454. Circuit types include the OCH client connection (OCHCC), the OCH trail, and the OCH network connection (OCHNC). Virtual patchcords include internal patchcords and provisionable (external) patchcords (PPCs). This chapter also describes [13.3 End-to-End SVLAN Circuit](#) that can be created between GE_XP, 10GE_XP, GE_XPE, or 10GE_XPE cards.



Note

Unless otherwise specified, “ONS 15454” refers to both ANSI and ETSI shelf assemblies.

13.1 Optical Channel Circuits

The ONS 15454 DWDM optical circuits provide end-to-end connectivity using three OCH circuit types:

- Optical Channel Network Connections (OCHNC)
- Optical Channel Client Connections (OCHCC)
- Optical Channel Trails (OCH Trails)

A graphical representation of OCH circuits is shown in [Figure 13-1](#).

Figure 13-1 Optical Channel Circuits

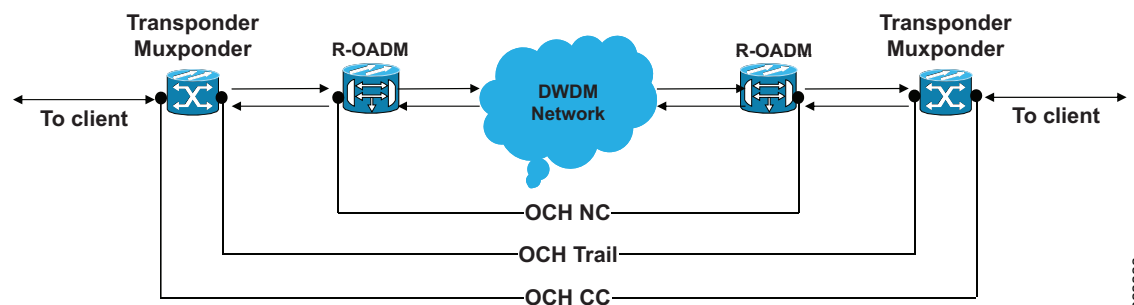

13.1.1 OCHNC Circuits

OCHNC circuits establish connectivity between two optical nodes on a specified C-band wavelength. The connection is made through the ports present on the wavelength selective switches, multiplexers, demultiplexer, and add/drop cards. In an OCHNC circuit, the wavelength from a source OCH port ingresses to a DWDM system and then egresses from the DWDM system to the destination OCH port. The source and destination OCH port details are listed in [Table 13-1](#).

Table 13-1 OCHNC Ports

Card	Source Ports	Destination Ports
32WSS 32WSS-L 40-WSS-C 40-WSS-CE	ADD-RX	—
32MUX-O 40-MUX-C	CHAN-RX	—
32DMX-O 32DMX 32DMX-L 40-DMX-C 40-DMX-CE	—	CHAN-TX
4MD AD-1C-xx.x AD-4C-xx.x	CHAN-RX	CHAN-TX
40-SMR1-C 40-SMR2-C	ADD-RX	DROP-TX
15216-MD-40-ODD 15216-MD-40-EVEN	CHAN-RX	CHAN-TX
15216-EF-40-ODD 15216-EF-40-EVEN	CHAN-RX	CHAN-TX
15216-MD-48-ODD 15216-MD-48-EVEN	CHAN-RX	CHAN-TX



Note

When the 40-SMR1-C or 40-SMR2-C card operates along with the 15216-MD-40-ODD, 15216-EF-40-ODD, or 15216-MD-48-ODD (ONS 15216 40 or 48-channel mux/demux), the OCH ports on the patch panel are the endpoints of the OCHNC circuit.

When the 40-SMR1-C or 40-SMR2-C card operates along with the 40-MUX-C and 40-DMX-C cards, the endpoints of the OCHNC circuit are on the MUX/DMX cards.

13.1.2 OCHCC Circuits

OCHCC circuits extend the OCHNC to create an optical connection from the source client port to the destination client port of the TXP/MXP cards. An OCHCC circuit represents the actual end-to-end client service passing through the DWDM system.

Each OCHCC circuit is associated to a pair of client or trunk ports on the transponder (TXP), muxponder (MXP), GE_XP (in layer-1 DWDM mode), 10GE_XP (in layer-1 DWDM mode), or ITU-T line card.

The OCHCCs can manage splitter protection as a single protected circuit. However, for the Y-Cable protection, two OCHCC circuits and two protection groups are required.

13.1.3 OCH Trail Circuits

OCH trail circuits transport the OCHCCs. The OCH trail circuit creates an optical connection from the source trunk port to the destination trunk port of the Transponder (TXP), Muxponder (MXP), GE_XP, 10GE_XP, or ITU-T line card. The OCH trail represents the common connection between the two cards, over which all the client OCHCC circuits, SVLAN circuits or STS circuits are carried.

Once an OCHCC is created, a corresponding OCH Trail is automatically created. If the OCHCC is created between two TXP, MXP, GE_XP, or 10GE_XP cards, two circuits are created in the CTC. These are:

One OCHCC (at client port endpoints)

One OCH trail (at trunk port endpoints)

If the OCHCC is created between two TXPP or two MXPP cards, three circuits are created in the CTC. These are:

- One OCHCC (at client port endpoints)
- Two OCH Trails (at trunk port endpoints)
 - One for the working and other for the protect trunk.



Note

On a TXP, MXP, and GE_XP card (in layer 1 DWDM mode), additional OCHCC circuits are created over the same OCH trail.



Note

On a TXP, MXP, GE_XP (in layer 1 DWDM mode), and 10GE_XP (in layer 1 DWDM mode) card, the OCH trail cannot be created independently, and is created along with the first OCHCC creation on the card. However, on a GE_XP card (in layer-2 DWDM mode), 10GE_XP card (in layer-2 DWDM mode), and ADM_10G card, an OCH trail can be created between the trunk ports for the upper layer circuits (SVLAN in GE_XP/10GE_XP and STS in ADM_10G). No OCHCC is supported in these cases.

If the OCHCC is created between two ITU-T line cards, only one trunk port belongs to the OCHCC at each end of the circuit. [Table 13-2](#) lists the ports that can be OCHCC and OCH trail endpoints.

Table 13-2 OCHCC and OCH Trail Ports

Card	OCHCC	OCH Trail
TXPs	Any client port	Any trunk port
MXPs		
GE_XP		
10GE_XP		
ADM-10G		
ITU-T line cards: <ul style="list-style-type: none"> • OC48/STM64 EH • OC192 SR/STM64 • MRC-12 • MRC-2.5-12 • MRC-2.5G-4 	Any trunk port	Any trunk port

Figure 13-2 shows the relationships and optical flow between the OCHCC, OCH trail, and OCHNC circuits.

Figure 13-2 Optical Channel Management

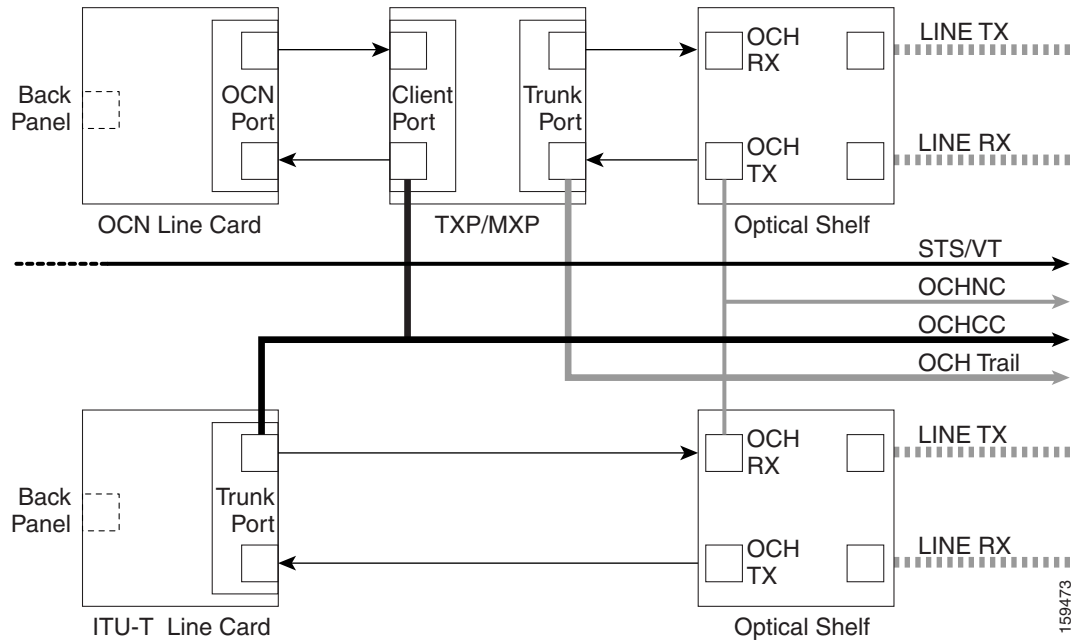

13.1.4 Administrative and Service States

OCHCCs, OCH trails, and OCHNCs occupy three different optical layers. Each OCH circuit has its own administrative and service states. The OCHCCs impose additional restrictions on changes that can be made to client card port administrative state.

The OCHCC service state is the sum of the OCHCC service state and the OCH trail service state. When creating an OCHCC circuit, you can specify an initial state for both the OCHCC and the OCH trail layers, including the source and destination port states. The ANSI/ETSI administrative states for the OCHCC circuits and connections are:

- IS/Unlocked
- IS,AINS/Unlocked,AutomaticInService
- OOS,DSBLD/Locked,disabled

OCHCC service states and source and destination port states can be changed independently. You can manually modify client card port states in all traffic conditions. Setting an OCHCC circuit to OOS,DSBLD/Locked,disabled state has no effect on OCHCC client card ports.

An OCH trail is created automatically when you create an OCHCC. OCH trails can be created independently between OCH-10G cards and GE_XP and 10GE_XP when they are provisioned in Layer 2 Over DWDM mode. The OCH trail ANSI/ETSI administrative states include:

- IS/Unlocked
- IS,AINS/Unlocked,automaticInService
- OOS,DSBLD/Locked,disabled

You can modify OCH trail circuit states from the Edit Circuit window. Placing an OCH trail OOS,DSBLD/Locked,disabled causes the following state changes:

- The state of the OCH trail ports changes to OOS,DSBLD/Locked,disabled.
- The OCHNC state changes to OOS,DSBLD/Locked,disabled.

Changing the OCH trail state to IS,AINS/Unlocked,automaticInService causes the following state changes:

- The state of the OCH trail trunk ports changes to IS/Unlocked.
- The OCHNC state changes to IS,AINS/Unlocked,automaticInService.

The OCH trail service state is the sum of the OCHCC trunk port state and the OCHNC (if applicable) state. Changing the client card trunk ports to OOS,DSBLD/Locked,disabled when the OCH trail state IS/Unlocked will cause the OCH trail state to change to OOS,DSBLD/Locked,disabled and its status to change to Partial.

The OCHNC circuit states are not linked to the OCHCC circuit states. The administrative states for the OCHNC circuit layer are:

- IS,AINS/Unlocked,AutomaticInService
- OOS,DSBLD/Locked,disabled

When you create an OCHNC, you can set the target OCHNC circuit state to IS/Unlocked or OOS,DSBLD/Locked,disabled. You can create an OCHNC even if OCHNC source and destination ports are OOS,MT/Locked,maintenance. The OCHNC circuit state will remain OOS-AU,AINS/Unlocked-disabled,automaticInService until the port maintenance state is removed. During maintenance or laser shutdown, the following behavior occurs:

- If OCHNCs or their end ports move into an AINS/AutomaticInService state because of user maintenance activity on an OCHCC circuit (for example, you change an optical transport section (OTS) port to OOS,DSBLD/Locked,disabled), Cisco Transport Controller (CTC) suppresses the loss of service (LOS) alarms on the TXP, MXP, GE_XP, 10GE_XP, or ITU-T line card trunk ports and raises a Trail Signal Fail condition. Line card trunk port alarms are not changed, however.
- If TXP client or trunk port are set to OOS,DSBLD/Locked,disabled state (for example, a laser is turned off) and the OCH trunk and OCH filter ports are located in the same node, the OCH filter LOS alarm is demoted by a Trail Signal Fail condition.

OCHCCs are associated with the client card end ports. Therefore, the following port parameters cannot be changed when they carry an OCHCC:

- Wavelength
- Service (or payload type)
- Splitter protection
- ITU-T G.709
- Forward error correction (FEC)
- Mapping

Certain OCHCC parameters, such as service type, service size, and OCHNC wavelength can only be modified by deleting and recreating the OCHCC. If the OCHCC has MXP end ports, you can modify services and parameters on client ports that are not allocated to the OCHCC. Some client port parameters, such as Ethernet frame size and distance extension, are not part of an OCHCC so they can be modified if not restricted by the port state. For addition information about administrative and service states, see [Appendix B, “Administrative and Service States.”](#)

13.1.5 Creating and Deleting OCHCCs

To create an OCHCC, you must know the client port states and their parameters. If the client port state is IS/Unlocked, OCHCC creation will fail if the OTN line parameters (ITU-T G.709, FEC, signal fail bit error rate (SF BER), and signal degrade bit error rate (SD BER) on the OCHCC differ from what is provisioned on the trunk port. The port state must be changed to OOS-DSL/Locked,disabled in order to complete the OCHCC.

If you delete an OCHCC, you can specify the administrative state to apply to the client card ports. For example, you can have the ports placed in OOS,DSBLD/Locked,disabled state after an OCHCC is deleted. If you delete an OCHCC that originates and terminates on MXP cards, the MXP trunk port states can only be changed if the trunk ports do not carry other OCHCCs.

13.1.6 OCHCCs and Service and Communications Channels

Although optical service channels (OSCs), generic communications channels (GCCs), and data communications channels (DCCs) are not managed by OCHCCs, the following restrictions must be considered when creating or deleting OCHCCs on ports with service or communication channels:

- Creating an OCHCC when the port has a service or a communications channel is present—OCHCC creation will fail if the OCHCC parameters are incompatible with the GCC/DCC/GCC. For example, you cannot disable ITU-T G.709 on the OCHCC if a GCC carried by the port requires the parameter to be enabled.

- Creating a service or communications channel on ports with OCHCCs—OCHCC creation will fail if the GCC/DCC/GCC parameters are incompatible with the OCHCC.
- Deleting an OCHCC on ports with service or communications channels—If an OSC/GCC/DCC is present on a TXP, MXP, GE_XP, 20GE_XP, or ITU-T line card client or trunk port, you cannot set these ports to the OOS,DSBLD/Locked,disabled state after the OCHCC circuit is deleted.

13.2 Virtual Patchcords

The TXP, MXP, TXPP, MXPP, GE_XP, 10GE_XP, and ADM-10G client ports and DWDM filter ports can be located in different nodes or in the same single-shelf or multishelf node. ITU-T line card trunk ports and the corresponding DWDM filter ports are usually located in different nodes.

OCHCC provisioning requires a virtual patchcord between the client card trunk ports and the DWDM filter ports. Depending on the physical layout, this can be an internal patchcord or a provisionable (external) patchcord (PPC). Both patchcord types are bidirectional. However, each direction is managed as a separate patchcord.

Internal patchcords provide virtual links between the two sides of a DWDM shelf, either in single-shelf or multishelf mode. They are viewed and managed in the Provisioning > WDM-ANS > Internal Patchcords tab.

When the NE update file is imported in CTC, the Provisioning > WDM-ANS > Internal Patchcord tab is populated with the internal patchcords. When you create an internal patchcord manually, the Internal Patchcord Creation wizard prompts you to choose one of the following internal patchcord types:

- Trunk to Trunk (L2)—Creates an internal patchcord between two trunk ports (in NNI mode) of a GE_XP, 10GE_XP, GE_XPE, or 10GE_XPE card provisioned in the L2-over-DWDM mode.
- OCH-Trunk to OCH-Filter—Creates an internal patchcord between the trunk port of a TXP, MXP, GE_XP, 10GE_XP, or ITU-T line card, and an OCH filter card (wavelength selective switch, multiplexer, or demultiplexer).
- OCH-Filter to OCH-Filter—Creates an internal patchcord between a MUX input port and a DMX output port.
- OTS to OTS—Creates an internal patchcord between two OTS ports.
- Optical Path—Creates an internal patchcord between two optical cards, or between an optical card and a passive card.



Note

If a Side-to-Side PPC is created between nodes, it will no longer function if the node Security Mode mode is enabled (see the “DLP-G264 Enable Node Security Mode” task in the *Cisco ONS 15454 DWDM Procedure Guide*). When the Secure mode is enabled, it is no longer possible for the DCN extension feature to use the LAN interface to extend the internal network (due to the network isolation in this configuration mode). The result is that the topology discovery on the Side-to-Side PPC no longer operates.

Table 13-3 shows the internal patchcord Trunk (L2), OCH trunk, OCH filter, and OTS/OCH ports.

Table 13-3 Internal Patchcord Ports

Card	Trunk (L2) Port	OCH Trunk Ports	OCH Filter Ports	OTS/OCH Ports
GE_XP 10GE_XP GE_XPE 10GE_XPE	Trunk port in NNI mode	Any trunk port	—	—
TXPs MXPs ADM-10G ITU-T line cards	—	Any trunk port	—	—
OPT-BST OPT-BST-E OPT-BST-L	—	—	—	COM-TX COM-RX OSC-TX OSC-RX
OPT-AMP-17-C OPT-AMP-L	—	—	—	COM-TX COM-RX OSC-TX ¹ OSC-RX ¹ DC-TX ¹ DC-RX ¹
OPT-PRE	—	—	—	COM-TX COM-RX DC-TX DC-RX
OSCM OSC-CSM	—	—	—	COM-TX COM-RX OSC-TX OSC-RX
32MUX 32MUX-O 40-MUX-C	—	—	Any CHAN RX port	COM-TX
32DMX 32DMX-L 32DMX-O 40-DMX-C 40-DMX-CE	—	—	Any CHAN TX port	COM-RX

Table 13-3 Internal Patchcord Ports (continued)

Card	Trunk (L2) Port	OCH Trunk Ports	OCH Filter Ports	OTS/OCH Ports
32WSS 32WSS-L 40-WSS-C 40-WSS-CE	—	—	Any ADD port	COM-TX COM-RX EXP-TX EXP-RX DROP-TX
40-WXC-C	—	—	—	ADD-RX DROP-TX COM TX COM RX
80-WXC-C	—	—	—	EAD $i, i=1$ to 8 AD COM COM-RX DROP-TX EXP-TX
MMU	—	—	—	EXP A TX EXP A RX
40-SMR2-C	—	—	—	ADD-RX DROP-RX EXP-TX EXPi-RX
40-SMR1-C	—	—	—	ADD-RX DROP-RX EXP-TX EXP-RX LINE-RX LINE-TX
TDC-CC TDC-FC	—	—	—	DC-RX DC-TX
XT-40G XM-40G	—	Any trunk port	—	—
PASSIVE-MD-40-ODD PASSIVE-MD-40-EVEN	—	—	Any CHAN TX port	COM-RX COM-TX
PASSIVE-MD-ID-50 PASSIVE-15216-ID-50	—	—	—	COM-RX COM-TX

Table 13-3 Internal Patchcord Ports (continued)

Card	Trunk (L2) Port	OCH Trunk Ports	OCH Filter Ports	OTS/OCH Ports
PASSIVE-PP-4-SMR	—	—	—	EXP-RX
PASSIVE-PP-MESH-4				EXP-TX
PASSIVE-PP-MESH-8				
PASSIVE_DCU	—	—	—	DC-RX DC-TX

1. When provisioned in OPT-PRE mode.

PPCs are created and managed from the network view Provisioning > Provisionable Patchcord (PPC) tab (Figure 13-3), or from the node view (single-shelf mode) or multishelf view (multishelf mode) Provisioning > Comm Channel > PPC tab.

Figure 13-3 Network View Provisionable Patchcords Tab

Origination ID	Origination Node	Origination Shelf/Slot/Port/Side	Termination ID	Termination Node	Termination Shelf/Slot/Port/Side
1	tcc26	slot 3 (MMU), port 6, side C	1	tcc24	shelf 3, slot 3 (40 WXC), port 12, side C
2	tcc30	shelf 1, slot 5 (40 DMX C), port 3, side A	2	tcc22	shelf 1, slot 6 (40 MLX), port 3, side A
3	tcc24	shelf 3, slot 3 (40 WXC), port 13, side C	3	tcc26	slot 3 (MMU), port 5, side C
4	tcc26	slot 15 (MMU), port 6, side D	4	tcc24	shelf 3, slot 14 (40 WXC), port 12, side D
5	tcc22	slot 14 (ADM_10G), port 19 (Trunk)	5	tcc30	shelf 2, slot 6 (40 MLX), port 4, side B
6	tcc30	shelf 2, slot 5 (40 DMX C), port 4, side B	6	tcc22	slot 14 (ADM_10G), port 19 (Trunk)
7	tcc24	shelf 3, slot 14 (40 WXC), port 13, side D	7	tcc26	slot 15 (MMU), port 5, side D

PPCs are required when the TXP, MXP, GE_XP, 10GE_XP, ADM-10G, or ITU-T line card is installed in a different node than the OCH filter ports. They can also be used to create OTS-to-OTS links between shelves that do not have OSC connectivity. PPCs are routable and can be used to discover network topologies using Open Shortest Path First (OSPF). GCCs and DCCs are not required for PPC creation. When you create a PPC, the PPC Creation wizard asks you to choose one of the following PPC types:

- Client/Trunk to Client/Trunk (L2)—Creates a PPC between two client or trunk ports (in NNI mode) on GE_XP, 10GE_XP, GE_XPE, or 10GE_XPE cards provisioned in the L2-over-DWDM mode.
- Client/Trunk to Client/Trunk—Creates a PPC between two client or trunk ports on TXP, MXP, GE_XP, 10GE_XP, ADM_10G, or ITU-T line cards.
- Side to Side (OTS)—Creates a PPC between two OTS ports that belong to a Side. This option establishes data communications network (DCN) connectivity between nodes that do not have OSCM or OSC-CSM cards installed and therefore do not have OSC connectivity. CTC selects the OTS ports after you choose the origination and termination sides.
- OCH Trunk to OCH Filter—Creates a PPC between a OCH trunk port on a TXP, MXP, GE_XP, 10GE_XP, ADM-10G, or ITU-T line card and an OCH filter port on a multiplexer, demultiplexer, or wavelength selective switch card.

Table 13-4 shows the PPC Client/Trunk (L2), Client/Trunk, OTS, and OCH Filter ports.

Table 13-4 Provisionable Patchcord Ports

Card	Client/Trunk (L2) Port	Client/Trunk Port	OTS Port	OCH Filter Port
GE_XP 10GE_XP GE_XPE 10GE_XPE	Client or trunk port in NNI mode	Any trunk port	—	—
TXPs MXPs ADM-10G ITU-T line cards	—	Any trunk port	—	—
OPT-BST OPT-BST-E OPT-BST-L	—	—	COM RX ¹ LINE RX LINE TX	—
OPT-AMP-17-C OPT-AMP-L	—	—	COM RX ² COM TX ³ LINE RX ³ LINE TX ³	—
OPT-PRE	—	—	COM RX ⁴ COM TX ⁴	—
OSC-CSM	—	—	COM RX ¹ LINE RX LINE TX	—
32MUX 32MUX-O 40-MUX-C	—	—	—	Any CHAN RX port

Table 13-4 Provisionable Patchcord Ports (continued)

Card	Client/Trunk (L2) Port	Client/Trunk Port	OTS Port	OCH Filter Port
32DMX 32DMX-L 32DMX-O 40-DMX-C 40-DMX-CE	—	—	—	Any CHAN TX port
32WSS 32WSS-L 40-WSS-C 40-WSS-CE	—	—	—	Any ADD port
40-WXC-C	—	—	COM RX COM TX	—
80-WXC-C	—	—	EAD $i, i=1$ to 8 AD COM COM-RX DROP-TX EXP-TX	—
40-SMR1-C 40-SMR2-C	—	—	LINE RX LINE TX	—
MMU	—	—	EXP A RX EXP A TX	—

1. Line nodes only.
2. When card mode is OPT-PRE.
3. When card mode is OPT-LINE.
4. Line nodes with two OPT-PRE cards and no BST cards installed.

13.2.1 PPC Provisioning Rules

For Client/Trunk to Client/Trunk (L2) PPCs, the following provisioning rules and conditions apply:

- The card must be provisioned in the L2-over-DWDM mode.
- The client or trunk ports must be in the NNI mode.
- PPCs can be created only between NNI ports of the same size (1GE-1GE or 10GE-10GE).

For Client/Trunk to Client/Trunk PPCs, the following provisioning rules and conditions apply:

- Patchcords can be created on preprovisioned or physically installed cards.
- Trunk-to-trunk connections require compatible wavelengths if the port is equipped. A check is automatically performed during patchcord provisioning to ensure wavelength compatibility of ports.

- For connections involving one or more preprovisioned ports, no compatibility check is performed. For OCH Trunk to OCH Filter PPCs, the following provisioning rules and conditions apply:
 - GCC and DCC links are not required to create a PPC.
 - PPCs can be created for preprovisioned or physically installed cards.
 - OCH trunk and OCH filter ports must be on the same wavelength. CTC checks the ports for wavelength compatibility automatically during PPC provisioning.
 - For OC-48/STM-16 and OC-192/STM-64 ITU-T line cards, the wavelength compatibility check is performed only when the cards are installed. The check is not performed for preprovisioned cards.
 - For all other preprovisioned cards, a wavelength compatibility check is not performed if card is set to first tunable wavelength. The wavelength is automatically provisioned on the port, according to the add/drop port that you chose when you created the PPC.

13.3 End-to-End SVLAN Circuit

An end-to-end SVLAN circuit can be created between GE_XP, 10GE_XP, GE_XPE, or 10GE_XPE cards through a wizard in CTC. SVLAN circuits created this way are only a snapshot of the SVLAN settings (NNI and QinQ) of each card in the network. If an end-to-end SVLAN circuit is created via CTC and the SVLAN settings of the cards are changed manually, CTC does not update the SVLAN circuit created with the new settings. To update the SVLAN circuit in CTC, the circuit must be refreshed.

However, any changes made to subtended OCH trail circuits are reflected in the SVLAN circuit in CTC. If an OCH trail becomes incomplete and the current SVLAN circuit snapshot has some SVLAN circuits that are using it, they remain incomplete. If the snapshot contains incomplete SVLAN circuits and an OCH trail circuit becomes available, the incomplete SVLAN circuit snapshot in CTC appears to be complete.

When the destination port of the SVLAN circuit facing the router is configured as a NNI client port, the outgoing ethernet packets do not drop the SVLAN tag when they exit the MSTP network allowing the router to determine the origin of the ethernet packet.

SVLAN circuits are stateless circuits; an administrative or service state need not be set.



Note

During SVLAN provisioning, if a SVLAN circuit span using UNI ports in transparent mode is over subscribed, a warning message is displayed. However, the circuit is created. This is supported on channel groups on GE_XP, 10GE_XP, GE_XPE, or 10GE_XPE cards.

13.3.1 End-to-End SVLAN Provisioning Rules

The following provisioning rules and conditions apply to end-to-end SVLAN circuits:

- GE_XP, 10GE_XP, GE_XPE, and 10GE_XPE cards must be provisioned in L2-over-DWDM mode.
- SVLAN database must be loaded with the SVLAN.
- SVLAN circuits are routed through OCH trail circuits or PPC; Client/Trunk to Client/Trunk (L2). Therefore, before creating an SVLAN circuit, make sure that the subtended OCH trail circuits between GE_XP, 10GE_XP, GE_XPE, and 10GE_XPE cards or PPC links are created.
- For protected SVLAN circuits, create a ring (through OCH trail circuits), define a master node, and enable the protection role.

For information on how to create end-to-end SVLAN circuit, see the “NTP-G203 Create End to End SVLAN Circuits” procedure in the *Cisco ONS 15454 DWDM Procedure Guide*.