



# CHAPTER 19

## Performance Monitoring

---

Performance monitoring (PM) parameters are used by service providers to gather, store, set thresholds for, and report performance data for early detection of problems. In this chapter, PM parameters and concepts are defined for transponder, muxponder, and dense wavelength division multiplexing (DWDM) cards in the Cisco ONS 15454 including optical amplifier, multiplexer, demultiplexer, optical add/drop multiplexer (OADM), and optical service channel (OSC) cards.



**Note**

---

Unless otherwise specified, “ONS 15454” refers to both ANSI and ETSI shelf assemblies.

---

For information about enabling and viewing PM values, refer to the *Cisco ONS 15454 DWDM Procedure Guide*.

Chapter topics include:

- [19.1 Threshold Performance Monitoring, page 19-2](#)
- [19.2 Transponder, Muxponder, Xponder, and ADM-10G Card Performance Monitoring, page 19-2](#)
- [19.3 DWDM Card Performance Monitoring, page 19-17](#)
- [19.4 Optics and 8b10b PM Parameter Definitions, page 19-21](#)
- [19.5 ITU G.709 and ITU-T G.8021 Trunk-Side PM Parameter Definitions, page 19-22](#)
- [19.6 Full RMON Statistics PM Parameter Definitions, page 19-24](#)
- [19.7 FEC PM Parameter Definitions, page 19-27](#)
- [19.8 SONET PM Parameter Definitions, page 19-27](#)
- [19.9 SDH PM Parameter Definitions, page 19-28](#)
- [19.10 Pointer Justification Count Performance Monitoring, page 19-30](#)



**Note**

---

For additional information regarding PM parameters, refer to ITU G.826, ITU-T G.8021, ITU G.709, Telcordia documents GR-1230-CORE, GR-820-CORE, GR-499-CORE, and GR-253-CORE, and the ANSI T1.231 document entitled *Digital Hierarchy - Layer 1 In-Service Digital Transmission Performance Monitoring*.

---

## 19.1 Threshold Performance Monitoring

Thresholds are used to set error levels for each PM parameter. You can set individual PM threshold values from the Cisco Transport Controller (CTC) card view Provisioning tab. For procedures about provisioning card thresholds, such as line and path thresholds, refer to the *Cisco ONS 15454 DWDM Procedure Guide*.

During the accumulation cycle, if the current value of a PM parameter reaches or exceeds its corresponding threshold value, a threshold crossing alert (TCA) is generated by the node and is displayed by CTC. TCAs provide early detection of performance degradation. When a threshold is crossed, the node continues to count the errors during a given accumulation period. If zero is entered as the threshold value, generation of TCAs is disabled but performance monitoring continues.



### Note

Due to memory limitations and the number of TCAs generated by different platforms, you can manually add or modify the following two properties to the platform property file (CTC.INI for Windows and .ctrc for UNIX) to fit the need:

- **ctc.15xxx.node.tr.lowater=yyy** (where xxx is platform and yyy is the number of the lowater mark. The default lowater mark is 25.)
- **ctc.15xxx.node.tr.hiwater=yyy** (where xxx is platform and yyy is the number of the hiwater mark. The default hiwater mark is 50.)

If the number of the incoming TCA is greater than the hiwater mark, the node will keep the latest lowater mark and discard older ones.

Change the threshold if the default value does not satisfy your error monitoring needs. For example, customers with a critical OC192/STM64 transponder installed for 911 calls must guarantee the best quality of service on the line; therefore, they lower all thresholds on the client side so that the slightest error raises a TCA.



### Note

When LOS, LOS-P, or LOF alarms occur on TXP and MXP trunks, ITU-T G.709/SONET/SDH TCAs are suppressed. For details, see [Chapter 18, “Alarm and TCA Monitoring and Management.”](#)

## 19.2 Transponder, Muxponder, Xponder, and ADM-10G Card Performance Monitoring

This section lists PM parameters for transponder cards (TXP\_MR\_10G, TXP\_MR\_2.5G, TXPP\_MR\_2.5G, TXP\_MR\_10E, TXP\_MR\_10E\_C, and TXP\_MR\_10E\_L), muxponder cards (MXP\_2.5G\_10G, MXP\_2.5G\_10E, MXP\_2.5G\_10E\_C, MXP\_2.5G\_10E\_L, MXP\_MR\_2.5G, MXPP\_MR\_2.5G, MXP\_MR\_10DME-C, and MXP\_MR\_10DME-L), Xponder cards (GE\_XP, 10GE\_XP, GE\_XPE, 10GE\_XPE, OTU2\_XP), and ADM-10G card. The transponder, muxponder, Xponder, and ADM-10G PM parameters are divided into Optics PM, Payload PM, and OTN PM tabs. The tabs displayed vary depending on the card installed. For more information, see the “[19.2.1 Optics PM Window](#)” section on page 19-4, the “[19.2.2 Payload PM Window](#)” section on page 19-5, or the “[19.2.3 OTN PM Window](#)” section on page 19-11.



**Note**

For the OTU2\_XP card, if the PPM is not deleted properly from the CTC (but physically removed), the PMs continue to increase (even if the PPM is not present). To ensure the PMs do not increase when the PPM is not present, change the Service State of the PPM port to OOS (ANSI) or locked (ETSI) and move it back to IS (ANSI) or Unlocked (ETSI) state.

For ONS 15454 ANSI nodes, [Figure 19-1](#) shows where overhead bytes detected on the application-specific integrated circuits (ASICs) produce PM parameters for the TXP\_MR\_10G card. The remaining transponder, muxponder, Xponder, and ADM-10G cards perform similarly to this illustration.

**Figure 19-1 ONS 15454 ANSI Node PM Read Points for TXP\_MR\_10G Card**

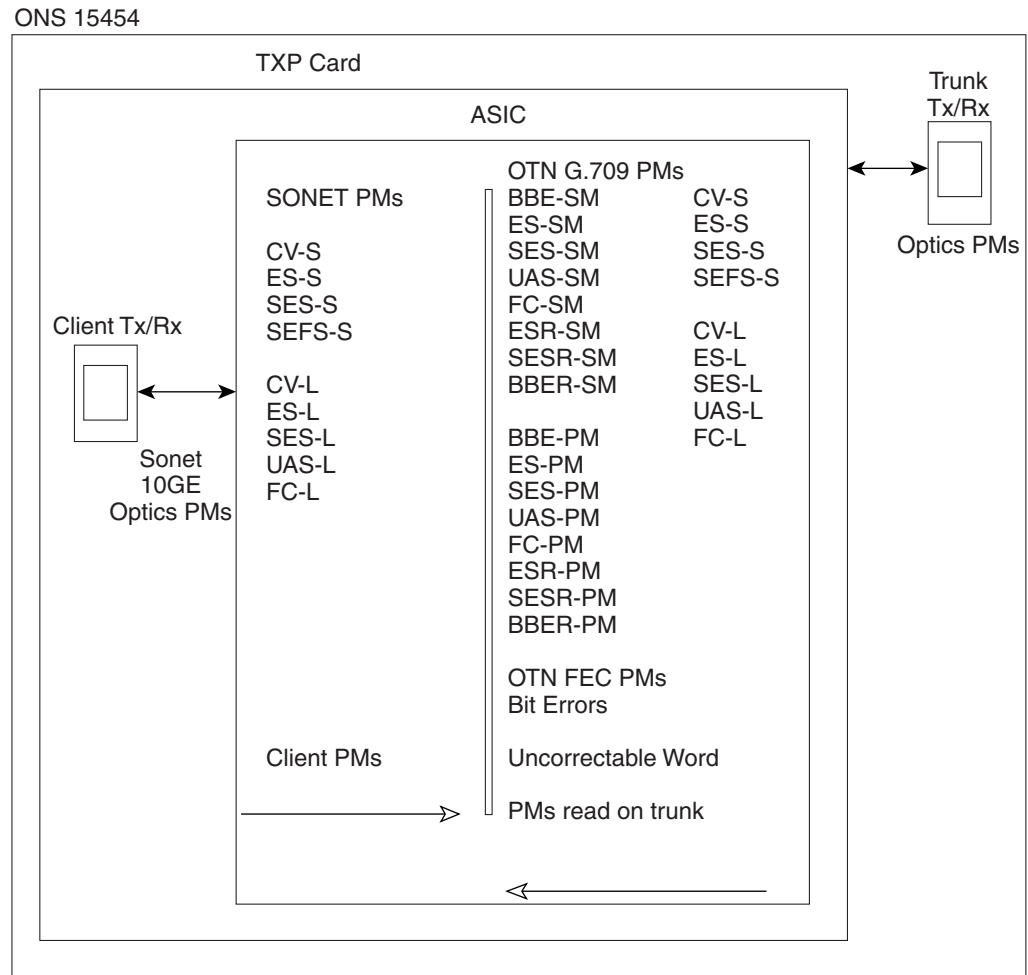

For ONS 15454 ETSI nodes, [Figure 19-2](#) shows where overhead bytes detected on the ASICs produce PM parameters for the TXP\_MR\_10G card. The remaining transponder, muxponder, Xponder, and ADM-10G cards perform similarly to this illustration.

Figure 19-2 ONS 15454 ETSI Node PM Read Points on TXP\_MR\_10G Cards

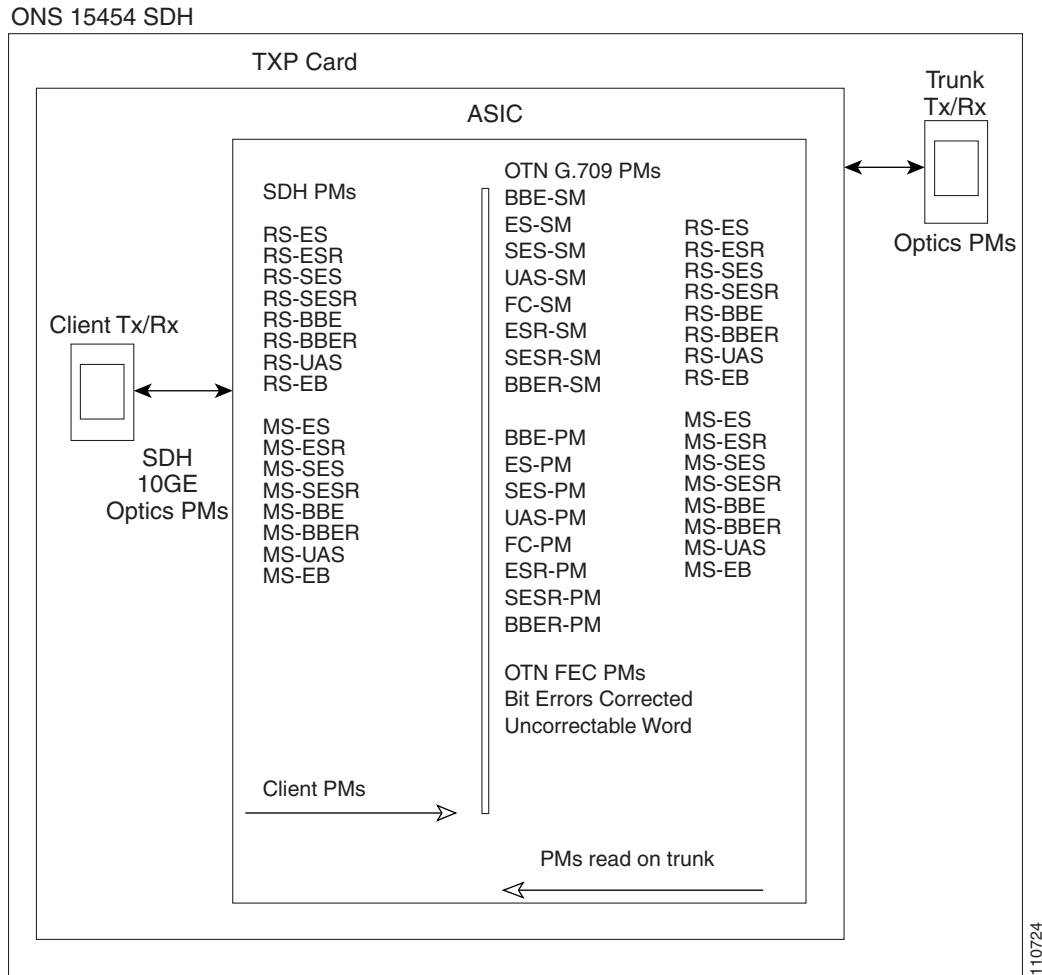

## 19.2.1 Optics PM Window

The Optics PM window lists parameters at the trunk and client side for all transponder, muxponder, Xponder (GE\_XP, 10GE\_XP, GE\_XPE, 10GE\_XPE, OTU2\_XP), and ADM-10G cards. The Optics PM window provides buttons to change the statistical values shown. The Refresh button manually refreshes statistics. Auto-Refresh sets a time interval at which automatic refresh occurs. In the Historical PM subtab, the Clear button sets the values on the card to zero. All counters on the card are cleared. The Help button activates context sensitive help. Table 19-1 lists the trunk-side and client-side optics PM parameters.

**Table 19-1 Trunk-Side and Client-Side Optics PM Parameters**

Trunk-Side/Client-Side Optics PM Parameters	Definition
Laser Bias (Avg,%)	Average Laser Bias Current (Laser Bias Avg) is the average percentage of laser bias current during the PM time interval.
Laser Bias (Max,%)	Maximum Laser Bias Current (Laser Bias Max) is the maximum percentage of laser bias current during the PM time interval.
Laser Bias (Min,%)	Minimum Laser Bias Current (Laser Bias Min) is the minimum percentage of laser bias current during the PM time interval.
Link Status	Indicates if the Fibre Channel link is receiving a valid Fibre Channel signal (carrier) from the attached Fibre Channel device. Up means present, and down means not present.
Rx Optical Pwr (Min,dBm)	Minimum Receive Optical Power (Rx Optical Pwr Min, dBm) is the minimum received optical power during the PM time interval.
Rx Optical Pwr (Avg,dBm)	Average Receive Optical Power (Rx Optical Pwr Avg, dBm) is the average received optical power during the PM time interval.
Rx Optical Pwr (Max,dBm)	Maximum Receive Optical Power (Rx Optical Pwr Max, dBm) is the maximum received optical power during the PM time interval.
Tx Optical Pwr (Min,dBm) <sup>1</sup>	Minimum Transmit Optical Power (Tx Optical Pwr Min, dBm) is the minimum optical power transmitted during the PM time interval.
Tx Optical Pwr (Avg,dBm) <sup>1</sup>	Average Transmit Optical Power (Tx Optical Pwr Avg, dBm) is the average optical power transmitted during the PM time interval.
Tx Optical Pwr (Max,dBm) <sup>1</sup>	Maximum Transmit Optical Power (Tx Optical Pwr Max, dBm) is the maximum optical power transmitted during the PM time interval.

1. On the trunk side, this PM is not available for the following cards: TXP\_MR\_2.5G, TXPP\_MR\_2.5G, MXP\_MR\_2.5G, and MXPP\_MR\_2.5G.

## 19.2.2 Payload PM Window

The Payload PM window subtabs change depending on the card provisioning. For more information about provisioning TXP, MXP, and Xponder cards, refer to the “Provision Transponder and Muxponder Cards” chapter in the *Cisco ONS 15454 DWDM Procedure Guide*. Possible Payload PM subtabs are: SONET, SDH, Statistics, Utilization, and History. The following buttons function the same on all of the tabs. Not all tabs have all of these buttons.

- The Refresh button manually refreshes statistics.
- Auto-Refresh sets a time interval at which automatic refresh occurs.
- The Baseline button resets the displayed statistics values to zero.
- (Statistics window only) The Clear button allows you to set the values to zero for displayed statistics, all statistics for a port, and all statistics for all optical ports on a card.

- The Help button activates context sensitive help.

For a list of the payload PM provisioning options for all transponder, muxponder, and Xponder cards, refer to the *Cisco ONS 15454 DWDM Procedure Guide*. The options selected in the Provisioning tab can affect the parameters displayed in the Performance > Payload PM tab.

Table 19-2 lists the PM parameter types that appear when a particular port type is provisioned for a transponder or muxponder card.

**Table 19-2 Transponder, Muxponder, and Xponder Port Type PM Provisioning Options**

If this Port Type is Provisioned <sup>1</sup>	The Following PM Types are Activated <sup>2</sup>
SONET/SDH (including 10G Ethernet WAN Phy) OC3/STM1 OC12/STM4 OC48/STM16	SONET or SDH PMs
10G Ethernet LAN Phy 10G FiberChannel ONE_GE FC1G FC2G FC1G ISL FC2G ISL FICON1G FICON2G FICON1G ISL FICON2G ISL ISC COMPAT ISC PEER	Full remote monitoring (RMON) statistics
ESCON DV6000 SDI_D1_VIDEO HDTV PASS_THRU ETR_CLO	Payload PMs are not applicable to 2R port types.

1. The port type is provisioned from card view on the Provisioning > Pluggable Port Modules tab. For pluggable port module (PPM) provisioning procedures, refer to the *Cisco ONS 15454 DWDM Procedure Guide*.
2. Performance monitoring parameters are displayed from the card view on the Performance tab.

### 19.2.2.1 Payload PM SONET/SDH Window

Table 19-3 lists SONET/SDH layer near-end and far-end PM parameters listed in the card view on the Performance > Payload PM > SONET or SDH tab. SONET/SDH layer PMs are available when the client type is set to OC3/STM1, OC12/STM4, or OC48/STM16 on the TXP\_MR\_2.5G or when OC192/STM64 is set on the TXP\_MR\_10G, TXP\_MR\_10E, TXP\_MR\_10E\_C, TXP\_MR\_10E\_L, ADM-10G, or OTU2\_XP card on ONS 15454 SONET nodes or ONS 15454 SDH nodes. OC48/STM16 trunk PMs are available on MXP\_MR\_2.5G and MXPP\_MR\_2.5G cards on ONS 15454 SONET or ONS 15454 SDH nodes. OC48/STM16 client PMs are available on MXP\_2.5G\_10G, MXP\_2.5G\_10E, MXP\_2.5G\_10E\_C, and MXP\_2.5G\_10E\_L cards on ONS 15454 SONET or ONS 15454 SDH nodes. For PM definitions, see Table 19-30 on page 19-27 and Table 19-31 on page 19-29.

**Table 19-3** ONS 15454 SONET/SDH Layer Far-End and Near-End PMs

	Layer Far-End (FE) <sup>1, 2</sup>	Layer Near-End <sup>1, 2</sup>	Note
SONET	CV-LFE ES-LFE FC-LFE SES-LFE UAS-LFE	CV-L CV-S ES-L ES-S FC-L SES-L SES-S SEF-S UAS-L	Applicable standard is Telcordia GR-253.
SDH	MS-BBE MS-BBER MS-EB MS-ES MS-ESR MS-SES MS-SESR MS-UAS	RS-BBE RS-BBER RS-EB RS-ES RS-ESR RS-SES RS-SESR RS-UAS MS-BBE MS-BBER MS-EB MS-ES MS-ESR MS-SES MS-SESR MS-UAS	Applicable standard is Telcordia GR-253.

1. Applicable to optical channel (OCH) and Client (CLNT) facilities.
2. For MXP\_MR\_2.5G and MXPP\_MR\_2.5G cards, these parameters are shown in the Performance > Payload PM > SONET PM tabs in the card view.

### 19.2.2.2 Payload PM Statistics Window

Table 19-4 lists the 10 Gigabit Ethernet (10 GE) payload statistics that are available on the TXP\_MR\_10G, TXP\_MR\_10E, TXP\_MR\_10E\_C, TXP\_MR\_10E\_L, ADM-10G, and OTU2\_XP cards. PPM provisioning must be completed under the card view Provisioning > Pluggable Port Modules tab for 10 GE to be enabled. For PPM provisioning procedures, refer to the *Cisco ONS 15454 DWDM Procedure Guide*. The parameters are listed under card view on the Performance > Payload PM > Statistics tab. For 10 GE payload definitions, see Table 19-28 on page 19-24.

**Note**

Utilization PMs are also available per port.

**Table 19-4** Full RMON Statistics on TXP\_MR\_10G, TXP\_MR\_10E, TXP\_MR\_10E\_C, TXP\_MR\_10E\_L, GE\_XP, 10GE\_XP, GE\_XPE, 10GE\_XPE, ADM-10G, and OTU2\_XP Cards

Full RMON Statistics	
dot3StatsFCSErrors	etherStatsBroadcastPkts
dot3StatsFrameTooLong	etherStatsCRCAlignErrors
ifInBroadcastPkts	etherStatsFragments
ifInErrors	etherStatsJabbers
ifInErrorsBytePkts	etherStatsMulticastPkts
ifInFramingErrorPkts	etherStatsOctets
ifInJunkInterPkts	etherStatsOversizePkts
ifInMulticastPkts	etherStatsPkts64Octets
ifInOctets	etherStatsPkts65to127Octets
ifOutBroadcastPkts	etherStatsPkts128to255Octets
ifOutMulticastPkts	etherStatsPkts256to511Octets
ifOutOctets	etherStatsPkts512to1023Octets
rxTotalPkts	etherStatsPkts1024to1518Octets
Time Last Cleared	etherStatsUndersizePkts
txTotalPkts	rxControlFrames
	rxPauseFrames
	rxUnknownOpcodeFrames

Table 19-5 lists the payload PM parameters that are available on the TXP\_MR\_2.5G and the TXPP\_MR\_2.5G cards when the ONE\_GE or FC1G client type is enabled. For PPM provisioning procedures, refer to the *Cisco ONS 15454 DWDM Procedure Guide*. For payload definitions, see the “19.4 Optics and 8b10b PM Parameter Definitions” section on page 19-21 and the “19.6 Full RMON Statistics PM Parameter Definitions” section on page 19-24.



**Note**

Payload PM is not available for the 2FC client type.

**Table 19-5** Gigabit Ethernet (GE) or Fibre Channel (FC) Payload PMs for the TXP\_MR\_2.5G and TXPP\_MR\_2.5G Cards

GE or FC Payload Performance Parameters
8b/10bDataOrderedSets
8b/10bIdleOrderedSets
8b/10bNonIdleOrderedSets
8b/10bStatsEncodingDispErrors
ifInErrors
rxTotalPkts

Table 19-6 lists the payload PM parameters that are available on the OTU2\_XP card when the 10G FC client type is enabled. For PPM provisioning procedures, refer to the *Cisco ONS 15454 DWDM Procedure Guide*. For payload definitions, see the “19.4 Optics and 8b10b PM Parameter Definitions” section on page 19-21 and the “19.6 Full RMON Statistics PM Parameter Definitions” section on page 19-24.

**Table 19-6** 10G Fibre Channel (FC) Payload PMs for the OTU2\_XP Card**10G FC Payload Performance Parameters**

---

```

rxTotalPkts
mediaIndStatsRxFramesTruncated
mediaIndStatsRxFramesTooLong
mediaIndStatsRxFrameBadCRC
ifInOctets
ifInErros

```

---

Table 19-7 lists the payload PM parameters that are available on the MXP\_MR\_2.5G and the MXPP\_MR\_2.5G cards when the ONE\_GE or the FC1G client type is enabled. For PPM provisioning procedures, refer to the *Cisco ONS 15454 DWDM Procedure Guide*. For payload definitions, see the “19.4 Optics and 8b10b PM Parameter Definitions” section on page 19-21 and the “19.6 Full RMON Statistics PM Parameter Definitions” section on page 19-24.

**Table 19-7** ONE\_GE or FC1G Payload PMs for the MXP\_MR\_2.5G and MXPP\_MR\_2.5G Cards**ONE\_GE or FC1G Payload Performance Parameters**

---

```

8b10bInvalidOrderedSets
8b10bStatsEncodingDispErrors
ifInDiscards
ifInErrors
ifInOctets
ifOutDiscards
ifOutOctets
mediaIndStatsRxFramesBadCRC
mediaIndStatsRxFramesTooLong
mediaIndStatsRxFramesTruncated
mediaIndStatsTxFramesBadCRC
rxTotalPkts
txTotalPkts

```

---

Table 19-8 lists the FC client-side payload PM parameters. FC payload PMs are available on the FC port on both the MXP\_MR\_2.5G and the MXPP\_MR\_2.5G cards when the FC1G client type is enabled. For PPM provisioning procedures, refer to the *Cisco ONS 15454 DWDM Procedure Guide*. For payload definitions, see the “19.6 Full RMON Statistics PM Parameter Definitions” section on page 19-24.

**Table 19-8** FC1G Payload PMs on the Client Side**FC1G Payload PMs on the Client Port**

---

```

fcStatsLinkRecoveries
fcStatsRxCredits
fcStatsTxCredits
fcStatsZeroTxCredits
gfpStatsRoundTripLatencyUsec
gfpStatsRxDistanceExtBuffers
gfpStatsTxDistanceExtBuffers

```

---

Table 19-9 lists the Transparent Generic Framing Procedure (GFP-T) payload PMs. The GFP-T payload PMs are available on the GFP port on both the MXP\_MR\_2.5G and the MXPP\_MR\_2.5G cards when the ONE\_GE or the 1 FC client type is enabled. GFP-T payload PMs are also available on the client port on both the MXP\_MR\_2.5G and the MXPP\_MR\_2.5G cards when the 1 FC client type is enabled. For PPM provisioning procedures, refer to the *Cisco ONS 15454 DWDM Procedure Guide*. For payload definitions, see the “19.6 Full RMON Statistics PM Parameter Definitions” section on page 19-24.

**Table 19-9 GFP-T Payload PMs**

GFP-T Payload PMs on the GFP Port
gfpStatsCSFRaised
gfpStatsLFDRaised
gfpStatsRxCRCErrors
gfpStatsRxMBitErrors
gfpStatsRxSBitErrors
gfpStatsRxTypeInvalid

### 19.2.2.3 MXP\_MR\_2.5G/MXPP\_MR\_2.5G Payload Utilization Window

The Payload PM Utilization window in the card view Performance > Payload > Utilization tab shows the percentage of transmit (Tx) and receive (Rx) line bandwidth used by the ports during consecutive time segments. This tab cannot be viewed unless the appropriate PPM port type is provisioned. For PPM provisioning procedures, refer to the *Cisco ONS 15454 DWDM Procedure Guide*. The Utilization window provides an Interval list that enables you to set time intervals of 15 minutes or 1 day. Line utilization is calculated with the following formulas:

$$Rx = (\text{inOctets} + \text{inPkts} * 20) * 8 / 100\% \text{ interval} * \text{maxBaseRate}$$

$$Tx = (\text{outOctets} + \text{outPkts} * 20) * 8 / 100\% \text{ interval} * \text{maxBaseRate}$$

The interval is defined in seconds. The maxBaseRate is defined by raw bits per second in one direction for the port (that is, 1 Gbps). The maxBaseRate for MXP\_MR\_2.5G and MXPP\_MR\_2.5G cards is shown for the ONS 15454 nodes in Table 19-10.

**Table 19-10 maxBaseRate for STS and VC Circuits**

STS/VC	maxBaseRate
STS-1/VC3	51840000
STS-3c/VC4	155000000
STS-6c/VC4-2c	311000000
STS-12c/VC4-4c	622000000



**Note**

Line utilization numbers express the average of ingress and egress traffic as a percentage of capacity.

## 19.2.2.4 Payload History Window

The Payload PM History window in the card view Performance > Payload > History tab lists past statistics for the previous time intervals. This tab cannot be viewed unless the appropriate PPM port type is provisioned. For PPM provisioning procedures, refer to the *Cisco ONS 15454 DWDM Procedure Guide*. Depending on the selected time interval, the History window displays the statistics for each port for the number of previous time intervals as shown in [Table 19-11](#).

**Table 19-11 History Statistics per Time Interval**

Time Interval	Number of Intervals Displayed
15 minutes	32 (current and previous)
1 day (24 hours)	2 (current and previous)

## 19.2.3 OTN PM Window

The OTN tab has an ITU-T G.709 PM subtab and an FEC PM subtab. Both subtabs provide buttons to change the statistical values shown in the Performance tab. The Refresh button manually refreshes statistics. Auto-Refresh sets a time interval at which automatic refresh occurs. The Baseline button resets the displayed statistics values to zero. The Statistics window also has a Clear button. The Clear button sets the values on the card to zero. All counters on the card are cleared. The Help button activates context sensitive help. For more information about provisioning optical transport network (OTN) settings, refer to the *Cisco ONS 15454 DWDM Procedure Guide*.

[Table 19-12](#) lists the OTN PM provisioning options for all transponder, muxponder, Xponder (GE\_XP, 10GE\_XP, GE\_XPE, 10GE\_XPE), and ADM-10G cards. The options selected in the Provisioning tab affects the parameters displayed in the Performance > OTN PM tab.

**Table 19-12 Transponder, Muxponder, and Xponder PM Provisioning Options**

Card	OTN Provisioning <sup>1</sup>
MXPP_MR_2.5G	—
MXP_2.5G_10E	G.709 FEC FEC Thresholds
MXP_2.5G_10E_C	G.709 FEC FEC Thresholds
MXP_2.5G_10E_L	G.709 FEC FEC Thresholds
MXP_2.5G_10G	G.709 FEC FEC Thresholds
MXP_MR_2.5G	—
MXP_MR_10DME_C	G.709 FEC FEC Thresholds

**Table 19-12 Transponder, Muxponder, and Xponder PM Provisioning Options (continued)**

<b>Card</b>	<b>OTN Provisioning<sup>1</sup></b>
MXP_MR_10DME_L	G.709 FEC FEC Thresholds
TXPP_MR_2.5G	G.709 FEC FEC Thresholds
TXP_MR_10E	G.709 FEC FEC Thresholds
TXP_MR_10E_C	G.709 FEC FEC Thresholds
TXP_MR_10E_L	G.709 FEC FEC Thresholds
TXP_MR_10G	G.709 FEC FEC Thresholds
TXP_MR_2.5G	G.709 FEC FEC Thresholds
ADM-10G	G.709 FEC FEC Thresholds
GE_XP	G.709 FEC FEC Thresholds
10GE_XP	G.709 FEC FEC Thresholds
GE_XPE	G.709 FEC FEC Thresholds
10GE_XPE	G.709 FEC FEC Thresholds
OTU2_XP	G.709 FEC FEC Thresholds

1. OTN provisioning is performed from card view on the Provisioning > OTN > OTN Lines, G.709 Thresholds, and FEC Thresholds tabs.

Table 19-13 lists the OTN trunk-side PM parameters listed on the G.709 tab. OTN PMs are available when ITU G.709 is enabled from the card view Provisioning > OTN > OTN Lines tab. OTN PMs are not available on MXP\_MR\_2.5G and MXPP\_MR\_2.5G cards. For ITU G.709 section and path monitoring PM definitions, see the “19.5 ITU G.709 and ITU-T G.8021 Trunk-Side PM Parameter Definitions” section on page 19-22.

**Table 19-13 ITU G.709 OTN Trunk-Side PMs**

OTN Layer (Near End and Far End) <sup>1</sup>	Note
BBE-SM BBER-SM ES-SM ESR-SM FC-SM SES-SM SESR-SM UAS-SM FC-SM	ITU G.709 standard section monitoring ITU-T G.8021
BBE-PM BBER-PM ES-PM ESR-PM FC-PM SES-PM SESR-PM UAS-PM	ITU G.709 standard path monitoring ITU-T G.8021

1. Applicable to OCH facility.

Table 19-14 lists the forward error correction (FEC) PM parameters. FEC PMs are available when ITU-T G.709 is enabled and FEC is set to standard or enhanced. These parameters are provisioned from the card view Provisioning > OTN > OTN Lines tab. FEC PMs are not available on MXP\_MR\_2.5G and MXPP\_MR\_2.5G cards. For PM definitions, see the “19.7 FEC PM Parameter Definitions” section on page 19-27.

**Table 19-14 FEC OTN Trunk-Side PMs**

FEC Trunk-Side PMs	FEC (Near End) <sup>1</sup>
Bit Errors	BIT-EC
Uncorrectable Words	UNC-WORDS

1. Applicable to OCH facility.

Table 19-15 lists ONS 15454 optics and 8b10b PM parameters. For ONS 15454 optics and 8b10b definitions, see the “19.4 Optics and 8b10b PM Parameter Definitions” section on page 19-21.

**Table 19-15 ONS 15454 Optics and 8b10b PMs**

Optics (Near End) <sup>1</sup>	8B10B (Near End) <sup>2</sup>
LBCL-AVG	CGV
LBCL-MAX	DCG
LBCL-MIN	IOS
OPT-AVG	IPC
OPT-MAX	NIOS
OPT-MIN	VPC
OPR-AVG	
OPR-MAX	
OPR-MIN	

1. The TXP\_MR\_2.5G and TXPP\_MR\_2.5G card Enterprise System Connection (ESCON) payload does not support optics PMs on the client port due to Small Form-factor Pluggable (SFP)-imposed restrictions.
2. Applicable to TXP\_MR\_2.5G and TXPP\_MR\_2.5G cards only.

## 19.2.4 Ether Ports PM Window

CTC provides Ethernet port performance information, including line-level parameters, port bandwidth consumption, and historical Ethernet statistics. The Ethernet performance information is divided into the Statistics, Utilization, and History tabbed windows within the card view Performance tab window. For more information about provisioning ether ports, refer to the *Cisco ONS 15454 DWDM Procedure Guide*.

### 19.2.4.1 Ether Port Statistics Window

The Ethernet Statistics window lists Ethernet parameters at the line level. The Statistics window provides buttons to change the statistical values shown. The Baseline button resets the displayed statistics values to zero. The Refresh button manually refreshes statistics. Auto-Refresh sets a time interval at which automatic refresh occurs.

[Table 19-16](#) defines the Ethernet Port statistics parameters.

**Table 19-16 E-Series Ethernet Statistics Parameters**

Parameter	Definition
Time Last Cleared	A time stamp indicating the last time statistics were reset.
ifInOctets	Number of bytes received since the last counter reset.
rxTotalPkts	Number of received packets.
ifInUcastPkts	Number of unicast packets received since the last counter reset.
ifInMulticastPkts	Number of multicast packets received since the last counter reset.
ifInDiscards	The number of inbound packets that were chosen to be discarded even though no errors had been detected to prevent their being deliverable to a higher-layer protocol. One possible reason for discarding such a packet could be to free buffer space.
ifOutOctets	Number of bytes transmitted since the last counter reset.
txTotalPkts	Number of transmitted packets.

**Table 19-16 E-Series Ethernet Statistics Parameters (continued)**

Parameter	Definition
ifOutMulticastPkts	Number of multicast packets transmitted.
ifOutBroadcastPkts	Number of broadcast packets transmitted.
ifOutDiscards	Number of outbound packets which were chosen to be discarded even though no errors had been detected to prevent their transmission. A possible reason for discarding such packets could be to free up buffer space.
ifOurErrors	Number of outbound packets or transmission units that could not be transmitted because of errors.
dot3StatsAlignmentErrors	A count of frames received on a particular interface that are not an integral number of octets in length and do not pass the FCS check.
dot3StatsFCSErrors	A count of frames received on a particular interface that are an integral number of octets in length but do not pass the FCS check.
dot3StatsFrameTooLong	A count of frames received on a particular interface that exceed the maximum permitted frame size.
etherStatsUndersizePkts	The total number of packets received that were less than 64 octets long (excluding framing bits, but including FCS octets) and were otherwise well formed.
etherStatsFragments	The total number of packets received that were less than 64 octets in length (excluding framing bits but including FCS octets) and had either a bad FCS with an integral number of octets (FCS Error) or a bad FCS with a nonintegral number of octets (Alignment Error).  <b>Note</b> It is entirely normal for etherStatsFragments to increment. This is because it counts both runts (which are normal occurrences due to collisions) and noise hits.
etherStatsPkts64Octets	The total number of packets (including bad packets) received that were 64 octets in length (excluding framing bits but including FCS octets).
etherStatsPkts65to127Octets	The total number of packets (including bad packets) received that were between 65 and 127 octets in length inclusive (excluding framing bits but including FCS octets).
etherStatsPkts128to255Octets	The total number of packets (including bad packets) received that were between 128 and 255 octets in length inclusive (excluding framing bits but including FCS octets).
etherStatsPkts256to511Octets	The total number of packets (including bad packets) received that were between 256 and 511 octets in length inclusive (excluding framing bits but including FCS octets).
etherStatsPkts512to1023Octets	The total number of packets (including bad packets) received that were between 512 and 1023 octets in length inclusive (excluding framing bits but including FCS octets).
etherStatsPkts1024to1518Octets	The total number of packets (including bad packets) received that were between 1024 and 1518 octets in length inclusive (excluding framing bits but including FCS octets).
etherStatsBroadcastPkts	The total number of good packets received that were directed to the broadcast address. Note that this does not include multicast packets.

**Table 19-16 E-Series Ethernet Statistics Parameters (continued)**

Parameter	Definition
etherStatsMulticastPkts	The total number of good packets received that were directed to a multicast address. Note that this number does not include packets directed to the broadcast address.
etherStatsOversizePkts	The total number of packets received that were longer than 1518 octets (excluding framing bits, but including FCS octets) and were otherwise well formed. Note that for tagged interfaces, this number becomes 1522 bytes.
etherStatsJabbers	The total number of packets received that were longer than 1518 octets (excluding framing bits, but including FCS octets), and had either a bad FCS with an integral number of octets (FCS Error) or a bad FCS with a nonintegral number of octets (Alignment Error).
etherStatsOctets	The total number of octets of data (including those in bad packets) received on the network (excluding framing bits but including FCS octets).
etherStatsCRCAlignErrors	The total number of packets received that had a length (excluding framing bits, but including FCS octets) of between 64 and 1518 octets, inclusive, but had either a bad FCS with an integral number of octets (FCS Error) or a bad FCS with a nonintegral number of octets (Alignment Error).

**Note**

In certain congestion scenarios in GE\_XP and 10GE\_XP cards, dropped packets are counted both in ingress (IfIndiscards) and egress interface (IfOutDiscards) interface. As a result of this, some dropped packets are counted twice. The dropped packets on ingress interface can be ignored under this scenario.

### 19.2.4.2 Ether Ports Utilization Window

The Utilization window shows the percentage of transmit (Tx) and receive (Rx) line bandwidth used by the Ethernet ports during consecutive time segments. The Mode field displays the real-time mode status, such as 100 Full, which is the mode setting configured on the E-Series port. However, if the E-Series port is set to autonegotiate the mode (Auto), this field shows the result of the link negotiation between the E-Series and the peer Ethernet device attached directly to the E-Series port.

The Utilization window provides an Interval drop-down list that enables you to set time intervals of 1 minute, 15 minutes, 1 hour, and 1 day. Line utilization is calculated with the following formulas:

$$Rx = (\text{inOctets} + \text{inPkts} * 20) * 8 / 100\% \text{ interval} * \text{maxBaseRate}$$

$$Tx = (\text{outOctets} + \text{outPkts} * 20) * 8 / 100\% \text{ interval} * \text{maxBaseRate}$$

The interval is defined in seconds. The maxBaseRate is defined by raw bits per second in one direction for the Ethernet port (that is, 1 Gbps).

### 19.2.4.3 Ether Ports History Window

The Ether Port History window lists past Ethernet statistics for the previous time intervals. Depending on the selected time interval, the History window displays the statistics for each port for the number of previous time intervals as shown in [Table 19-17](#). The parameters are defined in [Table 19-16 on page 19-14](#).

**Table 19-17 Ethernet History Statistics per Time Interval**

Time Interval	Number of Previous Intervals Displayed
1 minute	60
15 minutes	32
1 hour	24
1 day (24 hours)	7

## 19.3 DWDM Card Performance Monitoring

The following sections define PM parameters and definitions for the ONS 15454 OPT-PRE, OPT-BST, OPT-BST-L, OPT-AMP-L, OPT-AMP-17-C, 32MUX-O, 32DMX-O, 32DMX, 32DMX-L, 40-WSS-C, 40-WSS-CE, 40-WXC-C, 40-DMX-C, 40-DMX-CE, 40-MUX-C, 40-SMR1-C, 40-SMR2-C, 4MD-xx.x, AD-1C-xx.x, AD-2C-xx.x, AD-4C-xx.x, AD-1B-xx.x, AD-4B-xx.x, OSCM, OSC-CSM, 32WSS, and 32WSS-LDWDM cards.

### 19.3.1 Optical Amplifier Card Performance Monitoring Parameters

The PM parameters for the OPT-PRE, OPT-AMP-L, OPT-AMP-17-C, OPT-BST, and OPT-BST-L cards are listed [Table 19-18](#). For ONS 15454 optics definitions, see the “[19.4 Optics and 8b10b PM Parameter Definitions](#)” section on page 19-21.

**Table 19-18 Optical PM Parameters for Optical Amplifier Cards**

Optical Line	Optical Amplifier Line
OPT	OPR

### 19.3.2 Multiplexer and Demultiplexer Card Performance Monitoring Parameters

The PM parameters for the 32MUX-O, 32WSS, 32WSS-L, 32DMX, 32DMX-L, 32DMX-O, 40-WSS-C, 40-WSS-CE, 40-WXC-C, 40-DMX-C, 40-DMX-CE, 40-MUX-C, 40-SMR1-C, and 40-SMR2-C cards are listed in [Table 19-19](#). For ONS 15454 optics definitions, see the “[19.4 Optics and 8b10b PM Parameter Definitions](#)” section on page 19-21.

**Table 19-19 Optical PM Parameters of Multiplexer and Demultiplexer Cards**

Optical Channel	Optical Line
OPR	OPT

### 19.3.3 4MD-xx.x Card Performance Monitoring Parameters

The PM parameters for the 4MD-xx.x cards are listed in [Table 19-20](#). For ONS 15454 optics definitions, see the “[19.4 Optics and 8b10b PM Parameter Definitions](#)” section on page 19-21.

**Table 19-20** Optical PM Parameters for 4MD-xx.x Cards

Optical Channel	Optical Band
OPR	OPT

## 19.3.4 OADM Channel Filter Card Performance Monitoring Parameters

The PM parameters for the AD-1C-xx.x, AD-2C-xx.x, and AD-4C-xx.x cards are listed in [Table 19-21](#). For ONS 15454 optics definitions, see the “[19.4 Optics and 8b10b PM Parameter Definitions](#)” section on page 19-21.

**Table 19-21** Optical PM Parameters for AD-1C-xx.x, AD-2C-xx.x, and AD-4C-xx.x Cards

Optical Channel	Optical Line
OPR	OPT

## 19.3.5 OADM Band Filter Card Performance Monitoring Parameters

The PM parameters for the AD-1B-xx.x and AD-4B-xx.x cards are listed in [Table 19-22](#). For ONS 15454 optics definitions, see the “[19.4 Optics and 8b10b PM Parameter Definitions](#)” section on page 19-21.

**Table 19-22** Optical PM Parameters for AD-1B-xx.x and AD-4B-xx.x Cards

Optical Line	Optical Band
OPR	OPT

## 19.3.6 Optical Service Channel Card Performance Monitoring Parameters

For ONS 15454 ANSI nodes, [Figure 19-3](#) shows where overhead bytes detected on the ASICs produce PM parameters for the OSCM and OSC-CSM cards.

**Figure 19-3** ONS 15454 ANSI Node PM Read Points on OSCM and OSC-CSM Cards

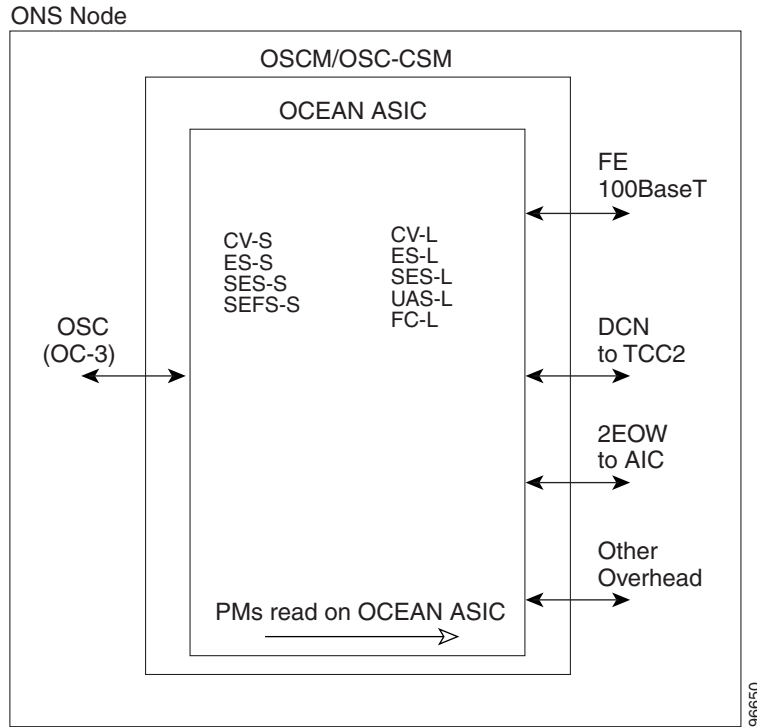

For ONS 15454 ETSI nodes, [Figure 19-4](#) shows where overhead bytes detected on the ASICs produce PM parameters for the OSCM and OSC-CSM cards.

Figure 19-4 ONS 15454 ETSI Node PM Read Points on OSCM and OSC-CSM Cards

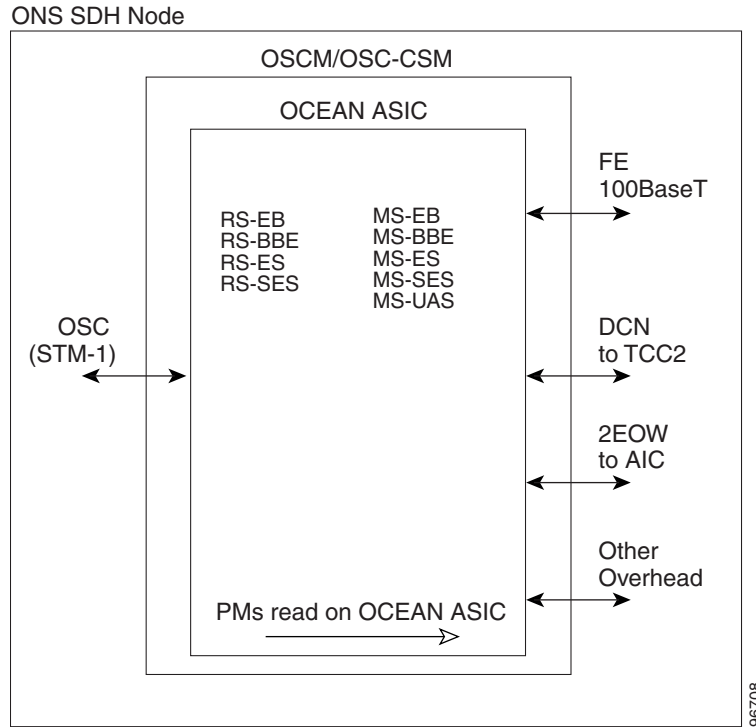

The ONS 15454 ANSI node PM parameters for the OSCM and OSC-CSM cards are listed in Table 19-23. For PM definitions, see the “19.8 SONET PM Parameter Definitions” section on page 19-27. For optics PM definitions, see the “19.4 Optics and 8b10b PM Parameter Definitions” section on page 19-21.

Table 19-23 ANSI OSCM/OSC-CSM (OC3) Card PMs

Section (Near End) <sup>1</sup>	Line (Near End/Far End) <sup>1</sup>	Optics (Near End) <sup>2</sup>
CV-S ES-S SEF-S SES-S	CV-L ES-L FC-L SES-L UAS-L	OPWR

1. Applicable to OC3
2. Applicable to OTS facilities

Table 19-24 ETSI OSCM and OSC-CSM Card PMs

Regeneration Section (Near End)	Multiplex Section (Near End/Far End)	Optics (Near End)
RS-BBE RS-EB RS-ES RS-SES	MS-BBE MS-EB MS-ES MS-SES MS-UAS	OPT

## 19.4 Optics and 8b10b PM Parameter Definitions

Table 19-25 on page 19-21 lists Cisco ONS 15454 optics and 8b10b PM parameter definitions.

**Table 19-25 ONS 15454 Optics and 8b10b PM Parameter Definitions**

Parameter	Definition
8b10bDataOrderedSets	8b10b takes 8 bits of data and sends it as 10 bits, which allows control information to be sent along with the data. DataOrderedSets is a count of data ordered sets.
8b10bErrors	8b10b takes 8 bits of data and sends it as 10 bits, which allows control information to be sent along with the data. Errors is a count of 10b errors received by the serial or deserializer (serdes 8b/10b).
8b10bIdleOrderedSets	8b10b takes 8 bits of data and sends it as 10 bits, which allows control information to be sent along with the data. IdleOrderedSets is a count of idle ordered sets.
8b10bInvalidOrderedSets	8b10b takes 8 bits of data and sends it as 10 bits, which allows control information to be sent along with the data. InvalidOrderedSets is a count of the received invalid work errors.
8b10bNonIdleOrderedSets	8b10b takes 8 bits of data and sends it as 10 bits, which allows control information to be sent along with the data. NonIdleOrderedSets is a count of ordered sets that are not idle.
8b10bStatsEncodingDispErrors	8b10b takes 8 bits of data and sends it as 10 bits, which allows control information to be sent along with the data. StatsEncodingDispErrors is a count of the received disparity errors.
BIE	The number of bit errors (BIE) corrected in the DWDM trunk line during the PM time interval.
BIT-EC	The number of Bit Errors Corrected (BIT-EC) in the DWDM trunk line during the PM time interval.
CGV	Code Group Violations (CGV) is a count of received code groups that do not contain a start or end delimiter.
DCG	Date Code Groups (DCG) is a count of received data code groups that do not contain ordered sets.
IOS	Idle Ordered Sets (IOS) is a count of received packets containing idle ordered sets.
IPC	Invalid Packets (IPC) is the count of received packets that contain errored data code groups that have start and end delimiters.
LBCL-AVG	Laser Bias Current Line-Average (LBCL-AVG) is the average percentage of laser bias current.
LBCL-MAX	Laser Bias Current Line-Maximum (LBCL-MAX) is the maximum percentage of laser bias current.
LBCL-MIN	Laser Bias Current Line-Minimum (LBCL-MIN) is the minimum percentage of laser bias current.

**Table 19-25 ONS 15454 Optics and 8b10b PM Parameter Definitions (continued)**

Parameter	Definition
LOFC	Loss of Frame Count (LOFC) is a count of the lost frames.
NIOS	Non-Idle Ordered Sets (NIOS) is a count of received packets containing non-idle ordered sets.
OPR	Optical Power Received (OPR) is the measure of average optical power received as a percentage of the nominal OPR.
OPR-AVG	Average Receive Optical Power (OPR-AVG) is the average received optical power measured in dBm.
OPR-MAX	Maximum Receive Optical Power (OPR-MAX) is the maximum received optical power measured in dBm.
OPR-MIN	Minimum Receive Optical Power (OPR-MIN) is the minimum received optical power measured in dBm.
OPT	Optical Power Transmitted (OPT) is the average optical power transmitted as a percentage of the nominal OPT.
OPT-AVG	Average Transmit Optical Power (OPT-AVG) is the average transmitted optical power measured in dBm.
OPT-MAX	Maximum Transmit Optical Power (OPT-MAX) is the maximum transmitted optical power measured in dBm.
OPT-MIN	Minimum Transmit Optical Power (OPT-MIN) is the minimum transmitted optical power measured in dBm.
OPWR-AVG	Optical Power - Average (OPWR-AVG) is the measure of average optical power on the unidirectional port.
OPWR-MAX	Optical Power - Maximum (OPWR-MAX) is the measure of maximum value of optical power on the unidirectional port.
OPWR-MIN	Optical Power - Minimum (OPWR-MIN) is the measure of minimum value of optical power on the unidirectional port.
UNC-WORDS	Uncorrectable Words (UNC-WORDS) is the number of uncorrectable words detected in the DWDM trunk line during the PM time interval.
VPC	Valid Packets (VPC) is a count of received packets that contain non-errored data code groups that have start and end delimiters.

## 19.5 ITU G.709 and ITU-T G.8021 Trunk-Side PM Parameter Definitions

Table 19-28 defines the ITU G.709 and ITU-T G.8021 section monitoring trunk-side PM parameters. For more information, see the “[19.2 Transponder, Muxponder, Xponder, and ADM-10G Card Performance Monitoring](#)” section on page 19-2.

**Table 19-26 ITU G.709 and ITU-T G.8021 Section Monitoring PM Definitions**

Parameter	Definition
BBE-SM	Section Monitoring Background Block Errors (BBE-SM) shows the number of background block errors recorded in the OTN section during the PM time interval.
BBER-SM	Section Monitoring Background Block Errors Ratio (BBER-SM) shows the background block errors ratio recorded in the OTN path during the PM time interval.
ES-SM	Section Monitoring Errored Seconds (ES-SM) shows the errored seconds recorded in the OTN section during the PM time interval.
ESR-SM	Section Monitoring Errored Seconds Ratio (ESR-SM) shows the severely errored seconds ratio recorded in the OTN section during the PM time interval.
FC-SM	Section Monitoring Failure Counts (FC-SM) shows the failure counts recorded in the OTN section during the PM time interval.
SES-SM	Section Monitoring Severely Errored Seconds (SES-SM) shows the severely errored seconds recorded in the OTN section during the PM time interval.
SESR-SM	Section Monitoring Severely Errored Seconds Ratio (SESR-SM) shows the severely errored seconds ratio recorded in the OTN section during the PM time interval.
UAS-SM	Section Monitoring Unavailable Seconds (UAS-SM) shows the unavailable seconds recorded in the OTN section during the PM time interval.

Table 19-27 defines the ITU G.709 path monitoring trunk-side PM parameters. For more information, see the “19.2 Transponder, Muxponder, Xponder, and ADM-10G Card Performance Monitoring” section on page 19-2.

**Table 19-27 ITU G.709 Path Monitoring PM Definitions**

Parameter	Definition
BBE-PM	Path Monitoring Background Block Errors (BBE-PM) shows the number of background block errors recorded in the OTN path during the PM time interval.
BBER-PM	Path Monitoring Background Block Errors Ratio (BBER-PM) shows the background block errors ratio recorded in the OTN path during the PM time interval.
ES-PM	Path Monitoring Errored Seconds (ES-PM) shows the errored seconds recorded in the OTN path during the PM time interval.
ESR-PM	Path Monitoring Errored Seconds Ratio (ESR-PM) shows the severely errored seconds ratio recorded in the OTN path during the PM time interval.
FC-PM	Path Monitoring Failure Counts (FC-PM) shows the failure counts recorded in the OTN path during the PM time interval.

**Table 19-27** ITU G.709 Path Monitoring PM Definitions (continued)

Parameter	Definition
SES-PM	Path Monitoring Severely Errored Seconds (SES-PM) shows the severely errored seconds recorded in the OTN path during the PM time interval.
SESR-PM	Path Monitoring Severely Errored Seconds Ratio (SESR-PM) shows the severely errored seconds ratio recorded in the OTN path during the PM time interval.
UAS-PM	Path Monitoring Unavailable Seconds (UAS-PM) shows the unavailable seconds recorded in the OTN path during the PM time interval.

## 19.6 Full RMON Statistics PM Parameter Definitions

Table 19-28 defines the MXP\_MR\_2.5G, MXPP\_MR\_2.5G, TXP\_MR\_10E, TXP\_MR\_10E\_C, and TXP\_MR\_10E\_L card full RMON statistics PM parameters. For more information, see the “19.2 Transponder, Muxponder, Xponder, and ADM-10G Card Performance Monitoring” section on page 19-2.

**Table 19-28** Full RMON Statistics PM Definitions

Parameter	Definition
dot3StatsFCSErrors	The number of frames with frame check errors.
dot3StatsFrameTooLong	The number of packets at least 64 octets long, without a bad Frame Check Sequence (FCS), where the 802.3 length/type field did not match the computed DATA field length.
etherStatsBroadcastPkts	The number of broadcast packets, excluding multicast packets, that are 64–16376 octets in length, and have a valid FCS.
etherStatsCRCAlignErrors	The number of packets that are 64–1518 octets in length without an integral number of octets, or with a bad FCS.
etherStatsFragments	The number of packets less than 64 octets long that do not have an integral number of octets or that have a bad FCS.
etherStatsJabbers	The number of octets of data, including bad packets, that were received on the network.
etherStatsMulticastPkts	The number of multicast packets, excluding broadcast packets, that are 64–16376 octets in length, and have a valid FCS.
etherStatsOctets	The number in bytes of received packets, including bad packets and excluding framing bits except for FCS bytes.
etherStatsOversizePkts	The number of packets more than 16376 octets long that have a valid FCS.
etherStatsPkts64Octets	The number of packet received, including error packets, that are 64 octets in length.
etherStatsPkts65to127Octets	The number of packets received, including error packets, that are 65–127 octets in length.

**Table 19-28 Full RMON Statistics PM Definitions (continued)**

Parameter	Definition
etherStatsPkts128to255Octets	The number of packets received, including error packets, that are 128–255 octets in length.
etherStatsPkts256to511Octets	The number of packets received, including error packets, that are 256–511 octets in length.
etherStatsPkts512to1023Octets	The number of packets received, including error packets, that are 512–1023 octets in length.
etherStatsPkts1024to1518Octets	The number of packets received, including error packets, that are 1024–1518 octets in length.
etherStatsUndersizePkts	The number of packets less than 64 octets long that have a valid FCS.
fcStatsLinkRecoveries	The number of link recoveries.
fcStatsRxCredits	The number of current receive buffer to buffer credits.
fcStatsTxCredits	The number of current transmit buffer to buffer credits.
fcStatsZeroTxCredits	This is a count that increments when the FC/FICON Tx credits go from a nonzero value to zero.
gfpStatsLFDRaised	The number of loss of frame delineation (LFD) raised.
gfpStatsRoundTripLatencyUsec	Round trip delay for the end-to-end Fibre Channel transport in microseconds.
gfpStatsRxCRCErrors	The number of packets received with a payload FCS error.
gfpStatsRxCSFRaised	Received GFP loss of client character synchronization (LOCCS).
gfpStatsRxDistanceExtBuffers	The number of receive buffer credit for GFP-T (valid only if distance extension is enabled).
gfpStatsRxMBitErrors	The received multibit errored core header count (cHEC).
gfpStatsRxSBitErrors	The received single-bit errored cHEC.
gfpStatsRxSblkCRCErrors	The number of packets received with a payload FCS error. Sblk stands for super block in the GFP payload.
gfpStatsRxTypeInvalid	Received invalid type.
gfpStatsTxDistanceExtBuffers	The number of transmit buffer credit for GFP-T (valid only if distance extension is enabled).
ifInBroadcastPkts	The number of packets delivered to a higher sublayer and addressed to a broadcast address at this sublayer.
ifInDiscards	The number of inbound packets that were chosen to be discarded even though no errors were detected, to prevent them from being deliverable to a higher-layer protocol. One possible reason for discarding such a packet could be to free buffer space.
ifInErrors	The number of inbound packets (or transmission units) that contained errors preventing them from being delivered to a higher-layer protocol.
ifInErrorBytePkts	The number of received packets with an error symbol detected.

**Table 19-28 Full RMON Statistics PM Definitions (continued)**

Parameter	Definition
ifInFramingErrorPkts	The number of received packets with a control symbol other than an error detected.
ifInJunkInterPkts	The number of interpacket gaps between valid start symbols during which a symbol other than idle is detected, including packets of length 1–8 octets.
ifInMulticastPkts	The total number of multicast frames received error-free.
ifInOctets	The number of bytes received since the last counter reset.
ifOutBroadcastPkts	The number of packets requested by higher-level protocols and addressed to a broadcast address at this sublayer, including those not transmitted.
ifOutDiscards	The number of outbound packets that were chosen to be discarded even though no errors had been detected to prevent their being transmitted. One possible reason for discarding such a packet could be to free buffer space.
ifOutMulticastPkts	The number of multicast frames transmitted error-free.
ifOutOctets	The number of bytes transmitted since the last counter reset.
InvalidCRCError	A count of invalid cyclic redundancy checks (CRCs).
mediaIndStatsRxFramesBadCRC	The number of received frames with a CRC error.
mediaIndStatsRxFramesTooLong	The number of received frames that are too long.
mediaIndStatsRxFramesTruncated	The number of received frames that are too small.
mediaIndStatsTxFramesBadCRC	The number of transmitted frames with a CRC error.
Running Disparity Count	A count of errors that affect the disparity of the received data stream.
rxControlFrames	The number of MAC control packets that are type 0x8808 and contain at least 64 octets in length.
rxFrames	A count of the number of frames received without errors.
rxLinkReset (Only for FC Mode)	A count of the received link resets.
rxPauseFrames	The number of received 802.x paused frames.
rxTotalPkts	The number of received packets.
rxUnknownOpcodeFrames	Number of packets of at least 64 octets in length and type 0x8808, with opcode not equal to 1.
Time Last Cleared	A time stamp indicating the last time statistics were reset.
txBytes	A count of the number of bytes transmitted from the frame since the last counter reset.
txFrames	A count of the number of transmitted frames.
txTotalPkts	The number of transmitted packets.

## 19.7 FEC PM Parameter Definitions

Table 19-29 defines the MXP\_MR\_2.5G, MXPP\_MR\_2.5G, TXP\_MR\_10E, TXP\_MR\_10E\_C, and TXP\_MR\_10E\_L card FEC PM parameters. For more information, see the “19.2 Transponder, Muxponder, Xponder, and ADM-10G Card Performance Monitoring” section on page 19-2.

**Table 19-29** FEC PM Definitions

Parameter	Definition
Bit Errors	Bit Errors are the number of bit errors corrected.
FEC (NE)	<p>FEC enables correction and detection of errors along the optical links where OTN and FEC are provisioned. FEC uses Reed Solomon code RS (255,239) encoding. The FEC field is found in Rows 1 to 4 and Columns 3835 to 4080. It will contain either the Reed-Solomon RS(255,239) codes, or if FEC is disabled, fixed stuff bytes (zeros).</p> <p><b>Note</b> The FEC PM information can be found in the card view Performance &gt; OTN PM tab. FEC must be enabled on the transponder units in order for FEC PM values to be reported.</p>
UNC-Words	Uncorrectable Words (UNC-Words) occur when FEC detects and corrects errors to deliver a 7 to 8 dB improvement in the signal-to-noise ratio (also called margin). For ITU G.709, the FEC code used is Reed-Solomon RS (255, 239).

## 19.8 SONET PM Parameter Definitions

Table 19-30 gives definitions for each type of SONET PM parameter available on an ONS 15454 ANSI node. These parameters become available when the client type is set to OC-3, OC-12, or OC-48 on a TXP\_MR\_2.5G or TXPP\_MR\_2.5G card or to OC-192 on a TXP\_MR\_10G, TXP\_MR\_10E, TXP\_MR\_10E\_C, TXP\_MR\_10E\_L, or ADM-10G card. The OC-48 client PM is available on MXP\_2.5\_10G, MXP\_2.5G\_10E, MXP\_2.5G\_10E\_C, MXP\_2.5G\_10E\_L, MXP\_MR\_10DME\_C, and MXP\_MR\_10DME\_L cards. The OC-48 trunk PM is available on MXP\_MR\_2.5G and MXPP\_MR\_2.5G cards.

**Table 19-30** SONET PM Parameters

Parameter	Definition
CV-L	Line Coding Violation (CV-L) indicates the number of coding violations occurring on the line. This parameter is a count of bipolar violations (BPVs) and excessive zeros (EXZs) occurring over the accumulation period.
CV-S	Section Coding Violation (CV-S) is a count of bit interleaved parity (BIP) errors detected at the section layer (that is, using the B1 byte in the incoming SONET signal). Up to eight section BIP errors can be detected per STS-N frame; each error increments the current CV-S second register.

**Table 19-30 SONET PM Parameters (continued)**

Parameter	Definition
ES-L	Line Errored Seconds (ES-L) is a count of the seconds containing one or more anomalies (BPV + EXZ) and/or defects (that is, loss of signal) on the line.
ES-S	Section Errored Seconds (ES-S) is a count of the number of seconds when at least one section-layer BIP error was detected or an SEF or loss of signal (LOS) defect was present.
FC-L	Line Failure Count (FC-L) is a count of the number of near-end line failure events. A failure event begins when an Alarm Indication Signal Line (AIS-L) failure is declared or when a lower-layer, traffic-related, near-end failure is declared. This failure event ends when the failure is cleared. A failure event that begins in one period and ends in another period is counted only in the period where it begins.
SEF-S	Severely Errored Framing Seconds (SEFS-S) is a count of the seconds when an SEF defect was present. An SEF defect is expected to be present during most seconds when an LOS or loss of frame (LOF) defect is present. However, there can be situations when the SEFS-S parameter is only incremented based on the presence of the SEF defect.  <b>Note</b> The RTRV-PM-<MOD2> command does not retrieve SEF-S counter for OC192/STM64 payloads on ADM-10G and OTU2-XP cards.
SES-L	Line Severely Errored Seconds (SES-L) is a count of the seconds containing more than a particular quantity of anomalies (BPV + EXZ $\geq$ 44) and/or defects on the line.
SES-S	Section Severely Errored Seconds (SES-S) is a count of the seconds when K (see Telcordia GR-253 for value) or more section-layer BIP errors were detected or an SEF or LOS defect was present.
UAS-L	Line Unavailable Seconds (UAS-L) is a count of the seconds when the line is unavailable. A line becomes unavailable when ten consecutive seconds occur that qualify as SES-Ls, and it continues to be unavailable until ten consecutive seconds occur that do not qualify as SES-Ls.

## 19.9 SDH PM Parameter Definitions

Table 19-31 gives definitions for each type of SDH PM parameter available on an ONS 15454 ETSI node. These parameters become available when the client type is set to STM-1, STM-4, or STM-16 on a TXP\_MR\_2.5G or TXPP\_MR\_2.5G card or to STM-64 on a TXP\_MR\_10G, TXP\_MR\_10E, TXP\_MR\_10E\_C, TXP\_MR\_10E\_L, or ADM-10G card. The STM-16 client PM is available on

MPX\_2.5G\_10G, MPX\_2.5G\_10E, MPX\_2.5G\_10E\_C, MPX\_2.5G\_10E\_L, MPX\_MR\_10DME\_C, and MPX\_MR\_10DME\_L cards. The STM-16 trunk PM is available on MPX\_MR\_2.5G and MPX\_MR\_2.5G cards.

**Table 19-31 SDH PM Parameters**

Parameter	Definition
MS-BBE	Multiplex Section Background Block Error (MS-BBE) is an errored block not occurring as part of an SES.
MS-BBER	Multiplex Section Background Block Error Ratio (MS-BBER) is the ratio of BBE to total blocks in available time during a fixed measurement interval. The count of total blocks excludes all blocks during SESs.
MS-EB	Multiplex Section Errored Block (MS-EB) indicates that one or more bits are in error within a block.
MS-ES	Multiplex Section Errored Second (MS-ES) is a one-second period with one or more errored blocks or at least one defect.
MS-ESR	Multiplex Section Errored Second Ratio (MS-ESR) is the ratio of errored seconds to total seconds in available time during a fixed measurement interval.
MS-SES	Multiplex Section Severely Errored Second (MS-SES) is a one-second period that contains 30 percent or more errored blocks or at least one defect. SES is a subset of ES. For more information, refer to ITU-T G.829 Section 5.1.3.
MS-SESR	Multiplex Section Severely Errored Second ratio (MS-SESR) is the ratio of SES to total seconds in available time during a fixed measurement interval.
MS-UAS	Multiplex Section Unavailable Seconds (MS-UAS) is a count of the seconds when the section was unavailable. A section becomes unavailable when ten consecutive seconds occur that qualify as MS-SESs, and it continues to be unavailable until ten consecutive seconds occur that do not qualify as MS-SESs. When the condition is entered, MS-SESs decrement and then count toward MS-UAS.
RS-BBE	Regenerator Section Background Block Error (RS-BBE) is an errored block not occurring as part of an SES.
RS-BBER	Regenerator Section Background Block Error Ratio (RS-BBER) is the ratio of BBE to total blocks in available time during a fixed measurement interval. The count of total blocks excludes all blocks during SESs.
RS-EB	Regenerator Section Errored Block (RS-EB) indicates that one or more bits are in error within a block.
RS-ES	Regenerator Section Errored Second (RS-ES) is a one-second period with one or more errored blocks or at least one defect.
RS-ESR	Regenerator Section Errored Second Ratio (RS-ESR) is the ratio of errored seconds to total seconds in available time during a fixed measurement interval.
RS-SES	Regenerator Section Severely Errored Second (RS-SES) is a one-second period which contains 30 percent or more errored blocks or at least one defect. SES is a subset of ES.

**Table 19-31 SDH PM Parameters (continued)**

Parameter	Definition
RS-SESR	Regenerator Section Severely Errored Second Ratio (RS-SESR) is the ratio of SES to total seconds in available time during a fixed measurement interval.
RS-UAS	Regenerator Section Unavailable Second (RS-UAS) is a count of the seconds when the regenerator section was unavailable. A section becomes unavailable when ten consecutive seconds occur that qualify as RS-UASs, and it continues to be unavailable until ten consecutive seconds occur that do not qualify as RS-UASs.

## 19.10 Pointer Justification Count Performance Monitoring

For the MultiService Transport Platform (MSTP), only the MXP\_2.5G\_10G card uses pointer justification counts. Pointers are used to compensate for frequency and phase variations. Pointer justification counts indicate timing errors on networks. When a network is out of synchronization, jitter and wander occur on the transported signal. Excessive wander can cause terminating equipment to slip.

Slips cause different effects in service. Voice service has intermittent audible clicks. Compressed voice technology has short transmission errors or dropped calls. Fax machines lose scanned lines or experience dropped calls. Digital video transmission has distorted pictures or frozen frames. Encryption service loses the encryption key, causing data to be transmitted again.

For ONS 15454 ANSI nodes, pointers provide a way to align the phase variations in STS and VT payloads. The STS payload pointer is located in the H1 and H2 bytes of the line overhead. Clocking differences are measured by the offset in bytes from the pointer to the first byte of the STS synchronous payload envelope (SPE) called the J1 byte. Clocking differences that exceed the normal range of 0 to 782 can cause data loss.

For ONS 15454 ETSI nodes, pointers provide a way to align the phase variations in VC4 payloads. The VC4 payload pointer is located in the H1 and H2 bytes of the AU pointers section and is a count of the number of bytes the VC4 path overhead (POH) J1 byte is away from the H3 byte, not including the section overhead bytes. Clocking differences are measured by the offset in bytes from the pointer to the first byte of the VC4 POH called the J1 byte. Clocking differences that exceed the normal range of 0 to 782 can cause data loss.

There are positive (PPJC) and negative (NPJC) pointer justification count parameters. PPJC is a count of path-detected (PPJC-PDET-P) or path-generated (PPJC-PGEN-P) positive pointer justifications. NPJC is a count of path-detected (NPJC-PDET-P) or path-generated (NPJC-PGEN-P) negative pointer justifications depending on the specific PM name. PJCDIFF is the absolute value of the difference between the total number of detected pointer justification counts and the total number of generated pointer justification counts. PJCS-PDET-P is a count of the one-second intervals containing one or more PPJC-PDET or NPJC-PDET. PJCS-PGEN-P is a count of the one-second intervals containing one or more PPJC-PGEN or NPJC-PGEN.

A consistent pointer justification count indicates clock synchronization problems between nodes. A difference between the counts means that the node transmitting the original pointer justification has timing variations with the node detecting and transmitting this count. For ONS 15454 SONET nodes, positive pointer adjustments occur when the frame rate of the SPE is too slow in relation to the rate of the STS-1. For ONS 15454 SDH nodes, positive pointer adjustments occur when the frame rate of the path overhead (POH) is too slow in relation to the rate of the VC4.

In CTC, the count fields for PPJC and NPJC PMs appear white and blank unless they are enabled on the card view Provisioning tab.