



## Node Reference

---

This chapter explains the ONS 15454 dense wavelength division multiplexing (DWDM) node types that are available for the ONS 15454. The DWDM node type is determined by the type of amplifier and filter cards that are installed in an ONS 15454. The chapter also explains the DWDM automatic power control, ROADM power equalization, span loss verification, and automatic node setup functions.



**Note**

---

Unless otherwise specified, “ONS 15454” refers to both ANSI and ETSI shelf assemblies.

---

Chapter topics include:

- [17.1 DWDM Node Configurations, page 17-1](#)
- [17.2 DWDM and TDM Hybrid Node Types, page 17-14](#)
- [17.3 Automatic Node Setup, page 17-29](#)

## 17.1 DWDM Node Configurations

The ONS 15454 supports the following DWDM node configurations: hub, terminal, OADM, reconfigurable OADM, anti-ASE, line amplifier, and OSC regeneration line.



**Note**

---

The Cisco MetroPlanner tool creates a plan for amplifier placement and proper node equipment.

---

### 17.1.1 Hub Node

A hub node is a single ONS 15454 node equipped with two TCC2/TCC2P (Timing Control Card) cards and one of the following combinations:

- Two 32MUX-O (32-Channel Multiplexer) and two 32DMX-O (32-Channel Demultiplexer) or 32DMX cards
- Two 32WSS (32-Channel Wavelength Selective Switch) and two 32DMX or 32DMX-O cards



**Note**

---

The 32WSS and 32DMX are normally installed in reconfigurable OADM (ROADM) nodes, but they can be installed in hub and terminal nodes. If the cards are installed in a hub node, the 32WSS express (EXP RX and EXP TX) ports are not cabled.

---

A Dispersion Compensation Unit (DCU) can also be added, if necessary. The hub node does not support both DWDM and time-division multiplexing (TDM) applications since the DWDM slot requirements do not leave room for TDM cards. [Figure 17-1](#) shows a hub node configuration with 32MUX-O and 32DMX-O cards installed.

**Note**

The optical add/drop multiplexing (OADM) AD-xC-xx.x or AD-xB-xx.x cards are not part of a hub node because the 32MUX-O and 32DMX-O cards drop and add all 32 channels; therefore, no other cards are necessary.

**Figure 17-1 Hub Node Configuration Example**

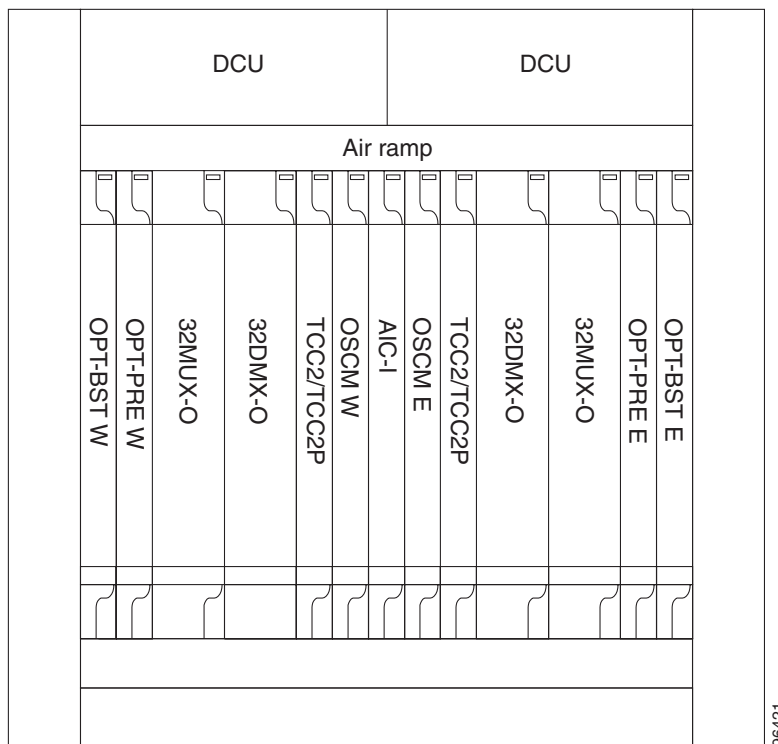

[Figure 17-2](#) shows the channel flow for a hub node. Up to 32-channels from the client ports are multiplexed and equalized onto one fiber using the 32MUX-O card. Then, multiplexed channels are transmitted on the line in the eastward direction and fed to the Optical Booster (OPT-BST) amplifier. The output of this amplifier is combined with an output signal from the Optical Service Channel Modem (OSCM) card and transmitted toward the east line.

Received signals from the east line port are split between the OSCM card and an Optical Pre-amplifier (OPT-PRE). Dispersion compensation is applied to the signal received by the OPT-PRE amplifier, and it is then sent to the 32DMX-O card, which demultiplexes and attenuates the input signal. The west receive fiber path is identical through the west OPT-BST amplifier, the west OPT-PRE amplifier, and the west 32DMX-O card.





**Figure 17-4 Amplified OADM Node Configuration Example**

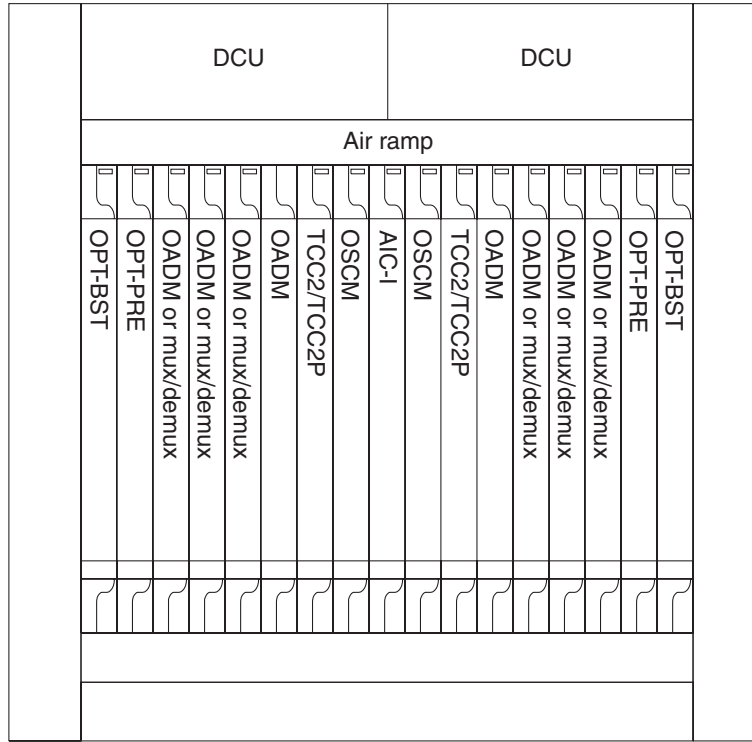

Figure 17-5 shows an example of the channel flow on the amplified OADM node. Since the 32-wavelength plan is based on eight bands (each band contains four channels), optical adding and dropping can be performed at the band level and/or at the channel level (meaning individual channels can be dropped).

Figure 17-5 Amplified OADM Node Channel Flow Example

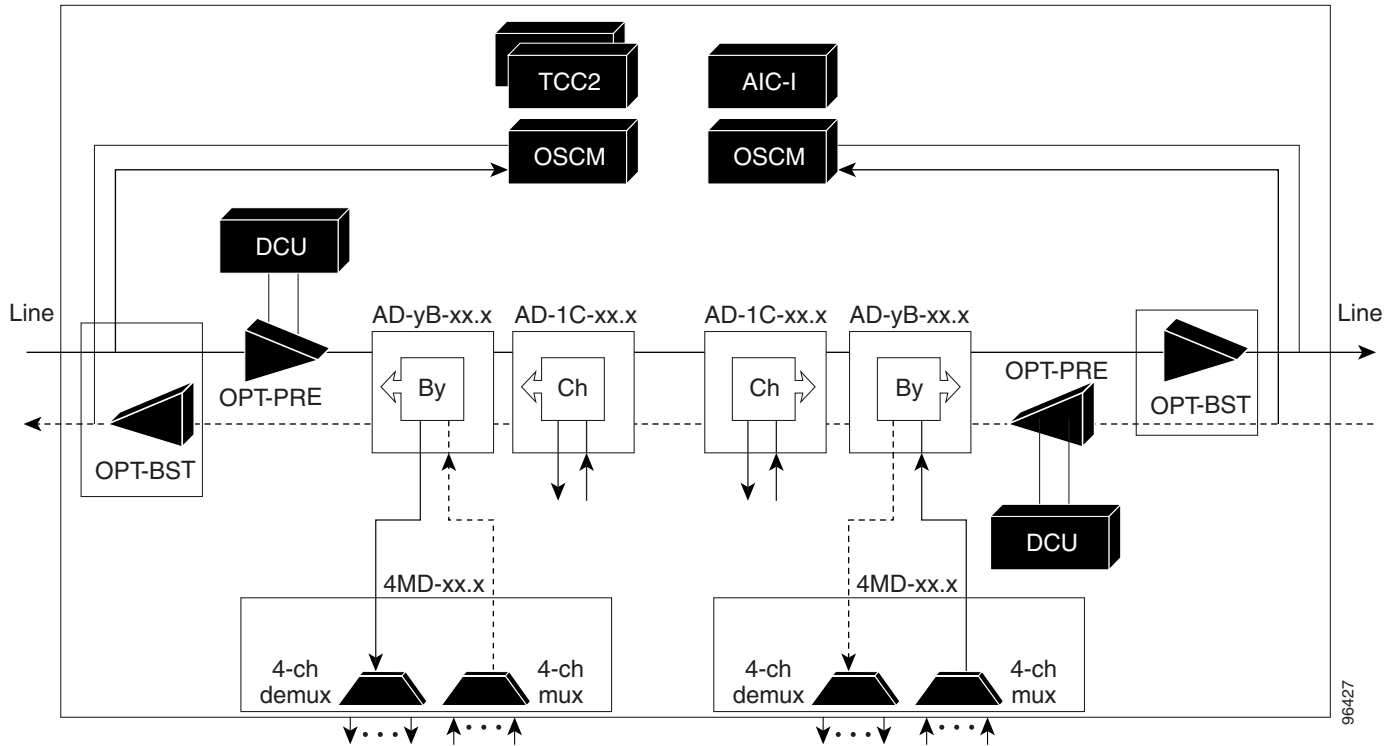

Figure 17-6 shows an example of a passive OADM node configuration. The passive OADM node is equipped with a band filter, one four-channel multiplexer/demultiplexer, and a channel filter on each side of the node.

**Figure 17-6** *Passive OADM Node Configuration Example*

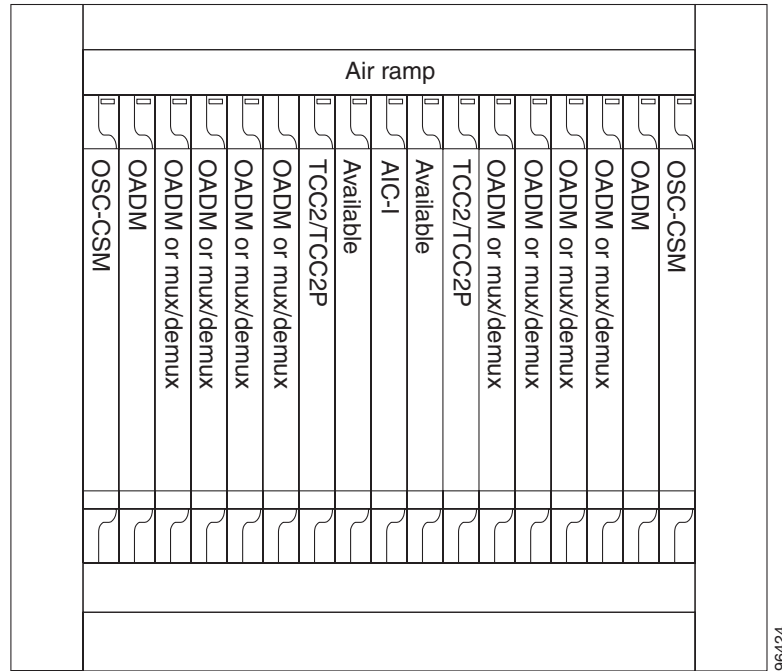
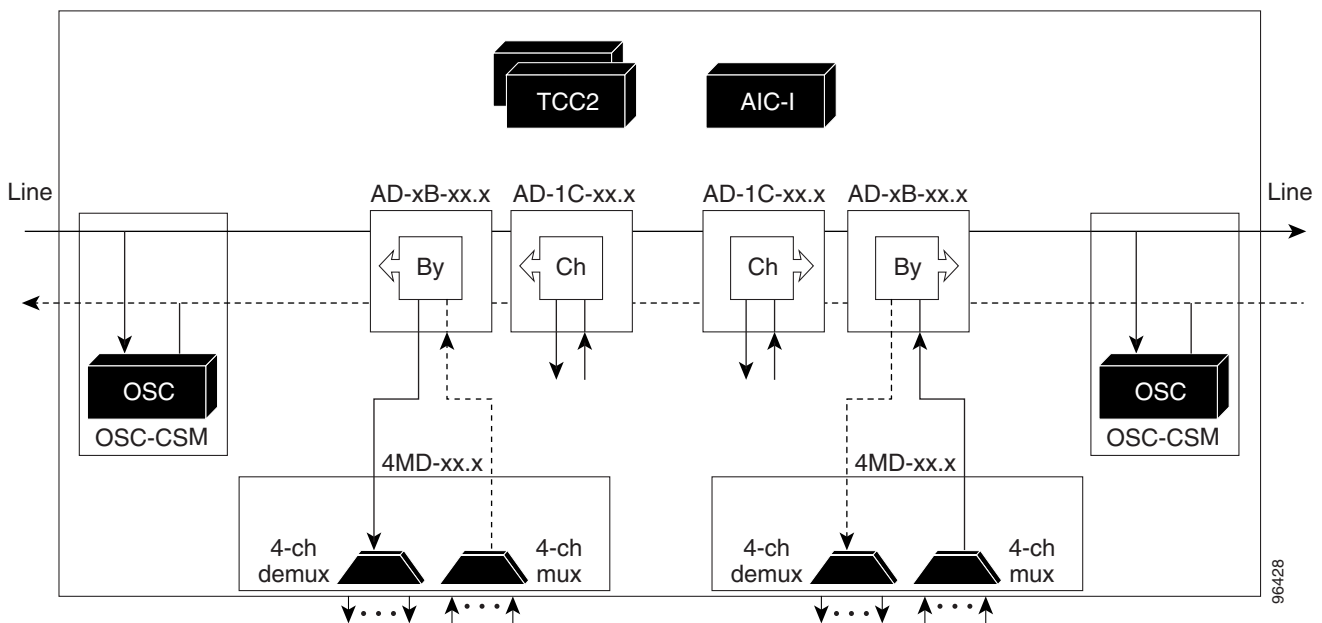

Figure 17-7 shows an example of traffic flow on the passive OADM node. The signal flow of the channels is the same as the amplified OADM, except that the Optical Service Channel and Combiner/Separator Module (OSC-CSM) card is used instead of the OPT-BST amplifier and the OSCM card.

**Figure 17-7** *Passive OADM Node Channel Flow Example*



## 17.1.4 ROADM Node

A reconfigurable OADM (ROADM) node allows you to add and drop wavelengths without changing the physical fiber connections. ROADM nodes are equipped with two 32WSS cards. 32DMX or 32DMX-O demultiplexers are typically installed, but are not required. Transponders (TXPs) and muxponders (MXPs) can be installed in Slots 6 and 12 and, if amplification is not used, in any open slot. [Figure 17-8](#) shows an example of an amplified ROADM node configuration.

Both 32DMX-O and 32-DMX cards can be used in ROADM nodes. Cisco MetroPlanner automatically determines at ROADM Node level which Demultiplexer to use based on the overall Network design.



### Note

Both 32DMX-O and 32DMX cards can be used in an ROADM node. Cisco Metroplanner automatically chooses the demultiplexer to use for the ROADM node based on the overall network requirements.

**Figure 17-8** ROADM Node with BST-PRE, OPT-BST, and 32DMX Cards Installed

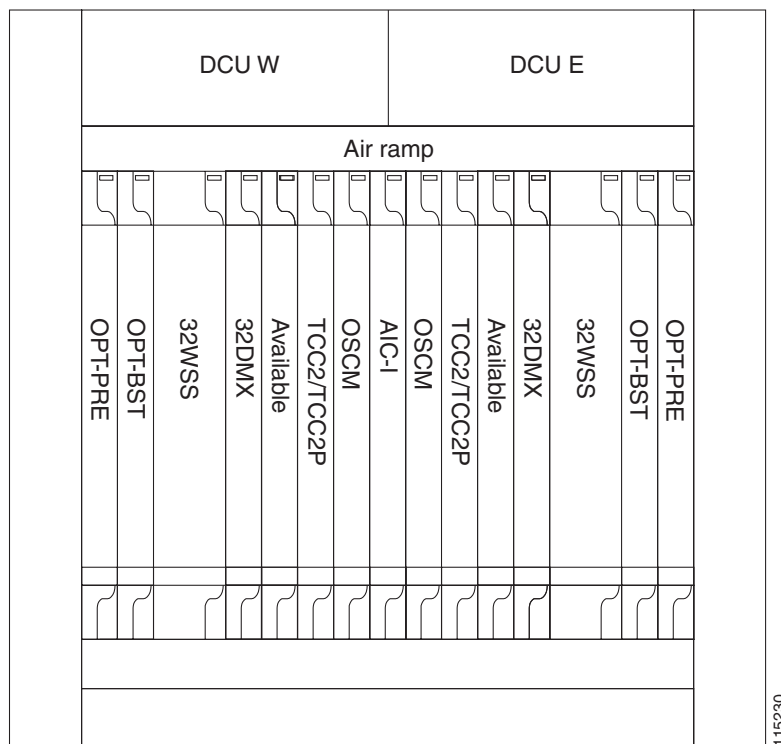

Figure 17-9 shows an example of an ROADM with 32DMX-O cards installed.

**Figure 17-9 ROADM Node with BST-PRE, OPT-BST, and 32DMX-O Cards Installed**

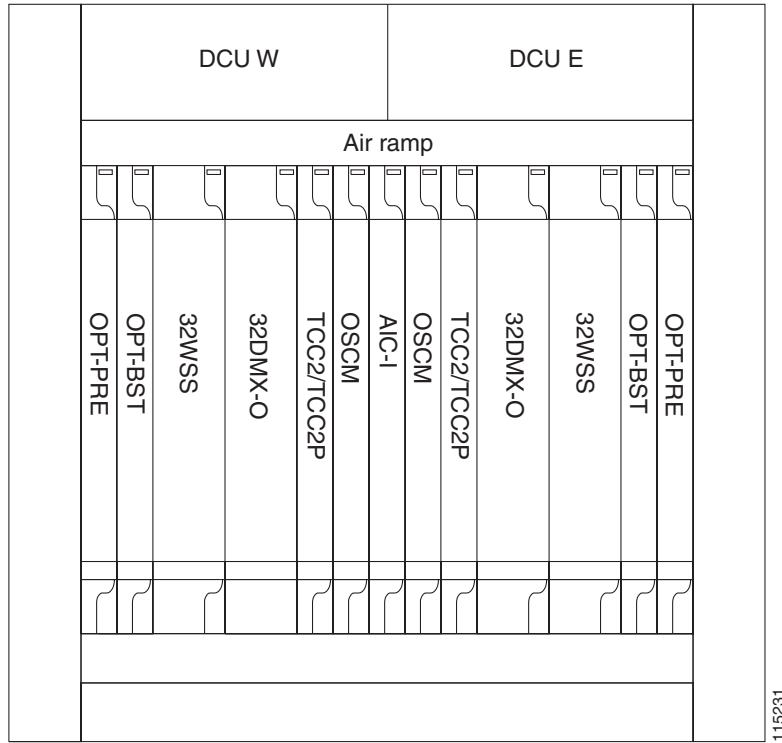
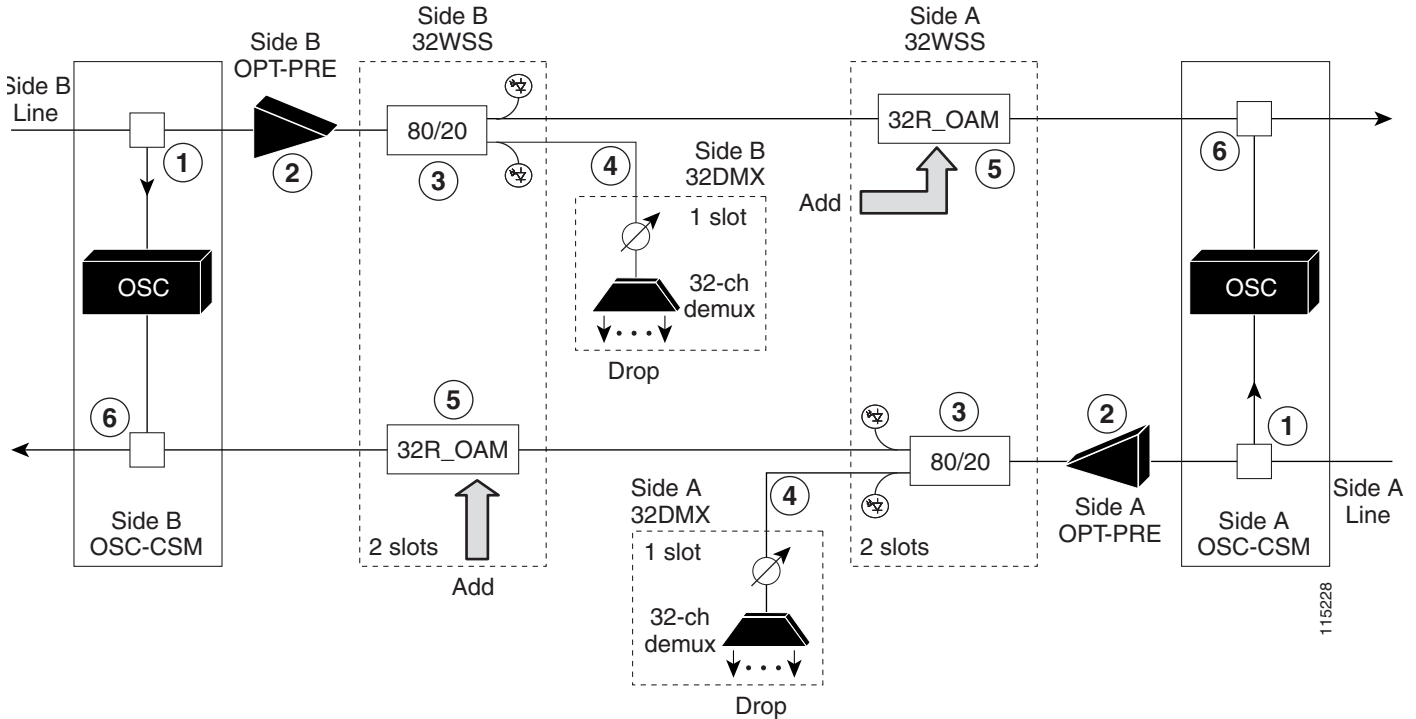

Figure 17-10 shows an example of a reconfigurable OADM east-to-west optical signal flow. The west-to-east optical signal flow follows an identical path through the west OSC-CSM and west 32WSS modules. In this example, OSC-CSM modules are installed so OPT-BST modules are not needed.

Figure 17-10 ROADM Optical Signal Flow Example



1	The OSC-CSM receives the optical signal. It separates the optical service channel from the optical payload and sends the payload to the OPT-PRE module.
2	The OPT-PRE compensates for chromatic dispersion, amplifies the optical payload, and sends it to the 32WSS.
3	The 32WSS splits the signal into two components. The 80% component is sent to the DROP-TX port and the 20% component is sent to the EXP-TX port.
4	The drop component goes to the 32DMX where it is de-multiplexed and dropped.
5	The express wavelength aggregate signal goes to the 32WSS on the other side where it is de-multiplexed. Channels are stopped or forwarded based upon their switch states. Forwarded wavelengths are merged with those coming from the ADD path and sent to the OSC-CSM module.
6	The OSC-CSM combines the multiplexed payload with the OSC and sends the signal out the transmission line.

## 17.1.5 Anti-ASE Node

In a meshed ring network, the ONS 15454 requires a node configuration that prevents amplified spontaneous emission (ASE) accumulation and lasing. An anti-ASE node can be created by configuring a hub node or an OADM node with some modifications. No channels can travel through the express path, but they can be demultiplexed and dropped at the channel level on one side and added and multiplexed on the other side.

The hub node is the preferred node configuration when some channels are connected in passthrough mode. For rings that require a limited number of channels, combine AD-xB-xx.x and 4MD-xx.x cards, or cascade AD-xC-xx.x cards. See [Figure 17-5 on page 17-6](#).

[Figure 17-11](#) shows an anti-ASE node that uses all wavelengths in the passthrough mode. Use Cisco MetroPlanner to determine the best configuration for anti-ASE nodes.

Figure 17-11 Anti-ASE Node Channel Flow Example

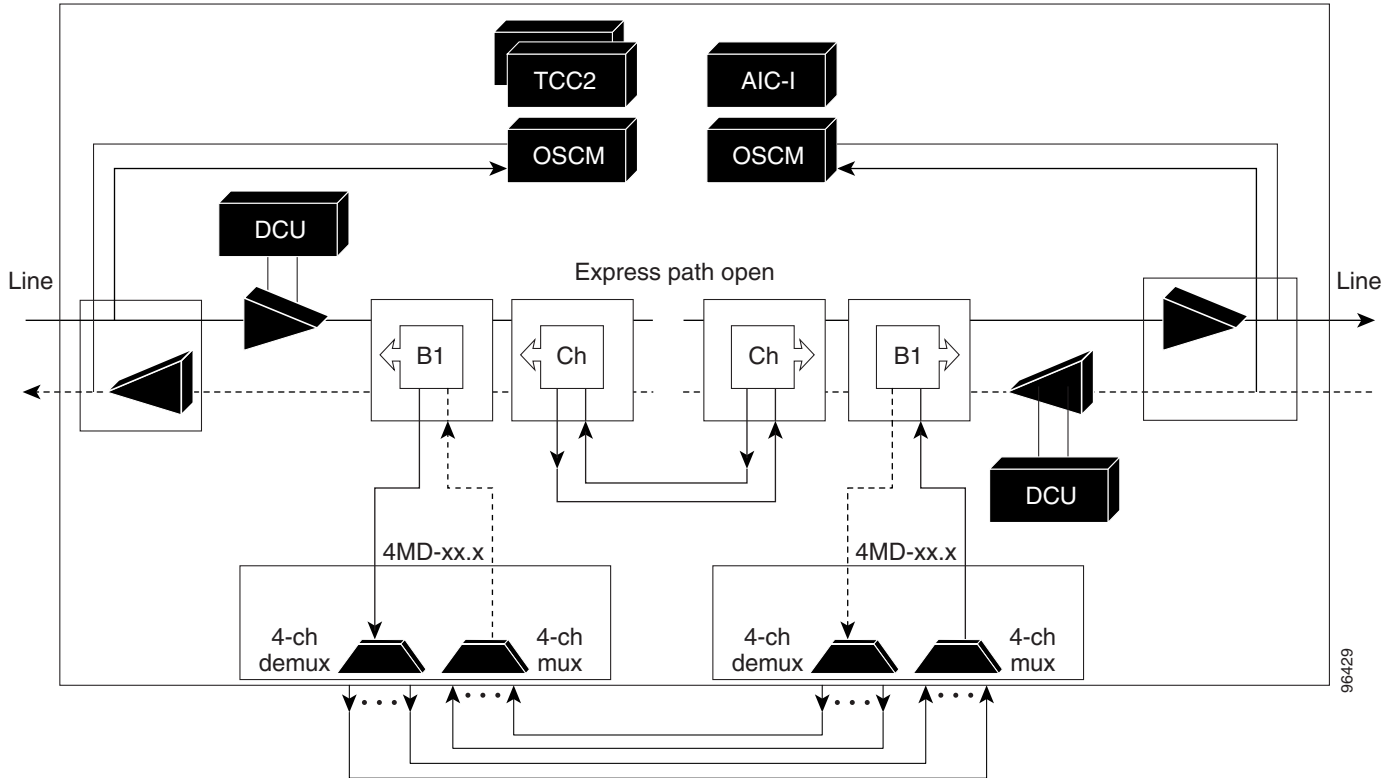

## 17.1.6 Line Amplifier Node

A line amplifier node is a single ONS 15454 node equipped with OPT-PRE amplifiers or OPT-BST amplifiers and TCC2/TCC2P cards. Attenuators might also be required between each preamplifier and booster amplifier to match the optical input power value and to maintain the amplifier gain tilt value.

Two OSCM cards are connected to the east or west ports of the booster amplifiers to multiplex the optical service channel (OSC) signal with the pass-through channels. If the node does not contain OPT-BST amplifiers, you must use OSC-CSM cards rather than OSCM cards in your configuration. [Figure 17-12](#) shows an example of a line node configuration.

Figure 17-12 Line Amplifier Node Configuration Example

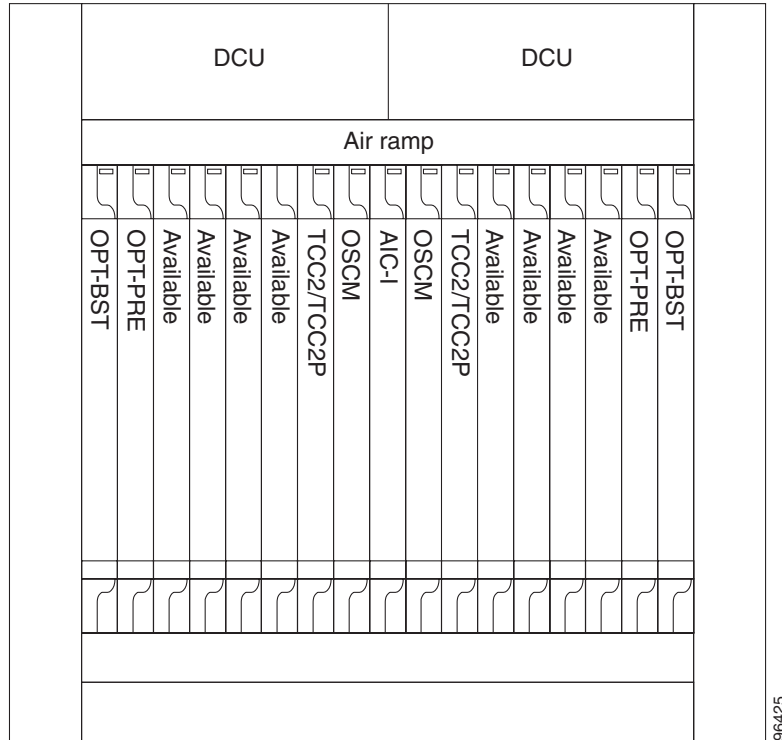

## 17.1.7 OSC Regeneration Node

The OSC regeneration node is added to the DWDM networks for two purposes:

- To electrically regenerate the OSC channel whenever the span links are 37 dB or longer and payload amplification and add/drop capabilities are not present. Cisco MetroPlanner places an OSC regeneration node in spans longer than 37 dB. 31 dB is the longest span between the OSC regeneration node and the next DWDM network site.
- To add data communications network (DCN) capability wherever needed within the network.

OSC regeneration nodes require two OSC-CSM cards, as shown in [Figure 17-13](#).

**Figure 17-13 OSC Regeneration Line Node Configuration Example**

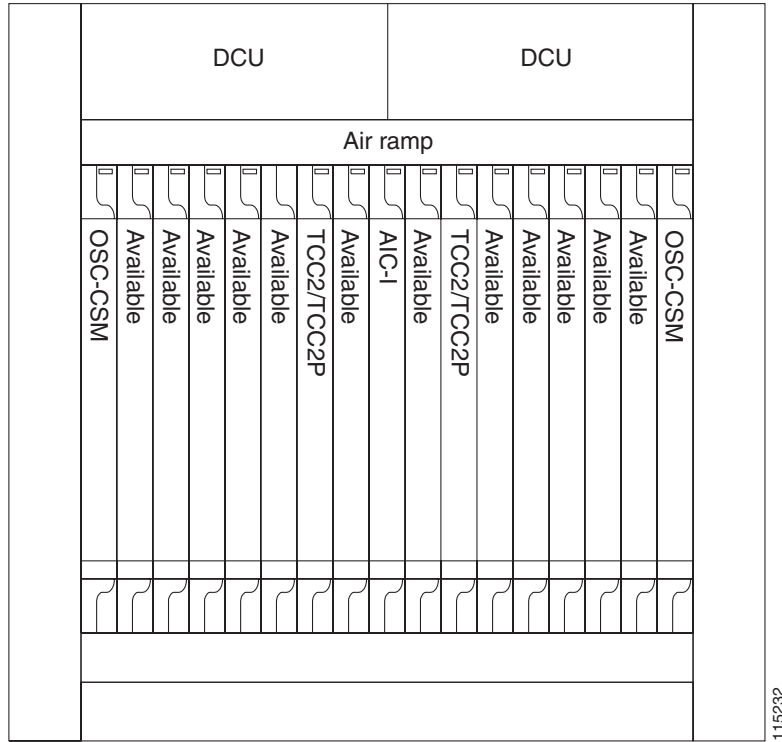
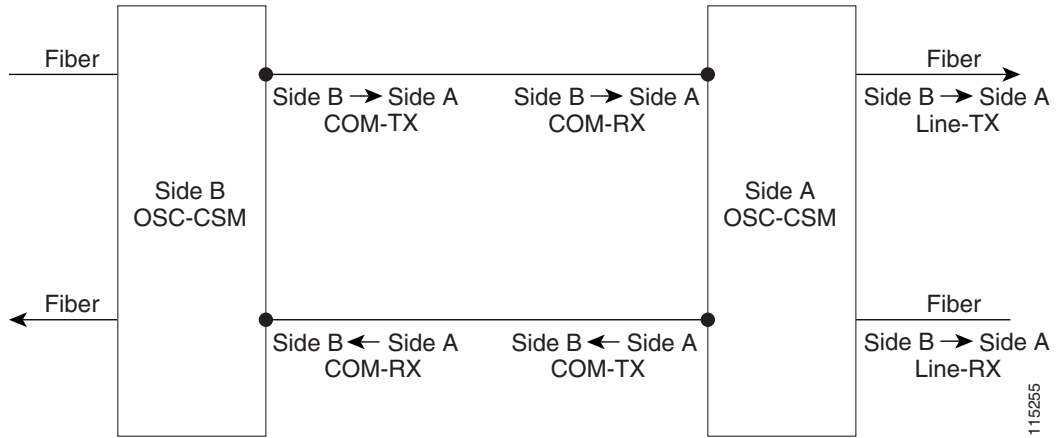

Figure 17-14 shows the OSC regeneration line node OSC signal flow.

**Figure 17-14 OSC Regeneration Line Node Flow**



## 17.2 DWDM and TDM Hybrid Node Types

The node type in a network configuration is determined by the type of card that is installed in an ONS 15454 hybrid node. The ONS 15454 supports the following hybrid DWDM and TDM node types: 1+1 protected flexible terminal, scalable terminal, hybrid terminal, hybrid OADM, hybrid line amplifier, and amplified TDM.

**Note**

---

The MetroPlanner tool creates a plan for amplifier placement and proper equipment for DWDM node configurations. Although TDM cards can be used with DWDM node configuration, the MetroPlanner tool does not create a plan for TDM card placement. MetroPlanner will support TDM configurations in a future release.

---

### 17.2.1 1+1 Protected Flexible Terminal Node

The 1+1 protected flexible terminal node is a single ONS 15454 node equipped with a series of OADM cards acting as a hub node configuration. This configuration uses a single hub or OADM node connected directly to the far-end hub or OADM node through four fiber links. This node type is used in a ring configured with two point-to-point links. The advantage of the 1+1 protected flexible terminal node configuration is that it provides path redundancy for 1+1 protected TDM networks (two transmit paths and two receive paths) using half of the DWDM equipment that is usually required. In the following example ([Figure 17-15](#)), one node transmits traffic to the other node on both east and west sides of the ring for protection purposes. If the fiber is damaged on one side of the ring, traffic still arrives safely through fiber on the other side of the ring.

**Figure 17-15 Double Terminal Protection Configuration**

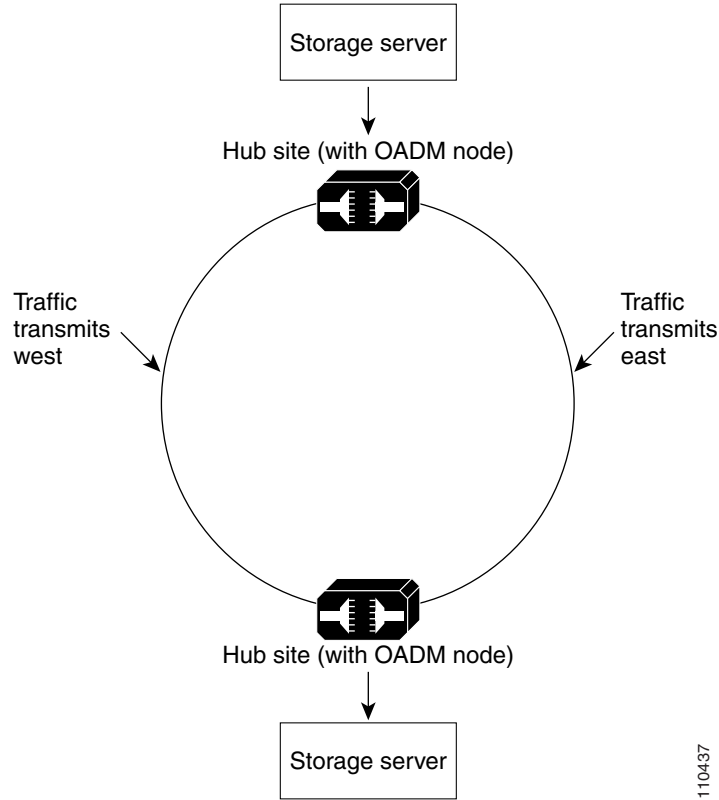

Figure 17-16 shows a 1+1 protected single-span link with hub nodes. This node type cannot be used in a hybrid configuration.

Figure 17-16 1+1 Protected Single-Span Link with Hub Nodes

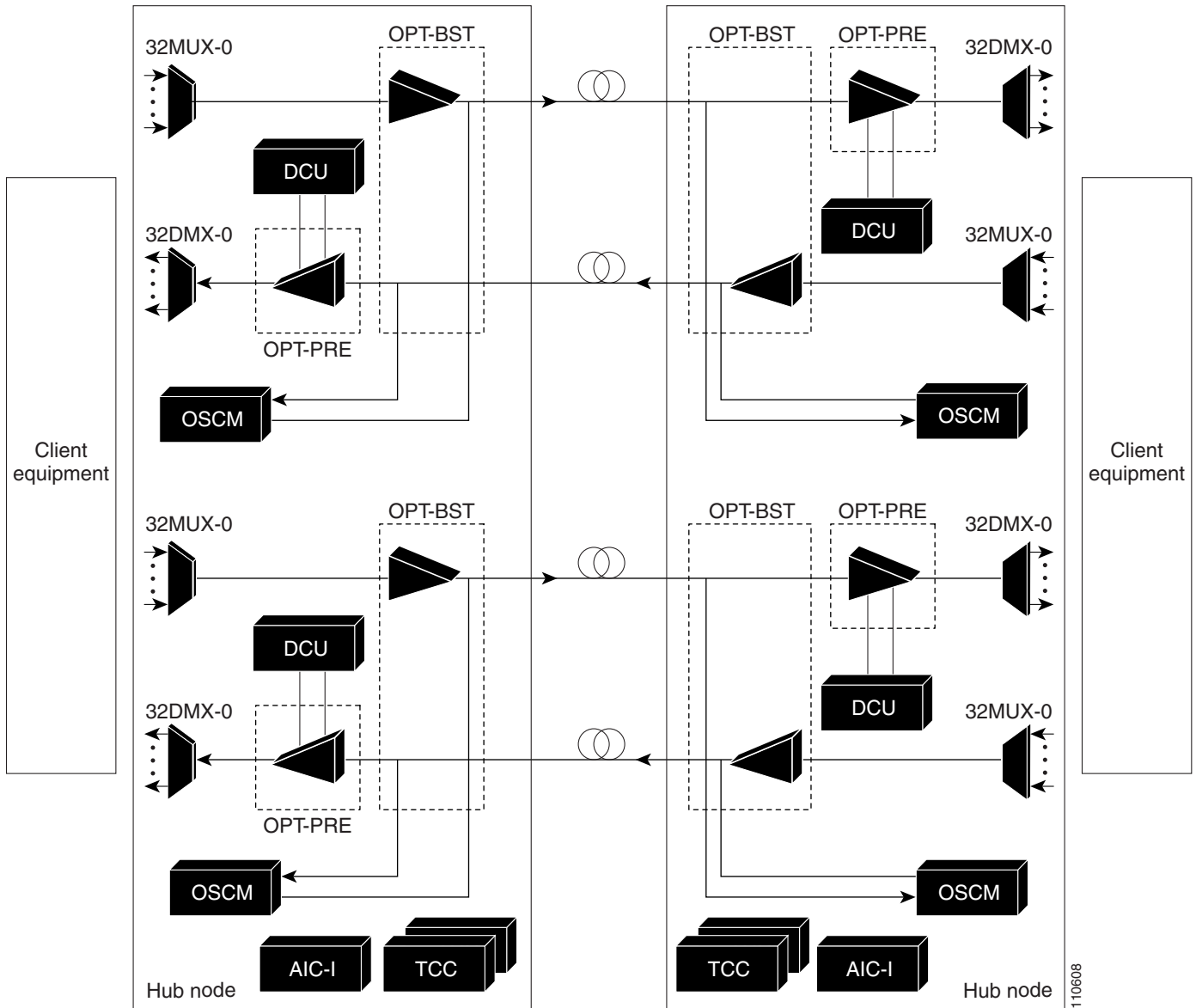
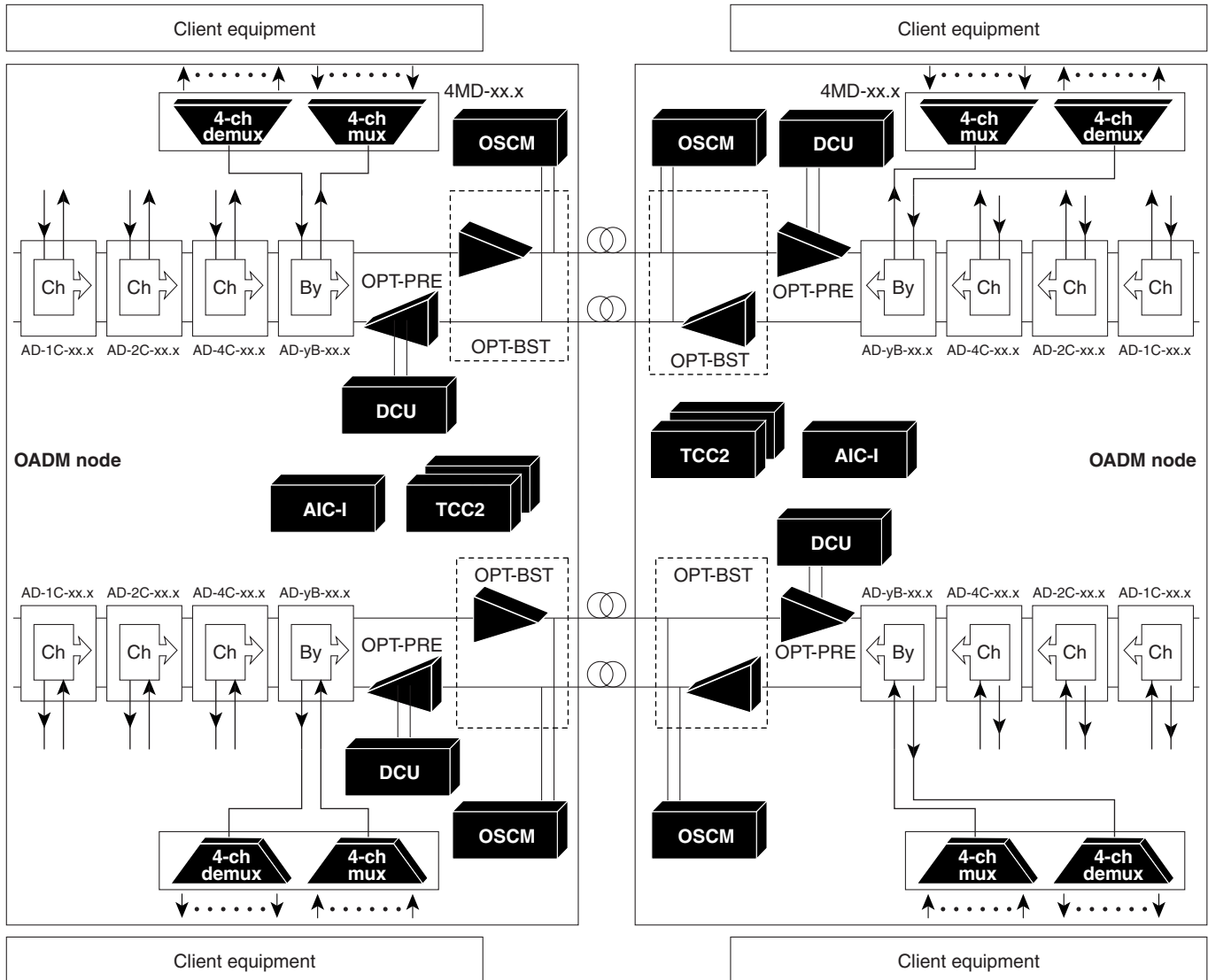

Figure 17-17 shows a 1+1 protected single-span link with active OADM nodes. This node type can be used in a hybrid configuration.

Figure 17-17 1+1 Protected Single-Span Link with Active OADM Nodes



110609

Figure 17-18 shows a 1+1 protected single-span link with passive OADM nodes. This node type can be used in a hybrid configuration.

Figure 17-18 1+1 Protected Single-Span Link with Passive OADM Nodes

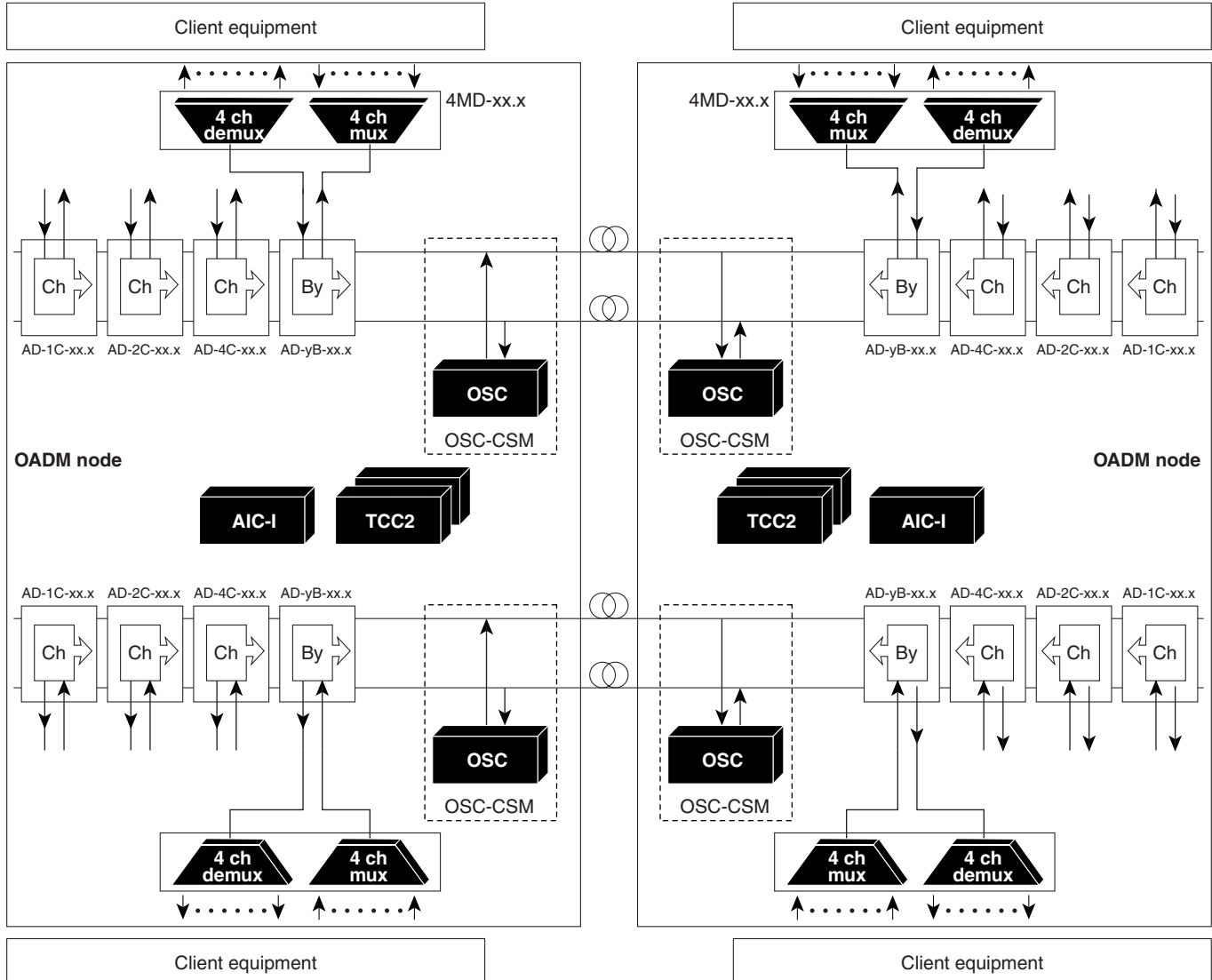

110610

## 17.2.2 Scalable Terminal Node

The scalable terminal node is a single ONS 15454 node equipped with a series of OADM cards and amplifier cards. This node type is more cost effective if a maximum of 16 channels are used (Table 17-1). This node type does not support a terminal configuration exceeding 16 channels because the 32-channel terminal site is more cost effective for 17 channels and beyond.



### Note

The dash (—) in the following table below means not applicable.

**Table 17-1** Typical AD Configurations for Scalable Terminal Nodes

Number of Channels	Terminal Configuration	
	Option 1	Option 2
1	AD-1C-xx.x	—
2	AD-2C-xx.x	—
3	AD-4C-xx.x	AD-1B-xx.x + 4MD-xx.x
4	AD-4C-xx.x	AD-1B-xx.x + 4MD-xx.x
5	AD-1C-xx.x + AD-4C-xx.x	AD-1C-xx.x + AD-1B-xx.x + 4MD-xx.x
6	AD-2C-xx.x + AD-4C-xx.x	AD-2C-xx.x + AD-1B-xx.x + 4MD-xx.x
7	2 x AD-4C-xx.x	2 x (AD-1B-xx.x + 4MD-xx.x)
8	2 x AD-4C-xx.x	2 x (AD-1B-xx.x + 4MD-xx.x)
9	AD-1C-xx.x + (2 x AD-4C-xx.x)	AD-1C-xx.x + 2 x (AD-1B-xx.x + 4MD-xx.x)
10	AD-2C-xx.x + (2 x AD-4C-xx.x)	AD-2C-xx.x + 2 x (AD-1B-xx.x + 4MD-xx.x)
11	3 x AD-4C-xx.x	AD-4B-xx.x + (3 x 4MD-xx.x)
12	3 x AD-4C-xx.x	AD-4B-xx.x + (3 x 4MD-xx.x)
13	AD-4B-xx.x + (3 x 4MD-xx.x) + AD-1C-xx.x	AD-4B-xx.x + (4 x 4MD-xx.x)
14	AD-4B-xx.x + (3 x 4MD-xx.x) + AD-1C-xx.x	AD-4B-xx.x + (4 x 4MD-xx.x)
15	—	AD-4B-xx.x + (4 x 4MD-xx.x)
16	—	AD-4B-xx.x + (4 x 4MD-xx.x)

The OADM cards that can be used in this type of node are: AD-1C-xx.x, AD-2C-xx.x, AD-4C-xx.x, and AD-1B-xx.x. You can also use AD-4B-xx.x and up to four 4MD-xx.x cards. The OPT-PRE and/or OPT-BST amplifiers can be used. The OPT-PRE or OPT-BST configuration depends on the node loss and the span loss. When the OPT-BST is not installed, the OSC-CSM must be used instead of the OSCM card. [Figure 17-19 on page 17-20](#) shows a channel flow example of a scalable terminal node configuration.

Figure 17-19 Scalable Terminal Channel Flow Example

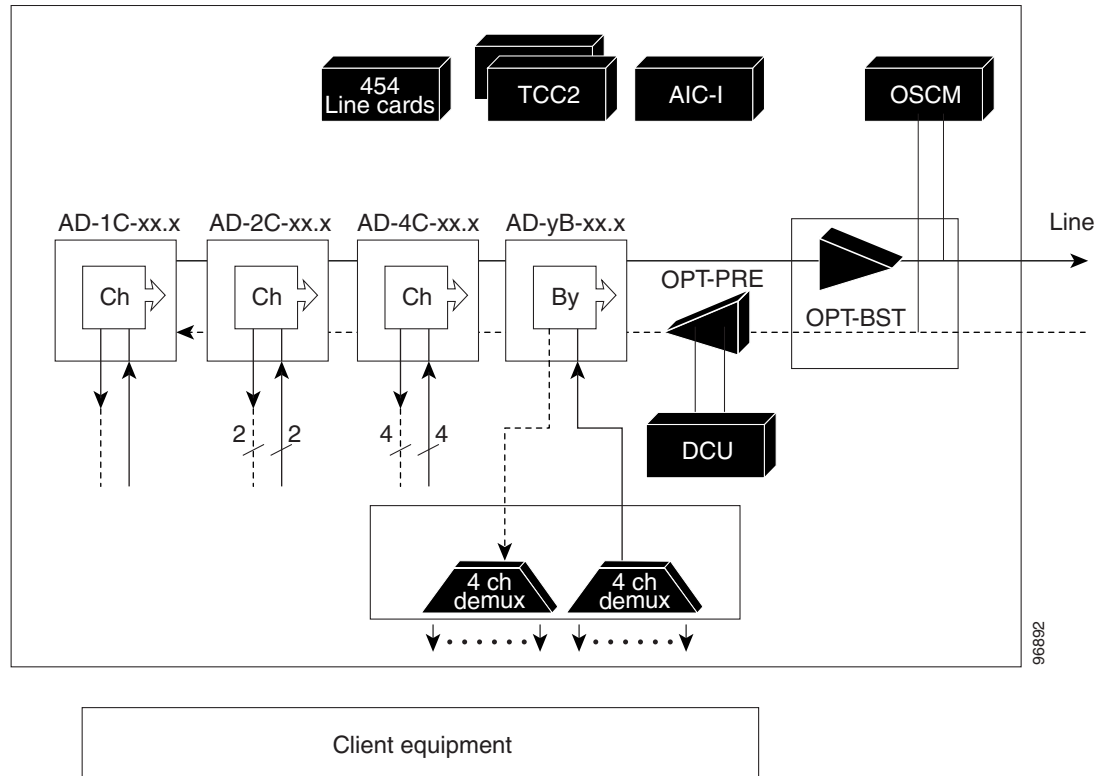

A scalable terminal node can be created by using band and/or channel OADM filter cards. This node type is the most flexible of all node types because the OADM filter cards can be configured to accommodate node traffic. If the node does not contain amplifiers, it is considered a passive hybrid terminal node.

Figure 17-20 shows an example of a scalable terminal node configuration. This node type can be used without add or drop cards.







Figure 17-23 Hybrid Amplified OADM Example

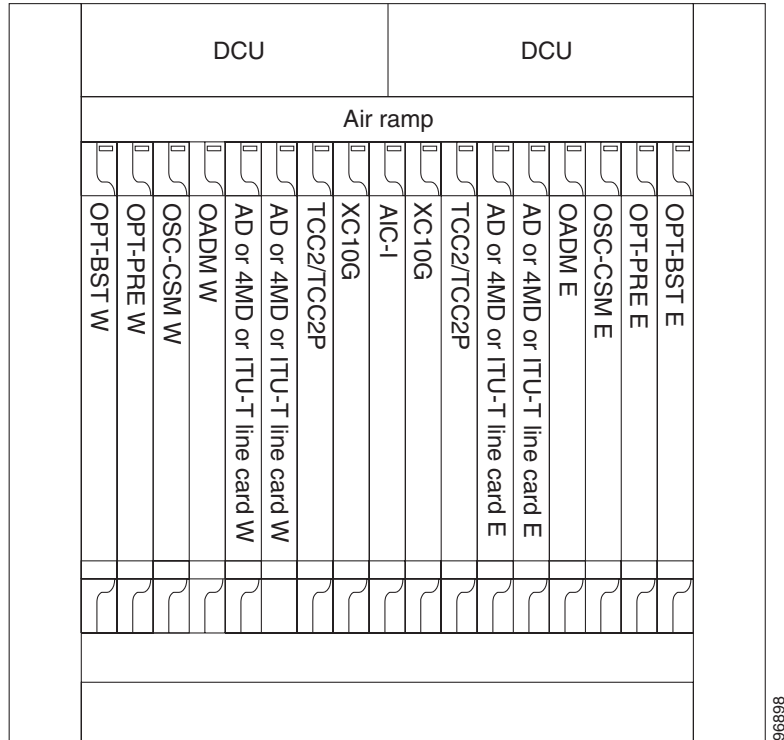

## 17.2.5 Hybrid Line Amplifier Node

A hybrid line amplifier node is a single ONS 15454 node with open slots for both TDM and DWDM cards. [Figure 17-24](#) shows an example of a hybrid line amplifier node configuration. [Figure 17-25 on page 17-26](#) shows a channel flow example of a hybrid line node configuration. Since this node contains both TDM and DWDM rings, both TDM and DWDM rings should be terminated even if no interactions are present between them.



### Note

For DWDM applications, if the OPT-BST is not installed within the node, the OSC-CSM card must be used instead of the OSCM card.

Figure 17-24 Hybrid Line Amplifier Example

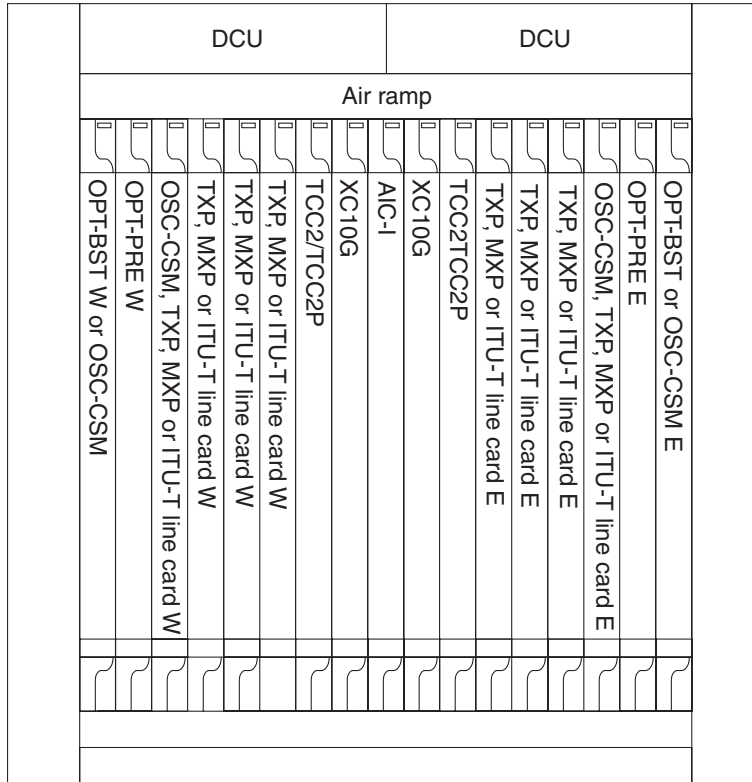

110436

Figure 17-25 Hybrid Line Amplifier Channel Flow Example

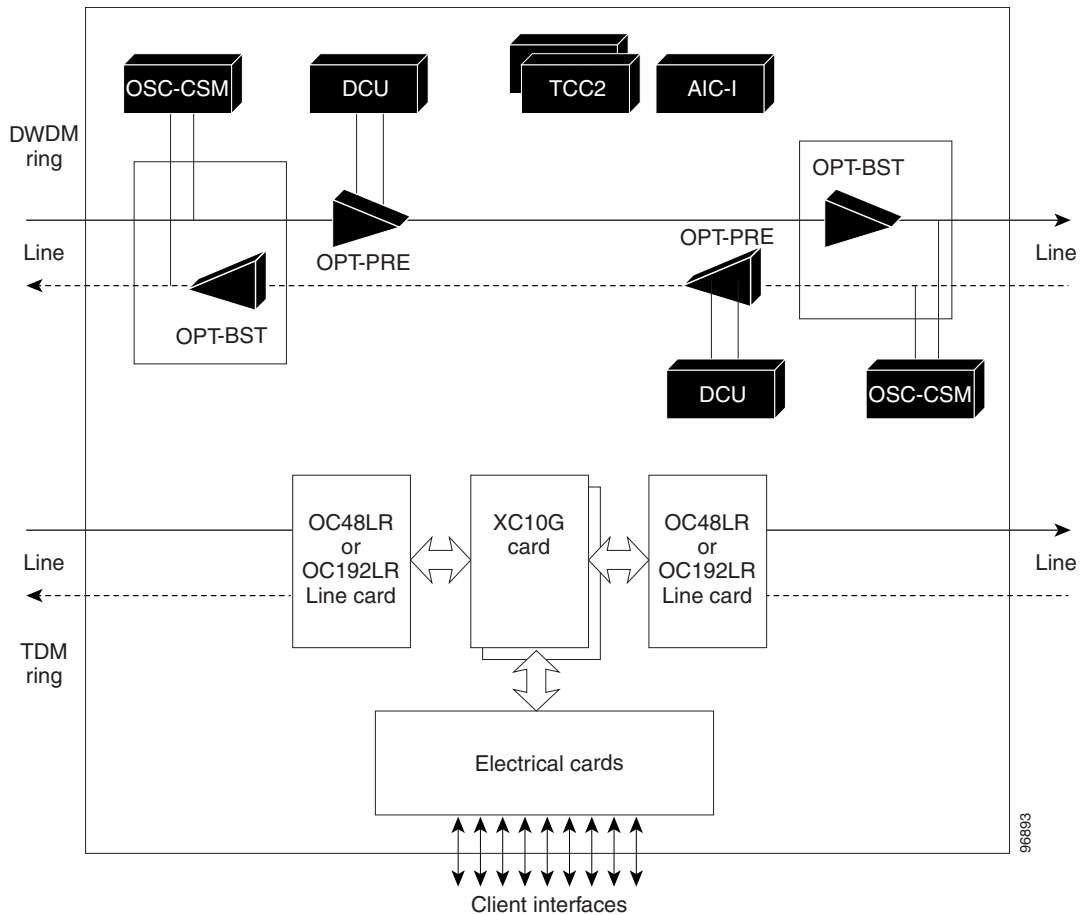

A hybrid line node is another example of the hybrid line amplifier OADM node. A hybrid line node is single ONS 15454 node equipped with OPT-PRE amplifiers, OPT-BST amplifiers, and TCC2/TCC2P cards for each line direction. Both types of amplifiers can be used or just one type of amplifier. Attenuators might also be required between each preamplifier and booster amplifier to match the optical input power value and to maintain the amplifier gain tilt value. TDM cards can be installed in any available slot. Review the plan produced by MetroPlanner to determine slot availability.

## 17.2.6 Amplified TDM Node

An amplified TDM node is a single ONS 15454 node that increases the span length between two ONS 15454 nodes that contain TDM cards and optical amplifiers. There are three possible installation configurations for an amplified TDM node. Scenario 1 uses client cards and OPT-BST amplifiers. Scenario 2 uses client cards, OPT-BST amplifiers, OPT-PRE amplifiers, and FlexLayer filters. Scenario 3 uses client cards, OPT-BST amplifiers, OPT-PRE amplifiers, AD-1C-xx.x cards, and OSC-CSM cards.

The client cards that can be used in an amplified TDM node are: TXP\_MR\_10G, MXP\_2.5G\_10G, TXP\_MR\_2.5G, TXPP\_MR\_2.5G, OC-192 LR/STM 64 ITU 15xx.xx, and OC-48 ELR/STM 16 EH 100 GHz.

Figure 17-26 shows the first amplified TDM node scenario with an OPT-BST amplifier.



Figure 17-28 Amplified TDM Example with FlexLayer Filters

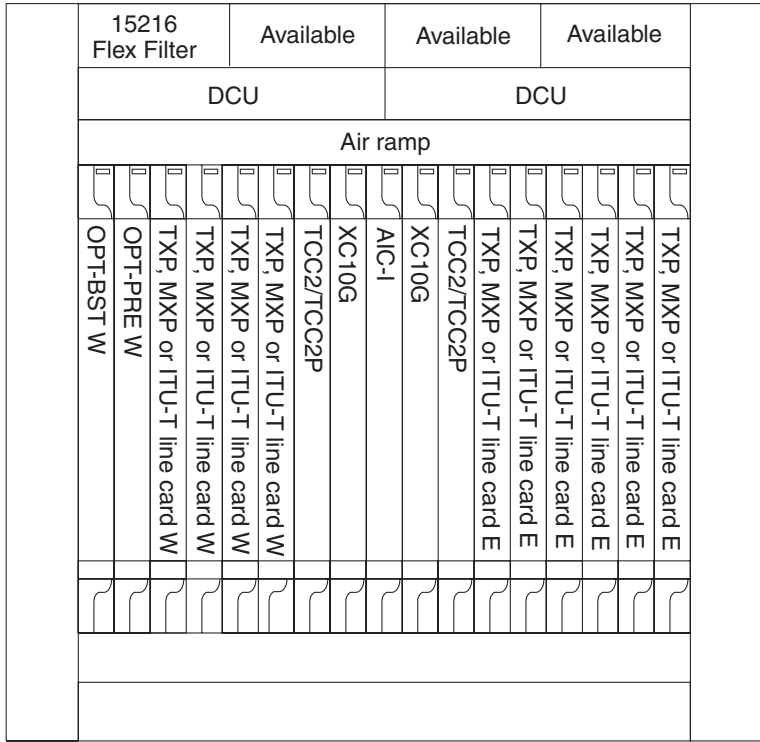

Figure 17-29 shows the second amplified TDM node channel flow configuration scenario with client cards, OPT-BST amplifiers, OPT-PRE amplifiers, and FlexLayer filters.

Figure 17-29 Amplified TDM Channel Flow Example With FlexLayer Filters

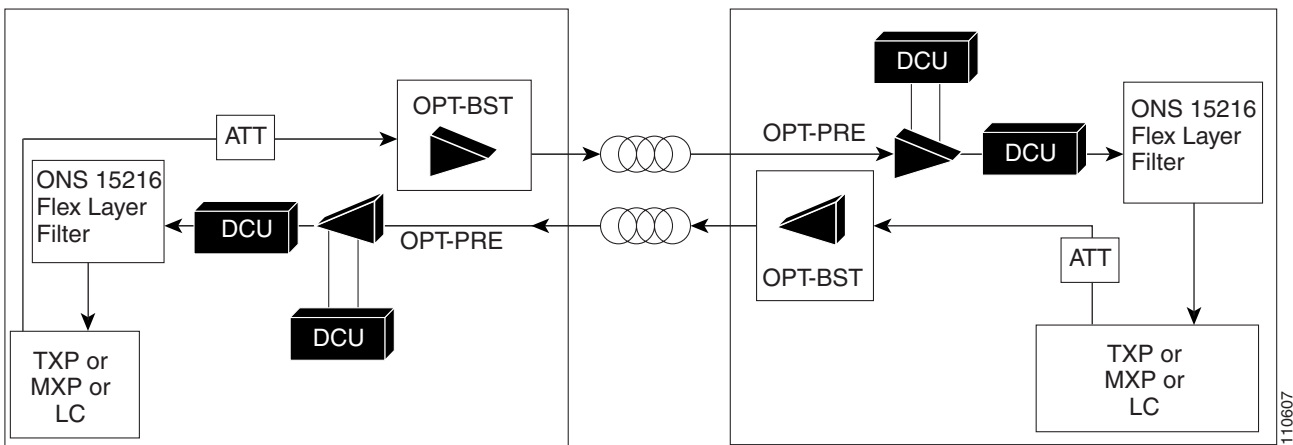
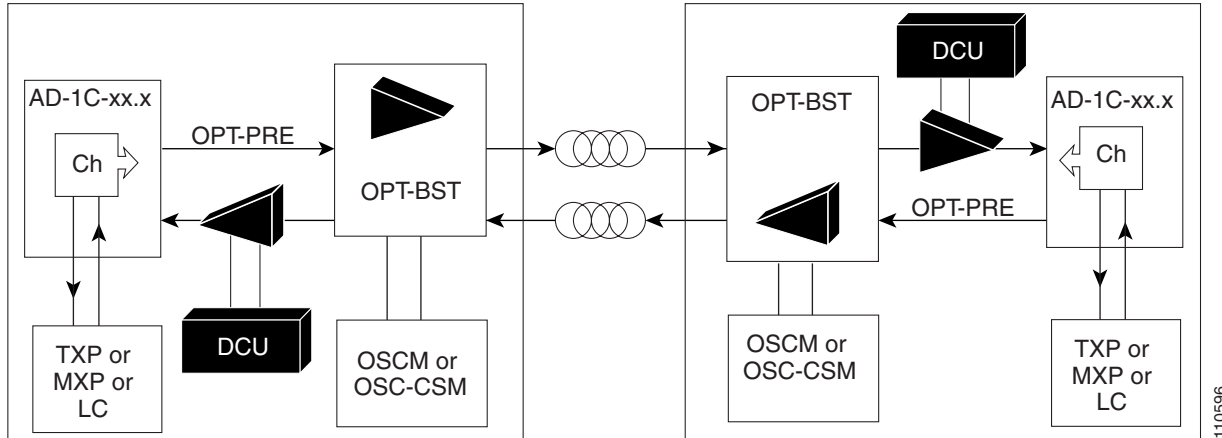

Figure 17-30 shows the third amplified TDM channel flow configuration scenario with client cards, OPT-BST amplifiers, OPT-PRE amplifiers, AD-1C-xx.x cards, and OSC-CSM cards.

Figure 17-30 Amplified TDM Channel Flow Example With Amplifiers, AD-1C-xx.x Cards, and OSC-CSM Cards



## 17.3 Automatic Node Setup

Automatic node setup (ANS) is a TCC2/TCC2P function that adjusts values of the VOAs on the DWDM channel paths to equalize the per-channel power at the amplifier input. This power equalization means that at launch, all the channels have the same amplifier power level, independent from the input signal on the client interface and independent from the path crossed by the signal inside the node. This equalization is needed for two reasons:

- Every path introduces a different penalty on the signal that crosses it.
- Client interfaces add their signal to the ONS 15454 DWDM ring with different power levels.

To support ANS, the integrated VOAs and photodiodes are provided in the following ONS 15454 DWDM cards:

- OADM band cards (AD-xB-xx.x) express and drop path
- OADM channel cards (AD-xC-xx.x) express and add path
- 4-Channel Terminal Multiplexer/Demultiplexer (4MD-xx.x) input port
- 32-Channel Terminal Multiplexer (32MUX-O) input port
- 32-Channel Wavelength Selective Switch (32WSS) input port
- 32-Channel Terminal Demultiplexer (32DMX-O and 32DMX) output port

Optical power is equalized by regulating the VOAs. Based on the expected per-channel power, ANS automatically calculates the VOA values by:

- Reconstructing the different channels paths
- Retrieving the path insertion loss (stored in each DWDM transmission element)

VOAs operate in one of three working modes:

- Automatic VOA Shutdown—In this mode, the VOA is set at maximum attenuation value. Automatic VOA shutdown mode is set when the channel is not provisioned to ensure system reliability in the event that power is accidentally inserted.

- **Constant Attenuation Value**—In this mode, the VOA is regulated to a constant attenuation independent from the value of the input signal. Constant attenuation value mode is set on the following VOAs:
  - OADM band card VOAs on express and drop paths (as operating mode)
  - OADM channel card VOAs during power insertion startup
  - The multiplexer/demultiplexer card VOAs during power insertion startup
- **Constant Power Value**—In this mode, the VOA values are automatically regulated to keep a constant output power when changes occur to the input power signal. This working condition is set on OADM channel card VOAs as “operating” and on 32MUX-O, 32WSS, 32DMX-O, and 32DMX card VOAs as “operating mode.”

In the normal operating mode, OADM band card VOAs are set to a constant attenuation, while OADM channel card VOAs are set to a constant power. ANS requires the following VOA provisioning parameters to be specified:

- Target attenuation (OADM band card VOA and OADM channel card startup)
- Target power (channel VOA)

To allow you to modify ANS values based on your DWDM deployment, provisioning parameters are divided into two contributions:

- Reference Contribution (read only)—Set by ANS.
- Calibration Contribution (read and write)—Set by user.

The ANS equalization algorithm requires the following knowledge of the DWDM transmission element layout:

- The order in which the DWDM elements are connected together on the express paths
- Channels that are dropped and added
- Channels or bands that have been configured as passthrough

ANS assumes that every DWDM port has a line direction parameter that is either west to east (W-E) or east to west (E-W). ANS automatically configures the mandatory optical connections according to following main rules:

- Cards equipped in Slots 1 to 6 have a drop section facing west.
- Cards equipped in Slots 12 to 17 have a drop section facing east.
- Contiguous cards are cascaded on the express path.
- 4MD-xx.x and AD-xB-xx.x are always optically coupled.
- A 4MD-xx.x absence forces an optical passthrough connection.
- Transmit (Tx) ports are always connected to receive (Rx) ports.

Optical patch cords are passive devices that are not autodiscovered by ANS. However, optical patch cords are used to build the alarm correlation graph. From CTC or TL1 you can:

- Calculate the default connections on the NE.
- Retrieve the list of existing connections.
- Retrieve the list of free ports.
- Create new connections or modify existing ones.
- Launch ANS.

After you launch ANS, the following status are provided for each ANS parameter:

- Success - Changed—The parameter setpoint was recalculated successfully.
- Success - Unchanged—The parameter setpoint did not need recalculation.
- Not Applicable—The parameter setpoint does not apply to this node type.
- Fail - Out of Range—The calculated setpoint is outside the expected range.
- Fail - Port in IS State—The parameter could not be calculated because the port is in-service.

Optical connections are identified by the two termination points, each with an assigned slot and port. ANS checks that a new connection is feasible (according to embedded connection rules) and returns a denied message in the case of a violation.

ANS requires provisioning of the expected wavelength. When provisioning the expected wavelength, the following rules apply:

- The card name is generically characterized by the card family, and not the particular wavelengths supported (for example, AD-2C for all 2-channel OADMs).
- At the provisioning layer, you can provision a generic card for a specific slot using CTC or TL1.
- Wavelength assignment is done at the port level.
- An equipment mismatch alarm is raised when a mismatch between the identified and provisioned value occurs. The default value for the provisioned attribute is AUTO.

## 17.3.1 Automatic Node Setup Parameters

All ONS 15454 ANS parameters are calculated by Cisco MetroPlanner for nodes configured for metro core networks. (Parameters must be configured manually for metro access nodes.) Cisco MetroPlanner exports the calculated parameters to an ASCII file called “NE Update.” In CTC, you can import the NE Update file to automatically provision the node. [Table 17-2](#) shows ANS parameters arranged in east and west, transmit and receive groups.

Table 17-2 ANS Parameters

Direction	ANS Parameters
West Side - Receive	<ul style="list-style-type: none"> <li>• West Side Rx Max Expected Span Loss</li> <li>• West Side Rx Min Expected Span Loss</li> <li>• West Side Rx Amplifier Working Mode</li> <li>• West Side Rx Amplifier Ch Power</li> <li>• West Side Rx Amplifier Gain</li> <li>• West Side Rx Amplifier Tilt</li> <li>• West Side OSC LOS Threshold</li> <li>• West Side Channel LOS Threshold</li> <li>• West Side Rx Amplifier Input Power Fail Th</li> <li>• West Side Add and Drop Stage Input Power</li> <li>• West Side Add and Drop Stage Drop Power</li> <li>• West Side Add and Drop Stage Band (i) Drop Power (i = 1 through 8)</li> <li>• West Side Add and Drop Stage Channel (i) Drop Power (i = 1 through 32)</li> </ul>
East Side - Receive	<ul style="list-style-type: none"> <li>• East Side Rx Max Expected Span Loss</li> <li>• East Side Rx Min Expected Span Loss</li> <li>• East Side Rx Amplifier Working Mode</li> <li>• East Side Rx Amplifier Ch Power</li> <li>• East Side Rx Amplifier Gain</li> <li>• East Side Rx Amplifier Tilt</li> <li>• East Side OSC LOS Threshold</li> <li>• East Side Channel LOS Threshold</li> <li>• East Side Rx Amplifier Input Power Fail Th</li> <li>• East Side Add and Drop Stage Input Power</li> <li>• East Side Add and Drop Stage Drop Power</li> <li>• East Side Add and Drop Stage Band (i) Drop Power (i = 1 through 8)</li> <li>• East Side Add and Drop Stage Channel (i) Drop Power (i = 1 through 32)</li> </ul>

Table 17-2 ANS Parameters (continued)

Direction	ANS Parameters
West Side - Transmit	<ul style="list-style-type: none"> <li>• West Side Tx Amplifier Working Mode</li> <li>• West Side Tx Amplifier Ch Power</li> <li>• West Side Tx Amplifier Gain</li> <li>• West Side Tx Amplifier Tilt</li> <li>• West Side Fiber Stage Input Threshold</li> <li>• West Side Add and Drop Stage Output Power</li> <li>• West Side Add and Drop Stage By-Pass Power</li> </ul>
East Side - Transmit	<ul style="list-style-type: none"> <li>• East Side Tx Amplifier Working Mode</li> <li>• East Side Tx Amplifier Ch Power</li> <li>• East Side Tx Amplifier Gain</li> <li>• East Side Tx Amplifier Tilt</li> <li>• East Side Fiber Stage Input Threshold</li> <li>• East Side Add and Drop Stage Output Power</li> <li>• East Side Add and Drop Stage By-Pass Power</li> </ul>

## 17.3.2 View and Provision ANS Parameters

All ANS parameters can be viewed and provisioned from the node view Provisioning > WDM-ANS > Provisioning subtab, shown in [Figure 17-31](#). The WDM-ANS > Provisioning > Provisioning subtab presents the parameters in the following tree view:

```

root
+/- East
  • +/- Receiving
    - +/- Amplifier
    - +/- Power
    - +/- Threshold
  • +/- Transmitting
    - +/- Amplifier
    - +/- Power
    - +/- Threshold
+/- West
  • +/- Receiving
    - +/- Amplifier
    - +/- Power
    - +/- Threshold
  • +/- Transmitting

```

## 17.3.2 View and Provision ANS Parameters

- +/- Amplifier
- +/- Power
- +/- Threshold

Figure 17-31 WDM-ANS Provisioning

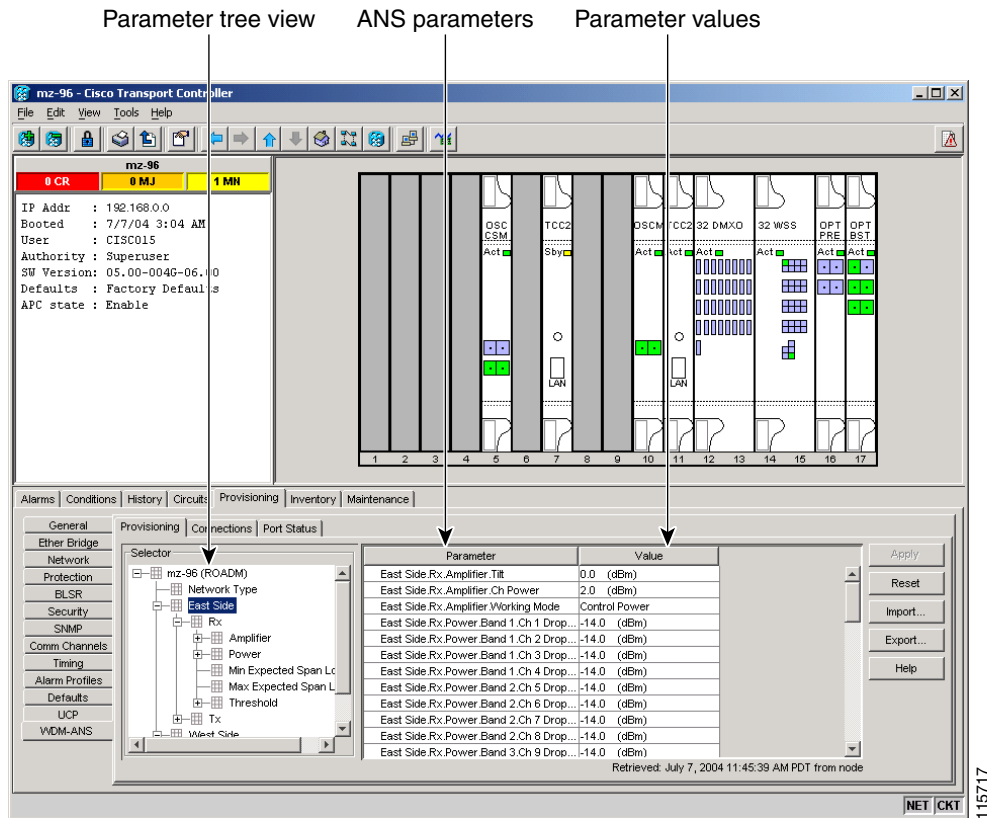

Table 17-3 shows the parameter IDs based on platform, line-direction, and functional group.

Table 17-3 ANS-WDM &gt; Provisioning Subtab Parameters

Tree Element	Parameters
root	Network Type (dwdm)
root +/- East +/- Receiving	East Side Rx Max Expected Span Loss East Side Rx Min Expected Span Loss
root +/- East +/- Receiving +/- Amplifier	East Side Rx Amplifier Working Mode East Side Rx Amplifier Ch Power East Side Rx Amplifier Gain East Side Rx Amplifier Tilt

**Table 17-3 ANS-WDM > Provisioning Subtab Parameters (continued)**

<b>Tree Element</b>	<b>Parameters</b>
root +/- East +/- Receiving +/- Power	East Side Add and Drop Input Power East Side Add and Drop Drop Power East Side Band n Drop Power (n = 1-8) East Side Channel n Drop Power East (n = 1-32)
root +/- East +/- Receiving +/- Thresholds	East Side OSC LOS Threshold East Side Channel LOS Threshold East Side Rx Amplifier In Power Fail Th
root +/- East +/- Transmitting +/- Amplifier	East Side Tx Amplifier Working Mode East Side Tx Amplifier Ch Power East Side Tx Amplifier Gain East Side Tx Amplifier Tilt
root +/- East +/- Transmitting +/- Power	East Side Add and Drop Output Power East Side Add and Drop By-Pass Power
root +/- East +/- Transmitting +/- Thresholds	East Side Fiber Stage Input Threshold
root +/- West +/- Receiving	West Side Rx Max Expected Span Loss West Side Rx Min Expected Span Loss
root +/- West +/- Receiving +/- Amplifier	West Side Rx Amplifier Working Mode West Side Rx Amplifier Ch Power West Side Rx Amplifier Gain West Side Rx Amplifier Tilt
root +/- West +/- Receiving +/- Power	West Side Add and Drop Input Power West Side Add and Drop Drop Power West Side Band n Drop Power (n = 1-8) West Side Channel n Drop Power (n = 1-32)
root +/- West +/- Receiving +/- Thresholds	West Side OSC LOS Threshold West Side Channel LOS Threshold West Side Rx Amplifier In Power Fail Th
root +/- West +/- Transmitting +/- Amplifier	West Side Tx Amplifier Working Mode West Side Tx Amplifier Ch Power West Side Tx Amplifier Gain West Side Tx Amplifier Tilt
root +/- East +/- Transmitting +/- Power	West Side Add and Drop Output Power West Side Add and Drop By-Pass Power
root +/- West +/- Transmitting +/- Thresholds	West Side Fiber Stage Input Threshold

The ANS parameters that appear in the WDM-ANS > Provisioning subtab depend on the node type. Table 17-4 shows the DWDM node types and their ANS parameters.

**Table 17-4 ANS Parameters By Node Type**

Node Type	Parameter Group	Parameters
Hub	Network	Network Type
	Span Loss	East and West Expected Span Loss
	Amplifier Tx	East and West Side Transmit Amplifier Working Mode East and West Side Transmit Amplifier Channel Power East and West Side Transmit Amplifier Gain East and West Side Transmit Amplifier Tilt
	Amplifier Rx	East and West Side Receive Amplifier Working Mode East and West Side Receive Amplifier Channel Power East and West Side Receive Amplifier Gain East and West Side Receive Amplifier Tilt
	Thresholds Tx	East and West Side Fiber Stage Input Threshold
	Thresholds Rx	East and West Side Osc Los Threshold East and West Side Channel Los Threshold East and West Side Receive Amplifier Input Power Fail
	Power	East and West Side Add and Drop Input Power East and West Side Add and Drop Output Power East and West Side Add and Drop By-Pass Power East and West Side Channel (n) Drop Power

Table 17-4 ANS Parameters By Node Type (continued)

Node Type	Parameter Group	Parameters
Terminal	Network	Network Type
	Span Loss	East or West Expected Span Loss
	Amplifier Tx	East or West Side Transmit Amplifier Working Mode East or West Side Transmit Amplifier Channel Power East or West Side Transmit Amplifier Gain East or West Side Transmit Amplifier Tilt
	Amplifier Rx	East or West Side Receive Amplifier Working Mode East or West Side Receive Amplifier Channel Power East or West Side Receive Amplifier Gain East or West Side Receive Amplifier Tilt
	Thresholds Tx	East or West Side Fiber Stage Input Threshold
	Thresholds Rx	East or West Side Osc Los Threshold East or West Side Channel Los Threshold East or West Side Receive Amplifier Input Power Fail
	Power	East or West Side Add and Drop Input Power East or West Side Add and Drop Output Power East or West Side Channel (n) Drop Power (n = 1-32)
Flexible Channel Count Terminal	Network	Network Type
	Span Loss	East and West Expected Span Loss
	Amplifier Tx	East and West Side Transmit Amplifier Working Mode East and West Side Transmit Amplifier Channel Power East and West Side Transmit Amplifier Gain East and West Side Transmit Amplifier Tilt
	Amplifier Rx	East and West Side Receive Amplifier Working Mode East and West Side Receive Amplifier Channel Power East and West Side Receive Amplifier Gain East and West Side Receive Amplifier Tilt
	Thresholds Tx	East and West Side Fiber Stage Input Threshold
	Thresholds Rx	East and West Side Osc Los Threshold East and West Side Channel Los Threshold East and West Side Receive Amplifier Input Power Fail
	Power	East and West Side Add and Drop Input Power East and West Side Add and Drop Output Power East and West Side Band (n) Drop Power (n = 1-8)

Table 17-4 ANS Parameters By Node Type (continued)

Node Type	Parameter Group	Parameters
OADM	Network	Network Type
	Span Loss	East and West Expected Span Loss
	Amplifier Tx	East and West Side Transmit Amplifier Working Mode East and West Side Transmit Amplifier Channel Power East and West Side Transmit Amplifier Gain East and West Side Transmit Amplifier Tilt
	Amplifier Rx	East and West Side Receive Amplifier Working Mode East and West Side Receive Amplifier Channel Power East and West Side Receive Amplifier Gain East and West Side Receive Amplifier Tilt
	Thresholds Tx	East and West Side Fiber Stage Input Threshold
	Thresholds Rx	East and West Side Osc Los Threshold East and West Side Channel Los Threshold East and West Side Receive Amplifier Input Power Fail
	Power	East and West Side Add and Drop Input Power East and West Side Add and Drop Output Power East and West Side Band (n) Drop Power (n = 1-8)
Line Amplifier	Network	Network Type
	Span Loss	East and West Expected Span Loss
	Amplifier Tx	East and West Side Transmit Amplifier Working Mode East and West Side Transmit Amplifier Channel Power East and West Side Transmit Amplifier Gain East and West Side Transmit Amplifier Tilt
	Amplifier Rx	East and West Side Receive Amplifier Working Mode East and West Side Receive Amplifier Channel Power East and West Side Receive Amplifier Gain East and West Side Receive Amplifier Tilt
	Thresholds Tx	East and West Side Fiber Stage Input Threshold
	Thresholds Rx	East and West Side Osc Los Threshold East and West Side Channel Los Threshold East and West Side Receive Amplifier Input Power Fail

**Table 17-4 ANS Parameters By Node Type (continued)**

Node Type	Parameter Group	Parameters
ROADM	Network	Network Type
	Span Loss	East and West Expected Span Loss
	Amplifier Tx	East and West Side Transmit Amplifier Working Mode East and West Side Transmit Amplifier Channel Power East and West Side Transmit Amplifier Gain East and West Side Transmit Amplifier Tilt
	Amplifier Rx	East and West Side Receive Amplifier Working Mode East and West Side Receive Amplifier Channel Power East and West Side Receive Amplifier Gain East and West Side Receive Amplifier Tilt
	Thresholds Tx	East and West Side Fiber Stage Input Threshold
	Thresholds Rx	East and West Side Osc Los Threshold East and West Side Channel Los Threshold East and West Side Receive Amplifier Input Power Fail
	Power	East and West Side Add and Drop Input Power (if 32DMX East/West is installed) East and West Side Add and Drop Output Power East and West Side Add and Drop Drop Power (if 32DMX East/West is installed) East and West Side Channel (n) Drop Power (if 32DMX-O East/West is installed)

Table 17-5 shows the following information for all ONS 15454 ANS parameters:

- Min—Minimum value in decibels.
- Max—Maximum value in decibels.
- Def—Default value in decibels. Other defaults include MC (metro core), CG (control gain), U (unknown).
- Group—Group(s) to which the parameter belongs: ES (east side), WS (west side), Rx (receive), Tx (transmit), Amp (amplifier), P (power), DB (drop band), DC (drop channel), A (attenuation), Th (threshold).
- Network Type—Parameter network type: MC (metro core), MA (metro access), ND (not DWDM)
- Optical Type—Parameter optical type: TS (32 channel terminal), FC (flexible channel count terminal), O (OADM), H (hub), LS (line amplifier), R (ROADM), U (unknown)

**Table 17-5 ANS Parameters Summary**

General Name	Min	Max	Def	Group	Network Type	Optical Type
Network Type	–	–	MC	Root	MC, MA, ND	U, TS, FC, O, H, LS, R
West Side Rx Max Expected Span Loss	0	60	60	WS, Rx	MC, MA	TS, FC, O, H, LS, R

Table 17-5 ANS Parameters Summary (continued)

General Name	Min	Max	Def	Group	Network Type	Optical Type
East Side Rx Max Expected Span Loss	0	60	60	ES, Rx	MC, MA	TS, FC, O, H, LS, R
West Side Rx Min Expected Span Loss	0	60	60	WS, Rx	MC, MA	TS, FC, O, H, LS, R
East Side Rx Min Expected Span Loss	0	60	60	ES, Rx	MC, MA	TS, FC, O, H, LS, R
West Side Tx Amplifier Working Mode	–	–	CG	WS, Tx, Amp	MC, MA, ND	TS, FC, O, H, LS, R
East Side Tx Amplifier Working Mode	–	–	CG	ES, Rx	MC, MA	TS, FC, O, H, LS, R
West Side Rx Amplifier Working Mode	–	–	CG	WS, Tx, Amp	MC, MA, ND	TS, FC, O, H, LS, R
East Side Rx Amplifier Working Mode	–	–	CG	ES, Rx	MC, MA	TS, FC, O, H, LS, R
West Side Tx Amplifier Ch Power	–10	17	2	WS, Tx, Amp	MC, MA, ND	TS, FC, O, H, LS, R
East Side Tx Amplifier Ch Power	–10	17	2	WS, Tx, Amp	MC, MA, ND	TS, FC, O, H, LS, R
West Side Rx Amplifier Ch Power	–10	17	2	WS, Tx, Amp	MC, MA, ND	TS, FC, O, H, LS, R
East Side Rx Amplifier Ch Power	–10	17	2	WS, Tx, Amp	MC, MA, ND	TS, FC, O, H, LS, R
West Side Tx Amplifier Gain	0	30	0	WS, Tx, Amp	MA	TS, FC, O, H, LS, R
East Side Tx Amplifier Gain	0	30	0	WS, Tx, Amp	MA	TS, FC, O, H, LS, R
West Side Rx Amplifier Gain	0	30	0	WS, Tx, Amp	MA	TS, FC, O, H, LS, R
East Side Rx Amplifier Gain	0	30	0	WS, Tx, Amp	MA	TS, FC, O, H, LS, R
West Side Tx Amplifier Tilt	0	30	0	WS, Tx, Amp	MC, MA	TS, FC, O, H, LS, R
East Side Tx Amplifier Tilt	0	30	0	WS, Tx, Amp	MC, MA	TS, FC, O, H, LS, R
West Side Rx Amplifier Tilt	0	30	0	WS, Rx, Amp	MC, MA	TS, FC, O, H, LS, R
East Side Rx Amplifier Tilt	0	30	0	WS, Rx, Amp	MC, MA	TS, FC, O, H, LS, R
West Side OSC LOS Threshold	–50	30	U	WS, Rx, Th	MC, MA	TS, FC, O, H, LS, R
East Side OSC LOS Threshold	–50	30	U	WS, Rx, Th	MC, MA	TS, FC, O, H, LS, R
West Side Channel LOS Threshold	–50	30	U	WS, Rx, Th	MC, MA	TS, FC, O, H, LS, R
East Side Channel LOS Threshold	–50	30	U	ES, Rx, Th	MC, MA, ND	TS, FC, O, H, LS, R
West Side Fiber State Input Threshold	–50	30	U	WS, Tx, Th	MC, MA, ND	TS, FC, O, H, LS, R
East Side Fiber State Input Threshold	–50	30	U	ES, Tx, Th	MC, MA, ND	TS, FC, O, H, LS, R
West Side Add and Drop Output Power	–50	30	–14	WS, Tx, P	MC	TS, FC, O, H, R
East Side Add and Drop Output Power	–50	30	–14	ES, Tx, P	MC	TS, FC, O, H, R
West Side Add and Drop Input Power	–50	30	–14	WS, Rx, P	MC	TS, FC, O, H, R
East Side Add and Drop Input Power	–50	30	–14	ES, Rx, P	MC	TS, FC, O, H, R
West Side Add and Drop By-Pass Power	–50	30	–14	WS, Tx, P	MC	H
East Side Add and Drop By-Pass Power	–50	30	–14	ES, Tx, P	MC	H
West Side Add and Drop Drop Power	–50	30	–14	WS, Tx, P	MC	R
East Side Add and Drop Drop Power	–50	30	–14	ES, Tx, P	MC	R
West Side Band 1...8 Drop Power	–50	30	–14	WS, Rx, P, DB	MC	FC, O
East Side Band 1...8 Drop Power	–50	30	–14	ES, Rx, P, DB	MC	FC, O

**Table 17-5** ANS Parameters Summary (continued)

General Name	Min	Max	Def	Group	Network Type	Optical Type
West Side Channel 1...32 Drop Power	-50	30	-14	WS, Rx, P, DC, B1	MC, MA	TS, H, R
East Side Channel 1...32 Drop Power	-50	30	-14	ES, Rx, P, DC, B1	MC, MA	TS, H, R

