



## Network Reference

---

This chapter explains the ONS 15454 dense wavelength division multiplexing (DWDM) network applications and topologies. The chapter also provides network-level optical performance references.



**Note**

---

Unless otherwise specified, “ONS 15454” refers to both ANSI and ETSI shelf assemblies.

---

Chapter topics include:

- [17.1 Network Applications, page 17-1](#)
- [17.2 Network Topologies, page 17-2](#)
- [17.3 Optical Performance, page 17-6](#)
- [17.4 Automatic Power Control, page 17-17](#)
- [17.5 ROADM Power Equalization Monitoring, page 17-22](#)
- [17.6 Span Loss Verification, page 17-23](#)
- [17.7 Network Optical Safety—Automatic Laser Shutdown, page 17-24](#)
- [17.8 Network-Level Gain—Tilt Management of Optical Amplifiers, page 17-28](#)

## 17.1 Network Applications

Cisco ONS 15454s can be provisioned for metro access and metro core DWDM network applications. Metro access networks are 60 km or less in size. Channels are not equalized and dispersion compensation is not applied. Metro access networks have few spans and very low span loss, so the signal link budget is the limiting factor for performance. Metro core networks can be up to 400 km in size. The channel power is equalized and dispersion compensation is applied. Metro core networks often include multiple spans and amplifiers, so the optical signal-to-noise ratio (OSNR) is the limiting factor for channel performance in metro core networks.

Within DWDM networks, the ONS 15454 uses a communications protocol, called node services protocol (NSP), to communicate with other nodes. NSP automatically updates nodes whenever a change in the network occurs. Each ONS 15454 DWDM node can:

- Identify other ONS 15454 DWDM nodes in the network.
- Identify the different types of DWDM networks.
- Identify when the DWDM network is complete and when it is incomplete.

# 17.2 Network Topologies

The ONS 15454 DWDM network topologies include hubbed, multihubbed, and meshed rings, and linear and single-span networks.

## 17.2.1 Hubbed Rings

In the hubbed ring topology (Figure 17-1), a hub node terminates all the DWDM channels. A channel can be provisioned to support protected traffic between the hub node and any node in the ring. Both working and protected traffic use the same wavelength on both sides of the ring. Protected traffic can also be provisioned between any pair of optical add/drop multiplexing (OADM) nodes, except that either the working or the protected path must be regenerated in the hub node.

Protected traffic saturates a channel in a hubbed ring, that is, no channel reuse is possible. However, the same channel can be reused in different sections of the ring by provisioning unprotected multihop traffic. From a transmission point of view, this network topology is similar to two bidirectional point-to-point links with OADM nodes.

For more information about hub nodes, see the “16.1.1 Hub Node” section on page 16-1.

Figure 17-1 Hubbed Ring

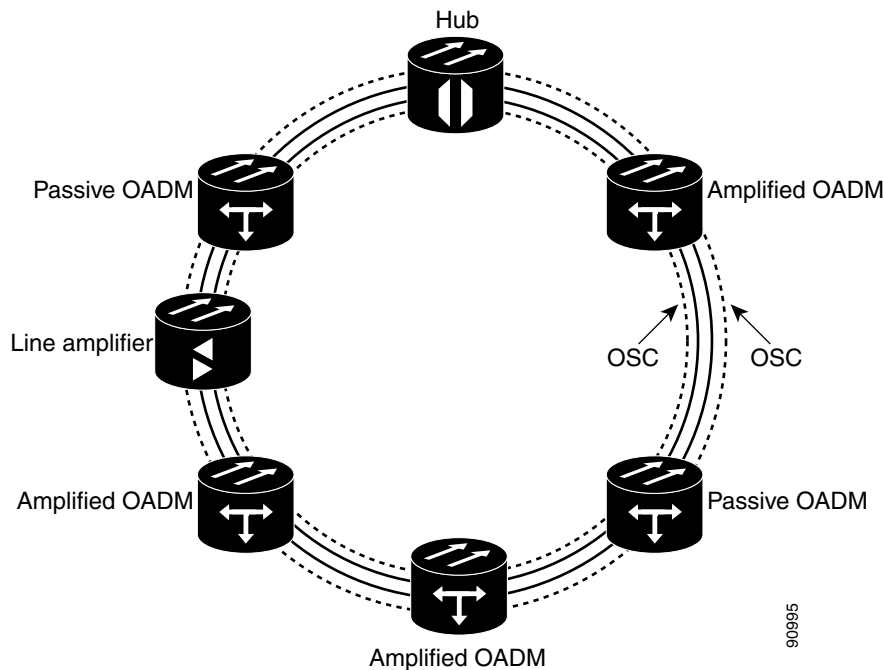

## 17.2.2 Multihubbed Rings

A multihubbed ring (Figure 17-2) is based on the hubbed ring topology, except that two or more hub nodes are added. Protected traffic can only be established between the two hub nodes. Protected traffic can be provisioned between a hub node and any OADM node only if the allocated wavelength channel

is regenerated through the other hub node. Multihop traffic can be provisioned on this ring. From a transmission point of view, this network topology is similar to two or more point-to-point links with OADM nodes.

**Figure 17-2 Multihubbed Ring**

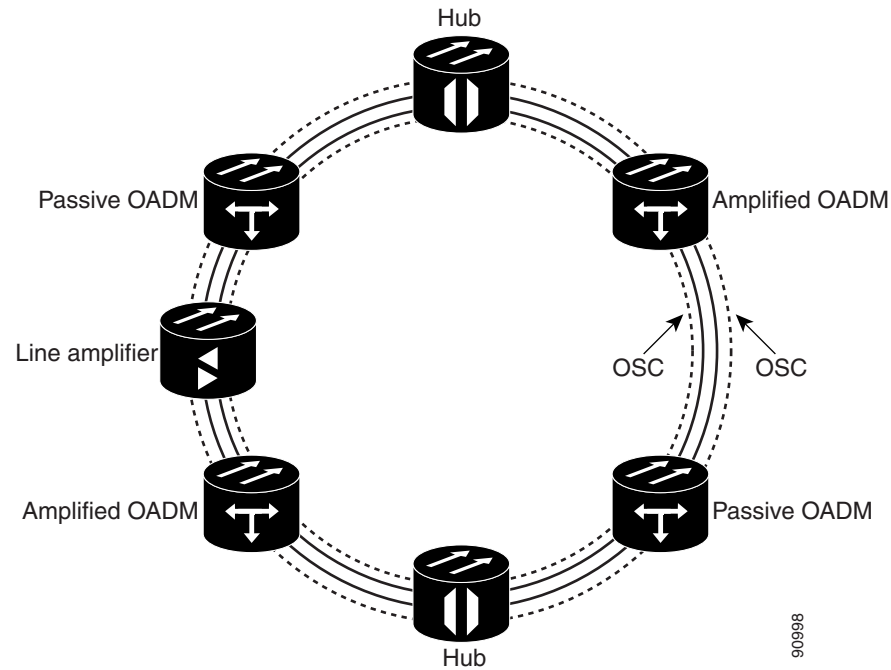

## 17.2.3 Any-to-Any Rings

The any-to-any ring topology (Figure 17-3) contains only reconfigurable OADM (ROADM) nodes, or ROADM nodes with Optical Service Channel (OSC) regeneration or amplifier nodes. This topology potentially allows you to route every wavelength from any source to any destination node inside the network.

See the “16.1.4 ROADM Node” section on page 16-8 for more information.

Figure 17-3 Any-to-Any Ring

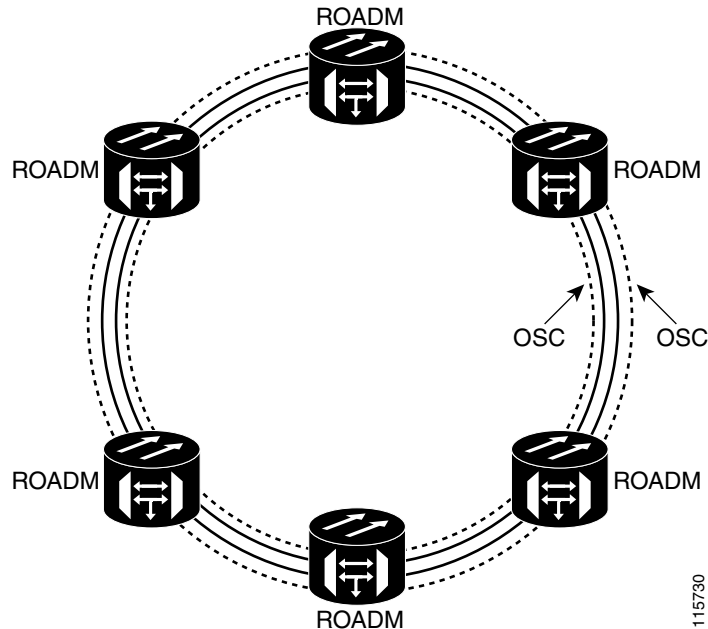

## 17.2.4 Meshed Rings

The meshed ring topology (Figure 17-4) does not use hubbed nodes; only amplified and passive OADM nodes are present. Protected traffic can be provisioned between any two nodes; however, the selected channel cannot be reused in the ring. Unprotected multihop traffic can be provisioned in the ring. A meshed ring must be designed to prevent amplified spontaneous emission (ASE) lasing. This is done by configuring a particular node as an anti-ASE node. An anti-ASE node can be created in two ways:

- Equip an OADM node with 32MUX-O cards and 32DMX-O cards. This solution is adopted when the total number of wavelengths deployed in the ring is higher than ten. OADM nodes equipped with 32MUX-O cards and 32DMX-O cards are called full OADM nodes.
- When the total number of wavelengths deployed in the ring is lower than ten, the anti-ASE node is configured by using an OADM node where all the channels that are not terminated in the node are configured as “optical pass-through.” In other words, no channels in the anti-ASE node can travel through the express path of the OADM node.

For more information about OADM nodes, see the “16.1.3 OADM Node” section on page 16-4. For more information about anti-ASE nodes, see the “16.1.5 Anti-ASE Node” section on page 16-10.

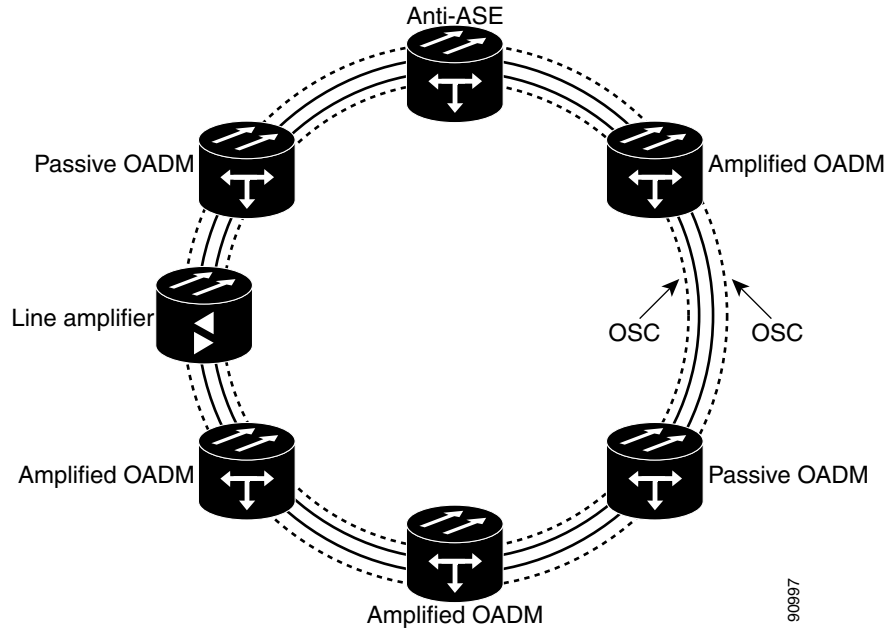
**Figure 17-4** *Meshed Ring*

## 17.2.5 Linear Configurations

Linear configurations are characterized by the use of two terminal nodes (west and east). The terminal nodes can be equipped with a 32MUX-O card and a 32DMX-O card, or a 32WSS card with a 32DMX or 32DMX-O card. OADM or line amplifier nodes can be installed between the two terminal nodes. Only unprotected traffic can be provisioned in a linear configuration. [Figure 17-5](#) shows five ONS 15454 nodes in a linear configuration with an amplified and a passive OADM node.

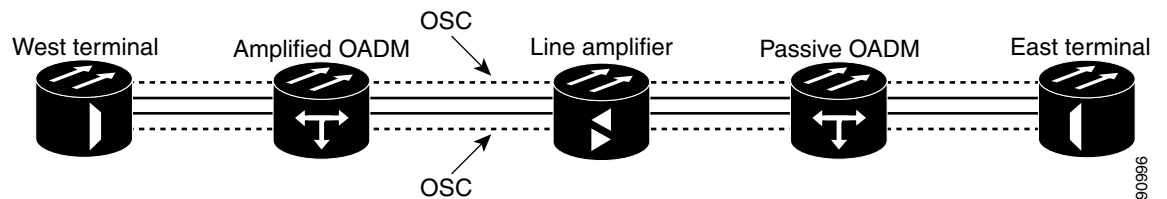
**Figure 17-5** *Linear Configuration with an OADM Node*

[Figure 17-6](#) shows five ONS 15454 nodes in a linear configuration without an OADM node.

See the [“16.1.2 Terminal Node”](#) section on page 16-3 for more information.

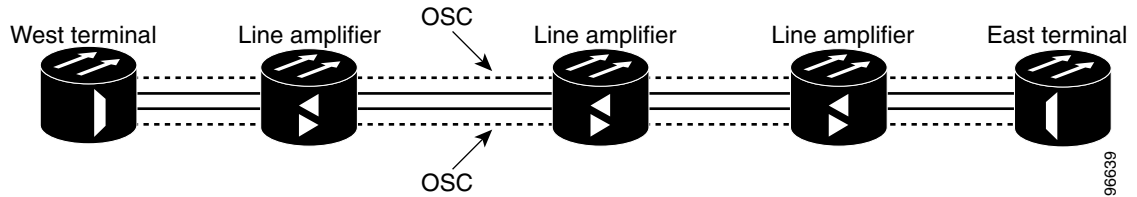
**Figure 17-6** Linear Configuration without an OADM Node

## 17.2.6 Single-Span Link

Single-span link is a type of linear configuration characterized by a single-span link with pre-amplification and post-amplification. A single-span link is also characterized by the use of two terminal nodes (west and east). The terminal nodes are usually equipped with a 32MUX-O card and a 32DMX-O card. However, a 32WSS card and a 32DMX or a 32DMX-O card can be installed. Software R4.7 and later also supports single-span links with AD-4C-xx.x cards. Only unprotected traffic can be provisioned on a single-span link.

Figure 17-7 shows ONS 15454s in a single-span link. Eight channels are carried on one span. Single-span link losses apply to OC-192 LR ITU cards. The optical performance values are valid assuming that the sum of the OADM passive node insertion losses and the span losses does not exceed 35 dB.

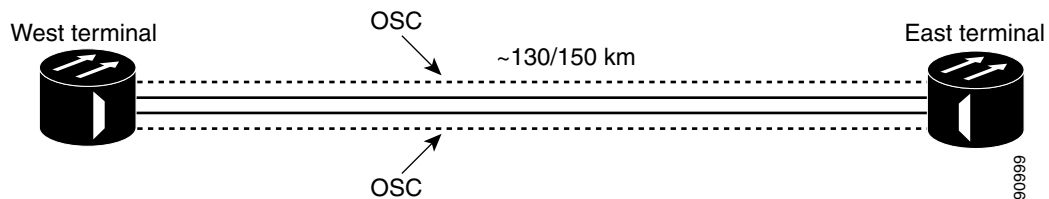
**Figure 17-7** Single-Span Link

## 17.3 Optical Performance

This section provides optical performance information for ONS 15454 DWDM networks. The performance data is a general guideline based upon the network topology, node type, client cards, fiber type, number of spans, and number of channels. The maximum number of nodes that can be in an ONS 15454 DWDM network is 16. The DWDM topologies and node types that are supported are shown in Table 17-1.

**Table 17-1 Supported Topologies and Node Types**

Number of Channels	Fiber	Topologies	Node Type
32 channels	SMF-28 <sup>1</sup>	Ring	Hub
	E-LEAF <sup>2</sup>	Linear	Active OADM
	TW-RS <sup>3</sup>	Linear without OADM	Passive OADM Terminal Line OSC regeneration
16 channels	SMF-28	Ring	Hub
		Linear	Active OADM
		Linear without OADM	Passive OADM Terminal Line OSC regeneration
8 channels	SMF-28	Linear without OADM	Terminal Line

1. SMF-28 = single-mode fiber 28
2. E-LEAF = enhanced large effective area fiber
3. TW-RS = TrueWave reduced slope fiber

DWDM client cards are grouped into nine classes, shown in [Table 17-2](#). Span loss estimates are based on the number of spans in the network and the client card class. Some cards belong to more than one class depending on whether forward error correction (FEC) is enabled and on the payload data type provisioned for the card.

**Table 17-2 ONS 15454 Client Card Classes**

Class	Rate	Clients
A	10 Gbps	TXP_2.5G_10G—FEC enabled TXP_2.5G_10E—FEC enabled TXP_MR_10G—FEC enabled TXP_MR_10E—FEC enabled
B	10 Gbps	TXP_2.5G_10G—FEC not enabled TXP_MR_10G—FEC not enabled
C	10 Gbps	OC-192 LR ITU TXP_2.5G_10E—FEC not enabled
D	2.5 Gbps	TXP_MR_2.5G—FEC enabled TXPP_MR_2.5G—FEC enabled

**Table 17-2 ONS 15454 Client Card Classes (continued)**

Class	Rate	Clients
E	2.5 Gbps	TXP_MR_2.5G—3R payload data type; FEC disabled TXPP_MR_2.5G—3R payload data type; FEC disabled MXP_MR_2.5G MXPP_MR_2.5G
F	2.5 Gbps	TXP_MR_2.5G—2R payload data type TXPP_MR_2.5G—2R payload data type
G	2.5 Gbps	OC-48 ELR ITU
H	2.5 Gbps	2/4 port Gigabit Ethernet Transponder (GBIC WDM 100 GHz)
I	10 Gbps	TXP_2.5G_10E—E-FEC <sup>1</sup> enabled TXP_MR_10E—E-FEC enabled

1. Forward error correction

## 17.3.1 Optical Performance for Rings and Linear Networks with OADM Nodes

The following tables provide optical performance estimates for open and closed ONS 15454 rings and linear networks with OADM nodes.

Table 17-3 shows the optical performance for 32-channel networks using SMF fiber. Span losses shown in the table assume:

- OADM nodes have a loss of 16 dB and equal span losses.
- The DCU loss is 9 dB.
- Optical Preamplifier (OPT-PRE) and Optical Booster (OPT-BST/OPT-BST-E) amplifiers are installed in all nodes.
- The OPT-PRE amplifier switches to control power whenever the span loss is higher than 27 dB.

See Table 17-2 for a list of cards in each class. A dash (—) indicates spans that are not supported.

**Table 17-3 Span Loss for 32-Channel Ring and Linear Networks with OADM Nodes Using SMF Fiber**

Number of Spans	10 Gbps				2.5 Gbps					
	Class A	Class B	Class C	Class I	Class D	Class E	Class F	Class G	Class H	Class J
1	35 dB	25 dB	25 dB	37 dB	37 dB	33 dB	30 dB	32 dB	34 dB	30 dB
2	29 dB	21 dB	20 dB	30 dB	31 dB	27 dB	25 dB	26 dB	28 dB	25 dB
3	26 dB	17 dB	15 dB	28 dB	29 dB	25 dB	23 dB	24 dB	26 dB	23 dB
4	24 dB	—	—	25 dB	26 dB	23 dB	20 dB	22 dB	24 dB	20 dB
5	23 dB	—	—	24 dB	25 dB	22 dB	16 dB	20 dB	23 dB	16 dB
6	21 dB	—	—	23 dB	24 dB	19 dB	—	17 dB	21 dB	—
7	20 <sup>1</sup> dB	—	—	22 dB	23 dB	16 dB	—	—	19 dB	—

1. 0.5 dB of OSNR impairment recovered by FEC margin @ BER > 10<sup>-6</sup>

Table 17-4 shows the optical performance for 16-channel networks using SMF fiber. Span loss values assume the following:

- OADM nodes have a loss of 16 dB and equal span losses.
- The DCU loss is 9 dB.
- All nodes have OPT-PRE and OPT-BST/OPT-BST-E amplifiers installed.
- The OPT-PRE amplifier switches to control power whenever the span loss is higher than 27 dB.

See Table 17-2 for a list of cards in each class. A dash (—) indicates the spans that are not supported.

**Table 17-4** Span Loss for 16-Channel Ring and Linear Networks with OADM Nodes Using SMF Fiber

Number of Spans	10 Gbps				2.5 Gbps					
	Class A	Class B	Class C	Class I	Class D	Class E	Class F	Class G	Class H	Class J
1	37 dB	29 dB	28 dB	37 dB	37 dB	36 dB	33 dB	35 dB	37 dB	33 dB
2	32 dB	24 dB	24 dB	34 dB	35 dB	31 dB	28 dB	30 dB	32 dB	28 dB
3	29 dB	22 dB	21 dB	31 dB	32 dB	28 dB	25 dB	27 dB	29 dB	25 dB
4	27 dB	19 dB	17 dB	29 dB	30 dB	26 dB	23 dB	25 dB	27 dB	23 dB
5	26 dB	—	—	27 dB	28 dB	24 dB	22 dB	24 dB	25 dB	22 dB
6	25 dB	—	—	26 dB	27 dB	23 dB	21 dB	23 dB	24 dB	21 dB
7	24 dB	—	—	25 dB	256dB	23 dB	19 dB	22 dB	23 dB	19 dB

Table 17-5 shows the optical performance for 32-channel networks using TW-RS fiber. Span loss values assume the following:

- OADM nodes have a loss of 16 dB and equal span losses.
- The DCU is 550 ps with 4 dB loss.
- All nodes have OPT-PRE and OPT-BST/OPT-BST-E amplifiers installed.
- The OPT-PRE amplifier switches to control power whenever the span loss is higher than 27 dB.

See Table 17-2 for a list of cards in each class. A dash (—) indicates the spans that are not supported.

**Table 17-5** Span Loss for 32-Channel Ring and Linear Networks with OADM Nodes Using TW-RS Fiber

Number of Spans	10 Gbps				2.5 Gbps					
	Class A	Class B	Class C	Class I	Class D	Class E	Class F	Class G	Class H	Class J
1	35 dB	25 dB	25 dB	37 dB	37 dB	33 dB	30 dB	32 dB	34 dB	30 dB
2	29 dB	21 dB	20 dB	31 dB	32 dB	28 dB	26 dB	27 dB	29 dB	26 dB
3	27 dB	17 dB	15 dB	29 dB	30 dB	26 dB	23 dB	25 dB	27 dB	23 dB
4	25 dB	—	—	27 dB	28 dB	23 dB	20 dB	22 dB	24 dB	20 dB
5	23 dB	—	—	26 dB	27 dB	22 dB	16 dB	20 dB	23 dB	16 dB
6	21 dB	—	—	24 dB	25 dB	19 dB	—	17 dB	21 dB	—
7	20 dB	—	—	22 dB	24 dB	16 dB	—	—	19 dB	—

Table 17-6 shows the optical performance for 32-channel networks using E-LEAF fiber. Span loss values assume the following:

- OADM nodes have a loss of 16 dB and equal span losses.
- The DCU is 550 ps with 4 dB loss.
- All nodes have OPT-PRE and OPT-BST/OPT-BST-E amplifiers installed.
- The OPT-PRE amplifier switches to control power whenever the span loss is higher than 27 dB.

See [Table 17-2](#) for a list of cards in each class. A dash (—) indicates the spans that are not supported.

**Table 17-6** Span Loss for 32-Channel Ring and Linear Networks with OADM Nodes Using E-LEAF Fiber

Number of Spans	10 Gbps				2.5 Gbps					
	Class A	Class B	Class C	Class I	Class D	Class E	Class F	Class G	Class H	Class J
1	35 dB	25 dB	25 dB	37 dB	37 dB	33 dB	30 dB	32 dB	34 dB	30 dB
2	29 dB	21 dB	20 dB	31 dB	32 dB	28 dB	26 dB	27 dB	29 dB	26 dB
3	27 dB	17 dB	15 dB	29 dB	30 dB	26 dB	23 dB	25 dB	27 dB	23 dB
4	24 dB	—	—	26 dB	28 dB	23 dB	20 dB	22 dB	24 dB	20 dB
5	22 dB	—	—	24 dB	27 dB	22 dB	16 dB	20 dB	23 dB	16 dB
6	20 dB	—	—	22 dB	25 dB	19 dB	—	17 dB	21 dB	—
7	17 dB	—	—	20 dB	24 dB	16 dB	—	—	19 dB	—

## 17.3.2 Optical Performance for Linear Networks Without OADM Nodes

The following tables list the reference optical performances for linear networks without OADM nodes. [Table 17-7](#) shows the optical performance for 32-channel linear networks using SMF fiber. Span loss values assume the following:

- No OADM nodes are installed and span losses are equal.
- The DCU loss is 9 dB.
- Only OPT-PRE amplifiers are installed.

See [Table 17-2](#) for a list of cards in each class. A dash (—) indicates the spans that are not supported.

**Table 17-7** Span Loss for 32-Channel Linear Networks without OADM Nodes Using SMF Fiber

Number of Spans	10 Gbps				2.5 Gbps					
	Class A	Class B	Class C	Class I	Class D	Class E	Class F	Class G	Class H	Class J
1	35 dB	25 dB	25 dB	37 dB	37 dB	33 dB	30 dB	32 dB	34 dB	30 dB
2	27 dB	20 dB	19 dB	29 dB	30 dB	26 dB	23 dB	25 dB	26 dB	23 dB
3	24 dB	17 dB	17 dB	25 dB	26 dB	23 dB	20 dB	22 dB	23 dB	20 dB
4	22 dB	15 dB	14 dB	23 dB	24 dB	21 dB	19 dB	20 dB	22 dB	19 dB
5	21 dB	—	—	22 dB	22 dB	20 dB	18 dB	19 dB	20 dB	18 dB
6	20 dB	—	—	21 dB	21 dB	19 dB	17 dB	18 dB	19 dB	17 dB
7	19 dB	—	—	20 dB	20 dB	18 dB	16 dB	18 dB	19 dB	16 dB

[Table 17-8](#) shows the optical performance for 32-channel linear networks using TW-RS fiber. Span loss values assume the following:

- No OADM nodes are installed and span losses are equal.
- The DCU is 550 ps with 4 dB loss.
- Only OPT-PRE amplifiers are installed.

See [Table 17-2](#) for a list of cards in each class. A dash (—) indicates the spans that are not supported.

**Table 17-8** *Span Loss for 32-Channel Linear Networks without OADM Nodes Using TW-RS Fiber*

Number of Spans	10 Gbps				2.5 Gbps					
	Class A	Class B	Class C	Class I	Class D	Class E	Class F	Class G	Class H	Class J
1	35 dB	25 dB	25 dB	37 dB	37 dB	33 dB	30 dB	32 dB	34 dB	30 dB
2	28 dB	20 dB	20 dB	30 dB	31 dB	27 dB	24 dB	26 dB	27 dB	24 dB
3	26 dB	18 dB	17 dB	27 dB	28 dB	24 dB	22 dB	23 dB	25 dB	22 dB
4	24 dB	15 dB	14 dB	25 dB	26 dB	23 dB	21 dB	22 dB	24 dB	20 dB
5	23 dB	—	—	24 dB	25 dB	22 dB	19 dB	21 dB	22 dB	19 dB
6	22 dB	—	—	23 dB	24 dB	20 dB	17 dB	19 dB	21 dB	17 dB
7	21 dB	—	—	23 dB	23 dB	19 dB	16 dB	18 dB	20 dB	16 dB

[Table 17-9](#) shows the optical performance for 32-channel linear networks using E-LEAF fiber. Span loss values assume the following:

- No OADM nodes are installed and span losses are equal.
- The DCU is 550 ps with 4 dB loss.
- Only OPT-PRE amplifiers are installed.

See [Table 17-2](#) for a list of cards in each class. A dash (—) indicates the spans that are not supported.

**Table 17-9** *Span Loss for 32-Channel Linear Networks without OADM Nodes Using E-LEAF Fiber*

Number of Spans	10 Gbps				2.5 Gbps					
	Class A	Class B	Class C	Class I	Class D	Class E	Class F	Class G	Class H	Class J
1	35 dB	25 dB	25 dB	37 dB	37 dB	33 dB	30 dB	32 dB	34 dB	30 dB
2	28 dB	20 dB	20 dB	30 dB	31 dB	27 dB	24 dB	26 dB	27 dB	24 dB
3	25 dB	18 dB	17 dB	27 dB	28 dB	24 dB	22 dB	23 dB	25 dB	22 dB
4	24 dB	15 dB	14 dB	25 dB	26 dB	23 dB	21 dB	22 dB	24 dB	20 dB
5	23 dB	—	—	24 dB	25 dB	22 dB	19 dB	21 dB	22 dB	19 dB
6	21 dB	—	—	22 dB	24 dB	20 dB	17 dB	19 dB	21 dB	17 dB
7	20 dB	—	—	21 dB	23 dB	19 dB	16 dB	18 dB	20 dB	16 dB

[Table 17-10](#) shows the optical performance for 16-channel linear networks using SMF fiber. Span loss values assume the following:

- No OADM nodes are installed and span losses are equal.
- The DCU loss is 9 dB.
- Only OPT-PRE amplifiers are installed.

- The minimum channel power is 4 dBm.
- Wavelengths are picked up without any restriction from Bands 4 and 5 (1542.14 to 1545.51 nm).

See [Table 17-2](#) for a list of cards in each class.

**Table 17-10** Span Loss for 16-Channel Linear Networks without OADM Nodes Using SMF Fiber

Number of Spans	10 Gbps				2.5 Gbps					
	Class A	Class B	Class C	Class I	Class D	Class E	Class F	Class G	Class H	Class J
1	37 dB	29 dB	28 dB	37 dB	37 dB	36 dB	33 dB	35 dB	37 dB	33 dB
2	32 dB	23 dB	23 dB	33 dB	34 dB	30 dB	27 dB	29 dB	31 dB	27 dB
3	28 dB	21 dB	20 dB	30 dB	30 dB	26 dB	24 dB	26 dB	27 dB	24 dB
4	26 dB	19 dB	18 dB	27 dB	28 dB	24 dB	22 dB	23 dB	25 dB	22 dB
5	24 dB	18 dB	17 dB	26 dB	26 dB	23 dB	21 dB	22 dB	24 dB	21 dB
6	23 dB	17 dB	17 dB	24 dB	25 dB	22 dB	20 dB	21 dB	22 dB	20 dB
7	22 dB	16 dB	15 dB	23 dB	24 dB	21 dB	19 dB	20 dB	21 dB	19 dB

[Table 17-11](#) shows the optical performance for 8-channel linear networks with 8 dBm per channel using SMF fiber. Span loss values assume the following:

- No OADM nodes are installed and span losses are equal.
- The DCU loss is 9 dB.
- Only OPT-PRE amplifiers are installed.

See [Table 17-2](#) for a list of cards in each class. A dash (—) indicates the spans that are not supported.

**Table 17-11** Span Loss for Eight-Channel Linear Networks without OADM Nodes Using SMF Fiber

Number of Spans	10 Gbps				2.5 Gbps					
	Class A	Class B	Class C	Class I	Class D	Class E	Class F	Class G	Class H	Class J
1	37 dB	31 dB	30 dB	37 dB	37 dB	37 dB	35 dB	37 dB	37 dB	35 dB
2	34 dB	26 dB	25 dB	34 dB	34 dB	32 dB	30 dB	31 dB	33 dB	30 dB
3	31 dB	23 dB	22 dB	33 dB	34 dB	29 dB	26 dB	28 dB	30 dB	26 dB
4	29 dB	—	—	30 dB	31 dB	27 dB	24 dB	26 dB	28 dB	24 dB
5	27 dB	—	—	29 dB	30 dB	26 dB	23 dB	25 dB	26 dB	23 dB
6	—	—	—	27 dB	—	—	—	—	—	—

### 17.3.3 Optical Performance for ROADM Rings and Linear Networks

The following tables list the reference optical performances for ROADM rings and linear networks.

[Table 17-12](#) shows the optical performance for 32-channel linear or ring networks using SMF fiber with only ROADM nodes installed. Span loss values assume the following:

- All nodes in the ring or linear network are ROADM with equal span losses.
- The DCU loss is 9 dB.
- OPT-PRE and OPT-BST/OPT-BST-E amplifiers are installed.

See [Table 17-2](#) for a list of cards in each class. A dash (—) indicates the spans that are not supported.

**Table 17-12** Span Loss for 32-Channel Linear or Ring Networks with all ROADM Nodes Using SMF Fiber

Number of Spans	10 Gbps				2.5 Gbps					
	Class A	Class B	Class C	Class I	Class D	Class E	Class F	Class G	Class H	Class J
1	35 dB	25 dB	25 dB	36 dB	37 dB	33 dB	30 dB	32 dB	34 dB	—
2	30 dB	21 dB	20 dB	32 dB	34 dB	28 dB	25 dB	26 dB	29 dB	—
3	28 dB	18 dB	17 dB	30 dB	32 dB	26 dB	23 dB	24 dB	27 dB	—
4	26 dB	—	—	28 dB	30 dB	24 dB	21 dB	22 dB	25 dB	—
5	25 dB	—	—	27 dB	29 dB	23 dB	20 dB	20 dB	23 dB	—
6	24 dB	—	—	26 dB	28 dB	22 dB	18 dB	19 dB	22 dB	—
7	23 dB	—	—	25 dB	27 dB	21 dB	14 dB	17 dB	20 dB	—
8	22 dB	—	—	24 dB	26 dB	20 dB	—	—	18 dB	—
9	21 dB	—	—	23 dB	25 dB	19 dB	—	—	—	—
10	21 dB	—	—	23 dB	25 dB	18 dB	—	—	—	—
11	18 <sup>1</sup> dB	—	—	22 dB	24 dB	17 dB	—	—	—	—
12	17 <sup>1</sup>	—	—	21 dB	24 dB	15 dB	—	—	—	—
13	15 <sup>1</sup>	—	—	21 dB	23 dB	—	—	—	—	—
14	—	—	—	20 dB	23 dB	—	—	—	—	—
15	—	—	—	20 dB	22 dB	—	—	—	—	—

1. If the number of boosters is greater than 10 and power per channel is = to +1 dBm.

[Table 17-13](#) shows the optical performance for 32-channel linear or ring network with ROADM and OADM nodes using SMF fiber. Span loss values assume the following:

- All nodes in the ring or linear network are ROADM or OADM.
- OPT-PRE and OPT-BST/OPT-BST-E amplifiers are installed.
- Span losses are equal.

See [Table 17-2](#) for a list of cards in each class. A dash (—) indicates the spans that are not supported.

**Table 17-13** Span Loss for 32-Channel Ring and Linear Networks with ROADM and OADM Nodes Using SMF Fiber

Number of Spans	10 Gbps				2.5 Gbps					
	Class A	Class B	Class C	Class I	Class D	Class E	Class F	Class G	Class H	Class J
1	30 dB	23 dB	24 dB	31 dB	34 dB	31 dB	28 dB	29 dB	30 dB	28 dB
2	26 dB	19 dB	19 dB	27 dB	27 dB	26 dB	23 dB	26 dB	27 dB	23 dB
3	23 dB	—	—	25 dB	26 dB	23 dB	21 dB	23 dB	24 dB	21 dB
4	21 dB	—	—	23 dB	24 dB	22 dB	18 dB	21 dB	22 dB	18 dB
5	20 dB	—	—	22 dB	23 dB	20 dB	13 dB	20 dB	21 dB	13 dB
6	17 dB	—	—	19 dB	22 dB	18 dB	—	17 dB	18 dB	—
7	15 <sup>1</sup> dB	—	—	17 dB	21 dB	16 dB	—	15 <sup>1</sup>	16 dB	—

- 0.5 dB of OSNR impairment recovered by FEC margin @ BER>10<sup>-6</sup>

The following tables show the pass/fail criteria for eight and sixteen ROADM nodes. [Table 17-14](#) shows the pass/fail criteria for eight ROADM nodes (seven spans) required for any-to-any node circuit reconfigurations:

- All nodes in the ring are ROADM.
- Span losses are equal.

See [Table 17-2](#) for a list of cards in each class. A dash (—) indicates the spans that are not supported.

**Table 17-14** Pass/Fail Criteria for 32-Channel, Eight-Node ROADM Rings Using SMF Fiber

Span Loss (dB)	Amplifiers Installed	10 Gbps				2.5 Gbps					
		Class A	Class B	Class C	Class I	Class D	Class E	Class F	Class G	Class H	Class J
1	OPT-PRE only	Yes	<7	<7	Yes	Yes	Yes	Yes	Yes	Yes	—
2	OPT-PRE only	Yes	<7	<7	Yes	Yes	Yes	Yes	Yes	Yes	—
3	OPT-PRE only	Yes	<7	<7	Yes	Yes	Yes	<7	Yes	Yes	—
4	OPT-PRE only	Yes	<7	<7	Yes	Yes	Yes	<7	Yes	Yes	—
5	OPT-PRE only	Yes	<7	<7	Yes	Yes	Yes	<7	Yes	Yes	—
6	OPT-PRE only	Yes	<7	<7	Yes	Yes	Yes	<7	Yes	Yes	—
7	OPT-PRE and OPT-BST/ OPT-BST-E	Yes	<7	<7	Yes	Yes	Yes	<7	Yes	Yes	—
8	OPT-PRE and OPT-BST/ OPT-BST-E	Yes	<7	<7	Yes	Yes	Yes	<7	Yes	Yes	—
9	OPT-PRE and OPT-BST/ OPT-BST-E	Yes	<7	<7	Yes	Yes	Yes	Yes	Yes	Yes	—
10	OPT-PRE and OPT-BST/ OPT-BST-E	Yes	<7	<7	Yes	Yes	Yes	Yes	Yes	Yes	—
11	OPT-PRE and OPT-BST/ OPT-BST-E	Yes	<7	<7	Yes	Yes	Yes	Yes	Yes	Yes	—
12	OPT-PRE and OPT-BST/ OPT-BST-E	Yes	<7	<7	Yes	Yes	Yes	Yes	Yes	Yes	—
13	OPT-PRE and OPT-BST/ OPT-BST-E	Yes	<7	<7	Yes	Yes	Yes	Yes	Yes	Yes	—

**Table 17-14** Pass/Fail Criteria for 32-Channel, Eight-Node ROADM Rings Using SMF Fiber (continued)

Span Loss (dB)	Amplifiers Installed	10 Gbps				2.5 Gbps					
		Class A	Class B	Class C	Class I	Class D	Class E	Class F	Class G	Class H	Class J
14	OPT-PRE and OPT-BST/ OPT-BST-E	Yes	<7	<7	Yes	Yes	Yes	Yes	Yes	Yes	—
15	OPT-PRE and OPT-BST/ OPT-BST-E	Yes	<7	<7	Yes	Yes	Yes	Yes	Yes	Yes	—

Table 17-15 shows the pass/fail criteria for 16 ROADM nodes (15 spans) required for any-to-any node circuit reconfigurations.

- All nodes in the ring are ROADM.
- Span losses are equal.

See Table 17-2 for a list of cards in each class. A dash (—) indicates the spans that are not supported.

**Table 17-15** Pass/Fail Criteria for 32-Channel, 16-Node ROADM Rings Using SMF Fiber

Span Loss (dB)	Amplifiers Installed	10 Gbps				2.5 Gbps					
		Class A	Class B	Class C	Class I	Class D	Class E	Class F	Class G	Class H	Class J
1	OPT-PRE only	<15 <sup>1</sup>	<15 <sup>1</sup>	<15 <sup>1</sup>	Yes	Yes	<15 <sup>1</sup>	<15 <sup>1</sup>	<15 <sup>1</sup>	<15 <sup>1</sup>	—
2	OPT-PRE only	<15 <sup>1</sup>	<15 <sup>1</sup>	<15 <sup>1</sup>	Yes	Yes	<15 <sup>1</sup>	<15 <sup>1</sup>	<15 <sup>1</sup>	<15 <sup>1</sup>	—
3	OPT-PRE only	<15 <sup>1</sup>	<15 <sup>1</sup>	<15 <sup>1</sup>	Yes	Yes	<15 <sup>1</sup>	<15 <sup>1</sup>	<15 <sup>1</sup>	<15 <sup>1</sup>	—
4	OPT-PRE only	<15 <sup>1</sup>	<15 <sup>1</sup>	<15 <sup>1</sup>	Yes	Yes	<15 <sup>1</sup>	<15 <sup>1</sup>	<15 <sup>1</sup>	<15 <sup>1</sup>	—
5	OPT-PRE only	<15 <sup>1</sup>	<15 <sup>1</sup>	<15 <sup>1</sup>	Yes	Yes	<15 <sup>1</sup>	<15 <sup>1</sup>	<15 <sup>1</sup>	<15 <sup>1</sup>	—
6	OPT-PRE only	<15 <sup>1</sup>	<15 <sup>1</sup>	<15 <sup>1</sup>	Yes	Yes	<15 <sup>1</sup>	<15 <sup>1</sup>	<15 <sup>1</sup>	<15 <sup>1</sup>	—
7	OPT-PRE and OPT-BST/ OPT-BST-E	<15 <sup>1</sup>	<15 <sup>1</sup>	<15 <sup>1</sup>	Yes	Yes	<15 <sup>1</sup>	<15 <sup>1</sup>	<15 <sup>1</sup>	<15 <sup>1</sup>	—
8	OPT-PRE and OPT-BST/ OPT-BST-E	<15 <sup>1</sup>	<15 <sup>1</sup>	<15 <sup>1</sup>	Yes	Yes	<15 <sup>1</sup>	<15 <sup>1</sup>	<15 <sup>1</sup>	<15 <sup>1</sup>	—
9	OPT-PRE and OPT-BST/ OPT-BST-E	<15 <sup>1</sup>	<15 <sup>1</sup>	<15 <sup>1</sup>	Yes	Yes	<15 <sup>1</sup>	<15 <sup>1</sup>	<15 <sup>1</sup>	<15 <sup>1</sup>	—
10	OPT-PRE and OPT-BST/ OPT-BST-E	<15 <sup>1</sup>	<15 <sup>1</sup>	<15 <sup>1</sup>	Yes	Yes	<15 <sup>1</sup>	<15 <sup>1</sup>	<15 <sup>1</sup>	<15 <sup>1</sup>	—
11	OPT-PRE and OPT-BST/ OPT-BST-E	<15 <sup>1</sup>	<15 <sup>1</sup>	<15 <sup>1</sup>	Yes	Yes	<15 <sup>1</sup>	<15 <sup>1</sup>	<15 <sup>1</sup>	<15 <sup>1</sup>	—
12	OPT-PRE and OPT-BST/ OPT-BST-E	<15 <sup>1</sup>	<15 <sup>1</sup>	<15 <sup>1</sup>	Yes	Yes	<15 <sup>1</sup>	<15 <sup>1</sup>	<15 <sup>1</sup>	<15 <sup>1</sup>	—

**Table 17-15** Pass/Fail Criteria for 32-Channel, 16-Node ROADM Rings Using SMF Fiber (continued)

Span Loss (dB)	Amplifiers Installed	10 Gbps				2.5 Gbps					
		Class A	Class B	Class C	Class I	Class D	Class E	Class F	Class G	Class H	Class J
13	OPT-PRE and OPT-BST/ OPT-BST-E	<15 <sup>1</sup>	<15 <sup>1</sup>	<15 <sup>1</sup>	Yes	Yes	<15 <sup>1</sup>	<15 <sup>1</sup>	<15 <sup>1</sup>	<15 <sup>1</sup>	—
14	OPT-PRE and OPT-BST/ OPT-BST-E	<15 <sup>1</sup>	<15 <sup>1</sup>	<15 <sup>1</sup>	Yes	Yes	<15 <sup>1</sup>	<15 <sup>1</sup>	<15 <sup>1</sup>	<15 <sup>1</sup>	—
15	OPT-PRE and OPT-BST/ OPT-BST-E	<15 <sup>1</sup>	<15 <sup>1</sup>	<15 <sup>1</sup>	Yes	Yes	<15 <sup>1</sup>	<15 <sup>1</sup>	<15 <sup>1</sup>	<15 <sup>1</sup>	—

1. Cisco MetroPlanner calculates the maximum ring circumference and number of nodes that can be supported.

## 17.3.4 Optical Performance for Single-Span Networks

Table 17-16 lists the span loss for a single-span link configuration with eight channels. The optical performance for this special configuration is given only for Classes A and C. This configuration assumes a maximum channel capacity of eight channels (8-dBm nominal channel power) used without any restrictions on the 32 available channels.

**Table 17-16** Span Loss for Single-Span Link with Eight Channels

Node Configuration	Number of Spans	10 Gbps			2.5 Gbps			
		Class A	Class B	Class C	Class D	Class E	Class F	Class G
With OSCM card	1	37 dB	—	37 dB	—	—	—	—
With OSC-CSM card	1	35 dB	—	35 dB	—	—	—	—

Table 17-17 lists the span loss for a single-span link configuration with 16 channels. The optical performance for this special configuration is given only for Class A and Class C. This configuration assumes a maximum channel capacity of 16 channels (5-dBm nominal channel power) used without any restrictions on the 32 available channels.

**Table 17-17** Span Loss for Single-Span Link with 16 Channels

Node Configuration	Number of Spans	10 Gbps			2.5 Gbps			
		Class A	Class B	Class C	Class D	Class E	Class F	Class G
With OSCM or OSC-SCM cards	1	35 dB	—	35 dB	—	—	—	—

Table 17-18 lists the span loss for a single-span link configuration with AD-1C-x.xx cards, OPT-PRE amplifiers, and OPT-BST/OPT-BST-E amplifiers. The single-span link with a flexible channel count is used both for transmitting and receiving. If dispersion compensation is required, a DCU can be used with an OPT-PRE amplifier. The optical performance for this special configuration is given for Classes A through G (8-dBm nominal channel power) used without any restrictions on the 32 available channels.

**Table 17-18** *Span Loss for Single-Span Link with AD-1C-xx.x Cards, OPT-PRE Amplifiers, and OPT-BST/OPT-BST-E Amplifiers*

Node Configuration	Number of Spans	10 Gbps			2.5 Gbps			
		Class A	Class B	Class C	Class D	Class E	Class F	Class G
With OSCM cards <sup>1</sup>	1	37 dB	31 dB	31 dB	37 dB	37 dB	37 dB	37 dB
Hybrid with OSC-CSM cards <sup>2</sup>	1	35 dB	31 dB	31 dB	35 dB	35 dB	35 dB	35 dB

1. OSCM sensitivity limits the performance to 37 dB.
2. OSC-CSM sensitivity limits the performance to 35 dB when it replaces the OSCM.

Table 17-19 lists the span loss for a single-span link configuration with one channel and OPT-BST/OPT-BST-E amplifiers. The optical performance for this special configuration is given for Classes A through G. Classes A, B, and C use 8-dBm nominal channel power. Classes D, E, F, and G use 12-dBm nominal channel power. There are no restriction on the 32 available channels. That is, a line card, transponder, or muxponder wavelength can be extracted from the 32 available wavelengths. Also, the optical service channel is not required.

**Table 17-19** *Span Loss for Single-Span Link with One Channel and OPT-BST Amplifiers*

Number of Spans	10 Gbps			2.5 Gbps			
	Class A	Class B	Class C	Class D	Class E	Class F	Class G
1	20 to 30 dB	17 to 26 dB	17 to 28 dB	Unprotected from 29 to 41 dB Protected from 25 to 41 dB	Unprotected from 28 to 37 dB Protected from 24 to 40 dB	Unprotected from 21 to 34 dB Protected from 18 to 34 dB	From 23 to 36 dB

Table 17-20 lists the span loss for a single-span link configuration with one channel, OPT-BST/OPT-BST-E amplifiers, OPT-PRE amplifiers, and ONS 15216 FlexLayer filters. ONS 15216 FlexLayer filters are used instead of the AD-1C-xx.x cards to reduce equipment costs and increase the span length, since the optical service channel is not necessary. The optical performance for this special configuration is given for Classes A through G. Classes A, B, and C use 8-dBm nominal channel power. Classes D, E, F, and G use 12-dBm nominal channel power. There are no restriction on the first 16 available wavelengths (from 1530.33 to 1544.53 nm).

**Table 17-20** *Span Loss for Single-Span Link with One Channel, OPT-BST/OPT-BST-E Amplifiers, OPT-PRE Amplifiers, and ONS 15216 FlexLayer Filters*

Number of Spans	10 Gbps			2.5 Gbps			
	Class A	Class B <sup>1</sup>	Class C <sup>1</sup>	Class D <sup>1</sup>	Class E <sup>1</sup>	Class F <sup>1</sup>	Class G <sup>1</sup>
1x	38 dB	30 dB	30 dB	44 dB	40 dB	38 dB	40 dB

## 17.4 Automatic Power Control

The ONS 15454 automatic power control (APC) feature performs the following functions:

- Maintains constant per-channel power when changes to the number of channels occur.

- Compensates for optical network degradation (aging effects).
- Simplifies the installation and upgrade of DWDM optical networks by automatically calculating the amplifier setpoints.

**Note**

APC functions are performed by software algorithms on the OPT-BST, OPT-PRE, and TCC2/TCC2P cards.

Amplifier software uses a control gain loop with fast transient suppression to keep the channel power constant regardless of any changes in the number of channels. Amplifiers monitor the changes to the input power and change the output power according to the calculated gain setpoint. The shelf controller software emulates the control output power loop to adjust for fiber degradation. To perform this function, the TCC2/TCC2P needs to know the channel distribution, which is provided by a signaling protocol, and the expected per-channel power, which you can provision. The TCC2/TCC2P compares the actual amplifier output power with the expected amplifier output power and modifies the setpoints if any discrepancies occur.

## 17.4.1 APC at the Amplifier Card Level

In constant gain mode, the amplifier power out control loop performs the following input and output power calculations, where  $G$  represents the gain and  $t$  represents time.

$$P_{out}(t) = G * P_{in}(t) \text{ (mW)}$$

$$P_{out}(t) = G + P_{in}(t) \text{ (dB)}$$

In a power-equalized optical system, the total input power is proportional to the number of channels. The amplifier software compensates for any variation of the input power due to changes in the number of channels carried by the incoming signal.

Amplifier software identifies changes in the read input power in two different instances,  $t_1$  and  $t_2$  as a change in the carried traffic. The letters  $m$  and  $n$  in the following formula represent two different channel numbers.  $P_{in}/ch$  represents the per-channel input power:

$$P_{in}(t_1) = nP_{in}/ch$$

$$P_{in}(t_2) = mP_{in}/ch$$

Amplifier software applies the variation in the input power to the output power with a reaction time that is a fraction of a millisecond. This keeps the power constant on each channel at the output amplifier, even during a channel upgrade or a fiber cut.

Amplifier parameters are configured using east and west conventions for ease of use. Selecting west provisions parameters for the preamplifier receiving from the west and the booster amplifier transmitting to the west. Selecting east provisions parameters for the preamplifiers receiving from the east and the booster amplifier transmitting to the east.

Starting from the expected per-channel power, the amplifiers automatically calculate the gain setpoint after the first channel is provisioned. An amplifier gain setpoint is calculated in order to make it equal to the loss of the span preceding the amplifier itself. After the gain is calculated, the setpoint is no longer changed by the amplifier. Amplifier gain is recalculated every time the number of provisioned channels returns to zero. If you need to force a recalculation of the gain, move the number of channels back to zero.

## 17.4.2 APC at the Node and Network Levels

The amplifier adjusts the gain to compensate for span loss. Span loss changes due to aging fiber and components, or changes in operating conditions. To correct the gain or express variable optical attenuator (VOA) setpoints, APC calculates the difference between the power value read by the photodiodes and the expected power value. The expected power values is calculated using:

- Provisioned per-channel power value
- Channel distribution (the number of express, add, and drop channels in the node)
- ASE estimation

Channel distribution is determined by the sum of the provisioned and failed channels. Information about provisioned wavelengths is sent to APC on the applicable nodes during circuit creation. Information about failed channels is collected through a signaling protocol that monitors alarms on ports in the applicable nodes and distributes that information to all the other nodes in the network.

ASE calculations purify the noise from the power level reported from the photodiode. Each amplifier can compensate for its own noise, but cascaded amplifiers cannot compensate for ASE generated by preceding nodes. The ASE effect increases when the number of channels decreases; therefore, a correction factor must be calculated in each amplifier of the ring to compensate for ASE build-up.

APC is a network-level feature. The APC algorithm designates a master node that is responsible for starting APC hourly or every time a new circuit is provisioned or removed. Every time the master node signals for APC to start, gain and VOA setpoints are evaluated on all nodes in the network. If corrections are needed in different nodes, they are always performed sequentially following the optical paths starting from the master node.

APC corrects the power level only if the variation exceeds the hysteresis thresholds of  $\pm 0.5$  dB. Any power level fluctuation within the threshold range is skipped since it is considered negligible. Because APC is designed to follow slow time events, it skips corrections greater than 3 dB. This is the typical total aging margin that is provisioned during the network design phase. After you provision the first channel or the amplifiers are turned up for the first time, APC does not apply the 3 dB rule. In this case, APC corrects all the power differences to turn up the node.

**Note**

---

Software R5.0 does not report corrections that are not performed and exceed the 3 dB correction factor to Cisco Transport Controller (CTC), Cisco Transport Manager (CTM), and Transaction Language One (TL1) management interfaces.

---

To avoid large power fluctuations, APC adjusts power levels incrementally. The maximum power correction is  $\pm 0.5$  dB. This is applied to each iteration until the optimal power level is reached. For example, a gain deviation of 2 dB is corrected in four steps. Each of the four steps requires a complete APC check on every node in the network. APC can correct up to a maximum of 3 dB on an hourly basis. If degradation occurs over a longer time period, APC will compensate for it by using all margins that you provision during installation.

When no margin is available, adjustments cannot be made because setpoints exceed ranges. APC communicates the event to CTC, CTM, and TL1 through an APC Fail condition. APC will clear the APC fail condition when the setpoints return to the allowed ranges.

APC automatically disables itself when:

- A HW FAIL alarm is raised by any card in any of the network nodes.
- A Mismatch Equipment Alarm (MEA) is raised by any card in any of the network nodes.
- An Improper Removal alarm is raised by any card in any of the network nodes.

- Gain Degrade, Power Degrade, and Power Fail Alarms are raised by the output port of any amplifier card in any of the network nodes.
- A VOA degrade or fail alarm is raised by any of the cards in any of the network nodes.

The APC state (Enable/Disable) is located on every node and can be retrieved by the CTC or TL1 interfaces. If an event that disables APC occurs in one of the network nodes, APC is disabled on all the others and the APC state changes to DISABLE - INTERNAL. The disabled state is raised only by the node where the problem occurred to simplify troubleshooting.

APC raises the following standing conditions at the port level in CTC, TL1, and SNMP:

- APC Out of Range—APC cannot assign a new setpoint for a parameter this is allocated to a port because the new setpoint exceeds the parameter range.
- APC Correction Skipped—APC skipped a correction to one parameter allocated to a port because the difference between the expected and current values exceeds the +/- 3 dB security range.

After the error condition is cleared, signaling protocol enables APC on the network and the APC DISABLE - INTERNAL condition is cleared. Because APC is required after channel provisioning to compensate for ASE effects, all optical channel network connection (OCHNC) circuits that you provision during the disabled APC state are kept in the Out-of-Service and Autonomous, Automatic In-Service (OOS-AU,AINS [ANSI]) or Unlocked-disabled,automaticInService (ETSI) service state until APC is enabled. OCHNCs automatically go into the In-Service and Normal (IS-NR [ANSI]) or Unlocked-enabled (ETSI) service state only after APC is enabled.

### 17.4.3 Managing APC

The automatic power control status is indicated by four APC states shown in the node view status area:

- Enable—APC is enabled.
- Disable - Internal—APC has been automatically disabled for an internal cause.
- Disable - User—APC was disabled manually by a user.
- Not Applicable—The node is provisioned to Metro Access or Not DWDM, which do not support APC.

You can view the automatic power control information and disable and enable APC manually on the Maintenance > DWDM > APC subtab (Figure 17-8).



#### Caution

When APC is disabled, aging compensation is not applied and circuits cannot be activated. Do not disable APC unless it is required for specific maintenance or troubleshooting tasks. Always enable APC as soon as the tasks are completed.

Figure 17-8 Automatic Power Control

APC State

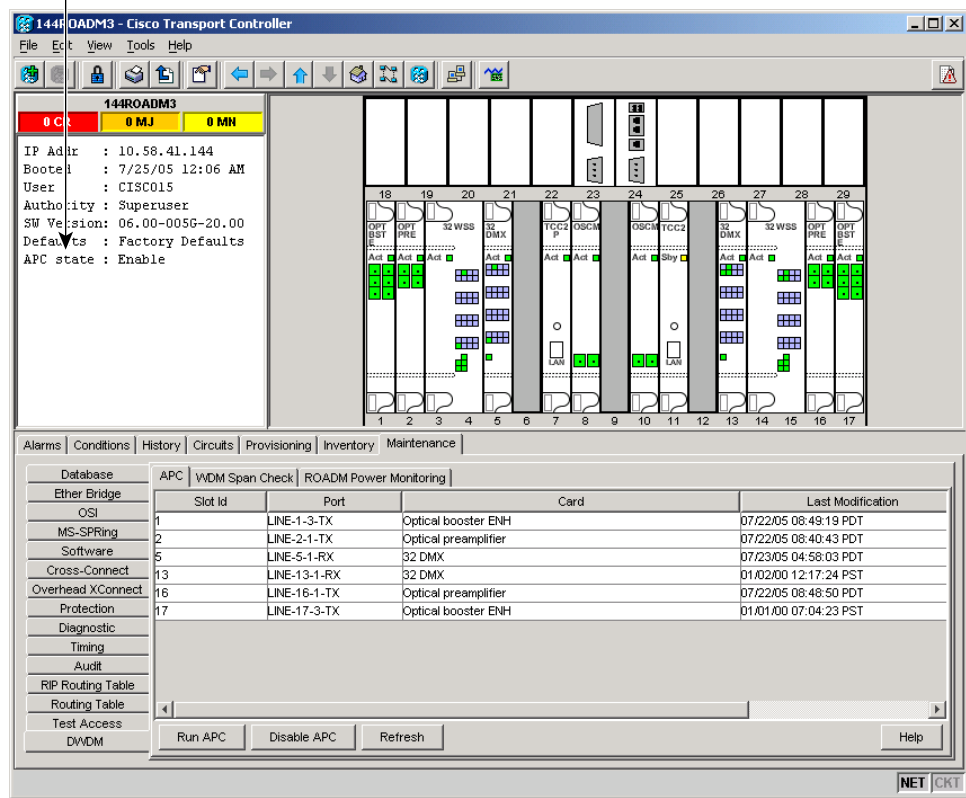

The APC subtab provides the following information:

- Slot ID—The ONS 15454 slot number for which APC information is shown.
- Port—The port number for which APC information is shown.
- Card—The card for which power control information is shown.
- Last Modification—Date and time APC last modified a setpoint for the parameters shown in Table 17-21.
- Last Check—Date and time APC last verified the setpoints for the parameters shown in Table 17-21.

Table 17-21 APC-Managed Parameters

Card	Port	Parameters
OPT-BST	LINE-3-TX	<ul style="list-style-type: none"> <li>• Gain</li> <li>• Total Signal Output Power</li> </ul>
OPT-PRE	LINE-1-TX	<ul style="list-style-type: none"> <li>• Gain</li> <li>• Total Signal Output Power</li> </ul>
AD-xB-xx.x	LINE-1-TX BAND-i-TX	VOA Target Attenuation

Table 17-21 APC-Managed Parameters (continued)

Card	Port	Parameters
AD-1C-xx.x	LINE-1-TX	VOA Target Attenuation
AD-2C-xx.x		
AD-4C-xx.x	LINE-1-TX CHAN-i-TX	VOA Target Attenuation
32-DMX	LINE-1-TX	VOA Target Attenuation

## 17.5 ROADM Power Equalization Monitoring

Reconfigurable OADM (ROADM) nodes allow you to monitor the 32WSS card equalization functions on the Maintenance > DWDM > Power Monitoring subtab (Figure 17-9). The tab shows the input channel power (Padd), the express or pass-through (Ppt) power and the power level at output (Pout).

Figure 17-9 Power Monitoring Subtab

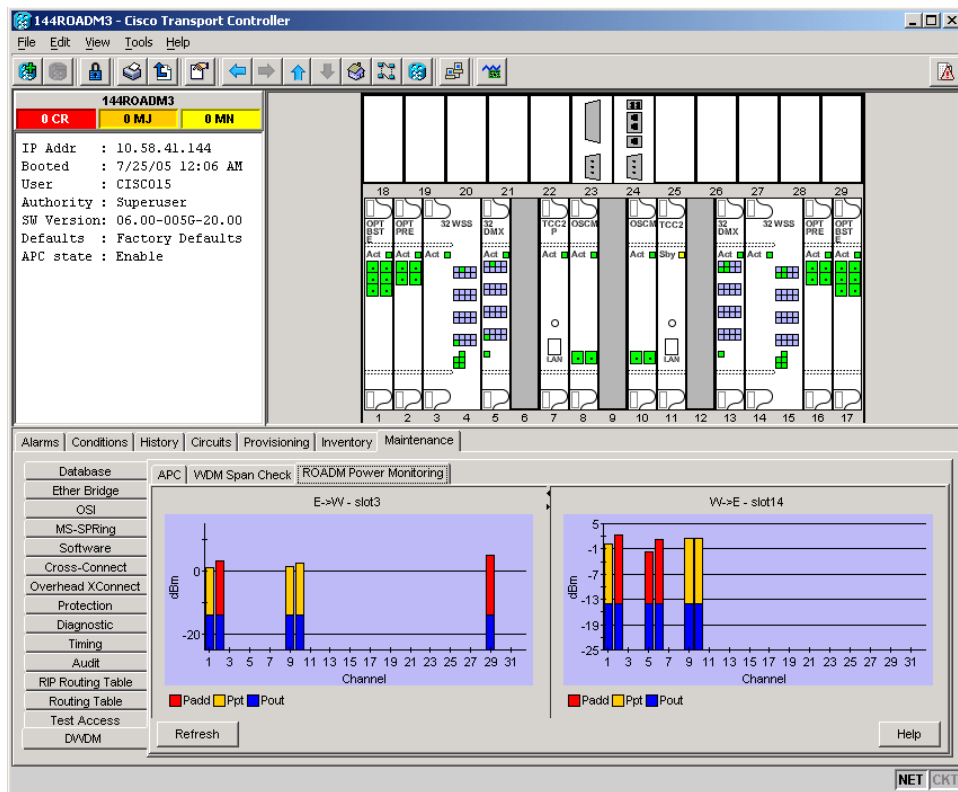

134674

## 17.6 Span Loss Verification

Span loss measurements can be performed from the Maintenance > DWDM > WDM Span Check subtab (Figure 17-10). The CTC span check compares the far-end OSC power with the near-end OSC power. A “Span Loss Out of Range” condition is raised when the measured span loss is higher than the maximum expected span loss. It is also raised when the measured span loss is lower than the minimum expected span loss and the difference between the minimum and maximum span loss values is greater than 1 dB. The minimum and maximum expected span loss values are calculated by Cisco MetroPlanner for the network and imported into CTC. However, you can manually change the minimum and expected span loss values.

CTC span loss measurements provide a quick span loss check and are useful whenever changes to the network occur, for example after you install equipment or repair a broken fiber. CTC span loss measurement resolutions are:

- +/- 1.5 dB for measured span losses between 0 and 25 dB
- +/- 2.5 dB for measured span losses between 25 and 38 dB

For ONS 15454 span loss measurements with higher resolutions, an optical time domain reflectometer (OTDR) must be used.

**Figure 17-10** Span Loss Verification

The screenshot shows the Cisco Transport Controller (CTC) interface for device 144ROADM3. The top left pane displays system information:

```

144ROADM3
0 CR 0 MJ 0 MH
IP Addr : 10.58.41.144
Booted : 7/25/05 12:06 AM
User : CISCO15
Authority : Superuser
SW Version: 06.00-0056-20.00
Defaults : Factory Defaults
APC state : Enable
  
```

The main area shows a rack diagram with 17 slots. The bottom pane displays the WDM Span Check subtab with the following table:

Side	Min Exp. Span Loss (dB)	Max Exp. Span Loss (dB)	Meas. Span Loss (dB)
West	0.0	60.0	N/A
East	0.0	60.0	N/A

Buttons at the bottom include "Retrieve Span Loss values", "Reset", "Apply", and "Help".

134673

## 17.7 Network Optical Safety—Automatic Laser Shutdown

Automatic laser shutdown (ALS) is a technique used to automatically shut down the output power of OSC laser transmitters (contained in the OSCM and OSC-CSM cards) and optical amplifiers (contained in OPT-BST cards) in the event of a fiber break. Cards with OSC laser transmitters and optical amplifiers (OPT-BST only) can be provisioned as follows with respect to ALS:

- **Disable:** ALS is off; the laser and optical amplifiers (OPT-BST only) is not automatically shut down when a traffic outage loss of signal (LOS) occurs
- **Auto Restart:** ALS is on. The laser and optical amplifiers (OPT-BST only) automatically shuts down when traffic outages (LOS) occur. It automatically restarts when the conditions that caused the outage are resolved.



### Note

---

Auto Restart is the default ALS provisioning.

---

- **Manual Restart:** ALS is on. The laser and optical amplifiers (OPT-BST only) automatically shuts down when traffic outages (LOS) occur. However, the laser must be manually restarted when conditions that caused the outage are resolved.
- **Manual Restart for Test:** Manually restarts the laser and optical amplifiers (OPT-BST only) for testing.

In the following paragraphs, two ALS scenarios are given:

- Nodes using OPT-BST cards (amplified nodes)
- Nodes using OSC-CSM cards (passive nodes)

### 17.7.1 Scenario 1: Fiber Cut in Nodes Using OPT-BST/OPT-BST-E Cards

Figure 17-11 shows nodes using OPT-BST/OPT-BST-E cards with a fiber cut between them.

Figure 17-11 Nodes Using OPT-BST/OPT-BST-E Cards

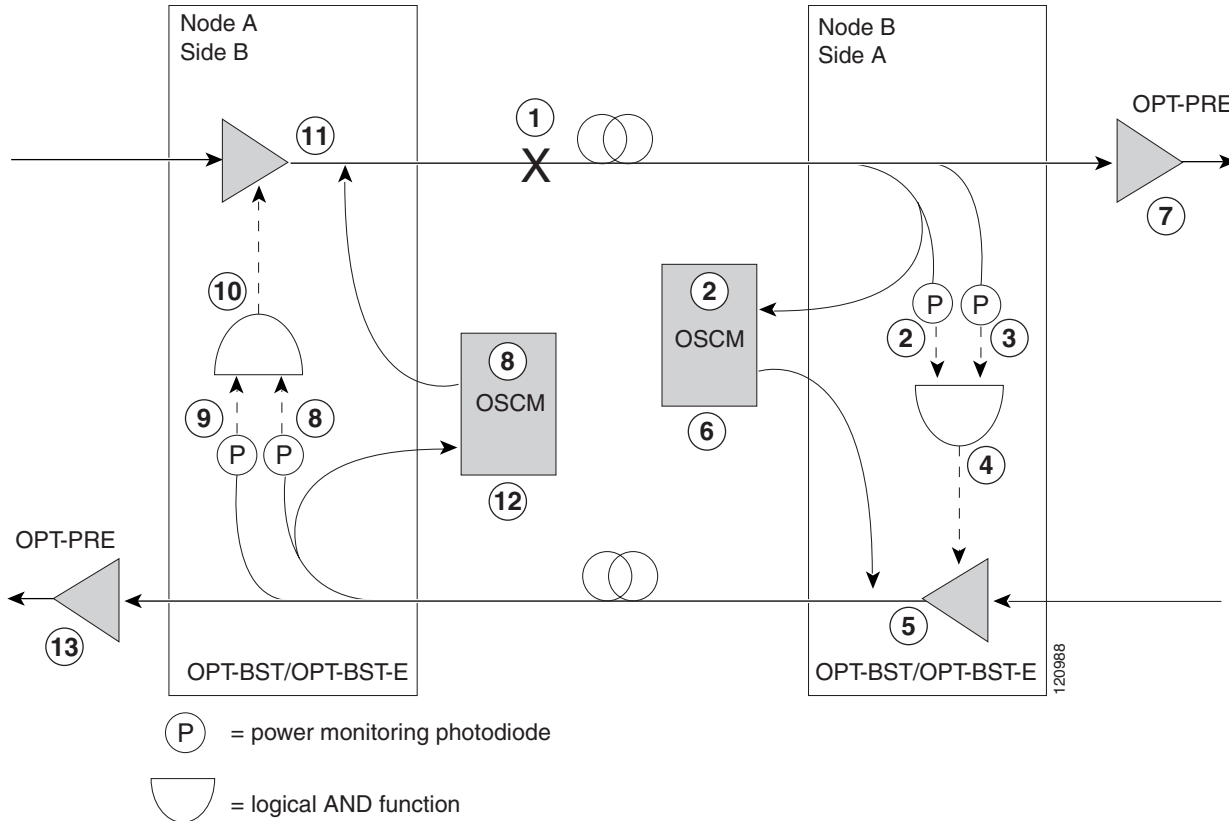

Two photodiodes at Node B monitor the received signal strength for the optical payload and optical service channel (OSC) signals. When the fiber is cut, a loss of signal (LOS) is detected at both of the photodiodes. The AND function then indicates an overall LOS condition, which causes the OPT-BST/OPT-BST-E transmitter, OPT-PRERECEIVER, and OSCM lasers to shut down. This in turn leads to a LOS for both the optical payload and OSC at Node A, which causes Node A to turn off the OSCM, OPT-PRERECEIVER, and OPT-BST/OPT-BST-E transmitter lasers. The sequence of events after a fiber cut is as follows (refer to the numbered circles in Figure 17-11):

1. Fiber is cut.
2. Node B power monitoring photodiode detects a Loss of Incoming Overhead (LOS-O) on the OPT-BST/OPT-BST-E card and the OSCM card detects a LOS (OC3) at the SONET layer. Refer to the *Cisco ONS 15454 Troubleshooting Guide* or the *Cisco ONS 15454 SDH Troubleshooting Guide*.
3. Node B power monitoring photodiode detects a Loss of Incoming Payload (LOS-P) on the OPT-BST/OPT-BST-E card. Refer to the *Cisco ONS 15454 Troubleshooting Guide* or the *Cisco ONS 15454 SDH Troubleshooting Guide*.
4. On the OPT-BST/OPT-BST-E card, the simultaneous LOS-O and LOS-P detection triggers a command to shut down the amplifier. CTC reports an LOS alarm (loss of continuity), while LOS-O and LOS-P are demoted. Refer to the *Cisco ONS 15454 Troubleshooting Guide* or the *Cisco ONS 15454 SDH Troubleshooting Guide*.
5. The OPT-BST/OPT-BST-E card amplifier is shut down within three seconds.
6. The OSCM laser is shut down.
7. The OPT-PRERECEIVER card automatically shuts down due to a loss of incoming optical power

8. Node A power monitoring photodiode detects a LOS-O on the OPT-BST/OPT-BST-E card and the OSCM card detects a LOS (OC3) at the SONET layer. Refer to the *Cisco ONS 15454 Troubleshooting Guide* or the *Cisco ONS 15454 SDH Troubleshooting Guide*.
9. Node A power monitoring photodiode detects a LOS-P on the OPT-BST/OPT-BST-E card. Refer to the *Cisco ONS 15454 Troubleshooting Guide* or the *Cisco ONS 15454 SDH Troubleshooting Guide*.
10. On the OPT-BST, the simultaneous LOS-O and LOS-P detection triggers a command to shut down the amplifier. CTC reports an LOS alarm (loss of continuity), while LOS-O and LOS-P are demoted. Refer to the *Cisco ONS 15454 Troubleshooting Guide* or the *Cisco ONS 15454 SDH Troubleshooting Guide*.
11. The OPT-BST/OPT-BST-E card amplifier is shut down within three seconds.
12. The OSCM laser is shut down.



---

**Note** The shutdown of the OPT-BST/OPT-BST-E and OSCM cards, which launch power into the cut fiber, achieves the aim of the Network Optical Safety feature.

---

13. The node A OPT-PRE card automatically shuts down due to a loss of incoming optical power.

When the fiber is repaired, either an automatic or manual restart at the Node A OPT-BST/OPT-BST-E transmitter or at the Node B OPT-BST/OPT-BST-E transmitter is required. A system that has been shut down is reactivated through the use of a restart pulse. The pulse is used to signal that the optical path has been restored and transmission can begin. For example, when the far end, Node B, receives a pulse, it signals to the Node B OPT-BST/OPT-BST-E transmitter to begin transmitting an optical signal. The OPT-BST/OPT-BST-E receiver at Node A receives that signal and signals the Node A OPT-BST/OPT-BST-E transmitter to resume transmitting.



---

**Note** During a laser restart pulse, automatic power reduction (APR) is disabled and the laser power does not exceed Class 1 limits.

---

## 17.7.2 Scenario 2: Fiber Cut in Nodes Using OSC-CSM Cards

Figure 17-12 shows nodes using OSC-CSM cards with a fiber cut between them.

Figure 17-12 Nodes Using OSC-CSM Cards

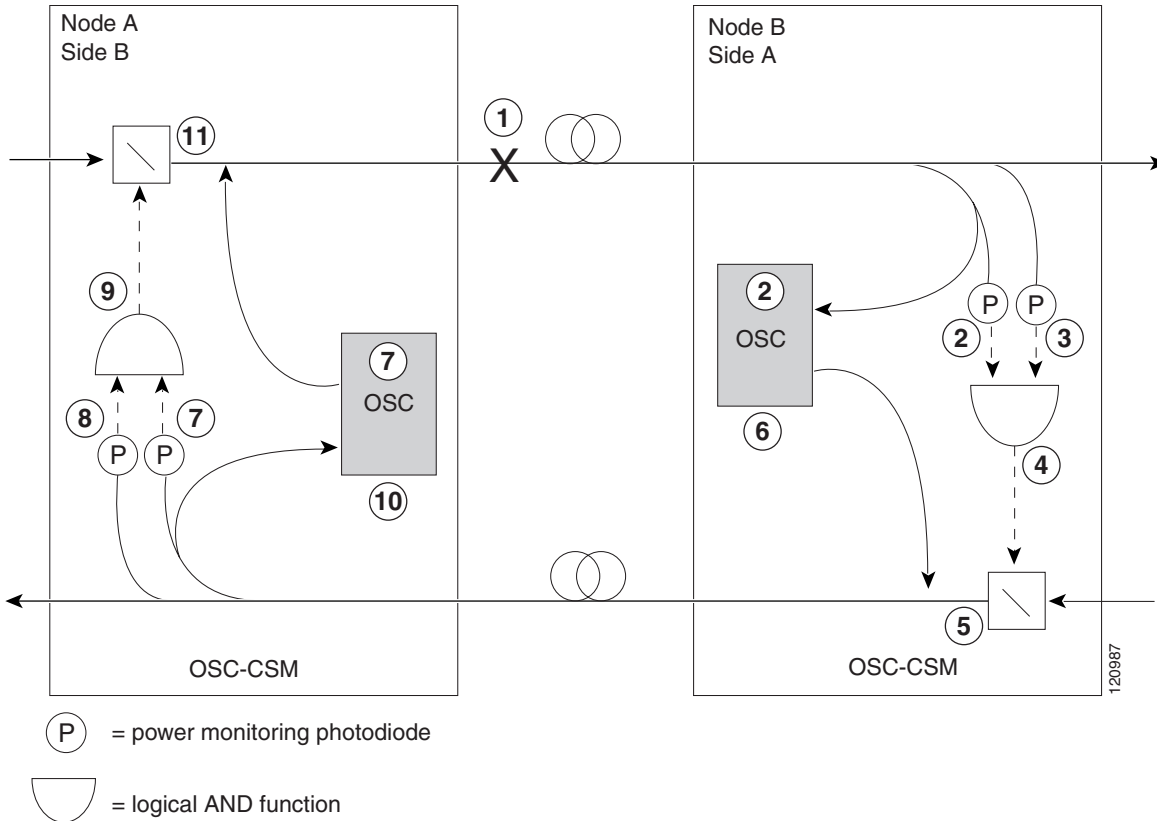

Two photodiodes at the Node B OSC-CSM card monitor the received signal strength for the received optical payload and OSC signals. When the fiber is cut, LOS is detected at both of the photodiodes. The AND function then indicates an overall LOS condition, which causes the Node B OSC laser to shut down and the optical switch to block traffic. This in turn leads to LOS for both the optical payload and OSC signals at Node A, which causes Node A to turn off the OSC laser and the optical switch to block outgoing traffic. The sequence of events after a fiber cut is as follows (refer to the numbered circles in Figure 17-12):

1. Fiber is cut.
2. Node B power monitoring photodiode detects a LOS-O on the OSC-CSM card. Refer to the *Cisco ONS 15454 Troubleshooting Guide* or the *Cisco ONS 15454 SDH Troubleshooting Guide*.
3. Node B power monitoring photodiode detects a LOS-P on the OSC-CSM card. Refer to the *Cisco ONS 15454 Troubleshooting Guide* or the *Cisco ONS 15454 SDH Troubleshooting Guide*.
4. On the OSC-CSM, the simultaneous LOS-O and LOS-P detection triggers a change in the position of the optical switch. CTC reports a LOS alarm (loss of continuity), while LOS-O and LOS-P are demoted. Refer to the *Cisco ONS 15454 Troubleshooting Guide* or the *Cisco ONS 15454 SDH Troubleshooting Guide*.
5. The optical switch blocks outgoing traffic.
6. The OSC laser is shut down.
7. Node A power monitoring photodiode detects a LOS-O on the OSC-CSM card. Refer to the *Cisco ONS 15454 Troubleshooting Guide* or the *Cisco ONS 15454 SDH Troubleshooting Guide*.

8. Node A power monitoring photodiode detects a LOS-P on the OSC-CSM card. Refer to the *Cisco ONS 15454 Troubleshooting Guide* or the *Cisco ONS 15454 SDH Troubleshooting Guide*.
9. On the OSC-CSM, the simultaneous LOS-O and LOS-P detection triggers a change in the position of the optical switch. CTC reports a LOS alarm (loss of continuity), while LOS-O and LOS-P are demoted. Refer to the *Cisco ONS 15454 Troubleshooting Guide* or the *Cisco ONS 15454 SDH Troubleshooting Guide*.
10. The OSC laser is shut down.
11. The optical switch blocks outgoing traffic.

When the fiber is repaired, either an automatic or manual restart at the Node A OSC-CSM OSC or at the Node B OSC-CSM OSC is required. A system that has been shut down is reactivated through the use of a restart pulse. The pulse is used to signal that the optical path has been restored and transmission can begin. For example, when the far-end Node B receives a pulse, it signals to the Node B OSC to begin transmitting its optical signal and for the optical switch to pass incoming traffic. The OSC-CSM at Node A then receives the signal and tells the Node A OSC to resume transmitting and for the optical switch to pass incoming traffic.

## 17.8 Network-Level Gain—Tilt Management of Optical Amplifiers

The ability to control and adjust per channel optical power equalization is a principal feature of ONS 15454 DWDM Metro-Core network applications. A critical parameter to assure optical spectrum equalization throughout the DWDM system is the gain flatness of EDFA amplifiers.

Two items, gain tilt and gain ripple, are factors in the power equalization of optical amplifier cards such as the OPT-BST/OPT-BST-E or OPT-PRE. [Figure 17-13](#) is a graph of the amplifier output power spectrum and how it is affected by gain tilt and gain ripple.

Figure 17-13 Effect of Gain Ripple and Gain Tilt on Amplifier Output Power

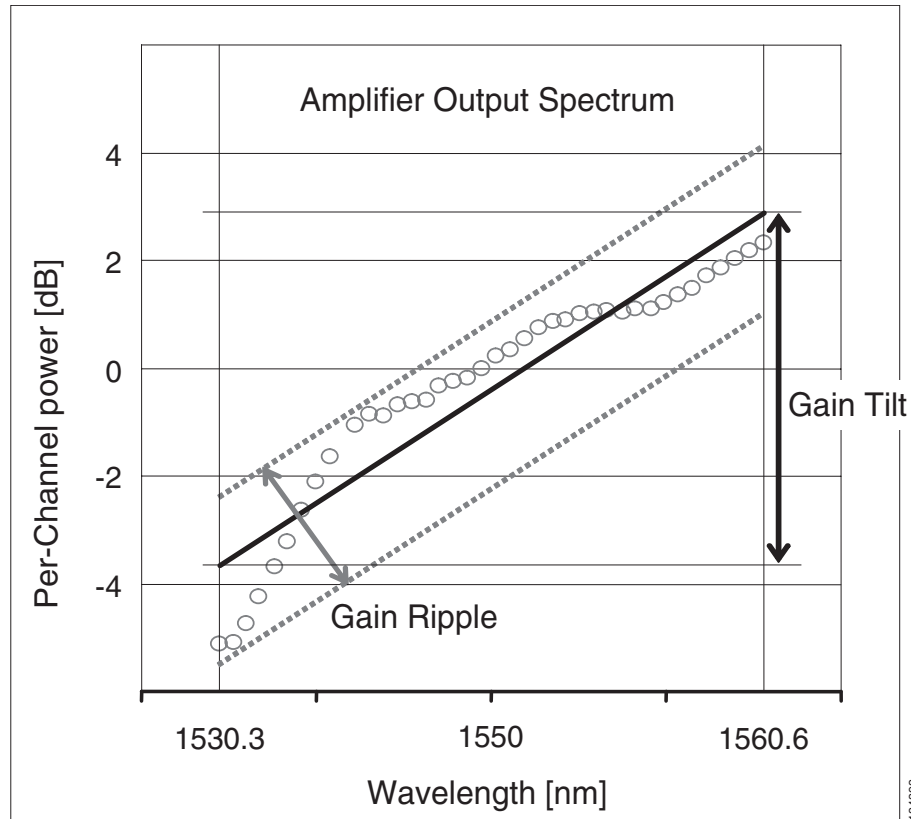

Gain ripple and gain tilt are defined as follows:

- Gain Ripple is random and depends on the spectral shape of the amplifier optical components.
- Gain Tilt is systematic and depends on the gain setpoint (Gstp) of the optical amplifier, which is a mathematical function  $F(Gstp)$  that relates to the internal amplifier design.

Gain tilt is the only contribution to the power spectrum disequalization that can be compensated at the card level. A Variable Optical Attenuator (VOA) internal to the amplifier can be used to compensate for gain tilt.

An Optical Spectrum Analyzer (OSA) device is used to acquire the output power spectrum of an amplifier. The OSA shows the peak-to-peak difference between the maximum and minimum power levels, and takes into account the contributions of both gain tilt and gain ripple.



**Note**

Peak-to-peak power acquisition using an OSA cannot be used to “measure” the Gain Tilt, because gain ripple itself is a component of the actual measurement.

## 17.8.1 Gain Tilt Control at the Card Level

The OPT-BST/OPT-BST-E and OPT-PRE amplifier cards have a “flat” output (gain tilt = 0 dB) for only a specific gain value (Gdesign), based on the internal optical design (see Figure 17-14).

Figure 17-14 Flat Gain (Gain Tilt = 0 dB)

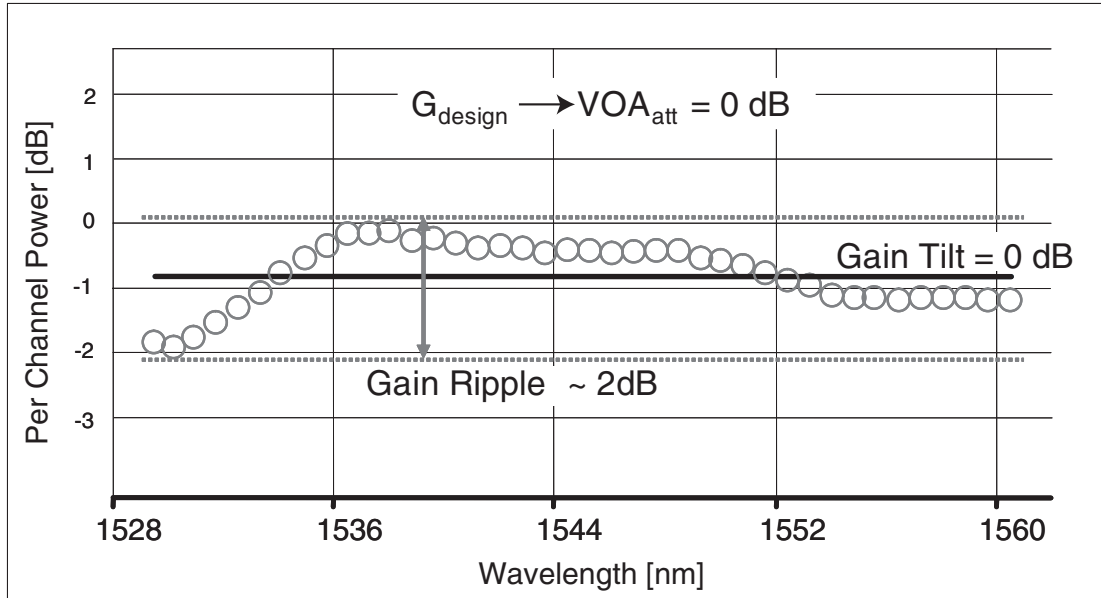

If the “working” gain setpoint of the amplifier is different from  $G_{\text{design}}$ , the output spectrum begins to suffer a gain tilt variation.

In order to compensate for the absolute value of the increase of the spectrum tilt, the OPT-BST/OPT-BST-E and OPT-PRE cards automatically adjust the attenuation of the VOA to maintain a flat power profile at the output, as shown in Figure 17-15.

Figure 17-15 Effect of VOA Attenuation on Gain Tilt

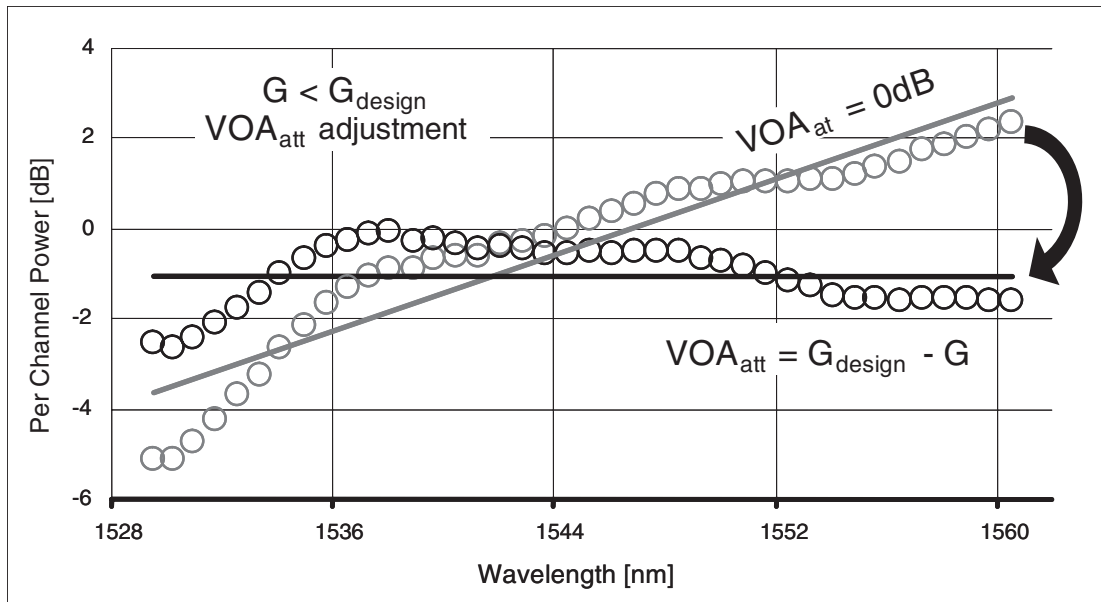

The VOA attenuator automatic regulation guarantees (within limits) a “zero tilt” condition in the EDFA amplifier for a wide range of possible gain setpoint values.

Table 17-22 shows the “flat output” gain range limits for the OPT-BST/OPT-BST-E and OPT-PRE cards, as well as the maximum (worst case) values of gain tilt and gain ripple expected in the specific gain range.

**Table 17-22 Flat Output Gain Range Limits**

Amplifier Card Type	Flat Output Gain Range	Gain Tilt (Maximum)	Gain Ripple (Maximum)
OPT-BST/ OPT-BST-E	$G < 20$ dB	0.5 dB	1.5 dB
OPT-PRE	$G < 21$ dB	0.5 dB	1.5 dB

If the “operating” gain value is outside of the range shown in Table 17-22, the EDFA amplifier introduces a tilt contribution for which the card itself cannot directly compensate. This condition is managed in different ways, depending the amplifier card type:

- OPT-BST/OPT-BST-E. The OPT-BST/OPT-BST-E amplifier is, by card design, not allowed to work outside the “zero tilt” range. The MetroPlanner tool validates network designs using the OPT-BST/OPT-BST-E amplifier card only when the gain is less than or equal to 20 dB.
- OPT-PRE. The MetroPlanner tool allows network designs even if the operating gain value is equal to or greater than 21 dB. In this case, a system-level tilt compensation strategy is adopted by the DWDM system. A more detailed explanation is given in the following section.

## 17.8.2 System Level Gain Tilt Control

System level gain tilt control for OPT-PRE cards is achievable with two main scenarios:

- Without a reconfigurable optical add-drop multiplexer (ROADM) node
- With a ROADM node

### 17.8.2.1 System Gain Tilt Compensation Without ROADM Nodes

When an OPT-PRE card along a specific line direction (West to East or East to West) is working outside the “flat output” gain range ( $G > 21$  dB), the unregulated tilt is compensated for in spans not facing ROADM nodes by configuring an equal but opposite tilt on one or more of the amplifiers in the downstream direction. The number of downstream amplifiers involved depends on the amount of tilt compensation needed and the gain setpoint of the amplifiers that are involved. See Figure 17-16.

**Figure 17-16 System Tilt Compensation Without a ROADM**

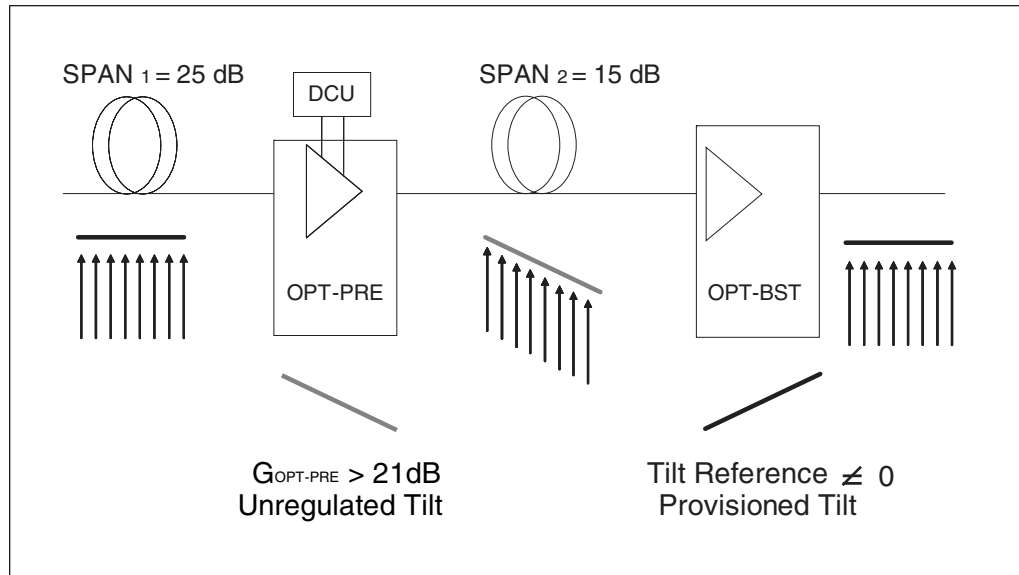

134396

The proper Tilt Reference value is calculated by MetroPlanner and inserted in the Installation Parameter List imported during the Node Turn-Up procedure (see “[NTP-G138 Import a Cisco MetroPlanner Configuration File](#)” task on page 3-72). For both OPT-PRE and OPT-BST/OPT-BST-E cards, the provisionable Gain Tilt Reference range is between  $-3$  dB and  $+3$  dB.

During the Automatic Node Setup (ANS) procedure, the Tilt value for the OPT-BST/OPT-BST-E or OPT-PRE card is provisioned by the TCC card (see [Figure 17-17](#)). The provisioned Tilt Reference Value is reported in the CTC OPT-PRE or OPT-BST/OPT-BST-E card view (Provisioning > Opt.Ampli.Line > Parameters > Tilt Reference).

Figure 17-17 MetroPlanner Installation Parameters

Side	Position	Unit	Port#	Port ID	Port Label	Parameter	Value	Measurement Unit	Manual Set
N/A						NetworkType	Metro-Core	string	No
SideEast	Rack #1 Main Shelf 16	15454E-OPT-PRE	2	LINE-16-1-TX	COM-TX	dwdm:Rc:SideEast:Amplifier:ChPower	2.0	dBm	No
SideEast	Rack #1 Main Shelf 16	15454E-OPT-PRE	2	LINE-16-1-TX	COM-TX	dwdm:Rc:SideEast:Amplifier:Tilt	-3.0	dB	No
SideEast	Rack #1 Main Shelf 16	15454E-OPT-PRE	2	LINE-16-1-TX	COM-TX	dwdm:Rc:SideEast:Amplifier:WorkingMode	Control Gain	string	No
SideEast						dwdm:Rc:SideEast:MaxExpectedSpanLoss	25.0	dB	No
SideEast						dwdm:Rc:SideEast:MinExpectedSpanLoss	25.0	dB	No
SideEast						dwdm:Rc:SideEast:Power:Add-and-DropInputPower	2.0	dBm	No
SideEast	Rack #1 Main Shelf 16	15454E-OPT-PRE	2	LINE-16-1-TX	COM-TX	dwdm:Rc:SideEast:Threshold:AmplifierInPowerFail	-30.6	dBm	No
SideEast						dwdm:Rc:SideEast:Threshold:ChannelLOS	-29.6	dBm	No
SideEast						dwdm:Rc:SideEast:Threshold:OSC-LOS	-36.3	dBm	No
SideEast	Rack #1 Main Shelf 17	15454E-OPT-BST	6	LINE-17-3-TX	LINE-TX	dwdm:Tx:SideEast:Amplifier:ChPower	2.0	dBm	No
SideEast	Rack #1 Main Shelf 17	15454E-OPT-BST	6	LINE-17-3-TX	LINE-TX	dwdm:Tx:SideEast:Amplifier:Tilt	3.0	dB	No
SideEast	Rack #1 Main Shelf 17	15454E-OPT-BST	6	LINE-17-3-TX	LINE-TX	dwdm:Tx:SideEast:Amplifier:WorkingMode	Control Gain	string	No
SideEast						dwdm:Tx:SideEast:Power:Add-and-DropOutputPo...	-8.0	dBm	No
SideEast						dwdm:Tx:SideEast:Threshold:FiberStageInput	-13.0	dBm	No
SideWest	Rack #1 Main Shelf 02	15454E-OPT-PRE	2	LINE-2-1-TX	COM-TX	dwdm:Rc:SideWest:Amplifier:ChPower	2.0	dBm	No
SideWest	Rack #1 Main Shelf 02	15454E-OPT-PRE	2	LINE-2-1-TX	COM-TX	dwdm:Rc:SideWest:Amplifier:Tilt	-3.0	dB	No
SideWest	Rack #1 Main Shelf 02	15454E-OPT-PRE	2	LINE-2-1-TX	COM-TX	dwdm:Rc:SideWest:Amplifier:WorkingMode	Control Gain	string	No
SideWest						dwdm:Rc:SideWest:MaxExpectedSpanLoss	25.0	dB	No
SideWest						dwdm:Rc:SideWest:MinExpectedSpanLoss	25.0	dB	No
SideWest						dwdm:Rc:SideWest:Power:Add-and-DropInputPow...	2.0	dBm	No
SideWest	Rack #1 Main Shelf 02	15454E-OPT-PRE	2	LINE-2-1-TX	COM-TX	dwdm:Rc:SideWest:Threshold:AmplifierInPowerFail	-29.8	dBm	No
SideWest						dwdm:Rc:SideWest:Threshold:ChannelLOS	-28.8	dBm	No
SideWest						dwdm:Rc:SideWest:Threshold:OSC-LOS	-36.3	dBm	No
SideWest	Rack #1 Main Shelf 04	15454E-OPT-BST	6	LINE-1-3-TX	LINE-TX	dwdm:Rc:SideWest:Amplifier:ChPower	3.0	dBm	No
SideWest	Rack #1 Main Shelf 04	15454E-OPT-BST	6	LINE-1-3-TX	LINE-TX	dwdm:Tx:SideWest:Amplifier:Tilt	3.0	dB	No
SideWest	Rack #1 Main Shelf 04	15454E-OPT-BST	6	LINE-1-3-TX	LINE-TX	dwdm:Tx:SideWest:Amplifier:WorkingMode	Control Gain	string	No
SideWest						dwdm:Tx:SideWest:Power:Add-and-DropOutputPo...	-8.0	dBm	No
SideWest						dwdm:Tx:SideWest:Threshold:FiberStageInput	-13.0	dBm	No

134398

### 17.8.2.2 System Gain Tilt Compensation With ROADM Nodes

When an ROADM Node is present in the network, as shown in Figure 17-18, a per-channel dynamic gain equalization can be performed. Both gain tilt and gain ripple are completely compensated using the following techniques:

- Implementing the per-channel VOAs present inside the 32-WSS, and
- Operating in Power Control Mode with the specific power setpoint designed by MetroPlanner.

Figure 17-18 System Tilt Compensation With a ROADM

