



Add and Remove BLSR or Path Protection Nodes



Note

The terms "Unidirectional Path Switched Ring" and "UPSR" may appear in Cisco literature. These terms do not refer to using Cisco ONS 15xxx products in a unidirectional path switched ring configuration. Rather, these terms, as well as "Path Protected Mesh Network" and "PPMN," refer generally to Cisco's path protection feature, which may be used in any topological network configuration. Cisco does not recommend using its path protection feature in any particular topological network configuration.

This chapter explains how to add and remove nodes Cisco ONS 15327 nodes from bidirectional line switched rings (BLSRs) and path protection configurations.

Before You Begin

Before performing any of the following procedures, complete the [“NTP-B195 Document Existing Provisioning” procedure on page 6-2](#). Also investigate all alarms and clear any trouble conditions. Refer to the *Cisco ONS 15327 Troubleshooting Guide* as necessary.

This section lists the chapter procedures (NTPs). Turn to a procedure for applicable tasks (DLPs).

1. [NTP-B12 Add a BLSR Node, page 13-2](#)—Complete as needed.
2. [NTP-B213 Remove a BLSR Node, page 13-8](#)—Complete as needed.
3. [NTP-B105 Add a Path Protection Node, page 13-13](#)—Complete as needed.
4. [NTP-B106 Remove a Path Protection Node, page 13-15](#)—Complete as needed.

NTP-B12 Add a BLSR Node

Purpose	This procedure expands a BLSR by adding a node.
Tools/Equipment	Fiber for new node connections
Prerequisite Procedures	Cards must be installed and node turn-up procedures completed on the node that will be added to the BLSR. See Chapter 1, “Install Hardware,” and Chapter 3, “Turn Up Node.” NTP-108 Back Up the Database, page 14-6
Required/As Needed	As needed
Onsite/Remote	Onsite
Security Level	Provisioning or higher



Caution

Adding a BLSR node can be service affecting and should be performed during a maintenance window.



Note

If the node you are adding to the BLSR is not provisioned as an external network element (ENE) is on the same subnet as other BLSR nodes and CTC computers are directly connected to BLSR nodes, you expect a CTC computer will connect to it,

Step 1

Draw a diagram of the BLSR where you will add the node. In the diagram, identify the east and west BLSR OC-N trunk (span) cards that will connect to the new node. This information is essential to complete this procedure without error. [Figure 13-1](#) shows a drawing of a three-node, two-fiber BLSR that uses Slots 1 and 2 for the BLSR trunk cards.

Figure 13-1 Three-Node Two-Fiber BLSR Before a Fourth Node Is Added

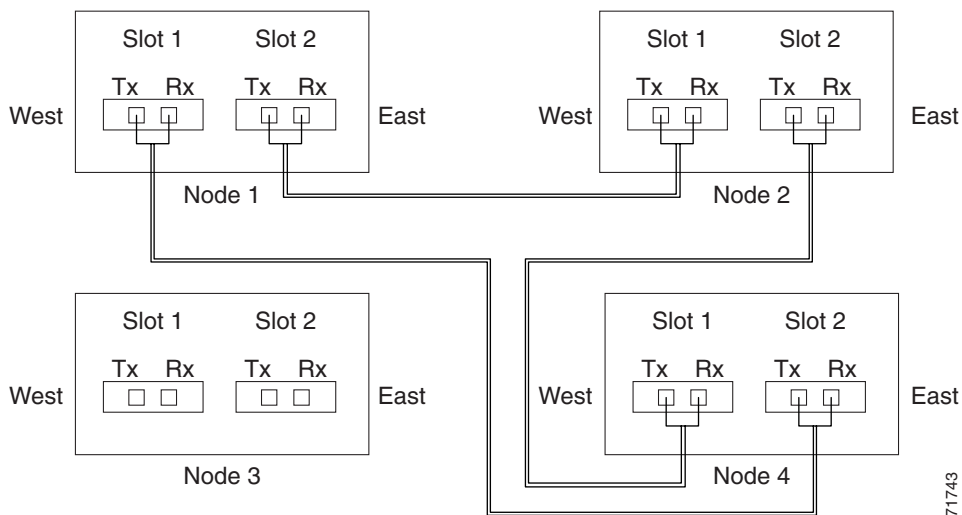

71743

- Step 2** Verify the card installation on the new node using the “[NTP-B24 Verify Card Installation](#)” procedure on [page 3-2](#). Verify that the OC-N cards that will be the BLSR trunk (span) cards match the BLSR optical rate. For example, if the BLSR is OC-48, the new node must have OC-48 cards installed. If the OC-N cards are not installed or the optical rates do not match the BLSR, complete the “[NTP-B218 Install the Optical and Ethernet Cards](#)” procedure on [page 1-23](#).
- Step 3** Verify that fiber is available to connect the new node to the existing nodes. Refer to the diagram drawn in [Step 1](#).
- Step 4** Complete the “[NTP-B35 Verify Node Turn Up](#)” procedure on [page 4-2](#). In order to have CTC visibility to the new node after it is added, you must be an authorized user on the node and you must have IP connectivity to the node.
- Step 5** Log into a node that is in the BLSR. See the “[DLP-B60 Log into CTC](#)” task on [page 2-23](#).
- Step 6** Complete the “[DLP-B302 Check BLSR or Path Protection Alarms and Conditions](#)” task on [page 13-5](#) to verify that the BLSR is free of major alarms or problems. If trouble is indicated (for example, a major alarm exists), resolve the problem before proceeding. See [Chapter 6, “Manage Alarms”](#) or, if necessary, refer to the *Cisco ONS 15327 Troubleshooting Guide*.
- Step 7** Click the **Provisioning > BLSR** tabs.
- Step 8** On paper, record the Ring ID, Ring Type, Line Rate, and Ring Reversion.
- Step 9** From the Node column, record the Node IDs in the BLSR. The Node IDs are the numbers in parentheses next to the node name.
- Step 10** Log into the new node:
- If the node has a LAN connection and is displayed on the network map, from the View menu, choose **Go to Other Node**, then choose the new node from the Select Node to Go to pull-down menu on the Select Node dialog box and click **OK**.
 - If the new node is not connected to the network, log into it directly using the “[DLP-B60 Log into CTC](#)” task on [page 2-23](#).
- Step 11** Click the **Alarms** tab. Verify that no critical or major alarms are present, nor any facility alarms, such as LOS, LOF, AIS-L, SF, and SD. If trouble is indicated (for example, a major alarm exists), resolve the problem before proceeding. See [Chapter 6, “Manage Alarms”](#) or, if necessary, refer to the *Cisco ONS 15327 Troubleshooting Guide*.
- Step 12** Complete the following steps if the node is on the same subnet as other BLSR nodes, it is not provisioned as an external network element (see “[NTP-B169 Set Up CTC Network Access](#)” procedure on [page 3-7](#)), and a CTC computer will directly connect to the node while other CTC computers are directly connected to other BLSR nodes. If not, continue with [Step 13](#).
- a. Click the **Provisioning > Network > General** tabs. View the IP Address and Net/Subnet Mask Length fields to verify the node is on the same subnet as other BLSR nodes.
 - b. Click the **Static Route** tab and click **Create**.
 - c. In the Create Static Route dialog box, enter the following settings:
 - Destination IP address: *Local PC IP address*
 - Net Mask: **255.255.255.255**
 - Next Hop: *IP address of the Cisco ONS 15327*
 - Cost: **1**
 - d. Click **OK**.
- Step 13** Using the information recorded in [Steps 8 and 9](#) and the diagram created in [Step 1](#), create a BLSR on the new node. See the “[DLP-B242 Create a BLSR on a Single Node](#)” task on [page 13-5](#).

Step 14 (Optional) Create test circuits, making sure they pass through the BLSR trunk cards, and run test traffic through the node to ensure that the cards are functioning properly. See the “[NTP-B189 Create a Manually Routed OC-N Circuit](#)” procedure on page 5-44 and the “[NTP-B62 Test OC-N Circuits](#)” procedure on page 5-52 for information.

Step 15 Create the DCC terminations on the new node. See the “[DLP-B253 Provision SONET DCC Terminations](#)” task on page 4-5.



Note Creating the DCC terminations causes the SDCC Termination Failure and Loss of Signal alarms to appear. These alarms will remain active until you connect the node to the BLSR.



Note If you map the K3 byte to another byte (such as E2), you must remap the line cards on either side of the new node to the same byte. See the “[DLP-A89 Remap the K3 Byte](#)” task on page 5-16.

Step 16 Log into a BLSR node that will connect to the new node using one of the login options in [Step 10](#).

Step 17 Referring to the diagram created in [Step 1](#), complete the “[DLP-B303 Initiate a BLSR Force Ring Switch](#)” task on page 13-6 on the node that will connect to the new node via its west port.

Step 18 Referring to the diagram created in [Step 1](#), complete the “[DLP-B303 Initiate a BLSR Force Ring Switch](#)” task on page 13-6 on the node that will connect to the new node via its east port.

Step 19 Click the **Alarms** tab. If unexpected critical or major alarms are present, resolve them before you continue. If necessary, refer to the alarm troubleshooting procedures in the *Cisco ONS 15327 Troubleshooting Guide*.

Step 20 Following the diagram created in [Step 1](#), remove the fiber connections from the two nodes that will connect to the new node.

- a. Remove the west fiber from the node that will connect to the east port of the new node. In the [Figure 13-1](#) example, this is Node 1/Slot 1
- b. Remove the east fiber from the node that will connect to the west port of the new node. In the [Figure 13-1](#) example, this is Node 4/Slot 2.

Step 21 Connect fibers from the adjacent nodes to the new node following the diagram created in [Step 1](#). Connect the west port to the east port and the east port to the west port.

Step 22 Display the newly added node in node view.

Step 23 Click the **Provisioning > BLSR** tabs.

Step 24 Click **Ring Map**. Verify that the new node appears on the Ring Map with the other BLSR nodes, then click **OK**.

Step 25 From the View menu, choose **Go to Network View** and verify the following:

- a. Click the **Provisioning > BLSR** tabs. Verify that the new node is displayed under the Node column.
- b. Click the **Alarms** tab. Verify that BLSR alarms such as RING MISMATCH, E-W MISMATCH, PRC-DUPID (duplicate node ID), and APSCDFLTK (default K) are not present.

If the new node does not appear in the Node column, or if BLSR alarms are displayed, log into the new node and verify that the BLSR is provisioned on it correctly with the information from [Steps 8 and 9](#). If the node still does not appear, or if alarms persist, refer to the *Cisco ONS 15327 Troubleshooting Guide*.

Step 26 Click the **Circuits** tab. Wait until all the circuits are discovered. The circuits that pass through the new node will be shown as incomplete.

- Step 27** In network view, right-click the new node and choose **Update Circuits With The New Node** from the shortcut menu. Verify that the number of updated circuits displayed in the dialog box is correct.
- Step 28** If incomplete circuits still appear, refer to the *Cisco ONS 15327 Troubleshooting Guide*.
- Step 29** Click the **History** tab. Verify that BLSR_RESYNC conditions are present for every node in the BLSR.
- Step 30** Complete the “[DLP-B194 Clear a BLSR Force Ring Switch](#)” task on page 13-8 to remove the ring switch from the east and west BLSR lines.
- Step 31** (Optional) Complete the “[NTP-B175 BLSR Acceptance Test](#)” procedure on page 4-16.
- Stop. You have completed this procedure.**
-

DLP-B302 Check BLSR or Path Protection Alarms and Conditions

Purpose	Use this task to check a BLSR or a path protection for alarms and conditions before performing any major change to the ring such as adding and removing nodes.
Tools/Equipment	None
Prerequisite Procedures	DLP-B60 Log into CTC , page 2-23
Required/As Needed	As needed
Onsite/Remote	Onsite
Security Level	Provisioning or higher

- Step 1** From the View menu choose **Go to Network View**. Verify that all BLSR or path protection spans on the network map are green.
- Step 2** Click the **Alarms** tab. Verify that no critical or major alarms are present, nor any facility alarms, such as LOS, LOF, AIS-L, SF, and SD. In a BLSR, these facility conditions might be reported as minor alarms. Make sure the Filter button in the lower right corner of the window is off (not indented).
- Step 3** Click the **Conditions** tab and click **Retrieve Conditions**. Verify that no ring switches are active. Make sure the Filter button in the lower right corner of the window is off (not indented).
- Step 4** Return to the originating procedure (NTP).
-

DLP-B242 Create a BLSR on a Single Node

Purpose	Use this task to create a BLSR on a single node. The task is used when you add a node to an existing BLSR or when you delete and then recreate a BLSR temporarily on one node.
Tools/Equipment	None
Prerequisite Procedures	DLP-B60 Log into CTC , page 2-23
Required/As Needed	As needed
Onsite/Remote	Onsite
Security Level	Provisioning or higher

-
- Step 1** In node view, lick the **Maintenance > BLSR** tabs.
- Step 2** In the Suggestion dialog box, click **OK**.
- Step 3** In the Create BLSR dialog box, enter the BLSR information:
- Ring Type—Enter **2 Fiber**. You cannot provision 4-Fiber BLSRs on ONS 15327s.
 - Ring ID—Enter the BLSR ring ID. If the node is being added to a BLSR, use the BLSR ring ID.
 - Node ID—Enter the node ID. If the node is being added to a BLSR, use an ID that is not used by other BLSR nodes.
 - Ring Reversion—Enter the ring reversion time of the existing BLSR.
 - West Line—Enter the slot on the node that will connect to the existing BLSR via the node's west line.
 - East Line—Enter the slot on the node that will connect to the existing BLSR via the node's east line.
- Step 4** Click **OK**.
-  **Note** Alarms are displayed and the BLSR is displayed as Incomplete until the node is connected to other BLSR nodes.
-
- Step 5** Return to your originating procedure (NTP).
-

DLP-B303 Initiate a BLSR Force Ring Switch

Purpose	Use this task to perform a BLSR Force protection operation on a BLSR port.
Tools/Equipment	None
Prerequisite Procedures	DLP-B60 Log into CTC, page 2-23
Required/As Needed	As needed
Onsite/Remote	Onsite
Security Level	Provisioning or higher

 **Caution** Traffic is not protected during a Force protection switch.

 **Note** A Force switch request on a span or card causes CTC to raise a FORCED-REQ condition. It is informational only; the condition will clear when the force switch command is cleared.

-
- Step 1** From the View menu, choose **Go to Network View**.
- Step 2** the **Provisioning > BLSR** tabs.
- Step 3** Click **Edit**.

Step 4 To apply a Force switch to the west line:

- a. Right-click the west BLSR port where you want to switch the BLSR traffic and choose **Set West Protection Operation**.



Note If node icons overlap, drag and drop the icons to a new location or return to network view and change the positions of the network node icons, because BLSR node icons are based on the network view node icon positions.



Note For two-fiber BLSRs, the squares on the node icons represent the BLSR working and protect channels. You can right-click either channel. For four-fiber BLSRs, the squares represent ports. Right-click either working port.

- b. In the Set West Protection Operation dialog box, choose **FORCE RING** from the pull-down menu. Click **OK**.
- c. Click **Yes** in the two Confirm BLSR Operation dialog boxes that appear.

On the network graphic, an F appears on the working BLSR channel where you invoked the protection switch. The span lines change color to reflect the forced traffic. Green span lines indicate the new BLSR path, and the lines between the protection switch are purple.

Performing a Force switch generates several conditions including FORCED-REQ-RING, FORCED-REQ-RING, and WKSWPR.

Step 5 To apply a Force switch to the east line:

- a. Right-click the east BLSR port and choose **Set East Protection Operation**.



Note If node icons overlap, drag and drop the icons to a new location or return to network view and change the positions of the network node icons, because BLSR node icons are based on the network view node icon positions.



Note The squares on the node icons represent the BLSR working and protect channels. You can right-click either channel.

- b. In the Set East Protection Operation dialog box, choose **FORCE RING** from the pull-down menu. Click **OK**.
- c. Click **Yes** in the two Confirm BLSR Operation dialog boxes that appear.

On the network graphic, an F appears on the working BLSR channel where you invoked the protection switch. The span lines change color to reflect the forced traffic. Green span lines indicate the new BLSR path, and the lines between the protection switch are purple.

Performing a Force switch generates several conditions including FORCED-REQ-RING, FORCED-REQ-RING, and WKSWPR.

Step 6 From the File menu, choose **Close**.

Step 7 Return to your originating procedure (NTP).

DLP-B194 Clear a BLSR Force Ring Switch

Purpose	Use this task to remove a BLSR Force ring switch.
Tools/Equipment	None
Prerequisite Procedures	DLP-B60 Log into CTC, page 2-23
Required/As Needed	As needed
Onsite/Remote	Onsite
Security Level	Provisioning or higher

-
- Step 1** From the node view choose **Go to Network View**.
- Step 2** Click the **Provisioning > BLSR** tabs.
- Step 3** Click **Edit**.
- Step 4** To clear a Force switch on the west line:
- Right-click the BLSR west port where you want to clear the protection switch and choose **Set West Protection Operation**. Ports with a Force switch applied are marked with an F.
 - In the Set West Protection Operation dialog box, choose **CLEAR** from the pull-down menu. Click **OK**.
 - In the Confirm BLSR Operation dialog box, click **Yes**.
- Step 5** To clear a Force switch on the east line:
- Right-click the BLSR east port where you want to clear the protection switch and choose **Set East Protection Operation**. Ports with a Force switch applied are marked with an F.
 - In the Set East Protection Operation dialog box, choose **CLEAR** from the pull-down menu. Click **OK**.
 - In the Confirm BLSR Operation dialog box, click **Yes**.
- On the BLSR network graphic, a green and a purple span line connects each node. This is the normal display for BLSR spans when a protection switch is not present.
- Step 6** From the File menu, choose **Close**.
- Step 7** Return to your originating procedure (NTP).
-

NTP-B213 Remove a BLSR Node

Purpose	This procedure removes a node from a BLSR.
Tools/Equipment	None
Prerequisite Procedures	NTP-108 Back Up the Database, page 14-6
Required/As Needed	As needed
Onsite/Remote	Onsite
Security Level	Provisioning or higher

**Caution**

The following procedure minimizes traffic outages during node removals. You will delete all circuits that originate and terminate on the node that will be removed.

**Caution**

If you remove a node that is the only BITS timing source for the ring, you also remove the only source of synchronization for all the nodes in that ring. Circuits that leave the ring to connect to other networks synchronized to a Stratum 1 clock will experience a high level of pointer adjustments, which might adversely affect traffic performance.

Step 1

Log into a node on the BLSR. Do not log into the node that you will remove. See the “[DLP-B60 Log into CTC](#)” task on page 2-23 for instructions.

Step 2

Create a diagram of the BLSR where you will remove the node. You can draw the BLSR manually, or print it from CTC by performing the following steps:

- a. From the View menu, choose **Go to Network View**.
- b. Click the **BLSR** tab, click the BLSR, then click **Edit**.
- c. In the BLSR window, verify that all the port information is visible. If not, press **Ctrl** and drag the node icons to a new location so the information can be viewed.
- d. From the File menu, choose **Print**.
- e. Close the BLSR window by choosing **Close** from the File menu.

Step 3

Referring to the BLSR diagram, identify the following:

- The node that is connected through its west port to the node that will be removed. For example, if you were removing Node 3 in Figure 13-2, Node 1 is the node connected through its west port to Node 3.
- The node that is connected via its east port to the target (removed) node. In Figure 13-2, Node 3 is the node connected via its east port to Node 4.

Figure 13-2 Four-Node, Two-Fiber BLSR Before a Node Is Removed

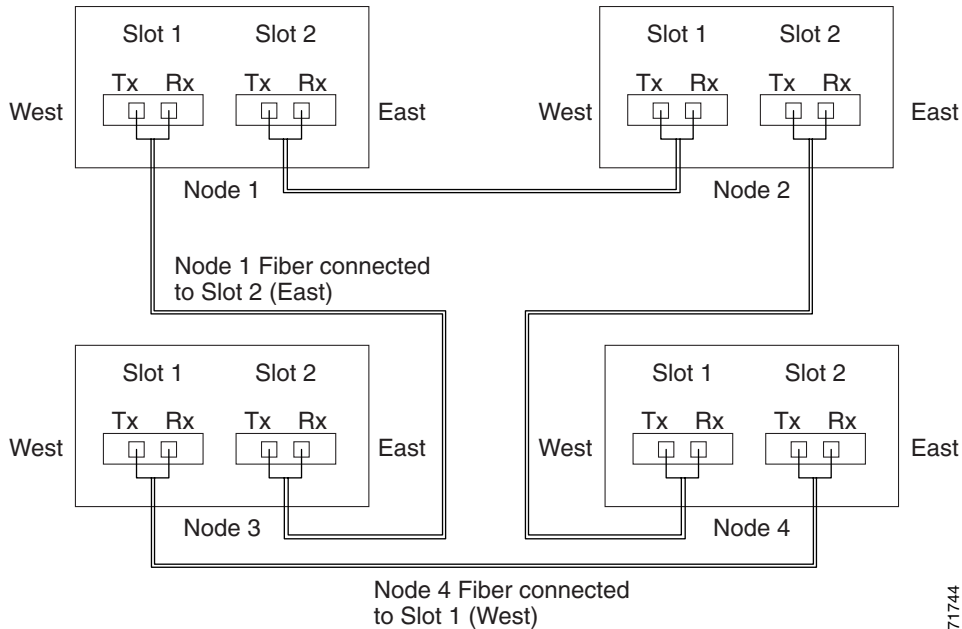

71744

- Step 4** Complete the “[DLP-B302 Check BLSR or Path Protection Alarms and Conditions](#)” task on page 13-5 to verify that the BLSR is free of alarms. If trouble is indicated (for example, a major alarm exists), resolve the problem before proceeding. See [Chapter 6, “Manage Alarms”](#) or, if necessary, refer to the *Cisco ONS 15327 Troubleshooting Guide*.
- Step 5** From the View menu choose **Go to Other Node**. Choose the node that you will remove and click **OK**.
- Step 6** Click the **Circuits** tab. If the Scope setting is set to Network, choose **Node** from the Scope pull-down menu. Make sure the Filter button is off (not indented) to ensure that all circuits are visible.
- Step 7** Delete all circuits that originate or terminate on the node. See the “[NTP-B152 Delete Circuits](#)” procedure on page 8-18.
- Step 8** Complete the “[DLP-B304 Verify BLSR Pass-Through Circuits](#)” task on page 13-11 to verify that circuits passing through the target node enter and exit the node on the same STS and/or VT.
- Step 9** From the View menu choose **Go to Network View**.
- Step 10** Referring to the diagram created in [Step 1](#), complete the “[DLP-B303 Initiate a BLSR Force Ring Switch](#)” task on page 13-6 at each node that connects to the target node to force traffic away from the target node. You must perform a Force switch at each port connected to the target node. For example, in [Figure 13-2](#), you would perform a Force switch on the east port of Node 4 and the west port of Node 1.
- Step 11** Click the **Alarms** tab. If unexpected critical or major alarms are present, resolve them before you continue. If necessary, refer to the alarm troubleshooting procedures in the *Cisco ONS 15327 Troubleshooting Guide*.
- Step 12** Remove the fiber connections between the target node and the two neighboring nodes.
- Step 13** Reconnect the fiber of the two neighboring nodes directly, west port to east port.
- Step 14** On the removed node, complete the “[DLP-B196 Delete a BLSR from a Single Node](#)” task on page 13-12 to remove the BLSR from the former BLSR trunk card.



Note If you delete a node that was in a login node group, you will see incomplete circuits for that node in the CTC network view. (Although it is no longer part of the ring, the removed node still reports to CTC until it is no longer in a login node group.)

- Step 15** Click the **History** tab. Verify that the BLSR_RESYNC condition is present for every node in the BLSR.
- Step 16** Complete the “[DLP-B194 Clear a BLSR Force Ring Switch](#)” task on page 13-8 for both switches.
- Step 17** Complete the “[DLP-B195 Verify Timing in a Reduced Ring](#)” task on page 13-12.
- Step 18** (Optional) Complete the “[NTP-B175 BLSR Acceptance Test](#)” procedure on page 4-16.
- Stop. You have completed this procedure.**

DLP-B304 Verify BLSR Pass-Through Circuits

Purpose	Use this task to verify that circuits passing through a node that will be removed from a BLSR enter and exit the node on the same STS and/or VT.
Tools/Equipment	None
Prerequisite Procedures	DLP-B60 Log into CTC , page 2-23
Required/As Needed	As needed
Onsite/Remote	Onsite or remote
Security Level	Provisioning or higher

- Step 1** On the CTC Circuits window, choose a circuit that passes through the target BLSR node and click **Edit**.
- Step 2** In the Edit Circuits window, check **Show Detailed Map**.
- Step 3** Verify that the STS and VT mapping on the node’s east and west ports are the same. For example, if a circuit mapping on the west port s5/p1/S1 (Slot 5, Port 1, STS 1), verify that the mapping is STS 1 on the east port. If the circuit appears different STSs and/or VTs on the east and west ports, write down the name of the circuit.
- Step 4** Repeat Steps 1 through 3 for each circuit displayed in the Circuits tab.
- Delete and recreate each circuit recorded in Step 3 that entered/exited the node on different STSs. To delete the circuit, complete the “[NTP-B152 Delete Circuits](#)” procedure on page 8-18. To create circuits, complete the appropriate procedures in Chapter 5, “[Create Circuits and VT Tunnels](#).”
- Step 5** Return to your originating procedure (NTP).

DLP-B195 Verify Timing in a Reduced Ring

Purpose	Use this task to verify timing in the ring where you removed a node.
Tools/Equipment	None
Prerequisite Procedures	NTP-B213 Remove a BLSR Node, page 13-8 or NTP-B106 Remove a Path Protection Node, page 13-15
Required/As Needed	As needed
Onsite/Remote	Onsite or remote
Security Level	Provisioning or higher

-
- Step 1** In node view, click the **Provisioning > Timing** tabs.
- Step 2** Identify the type of timing (Line, External, Mixed) in the Timing Mode field.
- Step 3** Scroll down to the Reference Lists and observe the NE Reference fields to see the timing references provisioned for that node.
- Step 4** If the removed node was the only BITS timing source, perform the following:
- Look for another node on the ring that can be used as a BITS source and set that node's Timing Mode to **External**. Choose that node as the primary timing source for all other nodes in the ring. See the "[DLP-B157 Change the Node Timing Source](#)" task on page 9-15.
 - If no node in the reduced ring can be used as a BITS source, choose one node to be your internal timing source. Set that node's Timing Mode to **External**, set the BITS 1 and 2 State field to **OOS**, and set the NE Reference to **Internal Clock**. Then, choose line timing for all other nodes in the ring. This forces the first node to be their primary timing source. See the "[DLP-B157 Change the Node Timing Source](#)" task on page 9-15.
-  **Note** Internal timing conforms to Stratum 3 requirements and is not considered optimal.
-
- Step 5** If the removed node was not the only BITS timing source, provision the adjacent nodes to line timing using SONET links (east and west) as timing sources, traceable to the node with external BITS timing. See the "[NTP-B28 Set Up Timing](#)" procedure on page 3-17.
- Step 6** Return to your originating procedure (NTP).
-

DLP-B196 Delete a BLSR from a Single Node

Purpose	Use this task to delete a BLSR from a node after you remove the node from the BLSR.
Tools/Equipment	None
Prerequisite Procedures	DLP-B60 Log into CTC, page 2-23
Required/As Needed	As needed
Onsite/Remote	Onsite or remote
Security Level	Provisioning or higher

-
- Step 1** In node view, display the node that was removed from the BLSR.
- Step 2** Click the **Provisioning > BLSR** tabs.
- Step 3** Highlight the ring and click **Delete**.
- Step 4** In the Suggestion dialog box, click **OK**.
- Step 5** In the confirmation message, confirm that this is the ring you want to delete. If so, click **Yes**.
- Step 6** Return to your originating procedure (NTP).
-

NTP-B105 Add a Path Protection Node

Purpose	This procedure adds a node to a path protection.
Tools/Equipment	None
Prerequisite Procedures	Cards must be installed and node turnup procedures completed on the node that will be added to the path protection. See Chapter 1, “Install Hardware,” and Chapter 3, “Turn Up Node.” NTP-108 Back Up the Database, page 14-6
Required/As Needed	As needed
Onsite/Remote	Onsite
Security Level	Provisioning or higher

-
- Step 1** Verify the card installation on the new node. See the [“NTP-B24 Verify Card Installation” procedure on page 3-2.](#)
- Step 2** Verify that the OC-N cards that will serve as the path protection trunk (span) cards match the path protection optical rate of the trunk cards to which the new node will be connected. For example, if the adjacent nodes have OC-48 line cards, the new node must have OC-48 cards installed. If the OC-N cards are not installed or the rate does not match the rate of the adjacent node trunk cards, complete the [“NTP-B218 Install the Optical and Ethernet Cards” procedure on page 1-23](#) to install them.
- Step 3** Verify that fiber is available to connect the new node to the existing nodes.
- Step 4** Complete the [“NTP-B35 Verify Node Turn Up” procedure on page 4-2.](#)
- Step 5** Log into a node in the path protection where you want to add a node. See the [“DLP-B60 Log into CTC” task on page 2-23](#) for instructions. In order to have CTC visibility to the new node after it is added, you must be an authorized user on the node and you must have IP connectivity to the node.
- Step 6** Complete the [“DLP-B302 Check BLSR or Path Protection Alarms and Conditions” task on page 13-5](#) to verify that the path protection is free of major alarms or problems. If trouble is indicated (for example, a major alarm exists), resolve the problem before proceeding. See [Chapter 6, “Manage Alarms”](#) or, if necessary, refer to the *Cisco ONS 15327 Troubleshooting Guide*.
- Step 7** Log into the new node:
- If the node has a LAN connection and appears on the network map, from the View menu, choose **Go to Other Node**, then choose the new node from the Select Node to Go to pull-down menu on the Select Node dialog box and click **OK**.

- If the new node is not connected to the network, log into it directly using the “DLP-B60 Log into CTC” task on page 2-23.
- Step 8** Click the **Alarms** tab. Verify that no critical or major alarms are present, nor any facility alarms, such as LOS, LOF, AIS-L, SF, and SD. If trouble is indicated (for example, a major alarm exists), resolve the problem before proceeding. See Chapter 6, “Manage Alarms” or, if necessary, refer to the *Cisco ONS 15327 Troubleshooting Guide*.
- Step 9** Complete the following steps if the node is on the same subnet as other path protection nodes, it is not provisioned as an external network element (see “NTP-B169 Set Up CTC Network Access” procedure on page 3-7), and a CTC computer will directly connect to the node while other CTC computers are directly connected to other path protection nodes. If not, continue with Step 10.
- a. Click the **Provisioning > Network > General** tabs. View the IP Address and Net/Subnet Mask Length fields to verify the node is on the same subnet as other path protection nodes.
 - b. Click the **Static Route** tab and click **Create**.
 - c. In the Create Static Route dialog box, enter the following settings:
 - Destination IP address: *Local PC IP address*
 - Net Mask: **255.255.255.255**
 - Next Hop: *IP address of the Cisco ONS 15327*
 - Cost: **1**
 - d. Click **OK**.
- Step 10** (Optional) Create test circuits, making sure they pass through the path protection line cards, and run test traffic through the node to ensure the cards are functioning properly. See the “NTP-B189 Create a Manually Routed OC-N Circuit” procedure on page 5-44 and the “NTP-B62 Test OC-N Circuits” procedure on page 5-52 for information.
- Step 11** Create the DCC terminations on the new node. See the “DLP-B253 Provision SONET DCC Terminations” task on page 4-5.
- Step 12** From the View menu, choose **Go to Network View**.
- Step 13** Complete the “DLP-B197 Initiate a Path Protection Force Switch” task on page 13-16 to switch traffic away from the span that will be broken to connect to the new node.



Caution Traffic is not protected during a protection switch.

- Step 14** Two nodes will connect directly to the new node; remove their fiber connections:
- a. Remove the east fiber connection from the node that will connect to the west port of the new node.
 - b. Remove the west fiber connection from the node that will connect to the east port of the new node.
- Step 15** Replace the removed fibers with the fibers that are connected to the new node.
- Step 16** Log out of CTC and log back into a node in the network.
- Step 17** From the View menu, choose **Go to Network View** to display the path protection nodes. The new node should appear in the network map. Wait for a few minutes to allow all the nodes to appear.
- Step 18** Click the **Circuits** tab and wait for all the circuits to appear, including spans. Count the number of incomplete circuits.
- Step 19** In the network view, right-click the new node and choose **Update Circuits With New Node** from the list of options. Wait for the confirmation dialog box to appear. Verify that the number of updated circuits in the dialog box is correct.

- Step 20** Click the **Circuits** tab and verify that no incomplete circuits appear.
- Step 21** Complete the “[DLP-B198 Clear a Path Protection Switch](#)” task on page 13-17.
- Step 22** (Optional) Complete the “[NTP-B177 Path Protection Acceptance Test](#)” procedure on page 4-23.
- Stop. You have completed this procedure.**

NTP-B106 Remove a Path Protection Node

Purpose	This procedure removes a node from a path protection.
Tools/Equipment	None
Prerequisite Procedures	NTP-108 Back Up the Database , page 14-6
Required/As Needed	As needed
Onsite/Remote	Onsite
Security Level	Provisioning or higher



Caution

The following procedure minimizes traffic outages during node removals.



Caution

If you remove a node that is the only BITS timing source for the ring, you also remove the only source of synchronization for all the nodes in that ring. Circuits that connect to other networks which are synchronized to a Stratum 1 clock will experience a high level of pointer adjustments, which might adversely affect customer service.

- Step 1** Draw a diagram of the path protection where you will remove the node. In the diagram, identify the following:
- The node that is connected through its west port to the node that will be removed (the target node).
 - The node that is connected through its east port to the target node.
- Step 2** Log into a node in the network where you want to remove a path protection node. See the “[DLP-B60 Log into CTC](#)” task on page 2-23 for instructions.
- Step 3** Complete the “[DLP-B302 Check BLSR or Path Protection Alarms and Conditions](#)” task on page 13-5 to verify that the path protection is free of alarms. If trouble is indicated (for example, a major alarm exists), resolve the problem before proceeding. See [Chapter 6, “Manage Alarms”](#) or, if necessary, refer to the *Cisco ONS 15327 Troubleshooting Guide*.
- Step 4** Complete the “[NTP-B152 Delete Circuits](#)” procedure on page 8-18 for circuits that originate or terminate in the target node. (If a circuit has multiple drops, delete only the drops that terminate on the node you are deleting.)
- Step 5** Complete the “[DLP-B197 Initiate a Path Protection Force Switch](#)” task on page 13-16 for all spans connected to the node you are removing.



Caution

Traffic is not protected during a forced protection switch.

- Step 6** Remove all fiber connections between the target node and the two neighboring nodes.

Step 7 Reconnect the fiber of the two neighboring nodes directly, west port to east port.



Note If you delete a node that was in a login node group, you will see incomplete circuits for that node in CTC network view. (Although it is no longer part of the ring, the removed node still reports to CTC until it is no longer in a login node group.)

Step 8 Exit CTC and log back in. See the “[DLP-B60 Log into CTC](#)” task on page 2-23 for instructions.

Step 9 Log into each newly-connected node and open the **Alarms** tab. Verify that the trunk cards are free of alarms. Resolve any alarms before proceeding. Refer to the *Cisco ONS 15327 Troubleshooting Guide*.

Step 10 Complete the “[DLP-B195 Verify Timing in a Reduced Ring](#)” task on page 13-12.

Step 11 Complete the “[DLP-B198 Clear a Path Protection Switch](#)” task on page 13-17.

Step 12 Click the **Circuits** tab and verify that no incomplete circuits are present.

Step 13 (Optional) Complete the “[NTP-B177 Path Protection Acceptance Test](#)” procedure on page 4-23.

Stop. You have completed this procedure.

DLP-B197 Initiate a Path Protection Force Switch

Purpose	Use this task to switch all circuits on a path protection span to another span.
Tools/Equipment	None
Prerequisite Procedures	DLP-B60 Log into CTC , page 2-23
Required/As Needed	As needed
Onsite/Remote	Onsite or remote
Security Level	Provisioning or higher



Caution Traffic is not protected during Force path protection switches.

Step 1 From the View menu choose **Go to Network View**.

Step 2 Right-click the span where you want to Force switch path protection traffic. Choose **Circuits** from the shortcut menu.

Step 3 In the Circuits on Span dialog box, choose **FORCE SWITCH AWAY**. Click **Apply**.

Step 4 In the Confirm Path Protection Switch dialog box, click **Yes**.

Step 5 In the Protection Switch Result dialog box, click **OK**.

In the Circuits on Span window, the Switch State for all circuits is Force. [Figure 13-3](#) shows an example.

Figure 13-3 Circuits on Span Dialog Box with a Force Switch

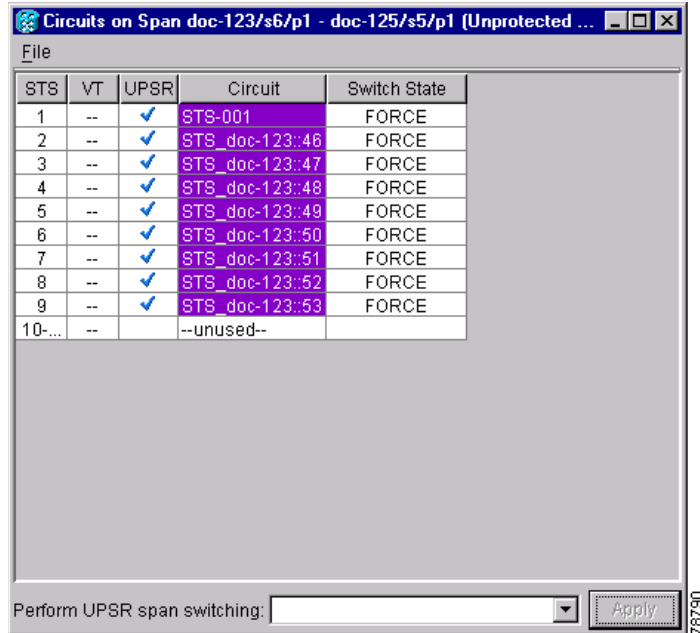

Note A Force switch request on a span or card causes CTC to raise a FORCED-REQ condition. The condition clears when you clear the Force switch; it is informational only.

Step 6 Return to your originating procedure (NTP).

DLP-B198 Clear a Path Protection Switch

Purpose	Use this task to clear a Path Protection Force switch.
Tools/Equipment	None
Prerequisite Procedures	DLP-B60 Log into CTC, page 2-23
Required/As Needed	As needed
Onsite/Remote	Onsite or remote
Security Level	Provisioning or higher

- Step 1** From the View menu, choose **Go to Network View**.
- Step 2** Right-click the span where you want to clear the switch. Choose **Circuits** from the shortcut menu.
- Step 3** In the Circuits on Span dialog box, choose **CLEAR** to remove the switch. Click **Apply**.
- Step 4** In the Confirm Path Protection Switch dialog box, click **Yes**.
- Step 5** In the Protection Switch Result dialog box, click **OK**.
- In the Circuits on Span window, the Switch State for all path protection circuits is CLEAR.

Step 6 Return to your originating procedure (NTP).
