



Cisco Voice Services Provisioning Tool User's Guide

Release 2.3(1)
September, 2002

Corporate Headquarters

Cisco Systems, Inc.
170 West Tasman Drive
San Jose, CA 95134-1706
USA
<http://www.cisco.com>
Tel: 408 526-4000
800 553-NETS (6387)
Fax: 408 526-4100

Text Part Number: OL-1910-01



THE SPECIFICATIONS AND INFORMATION REGARDING THE PRODUCTS IN THIS MANUAL ARE SUBJECT TO CHANGE WITHOUT NOTICE. ALL STATEMENTS, INFORMATION, AND RECOMMENDATIONS IN THIS MANUAL ARE BELIEVED TO BE ACCURATE BUT ARE PRESENTED WITHOUT WARRANTY OF ANY KIND, EXPRESS OR IMPLIED. USERS MUST TAKE FULL RESPONSIBILITY FOR THEIR APPLICATION OF ANY PRODUCTS.

THE SOFTWARE LICENSE AND LIMITED WARRANTY FOR THE ACCOMPANYING PRODUCT ARE SET FORTH IN THE INFORMATION PACKET THAT SHIPPED WITH THE PRODUCT AND ARE INCORPORATED HEREIN BY THIS REFERENCE. IF YOU ARE UNABLE TO LOCATE THE SOFTWARE LICENSE OR LIMITED WARRANTY, CONTACT YOUR CISCO REPRESENTATIVE FOR A COPY.

The Cisco implementation of TCP header compression is an adaptation of a program developed by the University of California, Berkeley (UCB) as part of UCB's public domain version of the UNIX operating system. All rights reserved. Copyright © 1981, Regents of the University of California.

NOTWITHSTANDING ANY OTHER WARRANTY HEREIN, ALL DOCUMENT FILES AND SOFTWARE OF THESE SUPPLIERS ARE PROVIDED "AS IS" WITH ALL FAULTS. CISCO AND THE ABOVE-NAMED SUPPLIERS DISCLAIM ALL WARRANTIES, EXPRESSED OR IMPLIED, INCLUDING, WITHOUT LIMITATION, THOSE OF MERCHANTABILITY, FITNESS FOR A PARTICULAR PURPOSE AND NONINFRINGEMENT OR ARISING FROM A COURSE OF DEALING, USAGE, OR TRADE PRACTICE.

IN NO EVENT SHALL CISCO OR ITS SUPPLIERS BE LIABLE FOR ANY INDIRECT, SPECIAL, CONSEQUENTIAL, OR INCIDENTAL DAMAGES, INCLUDING, WITHOUT LIMITATION, LOST PROFITS OR LOSS OR DAMAGE TO DATA ARISING OUT OF THE USE OR INABILITY TO USE THIS MANUAL, EVEN IF CISCO OR ITS SUPPLIERS HAVE BEEN ADVISED OF THE POSSIBILITY OF SUCH DAMAGES.

CCIP, the Cisco *Powered* Network mark, the Cisco Systems Verified logo, Cisco Unity, Fast Step, Follow Me Browsing, FormShare, Internet Quotient, iQ Breakthrough, iQ Expertise, iQ FastTrack, the iQ Logo, iQ Net Readiness Scorecard, Networking Academy, ScriptShare, SMARTnet, TransPath, and Voice LAN are trademarks of Cisco Systems, Inc.; Changing the Way We Work, Live, Play, and Learn, Discover All That's Possible, The Fastest Way to Increase Your Internet Quotient, and iQuick Study are service marks of Cisco Systems, Inc.; and Aironet, ASIST, BPX, Catalyst, CCDA, CCDP, CCIE, CCNA, CCNP, Cisco, the Cisco Certified Internetwork Expert logo, Cisco IOS, the Cisco IOS logo, Cisco Press, Cisco Systems, Cisco Systems Capital, the Cisco Systems logo, Empowering the Internet Generation, Enterprise/Solver, EtherChannel, EtherSwitch, GigaStack, IOS, IP/TV, LightStream, MGX, MICA, the Networkers logo, Network Registrar, *Packet*, PIX, Post-Routing, Pre-Routing, RateMUX, Registrar, SlideCast, StrataView Plus, Stratm, SwitchProbe, TeleRouter, and VCO are registered trademarks of Cisco Systems, Inc. and/or its affiliates in the U.S. and certain other countries.

All other trademarks mentioned in this document or Web site are the property of their respective owners. The use of the word partner does not imply a partnership relationship between Cisco and any other company. (0201R)

Cisco Voice Services Provisioning Tool User's Guide Release 2 3(1)

Copyright © 2001, 2002, Cisco Systems, Inc.

All rights reserved.



Preface vii

Document Objective	vii
Audience	viii
Document Organization	viii
Terminology	viii
Document Conventions	ix
Documentation Suite	ix
Hardware Documentation	ix
Software Installation and Configuration Documentation	ix
Gateway Documentation	ix
Documentation Map	ix
Obtaining Documentation	x
World Wide Web	x
Documentation CD-ROM	xi
Ordering Documentation	xi
Documentation Feedback	xi
Obtaining Technical Assistance	xi
Cisco.com	xii
Technical Assistance Center	xii
Contacting TAC by Using the Cisco TAC Website	xii
Contacting TAC by Telephone	xii
Document Change History	xiii

CHAPTER 1

Voice Services Provisioning Tool Overview 1-1

Provisioning Introduction	1-1
VSPT Introduction	1-2
Installing the VSPT	1-2
Prerequisites	1-5
Preplanning	1-5
Upgrading VSPT Software	1-6
Saving Configuration Files	1-6
Uninstalling the VSPT Software	1-6
Installing the VSPT Software	1-7
VSPT Basics	1-8

- VSPT Field Definitions 1-9
- VSPT Data Entry Requirements 1-10
- Starting the VSPT 1-11
- Using the VSPT 1-11
 - Menu Bar 1-12
 - Buttons 1-13
- Defining Users and Permissions 1-14
- Exiting the VSPT 1-14

CHAPTER 2

- Provisioning with VSPT Wizards 2-1**
 - Starting a New Provisioning Session 2-1
 - Overview of the VSPT Wizards 2-2
 - Using the Tandem Transit with STP Solution Wizard 2-3
 - Configuring the Cisco MGC 2-4
 - Configuring SS7 Signaling Services 2-6
 - Configuring Media Gateway Control Links 2-8
 - Provisioning Session Results 2-10
 - Viewing Generated MML 2-11

CHAPTER 3

- Voice Services Provisioning Tool Utilities 3-1**
 - Perform an Integrity Check 3-1
 - Checking Integrity for MGC Signaling Configuration 3-1
 - Checking Traffic Against MGC Configuration 3-2
 - View Generated MML Commands 3-4
 - View Generated Cisco MGW Commands 3-4
 - Deploy a Configuration 3-5
 - Deploying a New Configuration 3-5
 - Configuring an Incremental Deployment 3-8
 - Telnet 3-9
 - MGC Viewer 3-10
 - State Operation 3-12
 - Perform an Audit 3-13
 - Back Up and Restore 3-15
 - Schedule a Backup or Restore 3-16
 - Check Status of Backup or Restore 3-18
 - Make a Seed File 3-19

INDEX



Preface

This preface describes the objectives, audience, organization, and conventions of this document. It contains the following sections:

- [Document Objective, page vii](#)
- [Audience, page viii](#)
- [Document Organization, page viii](#)
- [Terminology, page viii](#)
- [Document Conventions, page ix](#)
- [Documentation Suite, page ix](#)
- [Obtaining Documentation, page x](#)
- [Obtaining Technical Assistance, page xi](#)
- [Document Change History, page xiii](#)

Document Objective

This document provides the information you need to install, configure, and use the Voice Services Provisioning Tool (VSPT), Release 2.3(1). You should read the system-level documentation supplied with your system before using this guide. A complete list of these documents is included in the *Cisco Media Gateway Controller Software Release 9 Installation and Configuration Guide* that ships with your system.



Note

This document uses the term *media gateway controller software* or *MGC application* to mean the Cisco MGC software that runs in the UNIX environment on a server. The term *MGC* refers to the combination of this software and the server. The Cisco MGC communicates with the SS7 network to process and route calls between a traditional time-division multiplexing (TDM) network and a packet data network. This routing takes place through a variety of media gateways, standalone devices that perform the conversion between the TDM and data network formats.



Note

The Cisco PGW 2200 PSTN Gateway (hereafter referred to as the Cisco PGW 2200) was formerly called the Cisco VSC3000. Some parts of this document might use this older name.

Audience

This document is designed for network operators and administrators who have experience with telecommunications networks, protocols, and equipment and who have familiarity with data communications networks, protocols, and equipment. Software and hardware installers and network designers will also find this document useful.

Document Organization

Table 1 describes the major sections of this document.

Table 1 Document Organization

Chapter	Title	Description
Chapter 1	Voice Services Provisioning Tool Overview	This chapter introduces VSPT, Release 2, and provides directions for obtaining and installing the software. In addition, it provides basic information for using the tool.
Chapter 2	Provisioning with VSPT Wizards	This chapter introduces VSPT wizards and provides an example of configuring a Cisco Media Gateway Controller (MGC) through the use of a wizard.
Chapter 3	Voice Services Provisioning Tool Utilities	This chapter introduces additional tools included with VSPT Release 2 and provides directions for using them.

Terminology

The following terms are used in this document:

Cisco MGC host—A Sun host server running Cisco MGC software. If your product is the Cisco SC2200, this is also known as an SC host. If your product is the Cisco PGW 2200, this is also known as a PSTN Gateway host.

Cisco SC node—The combination of the Cisco SC2200 product and the control signaling network. The SC node consists of all solution components except the media gateway.

Cisco MGC node—The logical grouping of the active and standby MGC hosts, the control signaling network, and the Cisco Signaling Link Terminals (SLTs).

Simplex MGC node—A node that uses a single Cisco MGC host. Typically, nodes of this type are used for solution evaluation tests or for small installations. Any loss of service in the Cisco MGC host disrupts all call traffic. If your product is the Cisco SC2200, this is also called a simplex SC node.

Continuous-service MGC node—A node that uses two Cisco MGC hosts to prevent system downtime that might otherwise result from the failure of a single MGC host. Calls in progress are maintained when one MGC host fails. Continuous-service nodes use SLTs to preprocess SS7 signaling and distribute signaling to both MGC hosts. If a failover occurs, all stable calls are maintained. If your product is the Cisco SC2200, this is also called a continuous-service SC node.

Document Conventions

Notes use the following conventions:



Means *reader be careful*. In this situation, you might do something that could result in equipment damage or loss of data.

**Note**

Means *reader take note*. Notes contain helpful suggestions or references to material not covered in the publication.

Documentation Suite

The following documentation provides information about the Cisco MGC software and the solutions it supports, including the Cisco SS7 Interconnect for Access Servers Solution, the Cisco SS7 Interconnect for Voice Gateways Solution, and the Cisco Packet Tandem Solution.

Hardware Documentation

- *Cisco Media Gateway Controller Hardware Installation Guide*
- *Regulatory Compliance and Safety Information for Cisco Media Gateway Controller Hardware*

Software Installation and Configuration Documentation

- *Cisco Media Gateway Controller Software Release 9 Installation and Configuration Guide*
- *Cisco Media Gateway Controller Software Release 9 Provisioning Guide*
- *Cisco Media Gateway Controller Software Release 9 Dial Plan Guide*
- *Cisco Media Gateway Controller Software Release 9 Operations, Maintenance, and Troubleshooting Guide*
- *Release Notes for the Cisco Media Gateway Controller Software Release 9*
- *Cisco Media Gateway Controller Online Documentation Notice*
- *Cisco Media Gateway Controller SLT Documentation Notice*

Gateway Documentation

Cisco DAS and H.323 VoIP Gateway Installation and Configuration Guide

Documentation Map

[Figure 1](#) shows the sequence in which the various manuals documenting Cisco telephony solutions should be read.

Figure 1 Documentation Map

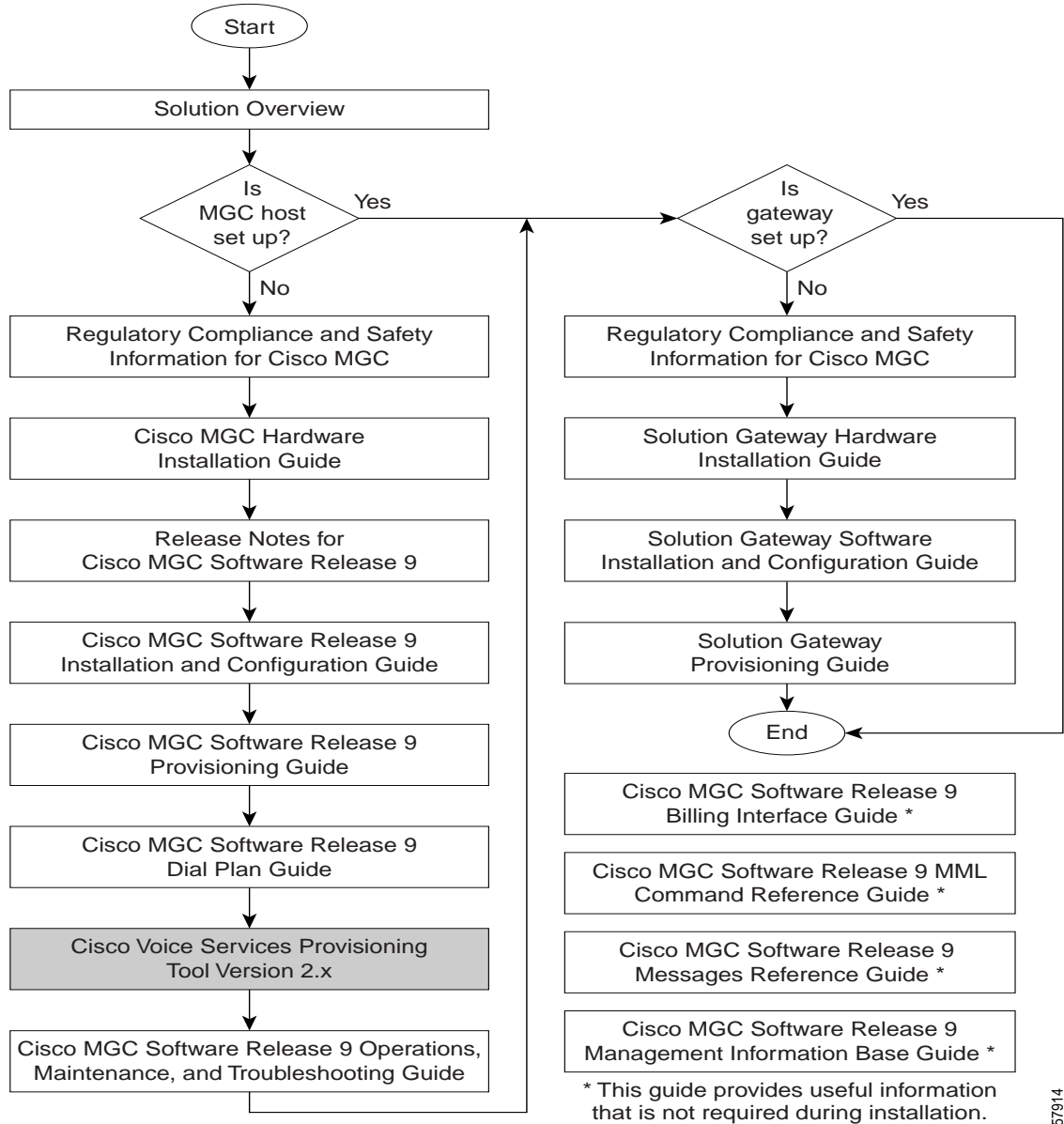

57914

Obtaining Documentation

The following sections provide sources for obtaining documentation from Cisco Systems.

World Wide Web

You can access the most current Cisco documentation on the World Wide Web at the following sites:

- <http://www.cisco.com>

- <http://www-china.cisco.com>
- <http://www-europe.cisco.com>

Documentation CD-ROM

Cisco documentation and additional literature are available in a CD-ROM package, which ships with your product. The Documentation CD-ROM is updated monthly and may be more current than printed documentation. The CD-ROM package is available as a single unit or through an annual subscription.

Ordering Documentation

Cisco documentation is available in the following ways:

- Registered Cisco Direct Customers can order Cisco Product documentation from the Networking Products MarketPlace:
http://www.cisco.com/cgi-bin/order/order_root.pl
- Registered Cisco.com users can order the Documentation CD-ROM through the online Subscription Store:
<http://www.cisco.com/go/subscription>
- Nonregistered Cisco.com users can order documentation through a local account representative by calling Cisco corporate headquarters (California, USA) at 408 526-7208 or, in North America, by calling 800 553-NETS(6387).

Documentation Feedback

If you are reading Cisco product documentation on the World Wide Web, you can submit technical comments electronically. Click **Feedback** in the toolbar and select **Documentation**. After you complete the form, click **Submit** to send it to Cisco.

You can e-mail your comments to bug-doc@cisco.com.

To submit your comments by mail, use the response card behind the front cover of your document, or write to the following address:

Attn Document Resource Connection
Cisco Systems, Inc.
170 West Tasman Drive
San Jose, CA 95134-9883

We appreciate your comments.

Obtaining Technical Assistance

Cisco provides Cisco.com as a starting point for all technical assistance. Customers and partners can obtain documentation, troubleshooting tips, and sample configurations from online tools. For Cisco.com registered users, additional troubleshooting tools are available from the TAC website.

Cisco.com

Cisco.com is the foundation of a suite of interactive, networked services that provides immediate, open access to Cisco information and resources at any time, from anywhere in the world. This highly integrated Internet application is a powerful, easy-to-use tool for doing business with Cisco.

Cisco.com provides a broad range of features and services to help customers and partners streamline business processes and improve productivity. Through Cisco.com, you can find information about Cisco and our networking solutions, services, and programs. In addition, you can resolve technical issues with online technical support, download and test software packages, and order Cisco learning materials and merchandise. Valuable online skill assessment, training, and certification programs are also available.

Customers and partners can self-register on Cisco.com to obtain additional personalized information and services. Registered users can order products, check on the status of an order, access technical support, and view benefits specific to their relationships with Cisco.

To access Cisco.com, go to the following website:

<http://www.cisco.com>

Technical Assistance Center

The Cisco TAC website is available to all customers who need technical assistance with a Cisco product or technology that is under warranty or covered by a maintenance contract.

Contacting TAC by Using the Cisco TAC Website

If you have a priority level 3 (P3) or priority level 4 (P4) problem, contact TAC by going to the TAC website:

<http://www.cisco.com/tac>

P3 and P4 level problems are defined as follows:

- P3—Your network performance is degraded. Network functionality is noticeably impaired, but most business operations continue.
- P4—You need information or assistance on Cisco product capabilities, product installation, or basic product configuration.

In each of the above cases, use the Cisco TAC website to quickly find answers to your questions.

To register for Cisco.com, go to the following website:

<http://www.cisco.com/register/>

If you cannot resolve your technical issue by using the TAC online resources, Cisco.com registered users can open a case online by using the TAC Case Open tool at the following website:

<http://www.cisco.com/tac/caseopen>

Contacting TAC by Telephone

If you have a priority level 1 (P1) or priority level 2 (P2) problem, contact TAC by telephone and immediately open a case. To obtain a directory of toll-free numbers for your country, go to the following website:

<http://www.cisco.com/warp/public/687/Directory/DirTAC.shtml>

P1 and P2 level problems are defined as follows:

- P1—Your production network is down, causing a critical impact to business operations if service is not restored quickly. No workaround is available.
- P2—Your production network is severely degraded, affecting significant aspects of your business operations. No workaround is available.

Document Change History

Table 2 *Change History*

Subject	Document #, Change Date	Change Summary
Updated to document features new in VSPT 2.3	OL-1910-02, July 30, 2002	Updated to document HSI adjunct, 6509 Lan Switch, and integrated SLT.
Initial release	OL-1910-01, February 15, 2002	Initial online release



Voice Services Provisioning Tool Overview

Cisco Open Packet Telephony (OPT) provides the framework for delivering voice services over packet-based data, voice, and video networks. OPT encompasses a broad range of hardware platforms and Cisco software, delivering a continuum of voice solutions from core infrastructure to enhanced services over circuit and packet networks. The Cisco Media Gateway Controller (MGC) is at the center of all Cisco OPT solutions.

Provisioning an MGC is the process of preparing it to communicate with an SS7 network, with Cisco media gateways, and with the other components of an OPT solution. The Cisco Voice Services Provisioning Tool (VSPT) provides an easy-to-use graphical tool to provision Cisco MGCs.

This chapter introduces the VSPT, Release 2, and provides directions for obtaining, installing, and using the software.



Note

Individual releases of the VSPT software is designed to be used with specific releases of the Cisco MGC. If you are using Release 7 of the MGC software, you must use VSPT Release 1.6. Refer to [Table 1-1](#) to select the release of VSPT designed for your version of Cisco MGC software.

This chapter contains the following sections:

- [Provisioning Introduction, page 1-1](#)
- [VSPT Introduction, page 1-2](#)
- [Installing the VSPT, page 1-2](#)
- [VSPT Basics, page 1-8](#)
- [Starting the VSPT, page 1-11](#)
- [Using the VSPT, page 1-11](#)
- [Defining Users and Permissions, page 1-14](#)
- [Exiting the VSPT, page 1-14](#)

Provisioning Introduction

All solutions involving the Cisco MGC are configured through the use of one or more Cisco MGC hosts, one or more Signaling System 7 (SS7) network signaling options, and one or more media gateways that control bearer-traffic routing.

**Note**

In this document, a *solution* is a logical combination of Cisco hardware and software configured to perform a specific network task.

Prior to starting any provisioning session, you should have a clear understanding of the network topology for your solution. Create a network drawing, and refer to it while configuring your network.

In addition, you should perform the following tasks before starting a provisioning session:

- Thoroughly plan your network configuration. Refer to the documentation for your solution for detailed network configuration information.
- Set up your system hardware, and install all required software. For more information, refer to [Prerequisites, page 1-5](#), and the following documents
 - *Cisco Media Gateway Controller Hardware Installation Guide*
 - *Cisco Media Gateway Controller Software Release 9 Installation and Configuration Guide*

VSPT Introduction

The VSPT can be deployed as an integrated component of the Cisco MGC Node Manager or as a standalone application. If it is installed on the Cisco MGC, call throughput might be impacted when the VSPT is active. It typically runs on a standalone UNIX server that is also running the Cisco MGC Node Manager (CMNM) and supports multiple users and provisioning sessions. You can launch the VSPT from the managed object icon in the CMNM map viewer. For information about CMNM, refer to the *CMNM Release 2 User's Guide*.

VSPT allows you to import an existing configuration, modify the configuration, and export it to the same or different devices. Wizards guide you through high-level configuration steps to create the initial network provisioning information for a newly installed node, creating iterative entries from a single operation. VSPT can also facilitate provisioning of individual call parameters, simplifying the provisioning of a large live network.

During a provisioning session, the VSPT automatically generates the Man Machine Language (MML) or command line interface (CLI) scripts used to configure network elements, assembles these commands into a batch file, and deploys the file to the appropriate network device.

**Note**

This document does not include instructions for dial plan provisioning. For dial plan information, refer to the *Cisco Media Gateway Controller Software Release 9 Dial Plan Guide*.

Installing the VSPT

If you are a registered Cisco.com user, you can download the VSPT software from the Cisco web site. You must install the VSPT release that is compatible with your Cisco MGC software. Refer to [Table 1-1](#) for a guide to Cisco MGC and VSPT software release compatibility.

Table 1-1 VSPT & Cisco MGC Software Release Compatibility

VSPT Software Release	Cisco MGC Software Release	BAMS Software Release	New Features Added
VSPT 2.3(1)	Cisco MGC Release 9.3(1)	BAMs Phase 2, BAMS Phase 3 (3.10)	<ul style="list-style-type: none"> • Backup and restore of the HSI adjunct • VISM 2.2 and 3.0 Support • Backup and restore of the Catalyst 6509 when used as the PGW node's LAN switch • Support new result types • New, internally generated cause codes exported in the PGW2200 dial plan
VSPT 2.2(2)	Cisco MGC Release 9.2(1.5-2)	BAMs Phase 2, BAMS Phase 3	
VSPT 2.2(2A)	Cisco MGC Release 9.2(1.5)	BAMs Phase 2, BAMS Phase 3	<ul style="list-style-type: none"> • Removal of support for TDM cards, (ITK, V.35) cards. • Support for BAMS Phase 3
VSPT 2.2(1C)	Cisco MGC Release 9.2(0-1)T	BAMs Phase 2, BAMS Phase 3	<ul style="list-style-type: none"> • Backup and restore MGC system files. • Netscape browser. • Screening editor to create and modify screening files. • Multiple provisioning sessions. • Online help
VSPT 2.1(4)	Cisco MGC Release 9.1(5)	BAMs Phase 2, BAMS Phase 3 (3.08)	<ul style="list-style-type: none"> • Support for multiple dial plans. • Provisioning Advice of Charge
VSPT 2.1(2.A)XA	Cisco MGC Release 9.1(3.4)XA	BAMs Phase 2, BAMS Phase 3 (3.08)	

Table 1-1 VSPT & Cisco MGC Software Release Compatibility

VSPT Software Release	Cisco MGC Software Release	BAMS Software Release	New Features Added
VSPT 2.1(2.B)	Cisco MGC Release 9.1(3.0-9)T	BAMs Phase 2, BAMS Phase 3 (3.08)	
VSPT 2.0			<ul style="list-style-type: none"> • State Operations Utility • CAS signaling paths provisioning • Define trunk group profiles • Automatic Congestion Control provisioning • Define SIP signaling paths, SIP IP Links, and SIP trunk groups, and support for SIP routes • Support for multiple OPCs

Before installing the VSPT, you must verify the following:

- You have the appropriate release of the VSPT software. Visit the following Cisco web site to check the VSPT release number (a valid login to the VSPT Cisco web site is required):

<http://www.cisco.com> > Software Center > Voice Software > Cisco Voice Services Provisioning Tool

- You have met the workstation hardware and software requirements. Refer to the Release Notes for your release of the Cisco MGC Release 9 and VSPT Release 2 software for a complete list of hardware requirements.
- You have established network connectivity between your workstation and the network elements.
- The network elements have the correct release of software installed.

**Note**

Make sure you have root access on your Sun workstation.

**Tip**

Before you begin provisioning, you should have a list of components you want to provision, including the component names, IP addresses, properties, and other parameters. To create this list, use the instructions provided in the *Cisco Media Gateway Controller Software Release 9 Provisioning Guide*. In addition, descriptions of the properties and values contained in the VSPT are included in Appendix A of the *Cisco Media Gateway Controller Software Release 9 Provisioning Guide* and in the following chapters. Review this information before you begin provisioning, and keep it available for reference during provisioning.

Prerequisites

To install the VSPT software, you must have at least the following:

- Sun SPARCstation running Solaris Version 2.8 or earlier
- Sun Ultra-5 workstation (333 MHz or faster)
- Sun Solaris 2.6 or later
- Open Windows with the Common Desktop Environment
- Latest Solaris 2.8 recommend patch set (log in to <http://sunsolve.sun.com> and click on **Patches**)
- Cisco Media Gateway Controller software Release 9.x
- 8-bit video graphics card
- Disk space:
 - Approximately 20 MB of disk space for installation
 - Directory `/var/opt/data/`:
 - Approximately 1 MB for each configuration
 - Approximately 1 MB for each configuration snapshot
 - Directory `/var/opt/log/`:
 - Approximately 0.5 MB for each deployment
- RAM:
 - Minimum: 128 MB
 - Recommended: 256 MB or greater
- Swap space:
 - Minimum: 128 MB
 - Recommended: 256 MB or greater

**Note**

Running the VSPT on the same host as the Cisco MGC can adversely affect performance. We recommend using a standalone server.

**Note**

The VSPT may also be installed on the same server as the Cisco MGC Node Manager client. It adds no additional hardware requirements in this configuration.

Preplanning

VSPT supports multiple solutions and offers the option to provision components for these solutions. Some components might not apply to your solution. Make sure you understand your solution component requirements. For information, refer to the provisioning guide for your solution.

Upgrading VSPT Software

If you have a previous release of the VSPT installed (such as VSPT Release 2.0 and you are performing a minor upgrade to VSPT Release 2.3), the existing VSPT network configuration data is automatically moved to VSPT Release 2.3. However, if a major earlier release is detected during the upgrade, (such as VSPT Release 1.6) and you are upgrading to VSPT Release 2, the existing VSPT network configuration data is not formatted for use with VSPT Release 2 and is not moved.

Two versions of the VSPT (such as VSPT 1.6 and 2) can exist on the same system; when you are upgrading, the older version is not automatically removed and must be manually uninstalled if you want to remove it. See the “[Uninstalling the VSPT Software](#)” section on page 1-6 for information.



Note

Since the uninstall directory and files are removed during uninstall, **do not** change to the /opt/CSCO2X directory to run the uninstall script.

Saving Configuration Files

Before uninstalling the VSPT software, you can save current configuration data and administrative information so users and logins do not need to be recreated after the upgrade. Use the following procedure to save data and user information:

-
- Step 1** Log in to the server as root.
 - Step 2** Create a temporary directory to hold the pertinent files.
 - Step 3** Use the following command to copy the password file, /var/opt/CSCOVspXX/etc/dartpwd.txt, to the temporary directory:

```
# cp -p /var/opt/CSCOVspXX/etc/dartpwd.txt /<temporary directory>/dartpwd.txt
```
 - Step 4** Change to the /var/opt/CSCOVspXX/data directory.
 - Step 5** Use the **tar** command to archive all files in the directory.



Note

The **tar** command preserves file permissions.

- Step 6** Copy the archive file to the temporary directory.
-

After you upgrade the VSPT software, replace the /var/opt/CSCOVsp<New>/etc/dartpwd.txt file and the /var/opt/CSCOVsp<New>/data directory with the archive files you saved in the temporary directory.

Uninstalling the VSPT Software

The uninstallation process removes the /var/opt/<CSCOVspt2x> directory created by the installation process. If a directory contains a file that was not created during the installation process, it is not removed and is logged in the uninstall.log file. This might occur in the data and logs directories, and all application data stored in the /var/opt/<CSCOVsp2x> directory will not be deleted.

Use the following procedure to uninstall the software:

-
- Step 1** Enter the following commands:
- ```
>su -root
>cd /
>/opt/CSCO2x/uninstall/uninstall
```
- Step 2** Proceed with the VSPT software installation (see “Installing the VSPT Software” section on page 1-7).
- 

## Installing the VSPT Software

To install the software from the Cisco web site, follow this procedure:

- 
- Step 1** Verify that the requirements listed in the “Prerequisites” section on page 1-5 have been met.
- Step 2** Become the root user by entering the following command:
- ```
>su - root
```
- Step 3** Create the temporary directory /var/tmp/CSCOVsp23-install by entering the following command:
- ```
#mkdir -p /var/tmp/CSCOVsp23-install
```
- Step 4** Open a web browser and browse to the following site:
- ```
http://www.cisco.com> Software Center > Network Management> Cisco Voice Services Provisioning Tool
```
- Step 5** Select the desired release number.
- Step 6** Download the software to the temporary directory /var/tmp/CSCOVsp23-install.
- Step 7** Extract the software image using the following **tar** command:
- ```
#tar xvf <filename>.tar
```
- Step 8** Run the setup program by entering the following command:
- ```
#./setup
```



Note

As an alternative to Step 8, you can avoid the GUI and install the VSPT in TTY mode by entering the command **./setup -nodisplay** and following the onscreen prompts. An X-server must be running, and the DISPLAY environment variable must be properly configured. Use one of the following commands to set the x-display variable. Your choice of a command depends on which shell you are using.

```
In “csh” or “tcsh”: setenv DISPLAY <hostname>:0
In “sh” or “ksh”: DISPLAY=<hostname>:0;export $DISPLAY
```

- Step 9** Follow the onscreen prompts.



Note

If a previous version of the Cisco VSPT is installed on the workstation, you may be asked if you want to uninstall it, depending on the version to which you are upgrading. If you answer no, the installation is aborted.

Step 10 Remove the /var/tmp/CSCOVsp23-install directory when the installation is complete by entering the following command:

```
#rm -rf /var/tmp/CSCOVsp23-install
```

Step 11 Change to the installation directory, /opt/CSCOVsp23, by entering the following command:

```
#cd /opt/CSCOVsp23
```

Step 12 Run the CSCOVsp23 program by entering the following command:

```
#./vspt
```

Installation of the VSPT software is now complete. [Table 1-2](#) defines the default VSPT directories and files. If you have questions or need assistance, see the [Obtaining Technical Assistance](#) section.

Table 1-2 VSPT Installation Directories and Files

/opt/CSCOVsp23	
vspt	VSPT application script
classes/	Class and property files
/docs	
/help	
images/	
jre/	Java Runtime Environment
/netscape	Netscape web browser files
uninstall/	Uninstall script directory
/utils	
version	VSPT version
/var/opt/CSCOVsp23 (home directory)	
data/	Configuration files
logs/	Log files
/etc	



Note

The directories and files listed in [Table 1-2](#) are for the most recent version of VSPT Release 2. Your directory structure may be different if you are using an older version or VSPT Release 2.

VSPT Basics

This section describes the requirements for entering provisioning data using the VSPT.

VSPT Field Definitions

Table 1-3 lists VSPT field names, which correspond to system components in the Cisco MGC, and their definitions. For more information about system components, refer to the *Cisco Media Gateway Controller Software Release 9 Provisioning Guide*.

Table 1-3 Field Name Definitions

Field Name	Definition
MGC Host	An origination point code (OPC) is the address of the Cisco MGC you are provisioning.
Interfaces (Cards)	Ethernet hardware cards and virtual interfaces (connections) for the Ethernet cards in the Cisco MGC host.
Adjacent Point Code	An adjacent point code (APC) is the address of an STP ¹ that sends and receives signaling messages to and from the Cisco MGC.
LinkSet	A LinkSet is a set of links from the MGC to an endpoint, such as an adjacent STP.
C7 IP Link	A link to the SS7 network (for example, an SSP ² or STP) from the Cisco MGC through a Cisco SLT.
Mated Pair (SS7 Subsystem)	A logical connection between a pair of mated STPs that allows the Cisco MGC to route through either STP to an endpoint.
Point Code	A destination point codes (DPC) is the address of an endpoint, such as a PSTN ³ switch that carries the bearer traffic.
SS7 Path(SS7 Signaling Service)	An SS7 path is a connection between the Cisco MGC and a specified point code.
SS7 Route	An SS7 route is a route for each signaling path from the Cisco MGC to the PSTN switch through the linksets you have created to the STPs.
External Node	An external node is any object in the network that is connected to the Cisco MGC, for example, media gateways (Cisco MGWs) and associated BSCs ⁴ .
MGCP ⁵ Signaling Service	An MGCP signaling service is a signaling service between the Cisco MGC and a media gateway.
IPFAS Signaling Service	An IPFAS signaling service is a signaling service (over IP) between the Cisco MGC and a media gateway.
IP Link for MGCP and IPFAS	An IP Link for MGCP and IPFAS is a link for the MGCP and IPFAS signaling services.

1. STP = signal transfer point.
2. SSP = service switching point.
3. PSTN = Public Switched Telephone Network.
4. BSC = Broadband Service Card.

5. MGCP = Media Gateway Control Protocol.

Figure 1-1 shows the relationship of VSPT field names and the corresponding system components.

Figure 1-1 Component Relationships

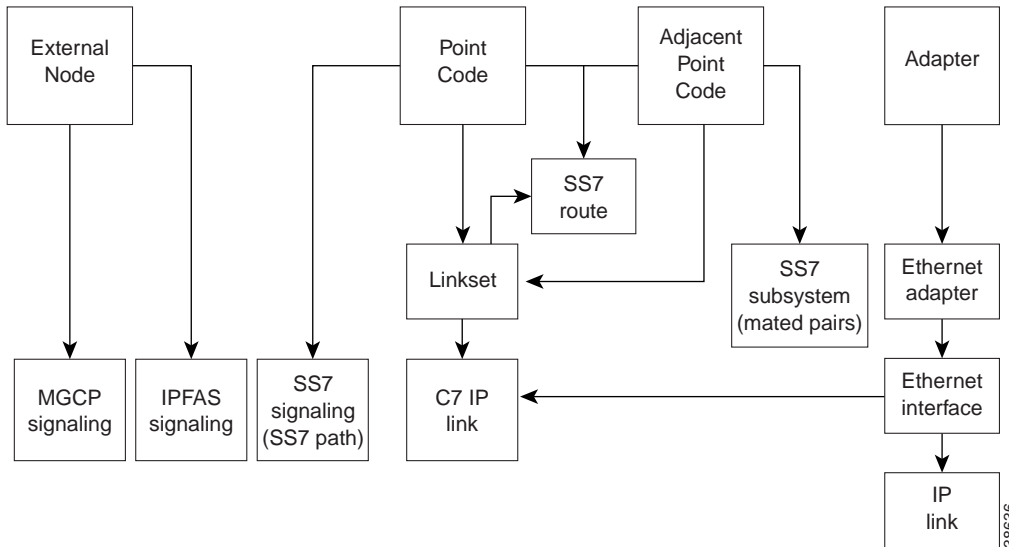

VSPT Data Entry Requirements

When you are entering data into the VSPT windows, follow standard MML conventions for names and descriptions. Each MML name must have the following characteristics:

- A maximum of 20 alphanumeric characters, including dashes
- No space, underscore, or special characters
- Must start with an alphabetic character

For example: `name="dpc1"`

MML descriptions can be as many as 128 characters and can include spaces and symbols. You should use a description that helps to identify the component or link that you are provisioning. For example, for an SS7 route, which indicates the signaling path from the Cisco MGC to a switch through a linkset, you could create a description “SS7 Route to PSTN Switch A through Linkset 1.” For more information about MML, refer to the *Cisco Media Gateway Controller Software Release 9 MML Command Reference Guide*.

The VSPT GUI enables you to step through the provisioning process in a logical sequence. The sequence of steps is described in the *Cisco Media Gateway Controller Software Release 9 Provisioning Guide*.

Starting the VSPT



Note

See the Cisco *Media Gateway Controller Software Release 9 Installation and Configuration Guide* for information on setting up user privileges and access rights.

Perform the following steps to start the VSPT:

- Step 1** Log in to the VSPT server or access it from a machine with X-window capability.
- Step 2** In a terminal window, change to the default directory:
`>cd /opt/CSCOvsp23`
 Navigate to the appropriate directory if you installed the VSPT in a different location.
- Step 3** **Enter the following command to start the VSPT:**
`>./vspt`
 The system opens X-windows, and the login screen shown in [Figure 1-2](#) appears.

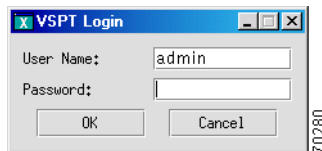
Figure 1-2 Login Screen



- Step 4** Enter your user name and password, and click **OK**.
 The default user name is admin, and the password is also admin. The Welcome screen is displayed briefly during the login process, and the main window appears (see [Figure 1-3](#)).

Figure 1-3 Main VSPT Window

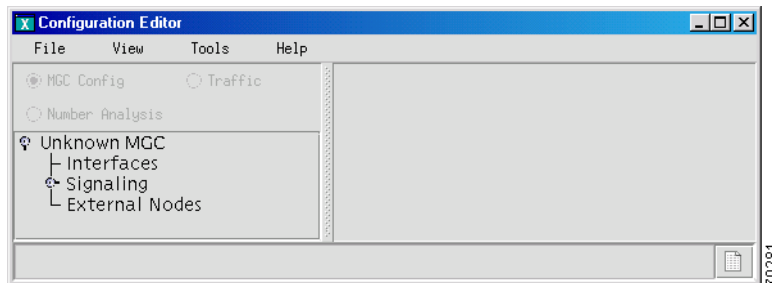

Using the VSPT

This section describes the VSPT menus and buttons and provides directions for using the tool functions.

Menu Bar

The VSPT provides a menu bar that contains the following selections:

- File
- View
- Tools
- Help

Table 1-4 lists the File menu choices.

Table 1-4 File Menu Command Choices

Command	Description
New	Begin a new configuration session
Open	Open an existing configuration
Import	Import an existing configuration from an MGC, or import trunk group, trunk, routing, or dial plan files into the VSPT
Export	Export configuration files from the VSPT to a specified directory
Save	Save the current configuration: <ul style="list-style-type: none"> • As Working: Use to save a new configuration, either a configuration imported from the Cisco PGW or a configuration created in VSPT, and to save modifications to an existing configuration, overwriting the last version. The configuration is saved in the <code>/var/opt/CSCOVsp23/data/mgc/mistral</code> directory. • As Snapshot: Use to save modifications to an existing configuration under a new name in the ARCHIVE directory. The snapshot configuration is saved in <code>/var/opt/CSCOVsp23/data/mgc/mistral/<configname>/ARCHIVE</code> • As New Config: Use to save a modified configuration under a new name, leaving the original intact.
Exit	Stop any open provisioning sessions and close the VSPT

Table 1-5 lists the View menu command choices.

Table 1-5 View Menu Command Choices

Command	Description
MML	Show generated MML for the current configuration
MGW Commands	Show generated Cisco MGX 8850 commands for the current configuration
Trunk Group File	Show generated trunk group file for the current configuration
Trunk File	Show generated trunk file for the current configuration

Table 1-6 lists the Tools menu command choices.

Table 1-6 Tools Menu Command Choices

Command	Description
Integrity Check	Check your configuration for inconsistencies and missing information
Deploy	Move the configuration to one or more target hosts and Cisco media gateways (MGWs)
Telnet	Open a telnet session
MGC Viewer	View, activate, remove, and synchronize configurations on the MGC.
MGX-8850 Wizard	View and configure MGX 8850 hosts. Refer to the Cisco Media Gateway Controller Software Release 9 Provisioning Guide for information about the MGX-8850 Wizard.
BAMS Config	View and configure a Billing and Measurements Server (BAMS). Refer to the Billing and Measurements Server User's Guide for your release of BAMS for information about BAMS configuration.
State Operation	View and configure the state of MGC components.
Screening Editor	View and configure screening number provisioning. Refer to the Cisco MGC Software Release 9 Dial Plan Guide for information about using the VSPT Screening Editor.
Audit	Audit bearer trunk information between the Cisco MGC and the BAMS.
Backup and Restore	Create, modify, or delete scheduled backups or restores on the MGC Host, CAT2900XL, CAT5500, CAT6509, SLT2600, BAMS P2, BAMS P3, and HSI adjunct server components.
Make a Seed File	Use an existing configuration to create a text file that can be used by the Cisco MGC Node Manager (CMNM) to deploy or discover devices in the network.

Table 1-7 lists the Help menu command choices.

Table 1-7 Help Menu Command Choices

Command	Description
About VSPT	View information about the current version of VSPT, including the software release number
VSPT User's Menu	View online help information

Buttons

The VSPT provides buttons and explorer trees that you can use to move through the system. Click these buttons to add or change network components. The VSPT contains the following buttons:

- MGC Config—Add components and provision component properties
- Traffic—Create customer-specific files, including trunk groups, trunks, and routing
- Number Analysis—Provision dial plans

The left pane of the main VSPT screen displays selectable components. The right pane of the screen displays data entry fields. Click a component to select it. To see all of the subcomponents for the component you select, click the icon next to the component name to expand the component list.

**Note**

For instructions for using the VSPT to provision components, component properties, trunk groups, trunks, and routing, refer to the *Cisco Media Gateway Controller Software Release 9 Provisioning Guide*. For instructions for using the VSPT to provision a dial plan, refer to the *Cisco Media Gateway Controller Software Release 9 Dial Plan Guide*.

The Help menu selections display an html version of this guide and information about the current software release number.

Defining Users and Permissions

After you install the VSPT, you define users and their respective permissions using the following procedure:

Step 1 Log in to the server as root and start VSPT 2.

Step 2 Click **Tools > User Admin** on the menu bar.

The screen in [Figure 1-4](#) appears.

Figure 1-4 VSPT User Administration

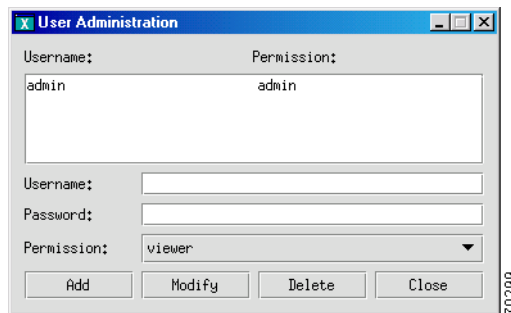

Step 3 Add, modify, or delete user definitions as follows:

- To add a user, enter a user name and password, click **Permission**, select the permission level, and click **Add**.
- To modify a user, select the user name, change the password or permission level, and click **Modify**.
- To delete a user, select the user name, and click **Delete**.

Exiting the VSPT

You can exit the VSPT at any time by performing one of these actions:

- Click **File > Exit**. Click **OK** at the resulting prompt.

- Click the close box in the upper right of the VSPT screen. Click **OK** at the prompt.



Provisioning with VSPT Wizards

Wizards are utilities included in the Cisco Voice Services Provisioning Tool (VSPT) that can help you rapidly create a new MGC configuration deployment by providing a graphical user interface (GUI) for provisioning specific solutions. A wizard leads you through the steps of provisioning the Cisco MGC and the external components of the solution you choose.



Note

A *solution* is a logical combination of Cisco hardware and software configured to perform a specific network task.

This chapter provides an example of using a wizard to configure a solution. It includes the following sections:

- [Starting a New Provisioning Session, page 2-1](#)
- [Overview of the VSPT Wizards, page 2-2](#)
- [Using the Tandem Transit with STP Solution Wizard, page 2-3](#)

Starting a New Provisioning Session

When you start a new provisioning session, you can choose to base the configuration on an existing configuration, by using the Import from MGC option, or you can use a configuration wizard, or you can perform the configuration manually.

Use the following procedure to start a new VSPT provisioning session:

-
- Step 1** Start and log in to the VSPT.
 - Step 2** Select **File > New** on the menu bar.
 - Step 3** Enter a name for the new configuration you will create, and click **OK**. The screen shown in [Figure 2-1](#) appears.

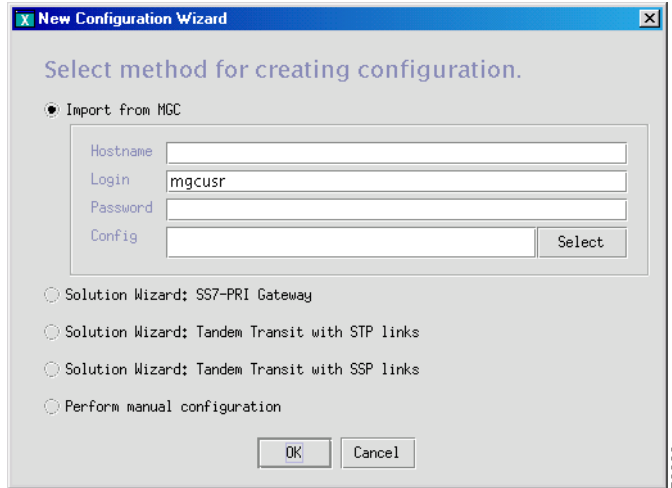
Figure 2-1 Select Method for Creating Configuration

- Step 4** If you want to import an existing configuration, click the **Import from MGC** radio button, and click **Select**; otherwise, click **Perform Manual Configuration**, or choose the solution wizard to use.



Note This imports the Cisco MGC configuration only; it does not import gateway configurations. To import configurations for gateways, after importing the MGC configuration, select each gateway and import its configuration.

If you import an existing configuration, the screen shown in [Figure 2-2](#) appears.

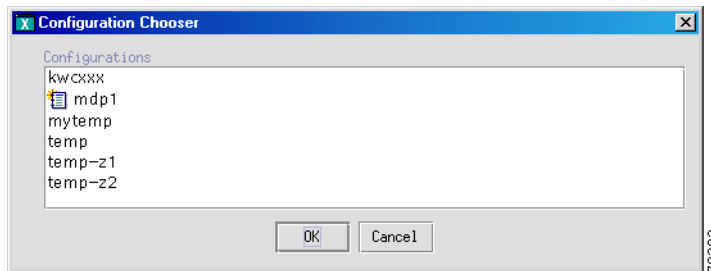
Figure 2-2 Select Configuration

- Step 5** Select the configuration to import, and click **OK**. The configuration will be imported from your Cisco MGC.

Overview of the VSPT Wizards

The VSPT includes the following solution provisioning wizards:

- SS7-PRI Gateway—Offloads modem dial traffic from competitive local exchange carrier (CLEC) switches and either forwards the calls, using SS7, to the destination CLEC switches or translates the primary rate access calls to integrated services digital network (ISDN PRI) to terminate them on the network access server (NAS) gateways.
- Tandem Transit with STP Links—Offloads modem dial traffic from CLEC switches and forwards the calls to the IP network through a signal transfer point (STP).
- Tandem Transit with SSP Links—Offloads modem dial traffic from CLEC switches and forwards the calls to the Internet Protocol (IP) network with no intermediate connection to STPs.

Each wizard automatically guides you through the steps involved in creating a provisioning configuration for a specific solution. A VSPT wizard:

- Lets you create configuration files across multiple devices, for example, MGCs and Cisco MGX 8850s
- Helps you avoid common errors when you are provisioning devices independently (for example, ensuring that you correctly match D-channels for PRI)
- Lets you avoid having to repeatedly enter duplicate data
- Creates the MML files and the Cisco MGX 8850 command files you use to provision the Cisco MGC and MGX 8850

The example in this chapter uses a wizard to provision a tandem transit with STP links solution, but the process is similar for all VSPT wizards. Specific components and steps vary, depending on the solution wizard you are using; for a complete description of solution components, refer to the documentation for that solution.

When you finish the provisioning session, the VSPT wizard saves your configuration as the “active” configuration, and that configuration cannot be modified. To make changes, you must save the configuration with another name and deploy the new provisioning session to make it active.

The number of configurations you can store might be limited by available disk space. Consider deleting old or unwanted configurations, or save them to another machine, if you do not have sufficient disk space.

**Note**

The provisioning procedures described in this chapter follow the sequence for provisioning a “typical” Cisco MGC described in the *Cisco Media Gateway Controller Software Release 9 Provisioning Guide*.

Using the Tandem Transit with STP Solution Wizard

The VSPT utility, Solution Wizard: Tandem Transit with STP Links, guides you step-by-step through the following procedures:

- [Configuring the Cisco MGC, page 2-4](#)
- [Configuring SS7 Signaling Services, page 2-6](#)
- [Configuring Media Gateway Control Links, page 2-8](#)

When you finish using the VSPT wizard, you must still configure the trunk groups, trunks, and routes. For more information, see the *Cisco Media Gateway Controller Software Release 9 Provisioning Guide*.

**Tip**

Before you begin provisioning, compile information about the solution components, including their names, IP addresses, and properties. Worksheets designed for collecting this information are provided in the *Cisco Media Gateway Controller Software Release 9 Provisioning Guide*. Complete them before you begin provisioning, and refer to them during provisioning.

Configuring the Cisco MGC

Use the following procedure to provision a Cisco MGC using the Tandem Transit with STP solution wizard:

- Step 1** Start a new provisioning session, and click **File > New** on the menu bar.
- Step 2** Click the **Solution Wizard: Tandem Transit with STP** radio button, and click **OK**. A screen similar to the one in [Figure 2-3](#) appears.

Figure 2-3 Specifying Cisco MGC Properties

- Step 3** Enter the MGC IP address, for example, 172.31.157.1, in the MGC Hostname field.
- Step 4** Enter a login ID and a password.
- Step 5** Click **Next**. A screen similar to the one in [Figure 2-4](#) appears.

Figure 2-4 Specifying MGC IP Addresses

- Step 6** Enter the network addresses of the MGC (IP_Addr1 and IP_Addr2) in dotted decimal notation, for example, 172.18.145.38.
- Step 7** Click **Next**.
- Step 8** If the Cisco MGC has a failover Cisco MGC, click the radio button next to **Has a failover MGC**, and enter the network addresses of the failover Cisco MGC (**IP_Addr1** and **IP_Addr2**). Use dotted decimal notation. If there is no failover Cisco MGC, click the radio button next to **Does not have a failover MGC**. The IP_Addr 1 and IP_Addr 2 fields are not valid and are grayed out when there is no failover MGC.
- Step 9** Click **Next**. A screen similar to the one in [Figure 2-5](#) appears, and SS7 signaling service provisioning begins.

Figure 2-5 Specifying a Point Code

Configuring SS7 Signaling Services

Use the following procedure to configure SS7 signaling services:

-
- Step 1** Enter a name, for example, OPC, in the Name field on the screen shown in [Figure 2-5](#).
- Step 2** Enter a description of the OPC, for example, Originating Point Code.
- Step 3** Enter the OPC network address (NetAddr) in dotted notation, for example, 1.1.2.
- Step 4** From the NetIndicator drop-down menu, choose a network indicator menu. There are four options.
- International—Used if the node is an international gateway.
 - Spare—In countries where multiple carriers share point codes, networks are differentiated by this indicator.
 - National—Used if the node routes calls through the national network (default value).
 - Reserved—For national use. Do not use.
- Step 5** From the OPC type indicator, choose either TRUEOPC or CAPOCP.
- Step 6** Leave the True OPC indicator at <UNSET>.
- Step 7** Click **Next**.
- Step 8** Enter the number of adjacent point codes (APCs) to create, corresponding to the number of Cisco MGX 8850 switches to be provisioned. Click **Next**. screen similar to the one in [Figure 2-6](#) appears.

Figure 2-6 Specifying Properties for Each APC

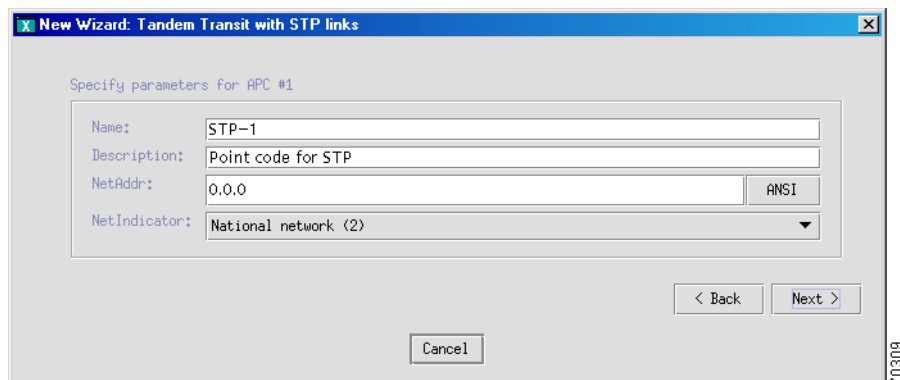

- Step 9** Enter the APC name.
- Step 10** Enter a description of the APC.
- Step 11** Enter the network address (NetAddr) in dotted notation; for example, 2.2.1.
- Step 12** From the NetIndicator drop-down menu, choose the network indicator:
- International—Used if the node is an international gateway.
 - Spare—In countries where multiple carriers share point codes, networks are differentiated by this indicator.
 - National—Used if the node routes calls through the national network (default value).
 - Reserved—For national use. Do not use.

- Step 13** Click **Next**. A series of screen similar to the one in [Figure 2-6](#) appears sequentially for each APC you specified in [Step 8](#).
- Step 14** Repeat [Step 9](#) through [Step 13](#) for each APC screen. After you have configured properties for each APC you specified in [Step 8](#), a screen similar to the one shown in [Figure 2-7](#) appears.

Figure 2-7 Specifying Properties for Mating APCs

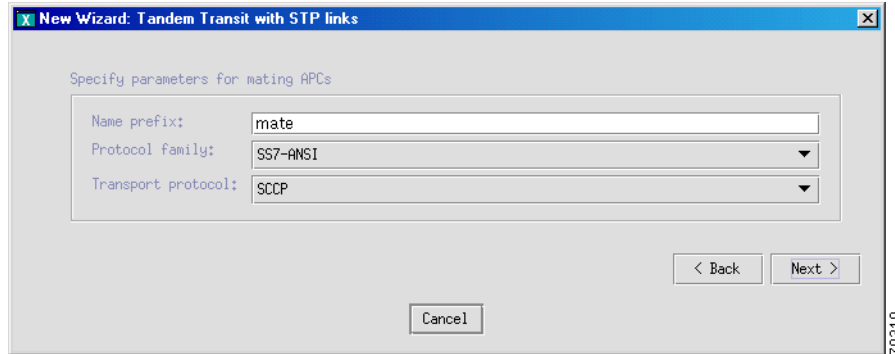

- Step 15** Enter the name prefix for the subsystem (default is mate).
- Step 16** Choose the protocol family.
- Step 17** Choose the transport protocol.
- Step 18** Click **Next**. A screen similar to the one in [Figure 2-8](#) appears.

Figure 2-8 Specifying a Protocol for Linksets

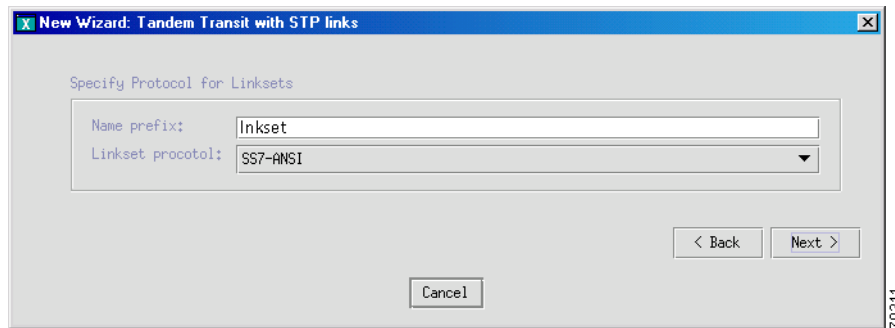

- Step 19** Enter the name prefix for the linkset (default is lnkset).
- Step 20** From the Linkset protocol drop-down menu, choose the linkset protocol for the linkset you are configuring.
- Step 21** Click **Next**. A screen similar to the one in [Figure 2-9](#) appears.

Figure 2-9 Specifying Values for C7 IP Inks

- Step 22** Enter the name prefix (the default is c7ip).
- Step 23** Enter the network addresses (IP addr for SLT 1 and IP addr for SLT 2) in dotted notation; for example, **172.16.145.38** and **172.16.145.40**.
- Step 24** Enter the local port on the SLT.
- Step 25** Click **Next**. A screen similar to the one in [Figure 2-10](#) appears, and you can begin configuring media gateway control links.

Figure 2-10 Specifying the Number of Destination Point Codes

Configuring Media Gateway Control Links

Use the following procedure to configure MGC links for this solution.

- Step 1** Enter the number of DPCs to create, in the window shown in [Figure 2-10](#).
- Step 2** Click **Next**. A screen similar to the one in [Figure 2-11](#) appears.

Figure 2-11 Specifying Properties for Each DPC

Specify parameters for DPC #1

DPC Name: DPC-1

Netaddr: 3.3.3 ANSI

SS7Path Name: SP-DPC-1

MDO: ANSISS7_STANDARD

Customer group ID: 0000

< Back Next >

Cancel

70302

- Step 3** Enter the DPC name.
- Step 4** Enter the network address of the destination network element in dotted notation; for example, 172.16.145.38.
- Step 5** Enter the SS7 path name.
- Step 6** From the MDO drop-down menu, choose the protocol for this signaling service, for example, ANSISS7_STANDARD.
- Step 7** Enter the Customer group ID.
- Step 8** Click **Next**.
- Step 9** Enter the SS7 route name prefix, and click **Next**.
- Step 10** A screen similar to the one in [Figure 2-12](#) appears.

Figure 2-12 Importing VISMs from the MGX 8850 Chassis

Importing VISMs from MGX-8850 chassis

MGX-8850 Hostname

Login

Password

Import VISMs

Selected	Slot	State	MGC	External Node Name

< Back Finish

Cancel

70303

- Step 11** Enter the name of the MGX 8850 host in which the VISM cards are installed.

- Step 12** Enter the login ID for the MGX 8850 host.
- Step 13** Enter the password.
- Step 14** Click **Import VISM**s. A list of the imported MGX 8850 switches appears in the lower portion of the screen.
- Step 15** Click **Finish**. You can now provision trunk groups, trunks, and routes for this solution. Refer to the *Cisco Media Gateway Controller Software Release 9 Provisioning Guide*.

Provisioning Session Results

The results of the provisioning session you just completed are visible in the hierarchical tree in the left pane of the main VSPT screen, as shown in [Figure 2-13](#).

Figure 2-13 Expanded Hierarchical Tree Showing Results of Provisioning Session

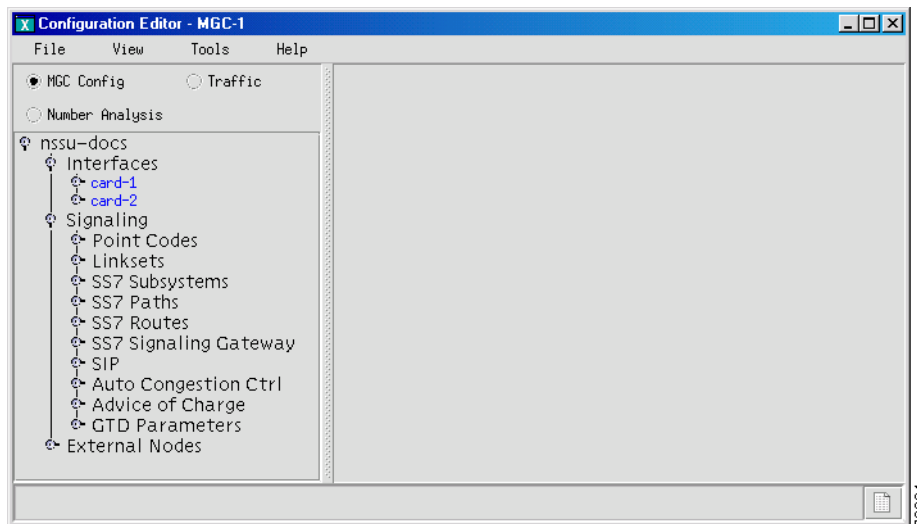

You can expand the branches to view individual components. To view the provisioning information for a particular system component, click on the component name. Information about the selected component is shown on the right-hand side of the screen (see [Figure 2-14](#) for an example).

Figure 2-14 View a Selected Component Configuration

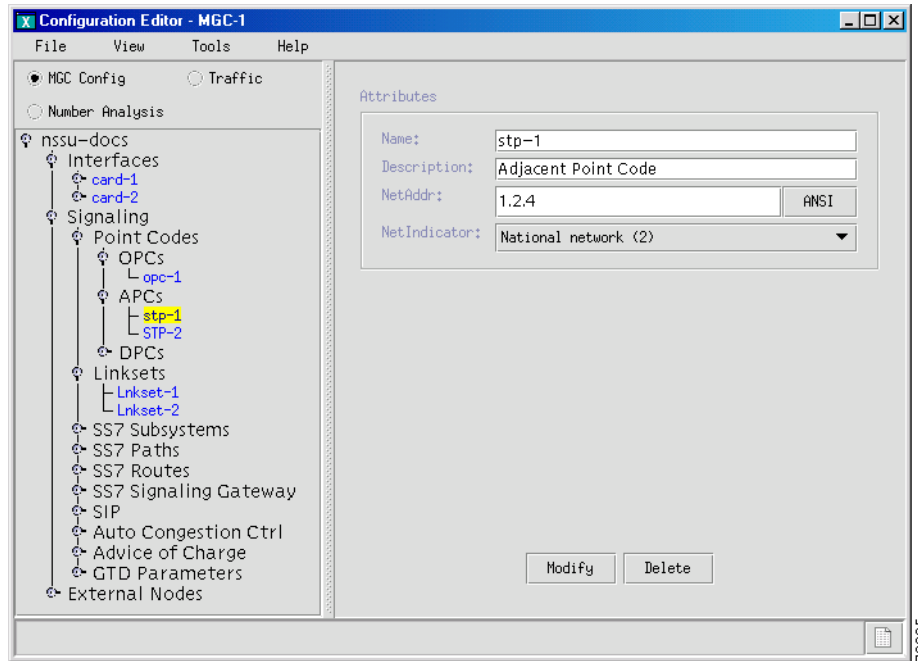

You cannot use the VSPT wizard to provision trunk groups, trunks, and routes. For more information about provisioning these components using the VSPT, see the *Cisco Media Gateway Controller Software Release 9 Provisioning Guide*.

Viewing Generated MML

To view the MML commands generated by the VSPT wizard, refer to the [“View Generated MML Commands”](#) section on page 3-4.



Voice Services Provisioning Tool Utilities

VSPT Release 2.3(1) provides many utilities, including tools to accomplish the following tasks:

- [Perform an Integrity Check, page 3-1](#)
- [View Generated MML Commands, page 3-4](#)
- [View Generated Cisco MGW Commands, page 3-4](#)
- [Deploy a Configuration, page 3-5](#)
- [Telnet, page 3-9](#)
- [MGC Viewer, page 3-10](#)
- [State Operation, page 3-12](#)
- [Perform an Audit, page 3-13](#)
- [Back Up and Restore, page 3-15](#)

Perform an Integrity Check

When provisioning is complete, you can perform an integrity check to prevent possible configuration errors. The integrity check involves:

- [Checking Integrity for MGC Signaling Configuration](#)
- [Checking Traffic Against MGC Configuration](#)
- Checking Dial Plan Results

Each integrity check is explained in more detail in the following subsections.

Checking Integrity for MGC Signaling Configuration

When you perform an integrity check for MGC signaling configuration, the VSPT does the following:

- Checks that the hostname is specified for MGC
- Checks that login/passwords are specified for MGC
- Checks that MGC ipaddr are specified
- Checks that if MGC failover is specified, the failover IPs are specified
- Checks that MGX hostname is specified

- Checks that MGX login/password is specified
- Checks the MGX IPaddr
- For EXTNODES where the configuration refers to an MGX, checks PeerAddr on IPLNK to ensure that they are addresses on the specified MGX
- For IPFAS IPLNK:
 - Ensures that SigSlot/SigPort is specified
 - Checks SigSlot/SigPort on MGX to ensure that the values are valid as specified on the MGX
 - Ensures that MGC ports and MGX ports match on the IPLNK
 - Checks that all IPLNK under a single IPFASPATH map to the same port number



Note The number of IPFAS sessions utilizing a given port is displayed because some IPLNKs might use different port IDs.

Checking Traffic Against MGC Configuration

When you perform an integrity check of traffic against the MGC configuration, the VSPT does the following:

- When D-channels are defined as FAS and NFAS PRI in the trunk group/trunk section, verifies that there are corresponding IPFASPATH signaling services with corresponding IPLNKs
- Checks if there are any defined IPFASPATH signaling services defining a D-channel but no corresponding trunk group/trunk in the traffic information with a corresponding NFAS/FAS PRI.
- Checks that signaling services defined for trunk groups exist in the configuration

For information about an integrity check of dial plan results, refer to the Cisco *Media Gateway Controller Software Release 9 Dial Plan Guide*.

Use the following procedure to perform an integrity check of your configuration:

-
- Step 1** Click **Tools > Integrity Check**. The screen shown in [Figure 3-1](#) appears.

Figure 3-1 Integrity Check

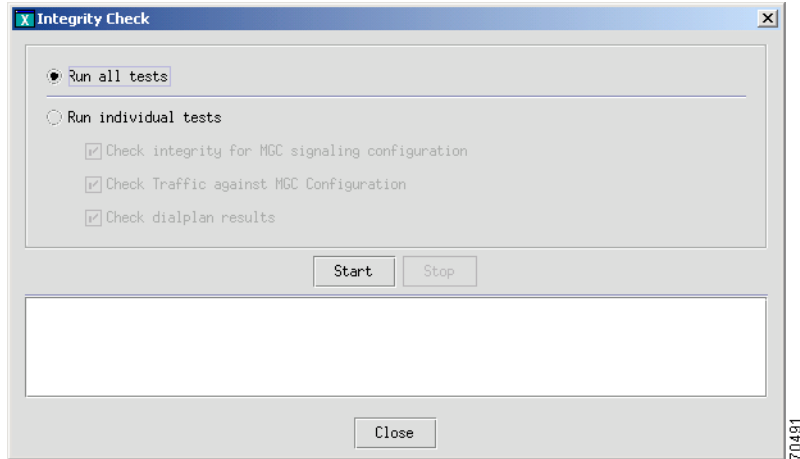

Step 2 Indicate the tests you want to run, and click **Start**.

When the tests finish, a screen similar to the one in [Figure 3-2](#) appears showing the results of the integrity checks.

Figure 3-2 Integrity Check Results

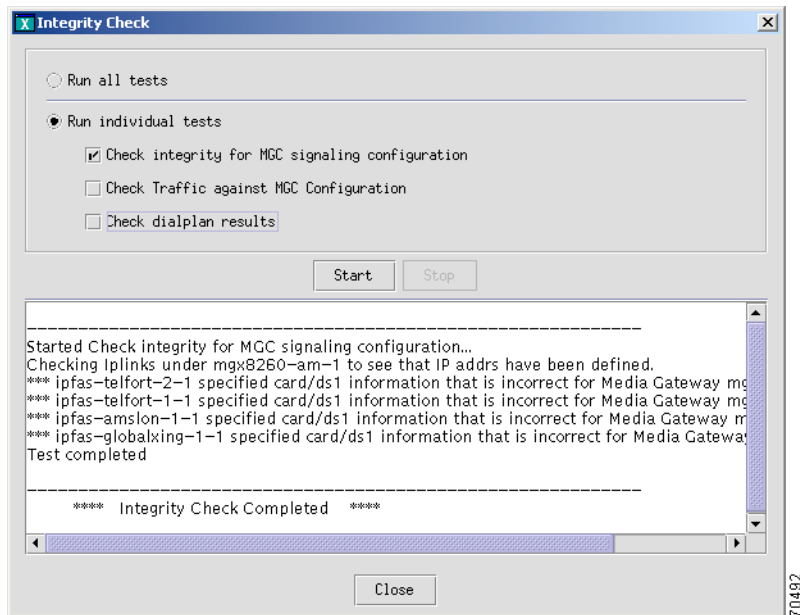

View Generated MML Commands

The VSPT automatically generates MML commands to provision your Cisco MGC and saves these commands in a file to be executed when you deploy the configuration. To view the MML commands generated from your VSPT provisioning session, click **View > MML** on the VSPT menu bar. A screen displaying generated MML, similar to the one shown in [Figure 3-3](#), appears.

Figure 3-3 First Generated MML Screen

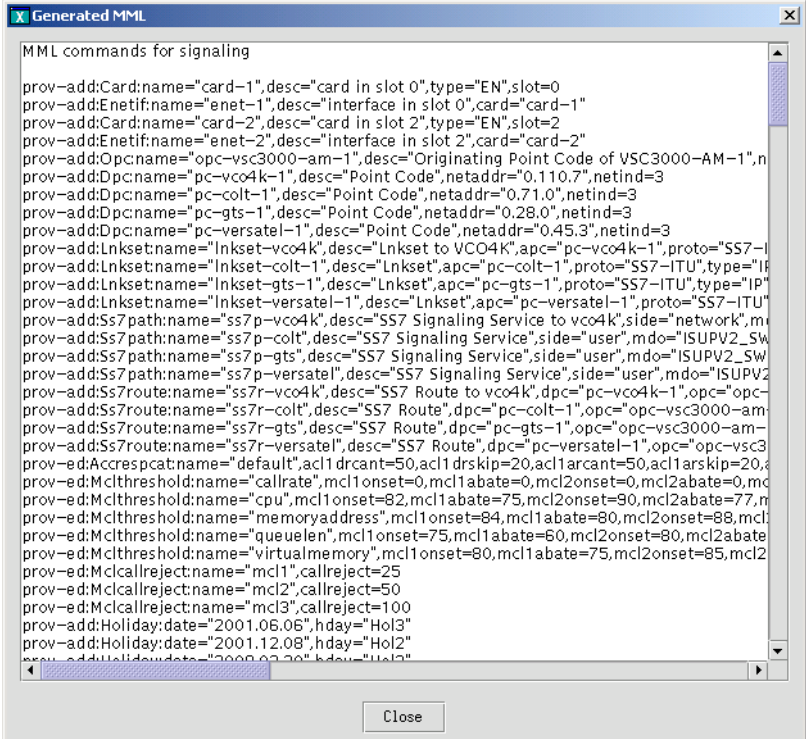

```

MML commands for signaling

prov-add:Card:name="card-1",desc="card in slot 0",type="EN",slot=0
prov-add:Enetif:name="enet-1",desc="interface in slot 0",card="card-1"
prov-add:Card:name="card-2",desc="card in slot 2",type="EN",slot=2
prov-add:Enetif:name="enet-2",desc="interface in slot 2",card="card-2"
prov-add:Dpc:name="opc-vsc3000-am-1",desc="Originating Point Code of VSC3000-AM-1",netaddr="0.110.7",netind=3
prov-add:Dpc:name="pc-vco4k-1",desc="Point Code",netaddr="0.71.0",netind=3
prov-add:Dpc:name="pc-colt-1",desc="Point Code",netaddr="0.71.0",netind=3
prov-add:Dpc:name="pc-gts-1",desc="Point Code",netaddr="0.28.0",netind=3
prov-add:Dpc:name="pc-versatel-1",desc="Point Code",netaddr="0.45.3",netind=3
prov-add:Lnkset:name="lnkset-vco4k",desc="Lnkset to VCO4K",apc="pc-vco4k-1",proto="SS7-ITU",type="IP"
prov-add:Lnkset:name="lnkset-colt-1",desc="Lnkset",apc="pc-colt-1",proto="SS7-ITU",type="IP"
prov-add:Lnkset:name="lnkset-gts-1",desc="Lnkset",apc="pc-gts-1",proto="SS7-ITU",type="IP"
prov-add:Lnkset:name="lnkset-versatel-1",desc="Lnkset",apc="pc-versatel-1",proto="SS7-ITU",type="IP"
prov-add:Ss7path:name="ss7p-vco4k",desc="SS7 Signaling Service to vco4k",side="network",mdo="ISUPV2_SW"
prov-add:Ss7path:name="ss7p-colt",desc="SS7 Signaling Service",side="user",mdo="ISUPV2_SW"
prov-add:Ss7path:name="ss7p-gts",desc="SS7 Signaling Service",side="user",mdo="ISUPV2_SW"
prov-add:Ss7path:name="ss7p-versatel",desc="SS7 Signaling Service",side="user",mdo="ISUPV2_SW"
prov-add:Ss7route:name="ss7r-vco4k",desc="SS7 Route to vco4k",dpc="pc-vco4k-1",opc="opc-vsc3000-am-1"
prov-add:Ss7route:name="ss7r-colt",desc="SS7 Route",dpc="pc-colt-1",opc="opc-vsc3000-am-1"
prov-add:Ss7route:name="ss7r-gts",desc="SS7 Route",dpc="pc-gts-1",opc="opc-vsc3000-am-1"
prov-add:Ss7route:name="ss7r-versatel",desc="SS7 Route",dpc="pc-versatel-1",opc="opc-vsc3000-am-1"
prov-ed:Accrespcat:name="default",acl1drcant=50,acl1drskip=20,acl1arcant=50,acl1arskip=20,acl1arreject=25
prov-ed:Mclthresold:name="callrate",mcl1onset=0,mcl1abate=0,mcl2onset=0,mcl2abate=0,mcl2reject=25
prov-ed:Mclthresold:name="cpu",mcl1onset=82,mcl1abate=75,mcl2onset=90,mcl2abate=77,mcl2reject=25
prov-ed:Mclthresold:name="memoryaddress",mcl1onset=84,mcl1abate=80,mcl2onset=88,mcl2abate=77,mcl2reject=25
prov-ed:Mclthresold:name="queueulen",mcl1onset=75,mcl1abate=60,mcl2onset=80,mcl2abate=77,mcl2reject=25
prov-ed:Mclthresold:name="virtualmemory",mcl1onset=80,mcl1abate=75,mcl2onset=85,mcl2abate=77,mcl2reject=25
prov-ed:Mclcallreject:name="mcl1",callreject=25
prov-ed:Mclcallreject:name="mcl2",callreject=50
prov-ed:Mclcallreject:name="mcl3",callreject=100
prov-add:Holiday:date="2001.06.06",hday="Hol3"
prov-add:Holiday:date="2001.12.08",hday="Hol2"
prov-add:Holiday:date="2000.02.20",hday="Hol2"

```

View Generated Cisco MGW Commands

To view the Cisco MGW commands generated from your provisioning session, click **View > MGW Commands** on the main VSPT menu bar. A screen with generated Cisco MGW commands, similar to that shown in [Figure 3-4](#), appears.

Figure 3-4 Example of Generated Cisco MGW Commands

```

-----[MGW CLI Commands For 10.3.4.5]-----
chidletm 20
chsyslnmd 2
y
chsysip1 10.233.20.9 0.0.0.0
chsysip2 10.233.20.73 0.0.0.0
addsonetln 9.1
chmpc 3
chndinf ## 1
chpcksrc 9 1 3 1
addmacsapprof 1 1 # 15
adddsp 1 ##### 0
chmgcpdname mgx8260-am-1
chmgcplocaladdr1 10.233.20.9 2427
chmgcplocaladdr2 10.233.20.73 2427
chmgcpaddr 172.18.126.51 2427 0.0.0.0 0
chmgpcaddr 0.0.0.0 0.0.0.0 0
chmgpcore ## 1 ## 2000
addssset 1 1 1 12 3 1
addsrp 1 1
addsess 1 1 1 10.233.20.9 7009 172.18.126.51 7009 1
addsln 1.1 1 4 ## 1
addsln 2.2 1 4 ## 1
addsln 3.3 1 4 ## 1
addsln 4.1 16 4 ## 1
addsln 5.4 1 4 ## 1
addvport 1 1 1 1 15
addvport 1 17 1 17 15
addvport 2 3 2 0 31
addvport 3 6 3 2 31 31
addvport 4 1 1 1 496 512
addvport 5 9 4 3 30 31
adddchan 1.1 1 # 1

```

70494

Deploy a Configuration

When you finish defining a configuration, you must deploy that configuration to the Cisco MGC. You can deploy to the Cisco MGC alone, to the Cisco MGC and one or more gateways, or to gateways only.



Note

A new configuration should not be deployed during times of peak load on the Cisco MGC.

A configuration created in VSPT can be deployed to a Cisco MGC as a new configuration or incrementally. Deploying incrementally allows you to more quickly deploy modifications to an existing configuration without having to redeploy the entire configuration. VSPT also allows you to visually check the incremental commands it generates before deploying those commands to the MGC.

Deploying a New Configuration

Use the following procedure to deploy a new configuration.



Note

If you want to delete a component and plan to reuse the component name, first delete the component, deploy the session, and verify that the component name has been deleted before reusing the name.

- Step 1** Click **Tools > Deploy** on the main VSPT menu bar (see [Figure 1-3 on page 1-11](#)). The screen shown in [Figure 3-5](#) appears.

Figure 3-5 Deploying a Configuration

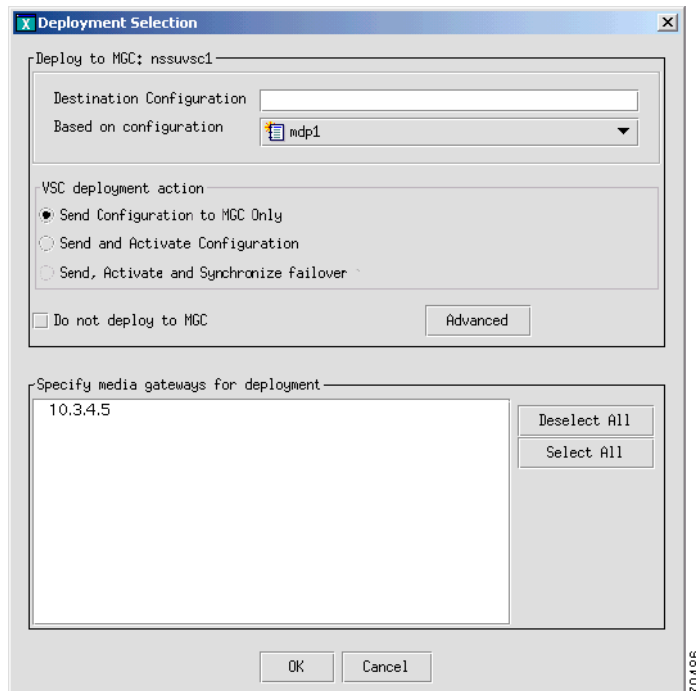

- Step 2** Indicate how you want to deploy the configuration:

- To deploy to the Cisco MGC only, do one of the following:
 - If you want to send the configuration to the MGC but not activate it, click the button next to **Send Configuration to MGC Only**.
 - If you want to send the configuration to the MGC and activate it, click the button next to **Send and Activate Configuration**.
 - If you have a continuous-service configuration with two Cisco MGC hosts, click the button next to **Send, Activate and Synchronize failover**. The configuration is saved on the active host and copied to the standby host. You must restart the standby server after reconfiguration to apply changes.
- To deploy to the Cisco MGC and one or more selected gateways, select one of the above three options and also select one or more gateways from the list in **Specify media gateways for deployment**.
- To deploy to selected gateways only (and not the Cisco MGC): Check the box next to **Do not deploy to MGC** and select one or more gateways from the list in **Specify media gateways for deployment**.



Note To select multiple gateways, you can use standard selection methods: Shift+click to select a contiguous range, Ctrl+click to select or deselect noncontiguous gateways.



Note If you select an option other than New, the Advanced button is enabled. For information about the options this button provides, see the [“Configuring an Incremental Deployment”](#) section on page 3-8.

Step 3 Enter the configuration name on the destination MGC.

Step 4 Select a configuration in the **Based on configuration** drop-down list. This list displays all existing configurations on the selected MGC and the [LAST IMPORT] and [NEW] options.

- Last Import—The VSPT compares your provisioning session to the last imported configuration and deploys only changes you have made.



Note The LAST IMPORT option allows multiple users to modify an existing configuration. However, they must each be modifying a different area of the configuration for this option to work properly.

- New—Your entire provisioning session is deployed as a new configuration.
- Existing Configurations—VSPT imports the selected configuration from the Cisco MGC, compares the differences between that configuration and your current provisioning session, and deploys changes you have made.



Note Since you are deploying a new configuration, make sure to choose the New option in the Based on configuration drop-down list.

Step 5 Select the gateways you want to deploy, if applicable.

Step 6 Click **OK**. The screen shown in [Figure 3-6](#) appears and displays the status as the current provisioning session is deployed.

Figure 3-6 Deployment Progress

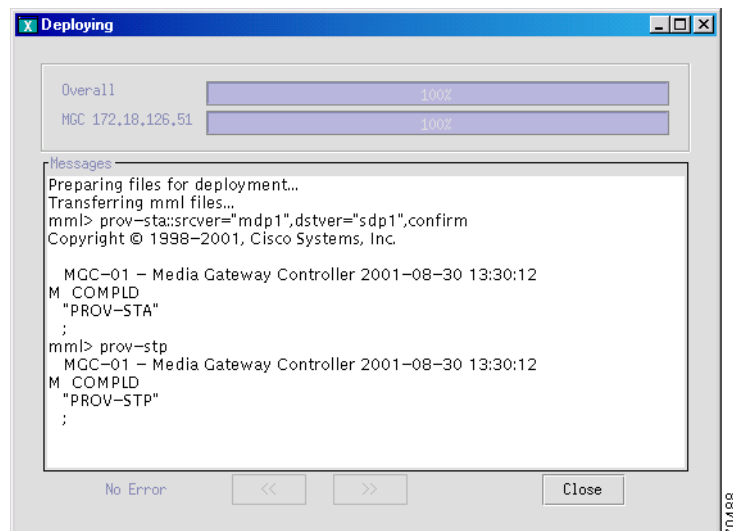

**Note**

In a continuous-service configuration, the XECfgParm.dat file on each machine must be configured. If you experience problems, verify the integrity of the XECfgParm.dat files on both machines. Refer to Chapter 2, “Installing Cisco Media Gateway Controller Software,” in the *Cisco Media Gateway Controller Software Release 9 Installation and Configuration Guide*.

Configuring an Incremental Deployment

An incremental deployment allows you to modify an existing configuration and deploy only the modified areas to the Cisco MGC. Modifications can be made more quickly, and errors affecting unmodified areas are minimized. In addition, provisioning modifications made by other users in separate areas are not affected.

**Note**

The Cisco MGC does not support some incremental deployment processes. If you have a problem with an incremental deployment, examine the MML commands to ensure that you have properly configured the desired components. Modify the component presenting the problem, or cancel the deployment and redeploy the component as a new configuration.

Use the following procedure to configure an incremental deployment:

- Step 1** Follow Step 1 through Step 4 in the “[Deploying a New Configuration](#)” section on page 3-5
- Step 2** Click **Advanced** in the window shown in [Figure 3-5](#). The screen shown in [Figure 3-7](#) appears.

Figure 3-7 Incremental Deployment Component Selector

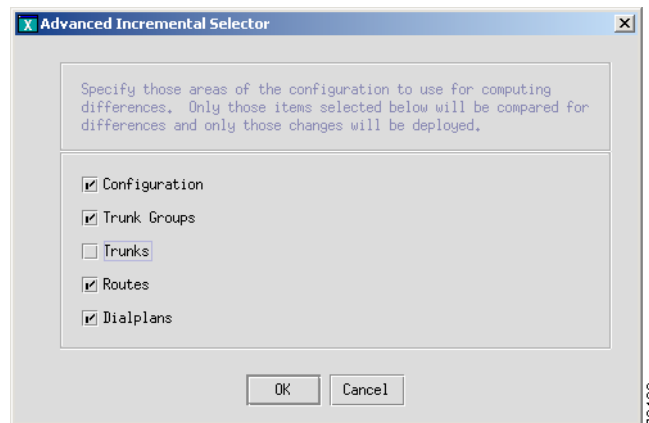

If you have only made configuration changes to one or more of the areas listed, you can direct the VSPT to compare only those areas with the current configuration, and your modifications can be deployed more quickly.

**Note**

If you select areas in this window, make sure to include all areas that you have modified.

- Step 3** Select one or more component types to deploy, and click **OK**.

- Step 4** Go to Step 6 in the “Deploying a New Configuration” section on page 3-5, and complete the procedure described there. When you click **OK**, a screen similar to the one displayed in Figure 3-8 appears.

Figure 3-8 Confirm MML Commands

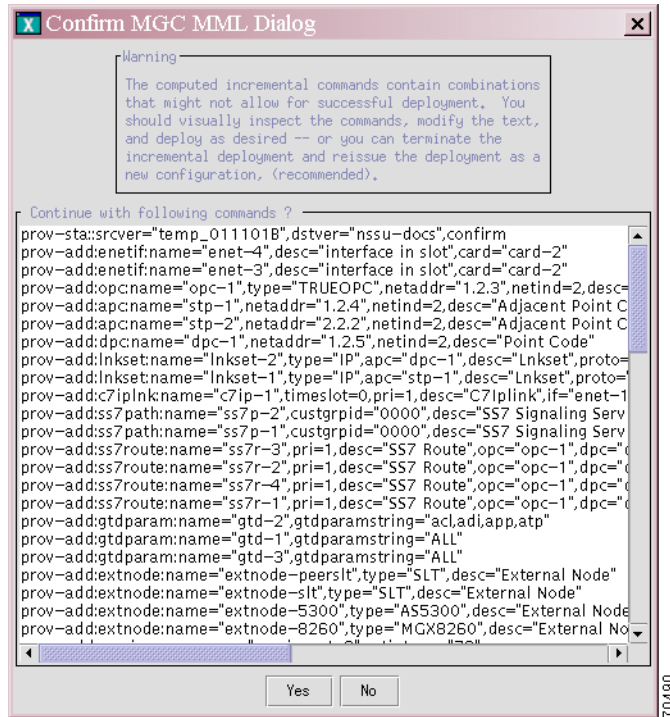

- Step 5** Inspect the MML commands, modify them if desired, and click **Yes** to continue with the incremental deployment. Click **No** to reissue the deployment as a new configuration.

Telnet

Telnet is an application based on the Telnet protocol that allows you to connect to remote computers. VSPT Release 2 provides a utility to open a telnet session directly to a network device. Once you have established your telnet connection, you then log in to that device and execute commands remotely on the device through your telnet interface.

Use the following procedure to open a telnet session with a network device:

- Step 1** Click **Tools > Telnet** on the main VSPT menu. The screen shown in Figure 3-9 appears.

Figure 3-9 Select Remote Network Device

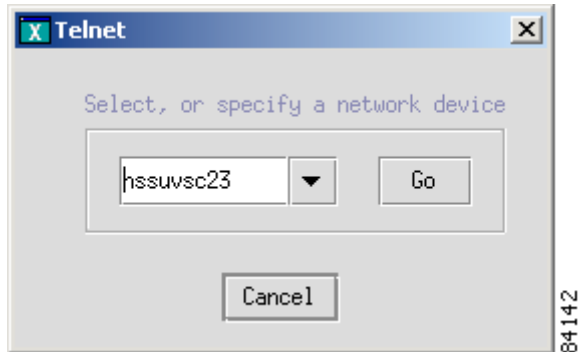

- Step 2** Select a device from the list, or enter the name or IP address of a device on your network, and click **Go**. A screen similar to the one shown in [Figure 3-10](#) appears.

Figure 3-10 Log In to Remote Device

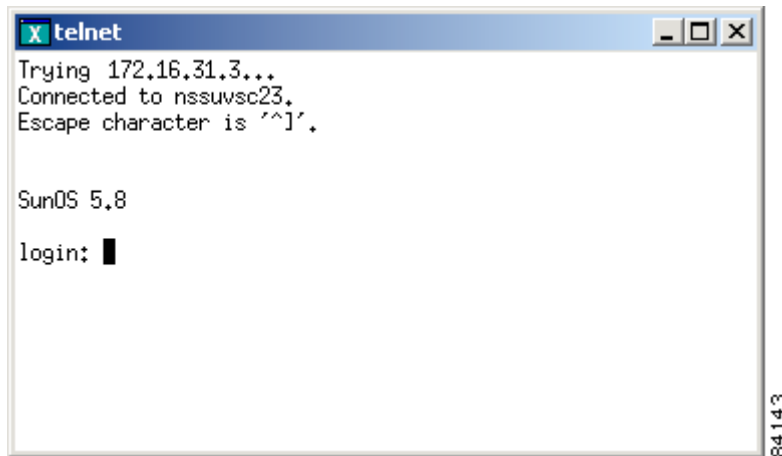

MGC Viewer

The MGC Viewer allows you to view, activate, remove, and synchronize configurations on the MGC.

Use the following procedure to view configurations on a Cisco MGC:

- Step 1** Click **Tools > MGC viewer** on the main VSPT menu. On the MGC Configuration screen that appears, click **File > Open MGC**. A screen similar to the one in [Figure 3-11](#) appears.

Figure 3-11 Select MGC

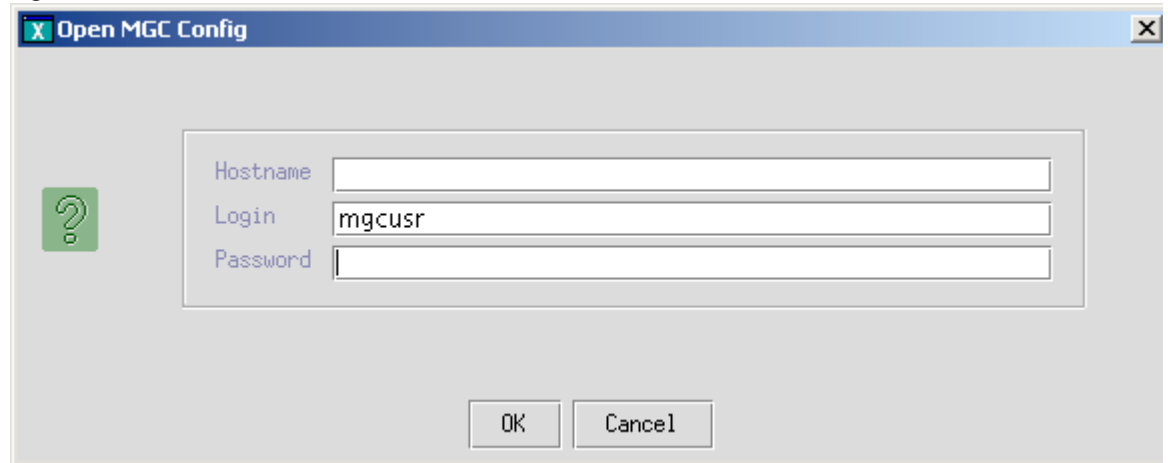

- Step 2** Enter the host name of the MGC in the **Hostname** box, enter the MGC login and password, and click **OK**. A screen similar to the one in appears and lists all configurations on the specified MGC.

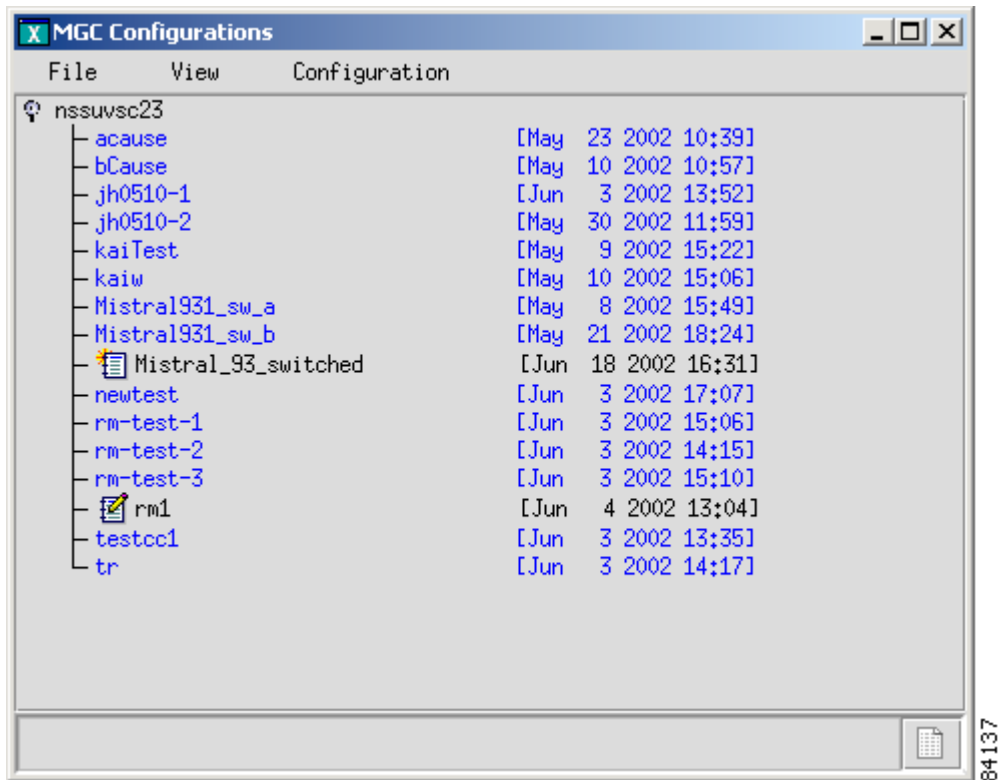

- Step 3** Click **Configuration** on the MGC Viewer menu bar, and select one of the following actions:

- Activate—
- Synchronize—
- Delete—

State Operation

The State Operation utility provides the ability to query the active configuration on the Cisco MGC for the state of managed objects. After a query, you can modify the state of an object and apply the update to the MGC.

Use the following procedure to query the state of managed objects on the Cisco MGC:

- Step 1** Click **Tools > State Operation** on the main VSPT menu. A screen similar to the one in appears.

Figure 3-12 State Operation Dialog

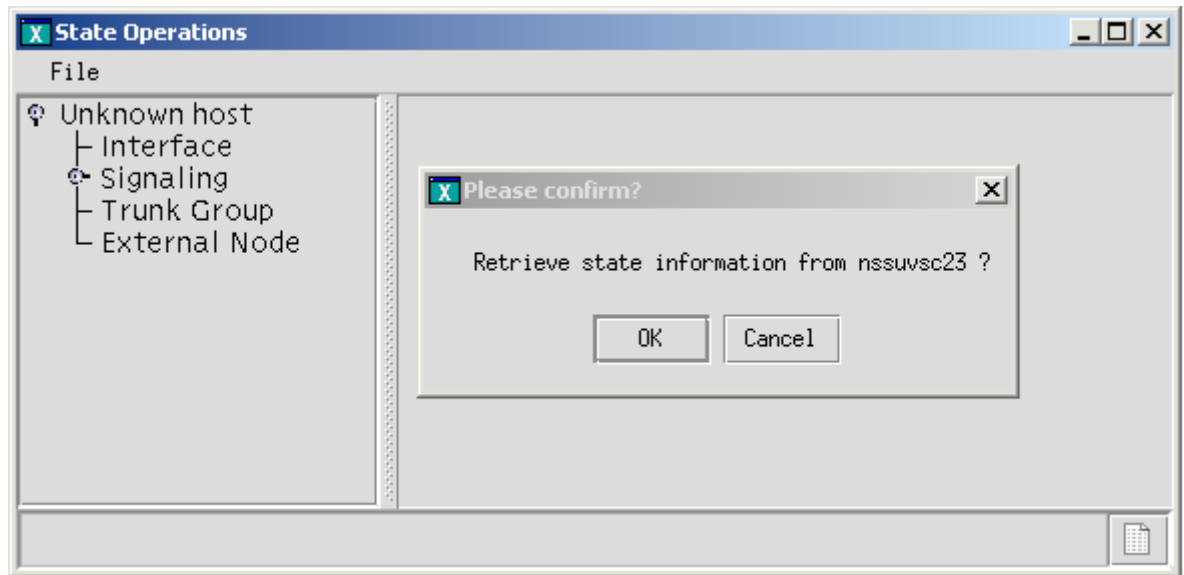

- Step 2** Click OK. The VSPT queries the MGC and a screen similar to the one in appears.

Figure 3-13 MGC Managed Objects

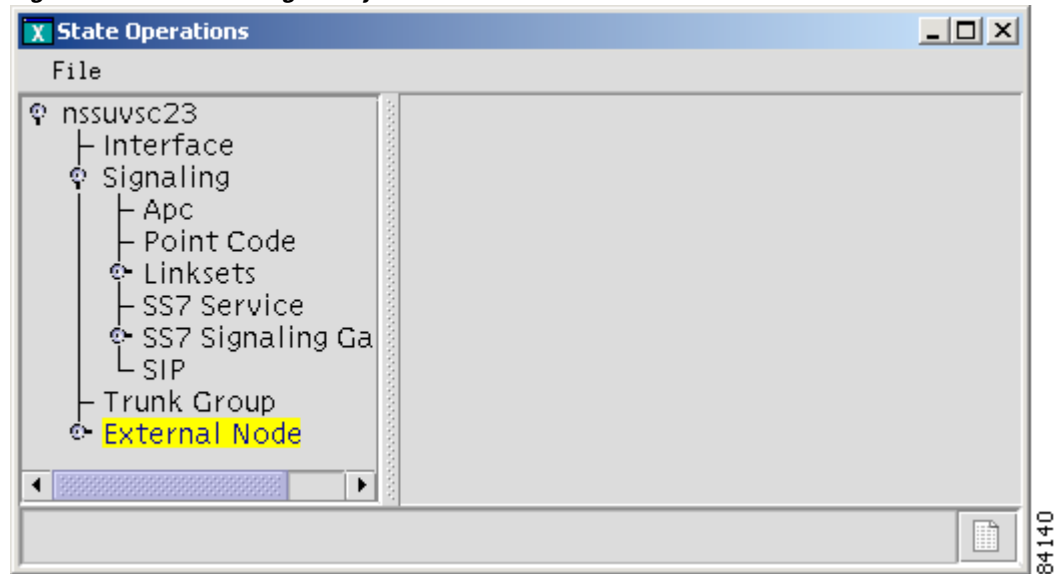

- Step 3** Expand the hierarcal tree in the left pane of the State Operations window to locate and highlight the object for which you want to know the state. In this example, we will display the state of linkset2. A window similar to the one in will appear and the right pane will display information about the state of the object you selected.

Figure 3-14

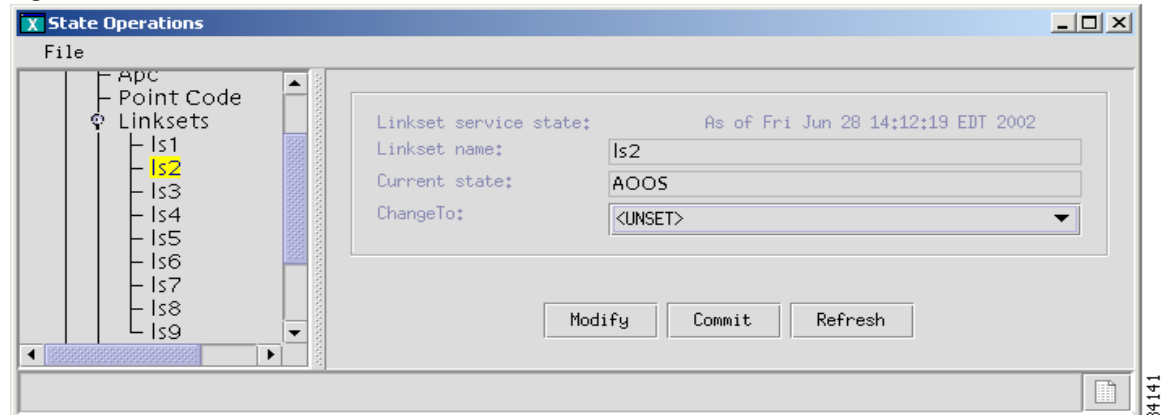

- Step 4** From this window, you can modify the state by selecting the desired state in the **ChangeTo** box. Click **Modify** to change the state in this window, and click **Commit** to change the state on the Cisco MGC. To query the object again, click **Refresh**.

Perform an Audit

You can use an audit to ensure that both the Cisco MGC and a BAMS server supporting the MGC host have consistently configured signal paths. The audit involves examines signal path and bearer channel data on both servers, comparing the data, and reporting any differences.

Use the following procedure to perform an audit:

Step 1 Click **Tools > Audit** on the main VSPT menu. The screen shown in [Figure 3-15](#) appears.

Figure 3-15 Perform an Audit

The screenshot shows a dialog box titled "Audit" with two main sections: "VSC information" and "BAMS information".

VSC information section:

- Hostname:
- Login:
- Password:
- Config:

BAMS information section:

- Hostname:
- Node: (dropdown menu)
- Login:
- Password:
- Config:

At the bottom of the dialog are two buttons: and .

A vertical label "70480" is located on the right side of the dialog box.

Step 1 Enter the MGC hostname, login, and password in the top pane of the window.

Step 2 To specify the configuration to audit, click **Select**, highlight the configuration to audit, and click **OK**.

Step 3 Enter the BAMS hostname, login, and password in the bottom pane of the window.

Step 4 To specify the configuration to audit, click **Select**, highlight the configuration to audit, and click **OK**.

Step 5 Click **Audit**. A screen similar to the one displayed in [Figure 3-16](#) appears.

Figure 3-16 Audit Results

Trunkgrp	# of Circuits	Trunkgrp	# of Circuits
2182	120		
4040	30		
2181	30		
2016	1710		
4012	120		
4011	30		
4010	30		
2012	120		
2011	30		
1221	120		
1021	30		
4032	1200		
2173	60		
4031	120		
2172	30		
4030	30		
2171	30		
1181	30		
3012	210		
1015	1710		
3011	30		
1012	60		

The left pane displays the signal path and bearer channel data configured on the MGC host, and the right pane displays the same data configured on the BAMS server.

Back Up and Restore

The VSPT backup and restore tool allows you to create, modify, and delete scheduled backups and restores hourly, daily, weekly, monthly, or on demand. You can perform back up and restore activities on any of the following devices if they have been configured for the MGC:

- MGC Host—Active configuration
- CAT5500—Configuration and image in Flash
- CAT2900XL—Running-config and image in Flash
- SLT2600—Running-config and image in Flash
- BAMS P2—Active configuration
- BAMS P3—Active configuration
- HSI Adjunct Server—Active configuration

The backup and restore tool also provides the status of each activity and generates user-viewable status logs.



Note

This tool operates in coordination with the MGC server operating system and can be performed by one UNIX login (specified during the installation process).

Schedule a Backup or Restore

To schedule a backup or restore, use the following procedure:

- Step 1** Click **Tools > Backup and Restore** on the main VSPT menu bar. The screen shown in [Figure 3-17](#) appears.

Figure 3-17 Backup and Restore Utility

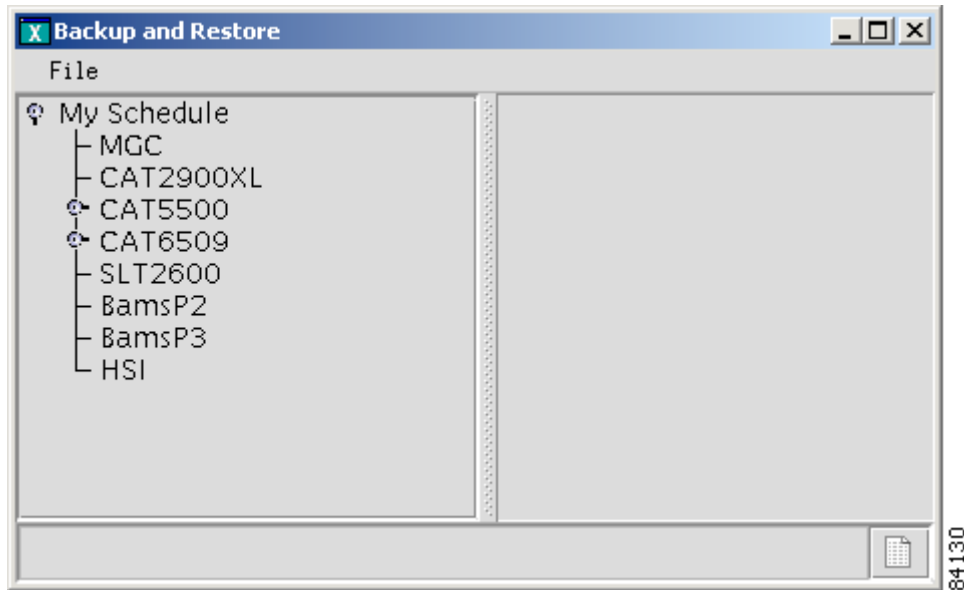

- Step 2** Click the component for which you want to schedule a backup. In the following example, the MGC component configuration is backed up. A screen similar to the one shown in [Figure 3-18](#) appears when you click the MGC component.

Figure 3-18 Scheduling a Backup or Restore

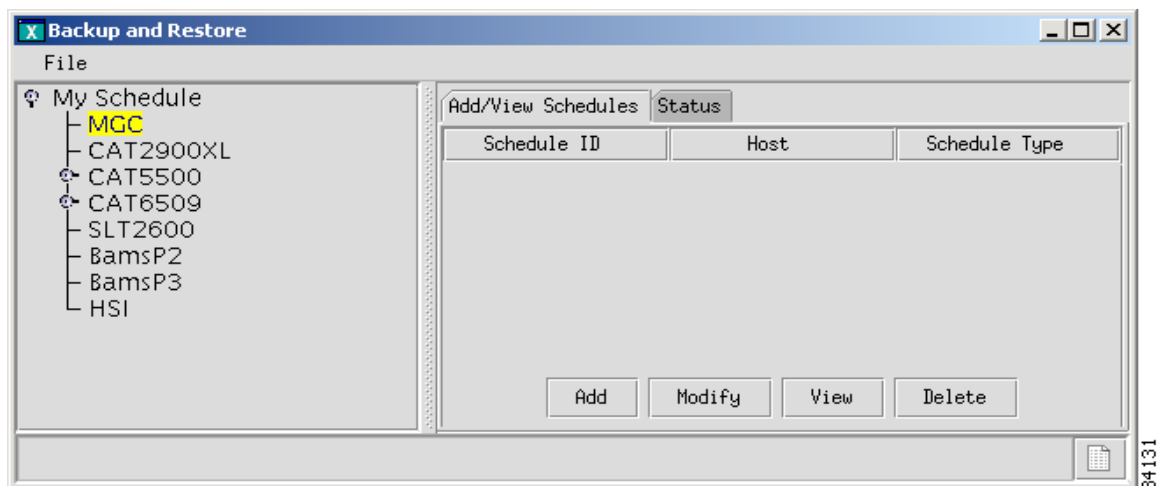



Note If you want to perform a restore, you must have a backup file already created and available on the MGC.

Step 3 Highlight the component you want to back up or restore in the left pane of the main backup and restore tool window, and click **Add**. A screen similar to the one shown in [Figure 3-19](#) appears.

Figure 3-19 Schedule an Activity



Note The fields available on the Schedule an Activity screen vary according to the component selected.

- Step 4** In the Activity field, select the action you want to perform. Choices include backup and restore.
- Step 5** Enter the IP address of the Cisco MGC.
- Step 6** Enter the MGC login and password.
- Step 7** Enter a name for the backup file.
- Step 8** In the File Type drop-down list, select one of the following:
- MGC System—Backs up data files for the active configuration, the Times Ten database, the XEconfigParm.dat file, and UNIX configuration files.
 - MML Config—Backs up exported MML files for the active configuration on the MGC
- Step 9** Enter the IP address of the TFTP server.
- Step 10** Enter the TFTP login and password.
- Step 11** Specify whether or not to use verbose log mode. Verbose mode records all commands issued by the VSPT and any system responses.
- Step 12** Select the schedule type. Choices include:

- Monthly
- Daily
- Hourly
- Weekly
- Now
- Later

Step 13 Select the hour and minute that the backup should begin.

Step 14 Click **OK**. The backup activity is scheduled, and a screen similar to the one shown in [Figure 3-20](#) appears.

Figure 3-20 Display Activity Schedule

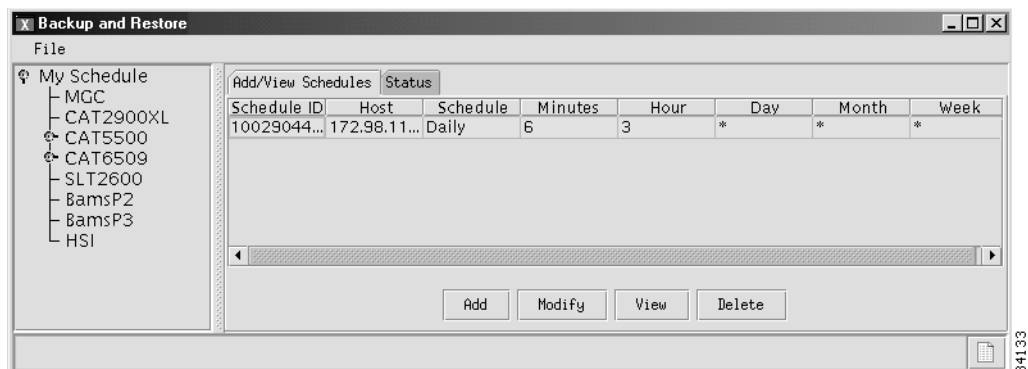

After the backup has been completed, the status of the activity is immediately available. The backup file with the name you specified is available for use with the VSPT.

Check Status of Backup or Restore

The VSPT generates status logs that provide information about each scheduled activity. The status log displays the following information for the activity:

- Date and time when activity began
- Success or failure
- File name on the TFTP server
- Directory of configuration files
- Image file name

If you specified verbose log mode, the status log also displays the sequence of commands issued by the VSPT and any system responses.

Use the following procedure to check the status of a backup or restore activity:

-
- Step 1** In the left pane of the backup and restore tool window, click the device that has been backed up or restored. Click the **Status** tab in the right pane.
- Step 2** Highlight the backup or restore for which you want information.
- Step 3** Select the appropriate button for the action you want to perform. Choices are:

- Show status—Displays the log file for the activity.
 - Acknowledge—Removes the text from the Status window and deletes the log file from the server.
 - Clear—Removes the text from the Status window, but the log file remains on the server.
-

Make a Seed File

A *seed file* is a file created by the VSPT that contains the IP addresses of all of the devices in the Cisco MGC network, plus the relationship (hierarchy) between the devices. With this file, Cisco MNM can automatically deploy all the elements in the network that have been configured with the VSPT.

For information about deploying a seed file, refer to the *Cisco MNM Release 2.1 or 2.3 User's Guide*.

Use the following procedure to make a seed file:

-
- Step 1** Click **Tools > Make a Seed File** on the main VSPT menu. The screen shown in [Figure 3-21](#) appears:

Figure 3-21 Make a Seed File

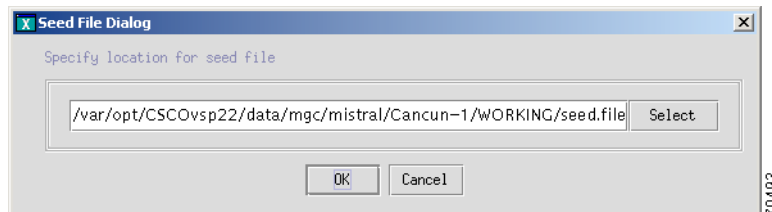

- Step 2** Enter the path and a filename, or click **Select** and specify a directory for the file. You can also choose the default, which is `/var/opt/<basedir>/data/mgc/mistral/<configuration name>/WORKING/seed.file`.
- Step 3** Click **OK**. A seed file is created in the directory you specified.
-



A

- active configuration [2-3](#)
- adapter
 - component [1-9](#)
- adjacent point code [1-9](#)
- APC
 - component [1-9](#)

C

- C7 IP link
 - component [1-9](#)
- cards
 - hardware [1-9](#)
- changing
 - configuration [2-3](#)
- Cisco Voice Services Provisioning Tool [1-4](#)
- committing, configuration [3-6](#)
- component
 - adapter [1-9](#)
 - APC [1-9](#)
 - C7 IP link [1-9](#)
 - external node [1-9](#)
 - ExtNode [1-9, 2-4](#)
 - IP link [1-9](#)
 - linkset [1-9](#)
 - point code [1-9](#)
 - relationships between [1-10](#)
 - SigIPFAS [1-9](#)
 - SigMGCP [1-9](#)
 - SS7 Route [1-9](#)
 - SS7 SubSys [1-9](#)

- SS7SubSys [1-9](#)
- configuration
 - active [2-3](#)
 - changing [2-3](#)
 - committing [3-6](#)
 - deploying [3-6](#)

D

- deploy command [1-13](#)
- deploying, configuration [3-6](#)
- descriptions [1-10](#)
- destination point code [1-9](#)
- documentation, obtaining [x](#)

E

- exit command [1-12](#)
- exiting the VSPT [1-14](#)
- ExtNode component [1-9, 2-4](#)

F

- field names [1-9](#)

H

- Help menu [1-12](#)

I

- interface, Ethernet [1-9](#)
- international network indicator [2-6](#)

INDEX

IP link component [1-9](#)

L

linkset component [1-9](#)

logging in to the VSPT [1-11](#)

login screen [1-11](#)

M

menu

 Session [1-12](#)

 View [1-12](#)

menu bar [1-14](#)

menus [1-12](#)

N

national network indicator [2-6](#)

network indicator [2-6](#)

Number Analysis tab [1-13](#)

O

obtaining documentation [x](#)

origination point code [1-9](#)

P

point oode component [1-9](#)

protocols [2-9](#)

R

reserved network indicator [2-6](#)

S

Session menu [1-12](#)

SigIPFAS component [1-9](#)

SigMGCP component [1-9](#)

spare network indicator [2-6](#)

SS7 route

 component [1-9](#)

SS7SubSys component [1-9](#)

starting

 VSPT [1-11](#)

STP [1-9](#)

STP, mated pair [1-9](#)

sync command [1-12](#)

T

tabs [1-13](#)

 Number Analysis [1-13](#)

 Telephony Controller [1-13](#)

 Traffic [1-13](#)

Telephony Controller tab [1-13](#)

tips, before provisioning [1-4](#)

Traffic tab [1-13](#)

V

View menu [1-12](#)

VSPT

 exiting [1-14](#)

 logging in [1-11](#)

 starting [1-11](#)

X

X-windows [1-11](#)