

# **Multi Technology Network Management (MTNM)**

## **Implementation Statement Templates and Guidelines**

*Release 3.5*



**TMF814A**

---

**Member Evaluation Version 3.1**

**March 2007**

## Notice

No recipient of this document shall in any way interpret this document as representing a position or agreement of TM Forum or its members. This document is a draft working document of TM Forum and is provided solely for comments and evaluation. It is not a Forum Approved Document and is solely circulated for the purposes of assisting TM Forum in the preparation of a final document in furtherance of the aims and mission of TM Forum.

Although it is a copyrighted document of TM Forum:

- Members of TM Forum are only granted the limited copyright waiver to distribute this document within their companies and may not make paper or electronic copies for distribution outside of their companies.
- Non-members of the TM Forum are not permitted to make copies (paper or electronic) of this draft document other than for their internal use for the sole purpose of making comments thereon directly to TM Forum.
- If this document forms part of a supply of information in support of an Industry Group Liaison relationship, the document may only be used as part of the work identified in the Liaison and may not be used or further distributed for any other purposes

Any use of this document by the recipient, other than as set forth specifically herein, is at its own risk, and under no circumstances will TM Forum be liable for direct or indirect damages or any costs or losses resulting from the use of this document by the recipient.

This document is governed by all of the terms and conditions of the Agreement on Intellectual Property Rights between TMForum and its members, and may involve a claim of patent rights by one or more TMForum members or by non-members of TMForum.

Direct inquiries to the TM Forum office:

240 Headquarters Plaza  
East Tower – 10<sup>th</sup> Floor,  
Morristown, NJ 07960 USA  
Tel No. +1 973 944 5100  
Fax No. +1 973 944 5110

TM Forum Web Page [www.tmforum.org](http://www.tmforum.org)

## Table of Contents

<b>NOTICE .....</b>	<b>2</b>
<b>TABLE OF CONTENTS .....</b>	<b>3</b>
<b>LIST OF TABLES .....</b>	<b>9</b>
<b>1 INTRODUCTION .....</b>	<b>12</b>
<b>1.1 How this document will be used .....</b>	<b>12</b>
<b>1.2 Document Structure .....</b>	<b>12</b>
<b>1.3 Updates for Version 3.0.....</b>	<b>13</b>
<b>1.4 Updates for Version 3.5.....</b>	<b>13</b>
<b>2 FUNCTIONAL IMPLEMENTATION STATEMENTS (FIS) .....</b>	<b>14</b>
<b>2.1 Overview .....</b>	<b>14</b>
2.1.1 FIS Template .....	14
2.1.2 Data Types .....	14
2.1.3 Interfaces .....	16
2.1.4 Operations .....	17
2.1.5 Exceptions .....	19
2.1.6 Notifications .....	19
<b>2.2 Alarm Severity Assignment Profile (v3.0) .....</b>	<b>23</b>
2.2.1 Data Types .....	23
2.2.2 Interfaces .....	23
2.2.3 Notifications .....	24
<b>2.3 Call SNC Module (v3.5).....</b>	<b>24</b>
2.3.1 Data Types .....	24
2.3.2 Interfaces .....	26
2.3.3 Notifications .....	26
<b>2.4 Common Module.....</b>	<b>26</b>

## TM FORUM Implementation Statement (IS) Template and Guidelines

2.4.1	Data Types .....	26
2.4.2	Interfaces .....	26
2.4.3	Notifications .....	27
<b>2.5</b>	<b>EmsMgr Module .....</b>	<b>27</b>
2.5.1	Data Types .....	27
2.5.2	Interfaces .....	28
2.5.3	Notifications .....	29
<b>2.6</b>	<b>EMS Session Module.....</b>	<b>29</b>
2.6.1	Data Types .....	29
2.6.2	Interfaces .....	29
2.6.3	Notifications .....	29
<b>2.7</b>	<b>EmsSessionFactory .....</b>	<b>29</b>
2.7.1	Data Types .....	29
2.7.2	Interfaces .....	30
2.7.3	Notifications .....	30
<b>2.8</b>	<b>Equipment Module.....</b>	<b>30</b>
2.8.1	Data Types .....	30
2.8.2	Interfaces .....	33
2.8.3	Notifications .....	34
<b>2.9</b>	<b>FlowDomain Module.....</b>	<b>34</b>
2.9.1	Data Types .....	34
2.9.2	Interfaces .....	38
2.9.3	Notifications .....	39
<b>2.10</b>	<b>FlowDomainFragment Module.....</b>	<b>39</b>
2.10.1	Data Types .....	39
2.10.2	Interfaces .....	41
2.10.3	Notifications .....	41
<b>2.11</b>	<b>Globaldefs Module .....</b>	<b>42</b>
2.11.1	Data Types .....	42
2.11.2	Interfaces .....	42
2.11.3	Notifications .....	42
<b>2.12</b>	<b>GuiCutThrough Module .....</b>	<b>42</b>
2.12.1	Data Types .....	42
2.12.2	Interfaces .....	43

## MTNM IMPLEMENTATION STATEMENT TEMPLATES AND GUIDELINES

2.12.3	Notifications .....	43
<b>2.13</b>	<b>MaintenanceOperations Module .....</b>	<b>43</b>
2.13.1	Data Types .....	43
2.13.2	Interfaces .....	43
2.13.3	Notifications .....	44
<b>2.14</b>	<b>Managed Element Module .....</b>	<b>44</b>
2.14.1	Data Types .....	44
2.14.2	Interfaces .....	45
2.14.3	Notifications .....	45
<b>2.15</b>	<b>ManagedElementManager Module .....</b>	<b>45</b>
2.15.1	Data Types .....	45
2.15.2	Interfaces .....	45
2.15.3	Notifications .....	46
<b>2.16</b>	<b>MLSNPP Module .....</b>	<b>46</b>
2.16.1	Data Types .....	46
2.16.2	Interfaces .....	47
2.16.3	Notifications .....	47
<b>2.17</b>	<b>MLSNPP Link Module .....</b>	<b>47</b>
2.17.1	Data Types .....	47
2.17.2	Interfaces .....	48
2.17.3	Notifications .....	48
<b>2.18</b>	<b>MTNM Version Module .....</b>	<b>49</b>
2.18.1	Data Types .....	49
2.18.2	Interfaces .....	49
2.18.3	Notifications .....	49
<b>2.19</b>	<b>MultiLayerSubnetwork Module .....</b>	<b>49</b>
2.19.1	Data Types .....	49
2.19.2	Interfaces .....	50
2.19.3	Notifications .....	53
<b>2.20</b>	<b>NMS Session Module .....</b>	<b>53</b>
2.20.1	Data Types .....	53
2.20.2	Interfaces .....	53
2.20.3	Notifications .....	53
<b>2.21</b>	<b>Notifications Module .....</b>	<b>54</b>

## TM FORUM Implementation Statement (IS) Template and Guidelines

2.21.1	Data Types .....	54
2.21.2	Interfaces .....	54
2.21.3	Notifications .....	54
<b>2.22</b>	<b>Performance Module.....</b>	<b>54</b>
2.22.1	Data Types .....	54
2.22.2	Interfaces .....	56
2.22.3	Notifications .....	57
<b>2.23</b>	<b>Protection Module.....</b>	<b>57</b>
2.23.1	Data Types .....	57
2.23.2	Interfaces .....	58
2.23.3	Notifications .....	59
<b>2.24</b>	<b>Session Module.....</b>	<b>59</b>
2.24.1	Data Types .....	59
2.24.2	Interfaces .....	59
2.24.3	Notifications .....	59
<b>2.25</b>	<b>SoftwareAndDataManager Module (v3.0) .....</b>	<b>59</b>
2.25.1	Data Types .....	59
2.25.2	Interfaces .....	59
2.25.3	Notifications .....	60
<b>2.26</b>	<b>Subnetwork Connection Module .....</b>	<b>60</b>
2.26.1	Data Types .....	60
2.26.2	Interfaces .....	68
2.26.3	Notifications .....	68
<b>2.27</b>	<b>Termination Point Module .....</b>	<b>68</b>
2.27.1	Data Types .....	68
2.27.2	Interfaces .....	71
2.27.3	Notifications .....	71
<b>2.28</b>	<b>Topological Link Module .....</b>	<b>72</b>
2.28.1	Data Types .....	72
2.28.2	Interfaces .....	73
2.28.3	Notifications .....	73
<b>2.29</b>	<b>Traffic Conditioning Profile Module (v3.5).....</b>	<b>73</b>
2.29.1	Data Types .....	73
2.29.2	Interfaces .....	74

## MTNM IMPLEMENTATION STATEMENT TEMPLATES AND GUIDELINES

2.29.3	Notifications .....	75
<b>2.30</b>	<b>TrafficDescriptor Module.....</b>	<b>75</b>
2.30.1	Data Types .....	75
2.30.2	Interfaces .....	76
2.30.3	Notifications .....	76
<b>2.31</b>	<b>Transmission Descriptor Module (v3.0).....</b>	<b>76</b>
2.31.1	Data Types .....	76
2.31.2	Interfaces .....	78
2.31.3	Notifications .....	79
<b>2.32</b>	<b>Transmission Parameters Module .....</b>	<b>79</b>
2.32.1	Data Types .....	79
2.32.2	Interfaces .....	79
2.32.3	Notifications .....	79
<b>2.33</b>	<b>Miscellaneous.....</b>	<b>79</b>
2.33.1	Version of CORBA and CORBA Services.....	79
2.33.2	Usage of the OMG Notification Service.....	80
2.33.3	Proprietary LayerRates.....	81
2.33.4	SNC Type Transitions Related to the ModifySNC Operation.....	82
<b>3</b>	<b>NON-FUNCTIONAL INTEROPERABILITY STATEMENTS (NIS).....</b>	<b>85</b>
<b>3.1</b>	<b>Iterator Implementation Issues.....</b>	<b>85</b>
<b>3.2</b>	<b>Timing Issues .....</b>	<b>85</b>
<b>4</b>	<b>GUIDELINES.....</b>	<b>87</b>
<b>4.1</b>	<b>Implementation-specific Use Cases .....</b>	<b>87</b>
<b>4.2</b>	<b>EMS Subnetwork Configuration.....</b>	<b>87</b>
<b>4.3</b>	<b>Usage of the Various Resource Names.....</b>	<b>88</b>
<b>4.4</b>	<b>SNC State Representations – Modes.....</b>	<b>90</b>
4.4.1	Mode A .....	90
4.4.2	Mode B .....	91
4.4.3	Mode C .....	91
4.4.4	Mode D .....	91
<b>4.5</b>	<b>Example Probable Cause Template.....</b>	<b>91</b>

TM FORUM Implementation Statement (IS) Template and Guidelines

<b>4.6</b>	<b>Mapping of MTNM Services States to Other Models</b> .....	<b>93</b>
4.6.1	Mapping to Telcordia State Model (GR-1093-CORE).....	93
4.6.2	Mapping to ITU-T States .....	95
<b>4.7</b>	<b>Usage of Network Access Domains (NADs)</b> .....	<b>95</b>
<b>4.8</b>	<b>Root Cause Alarm Indication</b> .....	<b>96</b>
<b>4.9</b>	<b>FTP Examples</b> .....	<b>96</b>
<b>APPENDIX A:TERMS AND ABBREVIATIONS USED WITHIN THIS DOCUMENT</b> .....		<b>104</b>
<b>APPENDIX B:REFERENCES</b> .....		<b>105</b>
<b>ADMINISTRATIVE APPENDIX</b> .....		<b>106</b>
	Use and Extension of a TM Forum Implementation Statement Template and Guidelines.....	106
	Revision History .....	108



## List of Tables

Table 2-1. <Name of Data Type, e.g., Managed Element> .....	14
Table 2-2. Interface Name, e.g., EquipmentInventoryMgr .....	16
Table 2-3. General Iterator Interface .....	17
Table 2-4. Operations Template Example - createAndActivateSNC.....	17
Table 2-5. Exception Table Example - getRoute.....	19
Table 2-6 Probable Cause Template.....	20
Table 2-7. Threshold Template.....	21
Table 2-8. Notifications for Second-Level Objects.....	22
Table 2-9. ASAP .....	23
Table 2-10. Call.....	24
Table 2-11. Call Create Data .....	25
Table 2-12. Call Modify Data .....	25
Table 2-13. Common.....	26
Table 2-14. EMS .....	27
Table 2-15. EMSMgr.....	28
Table 2-16. EmsSession.....	29
Table 2-17. EmsSessionFactory.....	30
Table 2-18. Equipment.....	30
Table 2-19. Equipment Holder .....	31
Table 2-20. Equipment Create Data .....	32
Table 2-21. Equipment Inventory Manager .....	33
Table 2-22. FlowDomain.....	34
Table 2-23. FDCreateData .....	34
Table 2-24. FlowDomain Modify Data .....	35
Table 2-25. MatrixFlowDomain .....	35
Table 2-26. MFDCreateData .....	36
Table 2-27. MatrixFlowDomain Modify Data .....	36
Table 2-28. FTP Create Data .....	37
Table 2-29. Flow Domain Manager.....	38
Table 2-22. FlowDomainFragment .....	39
Table 2-23. FDFrCreateData.....	40

<b>Table 2-24. FlowDomainFragment Modify Data</b> .....	<b>41</b>
<b>Table 2-30. GCTProfileInfo</b> .....	<b>42</b>
<b>Table 2-31. GuiCutThroughData</b> .....	<b>42</b>
<b>Table 2-32. GuiCutThroughMgr</b> .....	<b>43</b>
<b>Table 2-33. CurrentMaintenanceOperation</b> .....	<b>43</b>
<b>Table 2-34. MaintenanceMgr</b> .....	<b>43</b>
<b>Table 2-35. Managed Element</b> .....	<b>44</b>
<b>Table 2-36. ManagedElement Mgr</b> .....	<b>45</b>
<b>Table 2-37. MultiLayerSNPP</b> .....	<b>46</b>
<b>Table 2-38. MLSNPPMgr</b> .....	<b>47</b>
<b>Table 2-39. MultiLayerSNPPLink</b> .....	<b>47</b>
<b>Table 2-40. MLSNPPLinkMgr</b> .....	<b>48</b>
<b>Table 2-41. Version</b> .....	<b>49</b>
<b>Table 2-42. MultiLayerSubnetwork</b> .....	<b>49</b>
<b>Table 2-43. TP Pool Create Data</b> .....	<b>50</b>
<b>Table 2-44. Multi-layer Subnetwork Manager</b> .....	<b>50</b>
<b>Table 2-45. NmsSession</b> .....	<b>53</b>
<b>Table 2-46. PMData</b> .....	<b>54</b>
<b>Table 2-47. PMMeasurement</b> .....	<b>54</b>
<b>Table 2-48. PMThresholdValue</b> .....	<b>55</b>
<b>Table 2-49. PMP (v3.0)</b> .....	<b>55</b>
<b>Table 2-50. PerformanceManagementMgr</b> .....	<b>56</b>
<b>Table 2-51. ProtectionGroup</b> .....	<b>57</b>
<b>Table 2-52. EprotectionGroup (v3.0)</b> .....	<b>57</b>
<b>Table 2-53. ProtectionMgr</b> .....	<b>58</b>
<b>Table 2-54. Session</b> .....	<b>59</b>
<b>Table 2-55. SoftwareAndDataManager</b> .....	<b>59</b>
<b>Table 2-56. Cross Connection</b> .....	<b>60</b>
<b>Table 2-57. SNCCreateData</b> .....	<b>61</b>
<b>Table 2-58. SNC Modify Data</b> .....	<b>63</b>
<b>Table 2-59. Subnetwork Connection</b> .....	<b>65</b>
<b>Table 2-60. Route Create Data (v3.0)</b> .....	<b>67</b>
<b>Table 2-61. Route Descriptor (v3.0)</b> .....	<b>68</b>
<b>Table 2-62. Termination Point</b> .....	<b>69</b>
<b>Table 2-63. Group Termination Point (v3.0)</b> .....	<b>70</b>
<b>Table 2-64. Topological Link</b> .....	<b>72</b>
<b>Table 2-65. TL Create Data (v3.0)</b> .....	<b>72</b>

## MTNM IMPLEMENTATION STATEMENT TEMPLATES AND GUIDELINES

<b>Table 2-66. TCProfile .....</b>	<b>73</b>
<b>Table 2-67. TCProfile Create Data .....</b>	<b>74</b>
<b>Table 2-68. TCProfileMgr .....</b>	<b>74</b>
<b>Table 2-69. Traffic Descriptor .....</b>	<b>75</b>
<b>Table 2-70. TD Create Data .....</b>	<b>75</b>
<b>Table 2-71. TrafficDescriptorMgr .....</b>	<b>76</b>
<b>Table 2-72. Transmission Descriptor.....</b>	<b>76</b>
<b>Table 2-73. TMD Create Data .....</b>	<b>77</b>
<b>Table 2-74. TMD Modification Data .....</b>	<b>78</b>
<b>Table 2-75. TransmissionDescriptorMgr .....</b>	<b>78</b>
<b>Table 2-76. CORBA Version.....</b>	<b>80</b>
<b>Table 2-77. Usage of the Notification Service.....</b>	<b>80</b>
<b>Table 2-78. Proprietary LayerRate Table .....</b>	<b>81</b>
<b>Table 2-79. EMS support for SNC Type Transitions .....</b>	<b>83</b>
<b>Table 3-1. Operations Response Times and Timeouts.....</b>	<b>85</b>
<b>Table 3-2 Heartbeat Time Constraints .....</b>	<b>86</b>
<b>Table 3-3. Heartbeat Notification Time Constraints .....</b>	<b>86</b>
<b>Table 4-1. SNC State Representation Modes.....</b>	<b>90</b>
<b>Table 4-2 Example Probable Cause Template .....</b>	<b>92</b>
<b>Table 4-3 MTNM to Telcordia State Model Mapping.....</b>	<b>93</b>
<b>Table 4-4 ITU-T to MTNM State Mapping .....</b>	<b>95</b>

# 1 Introduction

This document defines an interoperability statement template concerning the use of the TM Forum's MTNM Solution Set Error! Reference source not found.. Specifically, the interoperability statement template provides a mechanism for EMS vendors to precisely state their support for the MTNM interface and for service providers to precisely state their requirements for vendor support of the MTNM interface. The main goal of this document is to facilitate interoperability between parties representing the EMS and NMS sides of the MTNM interface. **The material in this document is not prescriptive.**

## 1.1 How this document will be used

It is expected that this document will be used in several ways:

- (a) As a standard mechanism for service providers to request a specific subset of the MTNM interface capabilities from their vendors
- (b) As a standard mechanism for a management system vendor to state the subset of the MTNM interface capabilities supported by their product(s)
- (c) As a basis for an implementation agreement between 2 or more management system vendors.

## 1.2 Document Structure

The following is a summary of the sections of this document:

- Section 1        Introduces the document
- Section 2        Functional Implementation Statements (FIS) is introduced in this section. An FIS is used to detail vendor support (service provider requirements) for the functions in the MTNM interface.
- Section 3        This section provides templates for Non-functional Implementation Statements (NIS). An NIS is used to describe how a function is supported rather than what functionality is supported. For example, an NIS could describe how long a client should wait for a response to an operation request.

A service provider or vendor preparing an implementation statement would use the templates in Sections 2, 3 and **Error! Reference source not found..** Section 4 is for informational purposes and would not be used directly in preparing an implementation statement.

- Section 4        This section provides guidelines for using the MTNM interface.
- Appendix A      Provides terms and abbreviations used within this document.
- Appendix B      Lists the References.
- Administrative Appendix      This appendix describes the administration of the document.

### **1.3 Updates for Version 3.0**

The following updates were made in going from v2.1 to v3.0:

1. The major set of updates in v3.0 of TMF 814A was to align with v3.0 of TMF 814.
2. Section 5 (Product Profiles) has been removed from v2.1 and a new Section 5 has been added. This new section provides a feature based summary of the capabilities in v2.1 and v3.0. The feature summary comes in the form of a spreadsheet.
3. Add some additional guidelines in Section 4 concerning usage of Network Access Domains (NADs), usage of Root Cause Alarm Indication and some FTP examples.
4. Added subsection to Section 2.27 concerning support for Proprietary LayerRates and SNC Type Transitions Related to the ModifySNC Operation.

### **1.4 Updates for Version 3.5**

The following updates were made in going from v3.0 to v3.5:

1. The major set of updates in v3.5 of TMF 814A was to align with v3.5 of TMF 814, in particular for control plane management and Ethernet management.
2. Editorial update for Section 2.

## 2 Functional Implementation Statements (FIS)

### 2.1 Overview

This section provides Functional Implementation Statement (FIS) templates for the data structures (those that represent objects in the information model), operations and notifications in the MTNM version 3.5 IDL. These templates related to the functional aspects of the operations, notifications and data structures, i.e., whether or not particular capabilities are supported. The non-functional aspects of the operations, notifications and data structures are discussed in Section 3. Functional aspects relate to **what** an entity does, and non-functional aspects related to **how** an entity provides its functionality, e.g., how fast an operation request is fulfilled on average.

#### 2.1.1 FIS Template

The following FIS templates are used for each module:

##### Module Name, e.g., Managed Element

##### Data Types

A template (in the form of a table) needs to be provided for each second-level object associated with the module. The data type template has one row for each attribute of the second-level object.

##### Interfaces

A template (in the form of a table) needs to be provided for each interface associated with the module. The interface template has one row for each operation comprising the interface.

##### Notifications

A template (in the form of a table) needs to be provided for each notification associated with the module. The notification template has one row for each parameter of the notification.

The individual components of the FIS template are explained in the following subsection.

#### 2.1.2 Data Types

There is one table for each second-level object defined in the module.

**Table 2-1.** <Name of Data Type, e.g., Managed Element>

Attribute Name	Set By	Set When and How	Format	Clarification Needed
attribute1, e.g., userLabel	EMS, NMS or E to indicate either	Set When: C, L, A (see the note below for definition of these abbreviations) Set How: List operations that can be used to set the attribute's value. Typically, this field would only be included if the attribute is settable by the NMS.	FREE, FIXED, or VALUE LIST (see the note below for definition of these abbreviations)	The EMS supplier should state the maximum length for the attribute. The NMS supplier should also mention any length requirements.

## MTNM IMPLEMENTATION STATEMENT TEMPLATES AND GUIDELINES

attribute2				
...				

**Conventions:**

Set By – an indication of who can set the attribute.

- “NMS” means only the NMS can set the value,
- “EMS” means only the EMS can set the value, and
- “E” means either the NMS or EMS can set the value

Set When and How – an indication of when and how the attribute can be set.

- “C” (creation) means the attribute can only be set when the managed object is created,
- “L” (lifespan) means the attribute is only set after the managed object is created, and
- “A” (anytime) means the value can be set at creation or anytime thereafter.

Format – the format of the attribute. Possible values are

- “FREE” for Free Format (in this case the vendor or service provide *may* want to provide their supported/required format(s), e.g., CLI™ codes for the nativeEMSName)
- “FIXED” for Fixed Format (the format is defined in the IDL and must be used without variance, and no additional clarification is needed by the vendor or service provider)
- “VALUE LIST” for List (the attribute takes values from a typically long set of possible values defined in the IDL, e.g., layerRate, pmParameterName). In this case, the vendor or service provider *may* want to provide their supported/required set of values, which is a subset of that defined in the IDL plus additional values agreed among the vendors and operators. VALUE LIST is used in only a few places in the following tables. Basically, a VALUE LIST is a data type with a set of supported values.

These three categories are meant to be mutually exclusive.

Clarification Needed – in cases where an attribute may allow for various implementation options, the EMS vendor should state how they are handling the option.

**Remarks:**

All attributes for second-level objects are readable by the NMS. Consequently, there is not a column to indicate whether or not an attribute is readable.

**2.1.3 Interfaces**

There is one table for each interface.

**Table** Error! No text of specified style in document. -2. Interface Name, e.g., EquipmentInventoryMgr

Operation	Status	Support	Exception/ Error Reason	Comments
operation1	M or O	Y, N or C	Exception_Name <error reason	

16\_\_\_\_\_

CLLI and CLEI are trademarks of Telcordia Technologies.



## MTNM IMPLEMENTATION STATEMENT TEMPLATES AND GUIDELINES

			string>
operation2			
...			

### Conventions:

**Status** – an indication of whether or not the operation is mandatory for a particular interface, as defined in the IDL. The status of an operation can be determined from the IDL. If the exception “EXCPT\_NOT\_IMPLEMENTED” is among the allowable exceptions for an operation, then the operation is optional. In this case, an “O” would be placed in the Status field. Otherwise, the operation is mandatory (this is indicated by an “M”).

**Support** – an indication of whether or not an operation is supported by an EMS vendor (required by a service provider). “Y” is used to indicate the operation is supported (required), “N” is used to indicate the operation is not support (not required) and “C” is used if support for an operation is conditional (in this case, an explanation should be included). Note that “Support” field is different than the mandatory/optional indications derived from the IDL. If the implementation statement is prepared by a service provider, the “support” field could be used to indicate a need for capabilities that are implied to be optional in the IDL. Alternately, a vendor could use the “support” field to indicate the MTNM capabilities that they support in their product.

**Exception/Error Reason** – a list of the vendor-specific error reason strings on an operation/exception basis. Recall the MTNM interface provides an error reason field for each exception. It is up to the EMS vendor to decide on the contents of the error reason field. If the error reason strings are long, they can be listed and numbered elsewhere, and then cross-referenced from the table.

**Comments** – this field is used by the EMS vendor to state specific behavioral peculiarities of their implementation of the operation, e.g., to indicate that a particular operation parameter is not supported.

Many of the interfaces have corresponding iterator interfaces. The iterator interfaces are used for the bulk retrieval of data. All of the iterator interfaces have the same operations.

**Table Error! No text of specified style in document.-3. General Iterator Interface**

Operation	Status	Support	Exception/ Error Reason	Comments
destroy	M			
getLength	M			
next_n	M			

### 2.1.4 Operations

The operations template (shown in Table **Error! No text of specified style in document.-4**) is be used when an organization (that is creating a profile of TMF 814) needs to further define characteristics and/or behavior for an operation (beyond that specified in the interface template). A blank cell in the following table implies that the organization completing the template has no further information to provide with regard to the Parameter/Characteristic.

The Comments/Clarifications column is used to further clarify the characteristics and/or usage of the parameter. One can use this column (for example) to indicate the maximum supported length of a parameter, and the default value for a parameter.

It is not anticipated that this template will be needed for all operations.

**Table Error! No text of specified style in document.-4. Operations Template Example - createAndActivateSNC**

TM FORUM Implementation Statement (IS) Template and Guidelines

Parameter	Supported Values	Comments/ Clarifications
<i>createData</i>		
<i>userLabel</i>		Maximum length is 128 characters
<i>forceUniqueness</i>		Not supported by EMS
<i>owner</i>		Maximum length is 128 characters
<i>direction</i>		
<i>staticProtectionLevel</i>	Preemptible Unprotected Partially_Protected Fully_Protected Highly_Protected	Highly_Protected is only used to request DRI in the case of SONET/SDH
<i>protectionEffort</i>		
<i>rerouteAllowed</i>		Not supported
<i>networkRouted</i>		Not supported
<i>sncType</i>	st_simple st_add_drop_a st_add_drop_z st_interconnect st_double_interconnect st_double_add_drop st_open_add_drop st_explicit	
<i>layerRate</i>	LR_VT1_5_and_ TU11_VC11  LR_STS1_and_ AU3_High_Order_VC3	
<i>cclInclusions</i>		
<i>neTpInclusions</i>		
<i>fullRoute</i>		
<i>neTpSncExclusions</i>		Exclusions are not supported
<i>aEnd</i>		
<i>zEnd</i>		
<i>additionalCreation Info</i>		
<i>tolerableImpact</i>	GOI_Major_Impact	
<i>emsFreedomLevel</i>	EMSFL_CC_AT_SNC_LAYER,  EMSFL_TERMINATE_AND_MAP	
<i>tpsToModify</i>		
<i>tpName</i>		

## MTNM IMPLEMENTATION STATEMENT TEMPLATES AND GUIDELINES

<i>tpMappingMode</i>		
<i>transmissionParams</i>	AlarmReporting, PotentialFuture SetupIndicator, TrailTraceActualTx, TrailTraceExpectedRx, TrailTraceMonitor, FrameFormat, LineCode, Mapping, SignalLabel ExpectedRx	
<i>ingressTraffic DescriptorName</i>		Not supported
<i>egressTraffic DescriptorName</i>		Not supported
theSNC		
errorReason		

### 2.1.5 Exceptions

The EMS may raise an exception in response to an MTNM operation request. The allowable exceptions are defined in the IDL. The EMS may also provide an error reason in conjunction with an exception. The allowable error reasons are not defined in the MTNM interface. It is proposed that the following table be used in cases where the EMS supplier wishes to provide further information about their error reasons.

**Table Error! No text of specified style in document.-5. Exception Table Example - getRoute**

Exception	Error Reason	Explanation
EXCPT_NOT_IMPLEMENTED		getRoute is supported in this hypothetical example. So, this exception would never be used.
EXCPT_INTERNAL_ERROR	<ol style="list-style-type: none"> <li>1. EMS is processing other (higher priority requests) and cannot respond to getRoute at this time.</li> <li>2. EMS undergoing system maintenance</li> </ol>	<ol style="list-style-type: none"> <li>1. In some cases, the EMS will reject requests if it is processing higher-priority activities. The NMS should try the request at a later point in time.</li> <li>2. The EMS is undergoing scheduled system maintenance and cannot presently respond to the request.</li> </ol>
EXCPT_INVALID_INPUT		No error reasons are provided with this exception
EXCPT_ENTITY_NOT_FOUND		No error reasons are provided with this exception

### 2.1.6 Notifications

#### 2.1.6.1 Alarms and Probable Causes

The MTNM team has not specified a set of alarms. The team has, however, defined a set of probable causes and does allow for the definition of native probable causes (basically non-MTNM defined probable causes). An alarm type may be uniquely identified by the combination of a **probable cause**, **object type**, and **layer rate**. In

some cases, an additional parameter (i.e., the **probable cause qualifier**) is needed to uniquely identify an alarm. Table Error! No text of specified style in document.-6 is a template that should be used to indicate vendor support for (or service provider need of) probable causes. The table effectively implies all the supported alarms of a vendor, or the required alarms of a service provider.

Not all of the entries in a row need to be filled. The intent is to provide sufficient information to ensure interoperability over the MTNM interface. It is also possible to cover some attributes (e.g., probableCauseQualifier) by providing a general statement before the template, describing how the attribute is used. An example usage of this table is provided in Section 4.5.

The service provider or vendor preparing an implementation statement should place their Probable Cause Template table in this section.

**Table Error! No text of specified style in document.-6 Probable Cause Template**

Probable Cause	Native Probable Cause (Optional)	Associated Object Type	Layer Rates	Probable Cause Qualifiers (optional)	Perceived Severity	Service Affecting	Additional Information (optional)	Comments
Probable Cause #1, e.g., LOS	This attribute represents the equipment vendor's probable cause – this may be mapped to an MTNM probable cause.	Indicate the object types that can be associated with this probable cause	Indicate the layer rates at which this probable cause applies	Indicate the probable cause qualifiers that can be associated with the probable cause	Indicate perceived severity associated with this probable cause – this may depend on the associated object and/or layer rate	Indicate whether or not this probable cause is expected to be service affecting – this may depend on the associated object and/or layer rate	Any additional information and the associated meaning should be noted if it needs to be interpreted by the NMS. The additional information should be listed in the form Name – Value.	This column can be used to provide additional details about the probable cause, e.g., one could describe the conditions under which an alarm is generated by the EMS.
Probable Cause #2								
...								

**2.1.6.1.1 Usage of the Probable Cause Qualifier**

The probableCauseQualifier parameter is useful for two reasons:

It allows the set of values for the probableCause parameter to remain generic. In systems where only one probable cause field is managed, there is a never-ending succession of updates to the set of probable causes. Every time a new equipment type is introduced, new values need to be added. The practical result is that the model is never stabilized.

It allows several alarms to be sent from the same object, with the same probable cause, while still remaining identifiably different. (The alternative would be to manage unique values of the notification identifier, but some EMS vendors have problems with that.)

## MTNM IMPLEMENTATION STATEMENT TEMPLATES AND GUIDELINES

Note that probableCause qualifier is not necessarily human readable, as its real purpose is to satisfy the second point. For instance, if the EMS works internally with a GDMO model, then it might use a GDMO probableCause and specificProblems attribute values (which are sequences of integers, not very exciting to read). The additionalText parameter is there to tell the human operator what is going on.

### **Example 1:**

Consider a vendor that has a line terminal NE that issues the following native alarms from the same termination point and layer rate:

- DegradedSignal
- fecUncorrectedBlocks (meaning that our Reed-Solomon Forward Error Correcting algorithm has rejected some frames)

Both these alarms are mapped to the generic probable cause BER\_SD (i.e., "signal degraded"). The probableCauseQualifier, nativeEMSProbableCause and possibly the additionalText parameters distinguish between the two. Note that this saves one the trouble of going to TM Forum MTNM standards group and asking for a new probableCause value, and even better, it saves the NMS vendor the trouble of managing a new fault condition which from their point of view is equivalent to the other one ("a difference that makes no difference is no difference").

### **Example 2:**

Just consider all the equipment alarms that can be generated by all the equipment vendors. The MTNM interface designers intentionally use a single probableCause value "EQPT" for all of them. The implication is that it is not expected for the NMS to discriminate between hundreds of equipment conditions.

### **2.1.6.2 Threshold Crossing Alerts (TCAs)**

One TCA template should be provided for each supported (or required) PM parameter for which the vendor supports thresholding or the service provider requires thresholding. As was the case for the probable cause template, a single Threshold template can cover several types of TCA (one TCA for each layer rate associated with a PM parameter). It should be noted that for a given PM parameter some parameters in the template may vary based on the layer rate.

**Table Error! No text of specified style in document.-7. Threshold Template**

Parameter	Format	Comments/ Clarifications
notificationId	FREE	The notificationId is not guaranteed to be unique. However, if a vendor does support unique Ids, this should be noted.
objectName	FIXED	
nativeEMSName	FREE	
objectType	VALUE LIST  The set of object types to which this TCA can apply	
emsTime	FIXED	In cases where the NE does not report time, a zero should be returned.
neTime	FIXED	

## TM FORUM Implementation Statement (IS) Template and Guidelines

isClearable	FIXED	
perceivedSeverity	VALUE LIST	The EMS vendor (SP or NMS vendor) should describe the criteria that are used (required) when assigning a perceived severity to a particular alarm.
layerRate	VALUE LIST Service provider (vendor) should indicate the required (supported) layerRates to which this alarm type applies	
granularity	FIXED	
pmParameterName	VALUE LIST	The EMS vendor (SP or NMS vendor) should indicate the set support (required) PM parameters.
pmLocation	FIXED	
thresholdType	FIXED	
value	FREE	
unit	FREE	
Version 3.0 Additions		
acknowledge Indication		

### 2.1.6.3 AVCs, Object Creation/Deletion and Other Notifications

The second-level objects in the MTNM model are expected to emit Attribute Value Change (AVC), Object Creation, Object Deletion, and State Change notifications. Table Error! No text of specified style in document.-8 summarizes the notifications that are to be supported for the second-level objects. The table is based on Section 6 of the MTNM Information Agreement. A party (vendor or service provider) using this implementation statement should indicate any variances from the required MTNM notifications. A notification compliance statement is to be included for each module (see, for example, Sections 2.5.3, 2.6.3, 2.8.3). The notification formats are provided in a supporting document to the MTNM IDL Solution Set (the supporting document is called *Using the Notification and Log Services*).

**Table Error! No text of specified style in document.-8.** Notifications for Second-Level Objects

Notification Type	Notification Producers	Variations from the MTNM Interface Specification
Object Creation	Topological Link, Equipment, Equipment Holder, Subnetwork, Traffic Descriptor, PTP, TP Pool, Subnetwork Connection, Managed Element, Protection Group  (v3.0) ASAP, Equipment Protection Group, Group Termination Point, Log, Transmission Descriptor	

## MTNM IMPLEMENTATION STATEMENT TEMPLATES AND GUIDELINES

Object Deletion	Topological Link, Equipment, Equipment Holder, Subnetwork, Traffic Descriptor, PTP, TP Pool, Subnetwork Connection, Managed Element, Protection Group  (v3.0) ASAP, Equipment Protection Group, Group Termination Point, Log, Transmission Descriptor	
Attribute Value Change (AVC)	Topological Link, Equipment, Equipment Holder, Subnetwork, Traffic Descriptor, PTP, CTP, TP Pool, Subnetwork Connection, Managed Element, Protection Group, EMS  (v3.0) ASAP, Equipment Protection Group, Group Termination Point, Log, Transmission Descriptor	
State Change	Equipment Holder, Equipment, PTP, CTP, Subnetwork Connection, Managed Element, Protection Group  (v3.0) Equipment Protection Group, Group Termination Point, Log	

## 2.2 Alarm Severity Assignment Profile (v3.0)

### 2.2.1 Data Types

**Table Error! No text of specified style in document.-9. ASAP**

Attribute Name	Set By	Set When and How	Format	Clarification Needed
name	EMS	C	FREE	
userLabel	E	A – set by the EMS (C), or by the NMS via createASAP (C) or setUserLabel (L)	FREE	As noted in Section 4.3, userLabel, owner, nativeEMSName can be used in a variety of ways. The EMS vendor (SP) should describe their particular usage of these attributes.
nativeEMSName	E	A – set by the EMS (C), or by the NMS via createASAP (C) or setNativeEMSName (L)	FREE (e.g. CLEI code)	
owner	NMS	L – setOwner	FREE	
notModifiable	EMS	C	FIXED	
alarmSeverityAssignmentList	E	A – set by the EMS (C), or by the NMS via createASAP (C) or modifyASAP (L)	FREE	EMS supplier should indicate range of possible value
additionalInfo	-	-	-	Name/Value list defined by the EMS vendor.  Also, extensions are included in additionalInfo.

### 2.2.2 Interfaces

There is the ASAPIterator interface which is used to retrieve a large number of ASAPs (one batch at a time).

### 2.2.3 Notifications

To be provided by the organization preparing an interoperability statement

## 2.3 Call SNC Module (v3.5)

### 2.3.1 Data Types

Table Error! No text of specified style in document.-10. Call

Attribute Name	Set By	Set When and How	Format	Clarification Needed
callName	E	C	FREE	The callName could be optionally provided by the NMS. If not provided by NMS, it will be set by EMS using the same value as called.
userLabel	NMS	A – set by the NMS via establishCall (C), modifyCall (L), or setUserLabel (L)	FREE	As noted in Section 4.3, userLabel, owner, nativeEMSName can be used in a variety of ways. The EMS vendor (SP) should describe their particular usage of these attributes.
owner	NMS	A – set by the NMS via establishCall (C), modifyCall (L), or setOwner (L)	FREE	The value may be empty.
nativeEMSName	E	A – set by the EMS (C), or by the NMS via establishCall (C) or setNativeEMSName (L)	FREE (e.g. CLEI code)	
networkAccessDomain	NMS	C – set by the NMS via establishCall (C)	FREE	
callId	EMS	C – set by the EMS (control plane)	FREE	The value is provided by the control plane and used for signaling
callState	EMS	A – set by the EMS (C) and updated by the EMS anytime thereafter	FIXED	
aEnd	NMS	C – set by the NMS via establishCall (C)	FIXED	
zEnd	NMS	C – set by the NMS via establishCall (C)	FIXED	
callParameters	NMS	C – set by the NMS via establishCall (C)	FIXED	
callDiversity	NMS	C – set by the NMS via establishCall (C)	FIXED	
diversitySynthesis	EMS	A – set by the EMS (C) and updated by the EMS anytime thereafter	FIXED	
linkDiversityViolationsList	EMS	A – set by the EMS (C) and updated by the EMS anytime thereafter	FIXED	



MTNM IMPLEMENTATION STATEMENT TEMPLATES AND GUIDELINES

nodeDiversityViolationsList	EMS	A – set by the EMS (C) and updated by the EMS anytime thereafter	FIXED	
linkPartialDiversityList	EMS	A – set by the EMS (C) and updated by the EMS anytime thereafter	FIXED	
nodePartialDiversityList	EMS	A – set by the EMS (C) and updated by the EMS anytime thereafter	FIXED	
callAdditionalInfo	NMS	C – set by the NMS via establishCall (C)	--	Name/Value list defined by the EMS vendor.

**Table Error! No text of specified style in document.-11. Call Create Data**

Attribute Name	Set By	Set When and How	Format	Clarification Needed
callName	E	C	FREE	The callName could be optionally provided by the NMS. If not provided by NMS, it will be set by EMS using the same value as called.
userLabel	NMS	A – set by the NMS via establishCall (C), modifyCall (L), or setUserLabel (L)	FREE	As noted in Section 4.3, userLabel, owner, nativeEMSName can be used in a variety of ways. The EMS vendor (SP) should describe their particular usage of these attributes.
forceUniqueness	NMS		FIXED	
owner	NMS	A – set by the NMS via establishCall (C), modifyCall (L), or setOwner (L)	FREE	The value may be empty.
networkAccessDomain	NMS	C – set by the NMS via establishCall (C)	FREE	
aEnd	NMS	C – set by the NMS via establishCall (C)	FIXED	
zEnd	NMS	C – set by the NMS via establishCall (C)	FIXED	
callParameters	NMS	C – set by the NMS via establishCall (C)	FIXED	
callDiversity	NMS	C – set by the NMS via establishCall (C)	FIXED	
additionalCreationInfo	NMS	C – set by the NMS via establishCall (C)	--	Name/Value list defined by the EMS vendor.

**Table Error! No text of specified style in document.-12. Call Modify Data**

Attribute Name	Set By	Set When and How	Format	Clarification Needed
----------------	--------	------------------	--------	----------------------

## TM FORUM Implementation Statement (IS) Template and Guidelines

userLabel	NMS	A – set by the NMS via establishCall (C), modifyCall (L), or setUserLabel (L)	FREE	As noted in Section 4.3, userLabel, owner, nativeEMSName can be used in a variety of ways. The EMS vendor (SP) should describe their particular usage of these attributes.
forceUniqueness	NMS		FIXED	
owner	NMS	A – set by the NMS via establishCall (C), modifyCall (L), or setOwner (L)	FREE	The value may be empty.
networkAccessDomain	NMS	C – set by the NMS via establishCall (C)	FREE	
additionalModificationInfo	NMS	C – set by the NMS via establishCall (C)	--	Name/Value list defined by the EMS vendor.

### 2.3.2 Interfaces

There is the CallAndTopLevelConnectionsIterator interface which is used to retrieve a large number of Calls and their associated Top level connections (one batch at a time).

There is the CallIterator interface which is used to retrieve a large number of Calls (one batch at a time).

### 2.3.3 Notifications

To be provided by the organization preparing an interoperability statement.

## 2.4 Common Module

### 2.4.1 Data Types

This module has no data types that represent second level objects.

### 2.4.2 Interfaces

**Table Error! No text of specified style in document.-13. Common**

Operation	Status	Support	Exception/ Error Reason	Comments
getCapabilities	M			The feature/capability name part is used to identify an IDL operation using the following convention: "module_name::interface_name::operation_name." Other capabilities include Supports_CC_sharing, Supports_pending, and Supports_adjacent_termination_inclusion.
setNativeEMSName	O			
setOwner	O			
setUserLabel	O			
Version 3.0 Additions				

## MTNM IMPLEMENTATION STATEMENT TEMPLATES AND GUIDELINES

setAdditionalInfo	O			
-------------------	---	--	--	--

### 2.4.3 Notifications

There are no specific notifications associated with the data types in this module.

## 2.5 EmsMgr Module

### 2.5.1 Data Types

**Table Error! No text of specified style in document.-14. EMS**

Attribute Name	Set By	Set When and How	Format	Clarification Needed
name	EMS	C	FREE	The Value string that applies to the "ManagedElement", for example, can contain any string as long as it uniquely identifies the Managed Element within the EMS.  The EMS supplier should indicate the maximum length of the attribute (same comments holds true for all attributes).
userLabel	E	A – set by the EMS (C), or by the NMS via setUserLabel (L)	FREE	As noted in Section 4.3, userLabel, owner, nativeEMSName can be used in a variety of ways. The EMS vendor (SP) should describe their particular usage of these attributes.
nativeEMSName	E	A – set by the EMS (C), or by the NMS via setNativeEMSName (L)	FREE (e.g. CLEI code)	
owner	NMS	L – setOwner	FREE	
emsVersion	EMS	A – set at time of EMS initialization and is not expected to change very often	FREE	
type	EMS	A – set at time of EMS initialization and is not expected to change very often	FREE	
additionalInfo	-	-	-	Name/Value list defined by the EMS vendor.  Also, extensions are included in additionalInfo.
Version 3.0 Additions				
ASAPpointer	E	EMS (C), or by the NMS via assignASAP (L)	FIXED	

## 2.5.2 Interfaces

**Table Error! No text of specified style in document.-15.** EMSMgr

Operation	Status	Support	Exception/ Error Reason	Comments
getAllEMSAndMEActiveAlarms	M			
getAllEMSSystemActiveAlarms	M			
getAllTopLevelSubnetworkNames	M			
getAllTopLevelSubnetworks	M			
getAllTopLevelTopologicalLinkNames	O			
getAllTopLevelTopologicalLinks	O			
getTopLevelTopologicalLink	O			
getEMS	M			
Version 3.0 Additions				
acknowledgeAlarms	O			
assignASAP	O			
createASAP	O			
createTopologicalLink	O			
deassignASAP	O			
deleteASAP	O			
deleteTopologicalLink	O			
getAllASAPs	O			
getAllASAPNames	O			
getAllEMSAndMEUnacknowledged ActiveAlarms	O			
getAllEMSSystemUnacknowledged ActiveAlarms	O			
getASAP	O			
getASAPAssociatedResourceNames	O			
getASAPbyResource	O			
modifyASAP	O			
unacknowledgeAlarms	O			
Version 3.5 Additions				
getAllMLRAsandMEs	M			
getAllMLSNPPLinks	O			

## MTNM IMPLEMENTATION STATEMENT TEMPLATES AND GUIDELINES

getAllMLSNPPLinksWithTP	O			
getAllMLSNPPLinksWithMLSNs	O			
getAllMLSNPPLinksWithTNA	O			
getAllMLSNPPs	O			
getAllMLSNPPsWithTP	O			
getAllMLSNPPsWithTNA	O			

### 2.5.3 Notifications

To be provided by the organization preparing an interoperability statement

## 2.6 EMS Session Module

### 2.6.1 Data Types

This module has no data types that represent second level objects.

### 2.6.2 Interfaces

**Table** Error! No text of specified style in document.-16. EmsSession

Operation	Status	Support	Exception/ Error Reason	Comments
getEventChannel	M			
getManager	O			Attempting to gain access to the following manager interfaces may not raise EXCPT_NOT_IMPLEMENTED: EMS, ManagedElement, MultiLayerSubnetwork, GuiCutThrough
getSupportedManagers	M			

### 2.6.3 Notifications

There are no specific notifications associated with the data types in this module.

## 2.7 EmsSessionFactory

### 2.7.1 Data Types

This module has no data types that represent second level objects.

## 2.7.2 Interfaces

**Table Error! No text of specified style in document.-17. EmsSessionFactory**

Operation	Status	Support	Exception/ Error Reason	Comments
getEmsSession	M			This operation is accessed via a user name and password. If this security scheme is used by the EMS vendor, they need define a means of assigning passwords to clients (i.e., NMSs).

## 2.7.3 Notifications

There are no specific notifications associated with the data types in this module.

## 2.8 Equipment Module

### 2.8.1 Data Types

**Table Error! No text of specified style in document.-18. Equipment**

Attribute Name	Set By	Set When and How	Format	Clarification Needed
name	EMS	C	FREE	
userLabel	E	A – set by the EMS (C), or by the NMS via setUserLabel (L)	FREE	As noted in Section 4.3, userLabel, owner, nativeEMSName can be used in a variety of ways. The EMS vendor (SP) should describe their particular usage of these attributes.
nativeEMSName	E	A – set by the EMS (C), or by the NMS via setNativeEMSName (L)	FREE (e.g. CLEI code)	
owner	NMS	A – set at time of object creation via the provisionEquipment operation (C), or via setOwner (L)	FREE	
alarmReportingIndicator	E	A – set by EMS at time of equipment create (C) and may be set anytime thereafter by the NMS using the setAlarmReportingOn and setAlarmReportingOff operations (L)	FIXED	
serviceState	EMS	A	FIXED	
expectedEquipmentObjectType	EMS	C	FREE	
installedEquipmentObjectType	EMS	L	FREE	
installedPartNumber	EMS	C	FREE (a vendor may want to	

MTNM IMPLEMENTATION STATEMENT TEMPLATES AND GUIDELINES

installedVersion	EMS	C	may want to indicate specific formats used for their equipment)	
installedSerialNumber	EMS	C		
additionalInfo	-	-	-	Name/Value list defined by the EMS vendor.  Also, extensions are included in additionalInfo.
Version 3.0 Additions				
ASAPpointer	E	EMS (C), or NMS via provisionEquipment (C) or assignASAP (L)	FIXED	
Manufacturer	E	EMS (C) or NMS via provisionEquipment (C)	FREE	
ProtectionRole	E	EMS (C), or NMS via provisionEquipment (C) or setAdditionalInfo (L)	FIXED	
ProtectionSchemeState	E	EMS (C), or NMS via provisionEquipment (C) or setAdditionalInfo (L)	FIXED	

**Table Error! No text of specified style in document.-19. Equipment Holder**

Attribute Name	Set By	Set When and How	Format	Clarification Needed
name	EMS	C	FREE	
userLabel	E	A – set by the EMS (C), or by the NMS via setUserLabel (L)	FREE	As noted in Section 4.3, userLabel, owner, nativeEMSName can be used in a variety of ways. The EMS vendor (SP) should describe their particular usage of these attributes.
nativeEMSName	E	A – set by the EMS (C) or by the NMS via setNativeEMSName (L)	FREE (e.g. CLEI code)	
owner	NMS	L – setOwner	FREE	
alarmReportingIndicator	E	A – set by EMS at time of equipment create (C) and may be set anytime thereafter by the NMS using the setAlarmReportingOn and setAlarmReportingOff operations (L)	FIXED	
holderType	EMS	C	FIXED	
expectedOrInstalledEquipment  (this attribute provides the name of the expected or installed equipment, not the type)	NMS	L – the NMS provisions the installed equipment	FIXED	

## TM FORUM Implementation Statement (IS) Template and Guidelines

acceptableEquipmentTypeList	EMS	A – the EMS indicates the type of equipment that can be supported by the equipment holder (presumably this can change over time)	FREE	This is a list provided at run time by the equipment holder, each equipment holder may support a different set of equipment types. The NMS should be able to handle almost any list being returned in this attribute.  Normally the maximum list size or maximum length of a string element within the list should be sufficient.
holderState	EMS	A	FIXED	
additionalInfo	-	-	-	Name/Value list defined by the EMS vendor.  Also, extensions are included in additionalInfo.
Version 3.0 Additions				
ASAPpointer	E	EMS (C), or by the NMS via assignASAP (L)	FIXED	

**Table Error! No text of specified style in document.-20. Equipment Create Data**

Attribute Name	Set By	Set When and How	Format	Clarification Needed
userLabel	NMS	C – provisionEquipment	FREE	
forceUniqueness	NMS	C – provisionEquipment	FIXED	
owner	NMS	C – provisionEquipment	FREE	
expectedEquipmentObjectType	NMS	C – provisionEquipment	FREE	
equipmentHolderName	NMS	C – provisionEquipment	FREE	
additionalInfo	NMS	C – provisionEquipment	FREE	
Version 3.0 Additions				
AlarmReporting	NMS	C – provisionEquipment	FIXED	
ASAPpointer	NMS	C – provisionEquipment	FIXED	
Manufacturer	NMS	C – provisionEquipment	FREE	
ProtectionRole	NMS	C – provisionEquipment	FIXED	
ProtectionSchemeState	NMS	C – provisionEquipment	FIXED	



2.8.2 Interfaces

**Table** Error! No text of specified style in document.-21. Equipment Inventory Manager

Operation	Status	Support	Exception/ Error Reason	Comments
getAllEquipment	M			
getAllEquipmentNames	M			
getAllSupportedPTPNames	M			
getAllSupportedPTPs	M			
getAllSupportingEquipment	M			
getAllSupporting EquipmentNames	M			
getContainedEquipment	M			
getEquipment	M			
provisionEquipment	O			This operation is commonly used in cases where the EMS does not support auto-provisioning (i.e., an image of the equipment is created in the EMS database when a piece of equipment is inserted into an equipment holder) and GUI Cut Through is not used to provision equipment.
setAlarmReportingOff	O			Equipment providers should indicate whether monitoring is disabled, and indicate whether this is at the NE or at the EMS.
setAlarmReportingOn	O			Equipment providers should indicate whether monitoring is enabled, and indicate whether this is at the NE or at the EMS.
unprovisionEquipment	O			This operation is commonly used in cases where the EMS does not support auto-unassignment (i.e., the image of the equipment is deleted from the EMS database when a piece of equipment is removed from an equipment holder) and GUI Cut Through is not used to unprovision equipment.
Version 3.0 Additions				
getSupportedEquipment	O			
getSupportedEquipment Names	O			
getSupportingEquipment	O			
getSupportingEquipment Names	O			

There is also an EquipmentOrHolderIterator interface. This interface is similar to all the other iterator interfaces.

### 2.8.3 Notifications

To be provided by the organization preparing an interoperability statement

## 2.9 FlowDomain Module

### 2.9.1 Data Types

**Table Error! No text of specified style in document.-22.** FlowDomain

Attribute Name	Set By	Set When and How	Format	Clarification Needed
name	EMS	C	FREE	
userLabel	E	A – set by the EMS (C), or by the NMS via setUserLabel (L)	FREE	As noted in Section 4.3, userLabel, owner, nativeEMSName can be used in a variety of ways. The EMS vendor (SP) should describe their particular usage of these attributes.
nativeEMSName	E	A – set by the EMS (C), or by the NMS via setNativeEMSName (L)	FREE (e.g. CLEI code)	
owner	NMS	L – setOwner	FREE	
transmissionParams	E	A – set by the EMS or NMS (C), or modified via modifyFlowDomain (L)	VALUE LIST	EMS vendor (SP or NMS vendor) should indicated supported (required) transmissionParams and associated values
networkAccessDomain	E	EMS (C) or NMS via setAdditionalInfo (L) or modifyFlowDomain (L)	FREE	
fdConnectivityState	EMS	A	VALUE LIST	
fdType	EMS	C	VALUE LIST	Read-only attribute
additionalInfo	-	-	-	Name/Value list defined by the EMS vendor. Also, extensions are included in additionalInfo.

**Table Error! No text of specified style in document.-23.** FDCreateData

Attribute Name	Set By	Set When and How	Format	Clarification Needed
name	NMS	C – createFlowDomain	FREE	
userLabel	NMS	A – createFlowDomain (C), modifyFlowDomain (L)	FREE	
forceUniqueness	NMS	C – createFlowDomain	FIXED	
owner	NMS	A – createFlowDomain (C), modifyFlowDomain (L)	FREE	

MTNM IMPLEMENTATION STATEMENT TEMPLATES AND GUIDELINES

networkAccess Domain	NMS	A – createFlowDomain (C), modifyFlowDomain (L)	FREE	
mfds	NMS	C – createFlowDomain	VALUE LIST	Not an attribute of the created object. Instead, this information is retrieved by operations getAllAssociatedMFDs , getAssociatingFD , and changed by operations associateMFDsWithFlowDomain, deAssociateMFDsFromFlowDomain.
transmissionParams	NMS	A – set by the EMS or NMS (C), or modified via modifyFlowDomain (L)	VALUE LIST	EMS vendor (SP or NMS vendor) should indicated supported (required) transmissionParams and associated values
additionalCreationInfo	NMS	A – createFlowDomain (C), modifyFlowDomain (L)		Corresponds to additionalInfo attribute of the managed object.

**Table Error! No text of specified style in document.-24. FlowDomain Modify Data**

Attribute Name	Set By	Set When and How	Format	Clarification Needed
userLabel	NMS	A – createFlowDomain (C), modifyFlowDomain (L)	FREE	
forceUniqueness	NMS	C – modifyFlowDomain	FIXED	
owner	NMS	A – createFlowDomain (C), modifyFlowDomain (L)	FREE	
networkAccess Domain	NMS	A – createFlowDomain (C), modifyFlowDomain (L)	FREE	
transmissionParams	NMS	A – set by the EMS or NMS (C), or modified via modifyFlowDomain (L)	VALUE LIST	EMS vendor (SP or NMS vendor) should indicated supported (required) transmissionParams and associated values
additionalModificationInfo	NMS	A – createFlowDomain (C), modifyFlowDomain (L)		Corresponds to additionalInfo attribute of the managed object.

**Table Error! No text of specified style in document.-25. MatrixFlowDomain**

Attribute Name	Set By	Set When and How	Format	Clarification Needed
name	E	C	FREE	

## TM FORUM Implementation Statement (IS) Template and Guidelines

userLabel	E	A – set by the EMS (C), or by the NMS via setUserLabel (L)	FREE	As noted in Section 4.3, userLabel, owner, nativeEMSName can be used in a variety of ways. The EMS vendor (SP) should describe their particular usage of these attributes.
nativeEMSName	E	A – set by the EMS (C), or by the NMS via setNativeEMSName (L)	FREE (e.g. CLEI code)	
owner	NMS	L – setOwner	FREE	
transmissionParams	E	A – set by the EMS or NMS (C), or modified via modifyMFD (L)	VALUE LIST	EMS vendor (SP or NMS vendor) should indicate supported (required) transmissionParams and associated values
networkAccessDomain	E	A – set by EMS (C) or NMS via setAdditionalInfo (L) or modifyMFD (L)	FREE	
flexible	EMS	C	FIXED	Read-only attribute
additionalInfo	NMS	A – createMFD (C), modifyMFD (L)	-	Name/Value list defined by the EMS vendor.  Also, extensions are included in additionalInfo.

**Table Error! No text of specified style in document.-26. MFDCreateData**

Attribute Name	Set By	Set When and How	Format	Clarification Needed
name	NMS	C	FREE	
userLabel	NMS	A – createMFD (C), modifyMFD (L)	FREE	
forceUniqueness	NMS		FIXED	
owner	NMS	A – createMFD (C), modifyMFD (L)	FREE	
networkAccessDomain	NMS	A – createMFD (C), modifyMFD (L)	FREE	
unassignedCPTPs	NMS	C	FIXED	
transmissionParams	E	A – createMFD (C), modifyMFD (L)	FIXED	
additionalCreationInfo	NMS		VALUE LIST	Corresponds to additionalInfo attribute of the managed object.

**Table Error! No text of specified style in document.-27. MatrixFlowDomain Modify Data**

**MTNM IMPLEMENTATION STATEMENT TEMPLATES AND GUIDELINES**

<b>Attribute Name</b>	<b>Set By</b>	<b>Set When and How</b>	<b>Format</b>	<b>Clarification Needed</b>
userLabel	NMS	A – createMFD (C), modifyMFD (L)	FREE	
forceUniqueness	NMS	C – modifyMFD	FIXED	
owner	NMS	A – createMFD (C), modifyMFD (L)	FREE	
networkAccess Domain	NMS	A – createMFD (C), modifyMFD (L)	FREE	
transmissionParams	NMS	A – createMFD (C), modifyMFD (L)	VALUE LIST	EMS vendor (SP or NMS vendor) should indicated supported (required) transmissionParams and associated values

**Note:** additionalModificationInfo is an “inout” parameter of the modifyMFD operation, but not an attribute of MatrixFlowDomain Modify Data.

**Table Error! No text of specified style in document.-28. FTP Create Data**

<b>Attribute Name</b>	<b>Set By</b>	<b>Set When and How</b>	<b>Format</b>	<b>Clarification Needed</b>
equipmentName	NMS	C - createFTP	FREE	
userLabel	E	A – set by EMS (C), by NMS via createFTP (C) or via setUserLabel (L)	FREE	
forceUniqueness	NMS	C	FIXED	
owner	NMS	A – set by EMS (C), by NMS via createFTP (C) or via setOwner (L)	FREE	
ingressTransmissionDescriptorName	NMS	A – createFTP (C) or setTPData (L), or via side effect through activateSNC, deactivateAndDeleteSNC, deactivateSNC (C)	FIXED	
egressTransmissionDescriptorName	NMS		FIXED	
networkAccess Domain	NMS	A – createMFD (C), setTPDate (L)	FREE	In the terminationPoint object, this is part of additionalInfo
tpMappingMode	E	A – by NMS via createFTP (C) or setTPData (L), or via side effect through activateSNC, deactivateAndDeleteSNC, deactivateSNC (C)  Can also be set by the EMS	FIXED	

## TM FORUM Implementation Statement (IS) Template and Guidelines

direction	E	C – via createFTP or via side effect through any of the SNC establishment operations  Can also be set by the EMS	FIXED	
transmissionParams	E	A (depends on the specific transmission parameter) – via createFTP (C), via setTPData (L), or via side effect through activateSNC, deactivateAndDeleteSNC, deactivateSNC (C)	VALUE LIST	EMS vendor (SP or NMS vendor) should indicate supported (required) transmissionParams and associated values
additionalCreationInfo	E	A	VALUE LIST	Corresponds to additionalInfo attribute of the managed object.

### 2.9.2 Interfaces

The EMS supplier should indicate which of the 4 SNC modes of operation it can support (see Section 4.4 for a description of the SNC modes of operation). The NMS supplier should also indicate which mode(s) it can support.

**Table** Error! No text of specified style in document. -29. Flow Domain Manager

Operation	Status	Support	Exception/ Error Reason	Comments
getAllFlowDomains	O			
getFlowDomainsByUserLabel	O			
getFlowDomain	O			
getAssociatingFD	O			
getTransmissionParams	O			
createFlowDomain	O			
deleteFlowDomain	O			
modifyFlowDomain	O			
associateMFDsWithFlowDomain	O			
deAssociateMFDsFromFlowDomain	O			
associateCPTPsWithFlowDomain	O			
deAssociateCPTPsFromFlowDomain	O			
getAllAssociatedMFDs	O			

## MTNM IMPLEMENTATION STATEMENT TEMPLATES AND GUIDELINES

getAllSupportedMFDs	O			
getMFD	O			
getAssigningMFD	O			
createMFD	O			
deleteMFD	O			
modifyMFD	O			
assignCPTPsToMFD	O			
unassignCPTPsFromMFD	O			
createFTP	O			
deleteFTP	O			
getAllCPTPs	O			
getAllAssignedCPTPs	O			
getAllAssignableCPTPs	O			
getAllFDFrs	O			
getFDFrsWithTP	O			
getFDFrsByUserLabel	O			
getFDFr	O			
createAndActivateFDFr	O			
deactivateAndDeleteFDFr	O			
modifyFDFr	O			
getAllTopologicalLinksOfFD	O			
getFDFrRoute	O			

### 2.9.3 Notifications

To be provided by the organization preparing an interoperability statement

## 2.10 FlowDomainFragment Module

### 2.10.1 Data Types

**Table** Error! No text of specified style in document.-30. FlowDomainFragment

Attribute Name	Set By	Set When and How	Format	Clarification Needed
name	EMS	C	FREE	
userLabel	E	A – set by the EMS (C), or by the NMS via setUserLabel (L)	FREE	As noted in Section 4.3, userLabel, owner, nativeEMSName can be used

## TM FORUM Implementation Statement (IS) Template and Guidelines

nativeEMSName	E	A – set by the EMS (C), or by the NMS via setNativeEMSName (L)	FREE (e.g. CLEI code)	in a variety of ways. The EMS vendor (SP) should describe their particular usage of these attributes.
owner	NMS	L – setOwner	FREE	
direction	E	C	FIXED	
transmissionParams	E	A – set by the EMS or NMS (C), or modified via modifyFlowDomain (L)	VALUE LIST	EMS vendor (SP or NMS vendor) should indicated supported (required) transmissionParams and associated values
aEnd	E	C	FIXED	
zEnd	E	C	FIXED	
networkAccessDomain	E	EMS (C) or NMS via setAdditionalInfo (L) or modifyFlowDomain (L)	FREE	
flexible	EMS	C	FIXED	
administrativeState	E	A – set by the EMS or NMS (C), or modified via modifyFDfr (L)	FIXED	
fdfrState	EMS	A	FIXED	
fdfrType	E	C	VALUE LIST	Read-only attribute
additionalInfo	-	-	-	Name/Value list defined by the EMS vendor. Also, extensions are included in additionalInfo.

**Table Error! No text of specified style in document.-31. FDFrCreateData**

Attribute Name	Set By	Set When and How	Format	Clarification Needed
name	NMS	C – createAndAcivateFDfr	FREE	
userLabel	NMS	C – createAndAcivateFDfr	FREE	
forceUniqueness	NMS	C – createAndAcivateFDfr	FIXED	
owner	NMS	C – createAndAcivateFDfr	FREE	
networkAccessDomain	NMS	C – createAndAcivateFDfr	FREE	
direction	NMS	C – createAndAcivateFDfr	FIXED	
administrativeState	NMS	C – createAndAcivateFDfr	FIXED	
transmissionParams	NMS	C – createAndAcivateFDfr	VALUE LIST	EMS vendor (SP or NMS vendor) should indicated supported (required) transmissionParams and associated values



## MTNM IMPLEMENTATION STATEMENT TEMPLATES AND GUIDELINES

fullRoute	NMS	C – createAndAcivateFDFr	FIXED	
fdfrType	NMS	C – createAndAcivateFDFr	FIXED	
additional CreationInfo	NMS	C – createAndAcivateFDFr		Corresponds to additionalInfo attribute of the managed object.

**Table Error! No text of specified style in document.-32. FlowDomainFragment Modify Data**

Attribute Name	Set By	Set When and How	Format	Clarification Needed
userLabel	NMS	L – modifyFDFr (L)	FREE	
forceUniqueness	NMS	L – modifyFDFr (L)	FIXED	
owner	NMS	L – modifyFDFr (L)	FREE	
networkAccess Domain	NMS	L – modifyFDFr (L)	FREE	
administrativeState	NMS	L – modifyFDFr (L)	FIXED	
transmissionParameters	NMS	L – modifyFDFr (L)	VALUE LIST	EMS vendor (SP or NMS vendor) should indicated supported (required) transmissionParams and associated values
tpNamesToRemove	NMS	L – modifyFDFr (L)	FIXED	
aEndTPNames	NMS	L – modifyFDFr (L)	FIXED	
zEndTPNames	NMS	L – modifyFDFr (L)	FIXED	
internalTPNames	NMS	L – modifyFDFr (L)	FIXED	
additional ModificationInfo	NMS	L – modifyFDFr (L)		Corresponds to additionalInfo attribute of the managed object.

### 2.10.2 Interfaces

This module has no regular interface. There is only the MFDFrInterator and FDFrIterator interfaces which are used in conjunction with the various operations that return a list of Matrix Flow Domain Fragment and Flow Domain Fragment.

### 2.10.3 Notifications

To be provided by the organization preparing an interoperability statement.

## 2.11 Globaldefs Module

### 2.11.1 Data Types

This module has no data types that represent second level objects.

### 2.11.2 Interfaces

This module has no “regular” interfaces. There is only the NamingAttributesIterator interface which is used in conjunction with the various operations that return a list of object names, e.g., getAllTopLevelSubnetworkNames.

### 2.11.3 Notifications

There are no specific notifications associated with the data types in this module.

## 2.12 GuiCutThrough Module

### 2.12.1 Data Types

**Table Error! No text of specified style in document.-33. GCTProfileInfo**

Attribute Name	Set By	Set When and How	Format	Clarification Needed
serverLaunchCapability	EMS	A – although unlikely, the EMS can change the value of this attribute	FIXED	
gctHostname	EMS	A – presumable the EMS can change the value of gctHostname	FREE	The information is described in the IDL but format is not.
emsGctPlatform	EMS	A – although unlikely, the EMS can change the value of this attribute	FIXED (string with possible values: "unix", "windowsNT", "local", "web-based")	
guiCutThroughDataList	EMS	A – although unlikely, the EMS can change the value of this attribute	See the GuiCutThroughData table below	

**Table Error! No text of specified style in document.-34. GuiCutThroughData**

Attribute Name	Set By	Set When and How	Format	Clarification Needed
gctScope	EMS	A – although unlikely, the EMS can change the value of these attributes	FIXED	
gctContext	EMS		FIXED	
gctCommand	EMS		FREE	
additionalInfo	E	A – set by EMS (C), or by the NMS via setAdditionalInfo	FREE	

**2.12.2 Interfaces**

**Table Error! No text of specified style in document.-35. GuiCutThroughMgr**

Operation	Status	Support	Exception/ Error Reason	Comments
destroyGCT	O			
getGCTProfileInfo	M			
launchGCT	O			

**2.12.3 Notifications**

There are no specific notifications associated with the data types in this module.

**2.13 MaintenanceOperations Module**

**2.13.1 Data Types**

**Table Error! No text of specified style in document.-36. CurrentMaintenanceOperation**

Attribute Name	Set By	Set When and How	Format	Clarification Needed
tpName	EMS	Set by the EMS when the NMS requests a persistent maintenance command for a given TP via the performMaintenanceOperation operation.	FIXED	
maintenanceOperation	EMS	Set by the EMS when the NMS requests a persistent maintenance command for a given TP via the performMaintenanceOperation operation.	FIXED	
layerRate	EMS	Set by the EMS when the NMS requests a persistent maintenance command for a given TP via the performMaintenanceOperation operation.	VALUE LIST	
additionalInfo	E	A – set by EMS (C), or by the NMS via setAdditionalInfo	FREE	Name/Value list defined by the EMS vendor

**2.13.2 Interfaces**

**Table Error! No text of specified style in document.-37. MaintenanceMgr**

Operation	Status	Support	Exception/ Error Reason	Comments
getActiveMaintenanceOperations	O			
performMaintenanceOperation	O			The EMS vendor (SP or NMS vendor) should indicate supported (required) maintenance operations.

There is also the CurrentMaintenanceOperationIterator, which is used to retrieve a large number of data objects associated with persistent maintenance operations.

### 2.13.3 Notifications

There are no specific notifications associated with the data types in this module.

## 2.14 Managed Element Module

### 2.14.1 Data Types

**Table Error! No text of specified style in document.-38. Managed Element**

Attribute Name	Set By	Set When and How	Format	Clarification Needed
name	EMS	C	FREE	
userLabel	E	A – set by the EMS (C), or by the NMS via setUserLabel (L)	FREE	As noted in Section 4.3, userLabel, owner, nativeEMSName can be used in a variety of ways. The EMS vendor (SP) should describe their particular usage of these attributes.
nativeEMSName	E	A – set by the EMS (C), or by the NMS via setNativeEMSName (L)	FREE (e.g. CLEI code)	
owner	NMS	L – setOwner	FREE	
location	EMS	C	FREE (e.g., CLLI code)	
version	EMS	C	FREE	
productName	EMS	C	FREE	
communicationState	EMS	L	FIXED	
emsInSyncState	EMS	L	FIXED	
supportedRates	EMS	A	VALUE LIST (e.g., LR_Low_Order_TU3_VC3, LR_STS1_and_AU3_High_Order_VC3, LR_STS3c_and_AU4_VC4)	
additionalInfo	-	-	-	Name/Value list defined by the EMS vendor.  Also, extensions are included in additionalInfo.
Version 3.0 Additions (“Set By” and “Set When And How” have the same value for all additionalInfo)				
ASAPpointer	E	EMS (C), or by the NMS via assignASAP (L)	FIXED	
Manufacturer	E	EMS (C) or NMS via setAdditionalInfo (L)	FREE	
NetworkAccess Domain	E	EMS (C), or NMS via setAdditionalInfo (L)	FREE	

## MTNM IMPLEMENTATION STATEMENT TEMPLATES AND GUIDELINES

Domain		setAdditionalInfo (L)	
--------	--	-----------------------	--

### 2.14.2 Interfaces

There are no interfaces other than the ManagedElementIterator, which is used to retrieve a large number of ME data objects.

### 2.14.3 Notifications

To be provided by the organization preparing an interoperability statement

## 2.15 ManagedElementManager Module

### 2.15.1 Data Types

This module has no data types that represent second level objects.

### 2.15.2 Interfaces

**Table Error! No text of specified style in document.-39. ManagedElement Mgr**

Operation	Status	Support	Exception/ Error Reason	Comments
getAllActiveAlarms	M			
getAllCrossConnections	M			
getAllManagedElementNames	M			
getAllManagedElements	M			
getAllIPTPNames	M			
getAllIPTPs	M			
getContainedCurrentTPNames	O			
getContainedCurrentTPs	O			
getContainedInUseTPNames	M			
getContainedInUseTPs	M			
getContainedPotentialTPNames	M			
getContainedPotentialTPs	M			
getContainingSubnetworkNames	M			
getContainingTPNames	M			
getContainingTPs	M			

## TM FORUM Implementation Statement (IS) Template and Guidelines

getManagedElement	M			
getTP	M			
setTPData	M			
Version 3.0 Additions				
createGTP	O			
deleteGTP	O			
getAllFixedCrossConnections	O			
getAllFTPNames	O			
getAllFTPs	O			
getAllGTPNames	O			
getAllGTPs	O			
getAllIPTPNamesWithoutFTPs	O			
getAllIPTPsWithoutFTPs	O			
getAllUnacknowledgedActiveAlarms	O			
getContainingGTP	O			
getGTP	O			
getPotentialFixedCCs	O			
modifyGTP	O			
setGtpAlarmReportingOff	O			
setGtpAlarmReportingOn	O			
verifyTMDAssignment	O			

### 2.15.3 Notifications

There are no specific notifications associated with the data types in this module.

## 2.16 MLSNPP Module

### 2.16.1 Data Types

**Table Error! No text of specified style in document.-40. MultiLayerSNPP**

Attribute Name	Set By	Set When and How	Format	Clarification Needed
name	EMS	C	FREE	
userLabel	E	A – set by the EMS (C) or by the NMS via setUserLabel (L)	FREE	As noted in Section 4.3, userLabel, owner, nativeEMSName can

## MTNM IMPLEMENTATION STATEMENT TEMPLATES AND GUIDELINES

owner	E	A – set by the EMS (C) or by the NMS via setOwner (L)	FREE	be used in a variety of ways. The EMS vendor (SP) should describe their particular usage of these attributes.
nativeEMSName	E	A – set by the EMS (C) or by the NMS via setNativeEMSName (L)	FREE (e.g. CLEI code)	
mLSNPPAliasList	EMS	C	FIXED	
direction	EMS	C	FIXED	
layeredSNPPList	EMS	C	FIXED	
additionalInfo	-	-	-	Name/Value list defined by the EMS vendor. Also, extensions are included in additionalInfo

### 2.16.2 Interfaces

**Table Error! No text of specified style in document.-41. MLSNPPMgr**

Operation	Status	Support	Exception/ Error Reason	Comments
setTNANameForMLSNPP	O			

### 2.16.3 Notifications

There are no specific notifications associated with the data types in this module.

## 2.17 MLSNPP Link Module

### 2.17.1 Data Types

**Table Error! No text of specified style in document.-42. MultiLayerSNPPLink**

Attribute Name	Set By	Set When and How	Format	Clarification Needed
name	EMS	C	FREE	
userLabel	E	A – set by the EMS (C) or by the NMS via setUserLabel (L)	FREE	As noted in Section 4.3, userLabel, owner, nativeEMSName can be used in a variety of ways. The EMS vendor (SP) should describe their particular usage of these attributes.
owner	E	A – set by the EMS (C) or by the NMS via setOwner (L)	FREE	
nativeEMSName	E	A – set by the EMS (C) or by the NMS via setNativeEMSName (L)	FREE (e.g. CLEI code)	
direction	EMS	C	FIXED	
aMLRAName	EMS	C	FIXED	
zMLRAName	EMS	C	FIXED	
sNPPLinkList	EMS	C	FIXED	
interfaceType	EMS	C	FIXED	

## TM FORUM Implementation Statement (IS) Template and Guidelines

signallingParameters	E	A – set by the EMS (C) or by the NMS via setSignallingProtocolAndParameters (L) or modifySignallingProtocolParameters (L)	VALUE LIST	NVSList
signallingControllerIdentifier	E	A – set by the EMS (C) or by the NMS via assignSignallingController (L) or deassignSignallingController (L)	FREE	
signallingProtocol	E	A – set by the EMS (C) or by the NMS via setSignallingProtocolAndParameters (L)	FIXED	
signallingEnabled	E	A – set by the EMS (C) or by the NMS via enableSignalling (L) or disableSignalling (L)	FIXED	
cost	EMS	C	VALUE LIST	NVSList
discovered	EMS	C	FIXED	Optional
availability	EMS	C	VALUE LIST	NVSList, Optional
linkSRG	EMS	C	FIXED	
additionalInfo	-	-	-	Name/Value list defined by the EMS vendor. Also, extensions are included in additionalInfo

### 2.17.2 Interfaces

**Table Error! No text of specified style in document.-43. MLSNPPLinkMgr**

Operation	Status	Support	Exception/ Error Reason	Comments
getAvailableCapacity	M			
assignSignallingController	O			
deassignSignallingController	O			
setSignallingProtocolAndParameters	O			
setTNANameForMLSNPPLinkEnd	O			
modifySignallingProtocolParameters	O			
enableSignalling	O			
disableSignalling	O			

### 2.17.3 Notifications

There are no specific notifications associated with the data types in this module.



## 2.18 MTNM Version Module

### 2.18.1 Data Types

This module has no data types that represent second level objects.

### 2.18.2 Interfaces

**Table Error! No text of specified style in document.-44.** Version

Operation	Status	Support	Exception/ Error Reason	Comments
getVersion	M			

### 2.18.3 Notifications

There are no specific notifications associated with the data types in this module.

## 2.19 MultiLayerSubnetwork Module

### 2.19.1 Data Types

**Table Error! No text of specified style in document.-45.** MultiLayerSubnetwork

Attribute Name	Set By	Set When and How	Format	Clarification Needed
name	EMS	C	FREE	
userLabel	E	A – set by the EMS (C), or by the NMS via setUserLabel (L)	FREE	As noted in Section 4.3, userLabel, owner, nativeEMSName can be used in a variety of ways. The EMS vendor (SP) should describe their particular usage of these attributes.
nativeEMSName	E	A – set by the EMS (C), or by the NMS via setNativeEMSName (L)	FREE (e.g. CLEI code)	
owner	NMS	L – setOwner	FREE	
subnetworkType	EMS	C	FIXED (e.g., TOPO_SINGLETON)	
supportedRates	EMS	A	VALUE LIST (e.g., LR_Low_Order_TU3_VC3, LR_STS1_and_AU3_High_ Order_VC3, LR_STS3c_and_AU4_VC4)	
additionalInfo	-	-	-	Name/Value list defined by the EMS vendor.  Also, extensions are included in additionalInfo.  For v3.5 the following elements are specified: RoutingAreaLevel, SuperiorMLRA, LayeredRoutingAreaIdList, SupportingMEName, SRGNode
Version 3.0 Additions				
NetworkAccess Domain	E	EMS (C) or NMS via setAdditionalInfo (L)	FREE	

**Table Error! No text of specified style in document.-46. TP Pool Create Data**

Attribute Name	Set By	Set When and How	Format	Clarification Needed
userLabel	NMS	C – createTPPool	FREE	
forceUniqueness	NMS	C – createTPPool	FIXED	
owner	NMS	C – createTPPool	FREE	
containingMLSN	NMS	C – createTPPool	FIXED	
containedMembers	NMS	C – createTPPool	FIXED	
transmissionParams	NMS	C – createTPPool	VALUE LIST	
descriptionOfUse	NMS	C – createTPPool	FREE	
additionalCreationInfo	NMS	C – createTPPool	FREE	

### 2.19.2 Interfaces

The EMS supplier should indicate which of the 4 SNC modes of operation it can support (see Section 4.4 for a description of the SNC modes of operation). The NMS supplier should also indicate which mode(s) it can support.

**Table Error! No text of specified style in document.-47. Multi-layer Subnetwork Manager**

Operation	Status	Support	Exception/ Error Reason	Comments
activateSNC	O			The activateSNC operation is idempotent. The EMS does not send cross connection commands to NE a second time however the commands may be sent for the transmission parameters (the EMS vendor should indicate if this is the case for their EMS).
checkValidSNC	O			

## MTNM IMPLEMENTATION STATEMENT TEMPLATES AND GUIDELINES

createAndActivateSNC	M			For this operation and the other SNC establishment operations, the EMS vendor should indicate whether it is capable of automatically establishing HO SNCs to support a new SNC request, and whether the EMS supports reconfiguration of existing SNC in support of a new SNC request.
createSNC	O			
deactivateAndDeleteSNC	M			
deactivateSNC	O			
deleteSNC	O			
getAllEdgePoints	M			
getAllEdgePointNames	M			
getAllManagedElements	M			
getAllManagedElementNames	M			
getAllSubnetworkConnections	M			
getAllSubnetworkConnectionNames	M			
getAllSubnetworkConnectionsWithTP	M			
getAllSubnetworkConnectionNamesWithTP	M			
getAllTopologicalLinks	O			
getAllTopologicalLinkNames	O			
getAllTPPoolNames	O			
getAllTPPools	O			
getAssociatedTP	O			
getMultiLayerSubnetwork	M			
getRoute	O			
getSNC	O			
getSNCsByUserLabel	O			
getTopologicalLink	O			
getTPGroupingRelationships	O			
Version 3.0 Additions				
addRoute	O			
createModifiedSNC	O			

TM FORUM Implementation Statement (IS) Template and Guidelines

createTPPool	O			
deleteTPPool	O			
getAllFixedSubnetworkConnectionNames	O			
getAllFixedSubnetworkConnectionNamesWithTP	O			
getAllFixedSubnetworkConnections	O			
getAllFixedSubnetworkConnectionsWithTP	O			
getBackupRoutes	O			
getIntendedRoute	O			
getRouteAndTopologicalLinks	O			
getTPPool	O			
modifySNC	O			
modifyTPPool	O			
removeRoute	O			
setIntendedRoute	O			
setRoutesAdminState	O			
swapSNC	O			
switchRoute	O			
Version 3.5 Additions				
getAllSubordinateMLSNs	O			
getAllSubordinateRAidsWithConnection	O			
getMLSNPPLink	O			
getAllMLSNPPLinks	O			
getAllInternalMLSNPPLinks	O			
getAllEdgeMLSNPPLinks	O			
getAllMLSNPPs	O			
getAllCallsAndTopLevelConnections	M			
getAllCallsAndTopLevelConnectionsAndSNCs	O			
getAllCallsAndTopLevelConnectionsWithME	O			
getAllCallsAndTopLevelConnectionsAndSNCsWithME	O			

## MTNM IMPLEMENTATION STATEMENT TEMPLATES AND GUIDELINES

getAllCallsAndTopLevelConnectionsAndSNCsWithTP	O			
getAllCallIdsWithTP	O			
getAllCallIdsWithSNPPOrTNAName	O			
getCallAndTopLevelConnectionsAndSNCs	O			
getCallAndTopLevelConnections	O			
establishCall	O			
modifyCall	O			
releaseCall	O			
getCall	O			
addConnections	O			
removeConnections	O			
getConnectionsAndRouteDetails	O			
modifyDiversityAndCorouting	O			

### 2.19.3 Notifications

To be provided by the organization preparing an interoperability statement

## 2.20 NMS Session Module

### 2.20.1 Data Types

This module has no data types that represent second level objects.

### 2.20.2 Interfaces

**Table** Error! No text of specified style in document.-48. NmsSession

Operation	Status	Support	Exception/ Error Reason	Comments
eventLossCleared	M			These operations are mandatory in the sense that the NMS can not throw any exceptions.
eventLossOccurred	M			
Version 3.0 Additions				
alarmLossOccurred	M			However, what the NMS does when these methods are called is entirely up to the NMS. The NMS could, for example, do nothing when receiving either of these operations.

### 2.20.3 Notifications

There are no specific notifications associated with the data types in this module.

## 2.21 Notifications Module

### 2.21.1 Data Types

This module has no data types that represent second level objects.

### 2.21.2 Interfaces

There are no interfaces other than the EventIterator, which is used to retrieve a large number of events. This iterator is used in conjunction with the getAllActiveAlarms operation in the managedElementManager module, and the getAllEMSActiveAlarms operation in the emsMgr module.

### 2.21.3 Notifications

There are no specific notifications associated with the data types in this module.

## 2.22 Performance Module

### 2.22.1 Data Types

**Table Error! No text of specified style in document.-49. PMData**

Attribute Name	Set By	Set When and How	Format	Clarification Needed
tpName	EMS	C	FIXED	
layerRate	EMS	C	FIXED	
granularity	EMS	C	FIXED	
retrievalTime	EMS	C	FIXED	
pmMeasurementList	EMS	C	-	See PMMeasurement table below

**Table Error! No text of specified style in document.-50. PMMeasurement**

Attribute Name	Set By	Set When and How	Format	Clarification Needed
pmParameterName	EMS	C	VALUE LIST	The EMS vendor (SP) should describe their support (required) list of PM parameters.
pmLocation	EMS	C	FIXED	The EMS vendor (SP) should indicate support (need) for far-end, near-end and/or bi-directional monitoring for each PM parameter.
value	EMS	C	FIXED	
unit	EMS	C	FREE	The EMS vendor (SP) should describe the type of units they use (require) for each type of PM parameter.

MTNM IMPLEMENTATION STATEMENT TEMPLATES AND GUIDELINES

intervalStatus	EMS	C	FIXED	
----------------	-----	---	-------	--

**Table Error! No text of specified style in document.-51. PMThresholdValue**

Attribute Name	Set By	Set When and How	Format	Clarification Needed
pmParameterName	EMS	C	VALUE LIST	The EMS vendor (SP) should indicate the PM parameter for which they support (require) thresholding.
pmLocation	EMS	C	FIXED	
thresholdType	EMS	C	FIXED	For each type of thresholdable PM parameter, the EMS vendor (SP) should indicate the type of TRIGGER supported (required) and whether or not there is an associated CLEAR.
value	EMS	C	FIXED	
unit	EMS	C	FREE	

**Table Error! No text of specified style in document.-52. PMP (v3.0)**

Attribute Name	Set By	Set When and How	Format	Clarification Needed
name	EMS	C	FREE	
userLabel	E	A – set by the EMS (C), or by the NMS via setUserLabel (L)	FREE	As noted in Section 4.3, userLabel, owner, nativeEMSName can be used in a variety of ways. The EMS vendor (SP) should describe their particular usage of these attributes.
nativeEMSName	E	A – set by the EMS (C), or by the NMS via setNativeEMSName (L)	FREE (e.g. CLEI code)	
owner	NMS	L – setOwner	FREE	
pmParameterWith ThresholdsList	EMS	C	VALUE LIST	
monitoringState	E	A – set by the EMS (A), or by the NMS via enablePMDData or disablePMDData (L)	FIXED	
supervisionState	E	A – set by the EMS (A), or by the NMS via enableTCA or disableTCA (L)	FIXED	
additionalInfo	E	A – set by EMS (C), or by the NMS via setAdditionalInfo	FREE	Name/Value list defined by the EMS vendor

## 2.22.2 Interfaces

**Table** Error! No text of specified style in document.-53. PerformanceManagementMgr

Operation	Status	Support	Exception/ Error Reason	Comments
clearPMDData	O			
disablePMDData	M			
disableTCA	O			
enablePMDData	M			
enableTCA	O			
getAllCurrentPMDData	O			
getHistoryPMDData	O			
getHoldingTime	O			
getMEPMCcapabilities	M			
getTCATPPParameter	M			
setTCATPPParameter	O			
Version 3.0 Additions				
createTCAPParameterProfile	O			
deleteTCAPParameterProfile	O			
getAllPMPNames	O			
getAllPMPs	O			
getAllTCAPParameterProfiles	O			
getAllTCAPParameterProfileNames	O			
getProfileAssociatedTPs	O			
getTCAPParameterProfile	O			
getTPHistoryPMDData	O			
setTCAPParameterProfile	O			
setTCAPParameterProfilePointer	O			

There are also PMDataIterator and PMPIterator interfaces that allow for the retrieval of a large number of PM data records, and PMP objects, respectively. The PM specification also allows for the bulk retrieval of PM data via file transfer.

The TCAPParameterProfileIterator allows for the bulk retrieval of TCA parameter profiles.



**2.22.3 Notifications**

To be provided by the organization preparing an interoperability statement

**2.23 Protection Module**

**2.23.1 Data Types**

**Table Error! No text of specified style in document.-54. ProtectionGroup**

Attribute Name	Set By	Set When and How	Format	Clarification Needed
name	EMS	C	FREE	
userLabel	E	A – set by the EMS (C), or by the NMS via setUserLabel (L)	FREE	As noted in Section 4.3, userLabel, owner, nativeEMSName can be used in a variety of ways. The EMS vendor (SP) should describe their particular usage of these attributes.
nativeEMSName	E	A – set by the EMS (C), or by the NMS via setNativeEMSName (L)	FREE (e.g. CLEI code)	
owner	NMS	L – setOwner	FREE	
protectionGroupType	EMS	C	FIXED	
protectionSchemeState	EMS	C	FIXED	
reversionMode	EMS	C	FIXED	
rate	EMS	C	FIXED	
pgpTPList	EMS	A	FIXED	
pgpParameters	EMS	A	FIXED	
additionalInfo	-	-	-	Name/Value list defined by the EMS vendor.  Also, extensions are included in additionalInfo.
Version 3.0 Additions				
ASAPpointer	E	EMS (C), or by the NMS via assignASAP (L)	FIXED	
G.774.3::APSfunction	E	EMS (C) or NMS via setAdditionalInfo (L)	FIXED	

**Table Error! No text of specified style in document.-55. EprotectionGroup (v3.0)**

Attribute Name	Set By	Set When and How	Format	Clarification Needed
name	EMS	C	FREE	

## TM FORUM Implementation Statement (IS) Template and Guidelines

userLabel	E	A – set by the EMS (C), or by the NMS via setUserLabel (L)	FREE	As noted in Section 4.3, userLabel, owner, nativeEMSName can be used in a variety of ways. The EMS vendor (SP) should describe their particular usage of these attributes.
nativeEMSName	E	A – set by the EMS (C), or by the NMS via setNativeEMSName (L)	FREE (e.g. CLEI code)	
owner	NMS	L – setOwner	FREE	
eProtectionGroupType	EMS	C	FIXED	
protectionSchemeState	EMS	C	FIXED	
reversionMode	EMS	C	FIXED	
protectedList	EMS	A	FIXED	
protectingList	EMS	A	FIXED	
ePgpParameters	EMS	A	FIXED	
additionalInfo	-	-	-	Name/Value list defined by the EMS vendor.  Also, extensions are included in additionalInfo.
Version 3.0 Addition				
ASAPpointer	E	EMS (C), or by the NMS via assignASAP (L)	FIXED	
G.774.3::APSfunction	E	EMS (C) or NMS via setAdditionalInfo (L)	FIXED	

### 2.23.2 Interfaces

**Table Error! No text of specified style in document.-56. ProtectionMgr**

Operation	Status	Support	Exception/ Error Reason	Comments
getAlINUTTPNames	O			
getAllPreemptibleTPNames	O			
getAllProtectedTPNames	O			
getAllProtectionGroups	M			
getProtectionGroup	M			
performProtectionCommand	O			
retrieveSwitchData	O			
Version 3.0 Additions				
getAllEProtectionGroups	O			

## MTNM IMPLEMENTATION STATEMENT TEMPLATES AND GUIDELINES

getEProtectionGroup	O			
retrieveESwitchData	O			

Also available are the ProtectionGroupIterator and EProtectionGroupIterator interfaces that allow the NMS to retrieve a large number of protection groups and eprotection groups, respectively (one batch at a time).

### 2.23.3 Notifications

To be provided by the organization preparing an interoperability statement

## 2.24 Session Module

### 2.24.1 Data Types

This module has no data types that represent second level objects.

### 2.24.2 Interfaces

**Table Error! No text of specified style in document.-57. Session**

Operation	Status	Support	Exception/ Error Reason	Comments
endSession	M			
ping	M			
getAssociatedSession	M			This operation is automatically generated by the CORBA language mappings

### 2.24.3 Notifications

There are no specific notifications associated with the data types in this module.

## 2.25 SoftwareAndDataManager Module (v3.0)

### 2.25.1 Data Types

This module has no data types that represent second level objects.

### 2.25.2 Interfaces

**Table Error! No text of specified style in document.-58. SoftwareAndDataManager**

Operation	Status	Support	Exception/ Error Reason	Comments
abortMEBackup	O			
backupME	O			
getBackupList	O			

## TM FORUM Implementation Statement (IS) Template and Guidelines

getMEBackupStatus	O			
-------------------	---	--	--	--

There is also a BackupIdIterator interface that allows the NMS to retrieve a large number of BackupId structs.

### 2.25.3 Notifications

To be provided by the organization preparing an interoperability statement

## 2.26 Subnetwork Connection Module

### 2.26.1 Data Types

**Table Error! No text of specified style in document.-59. Cross Connection**

Attribute Name	Set By	Set When and How	Format	Clarification Needed
active	EMS		FIXED	
aEndNameList	E	C – these attributes are set when the associated SNC is created (i.e., via activateSNC, createSNC or createAndActivateSNC)  If the CC is created outside of the interface, these attributes are set by the EMS.	FIXED	
zEndNameList	E		FIXED	
direction	E		FIXED	
ccType	E		FIXED	
additionalInfo	-	-	-	Name/Value list defined by the EMS vendor.  Also, extensions are included in additionalInfo.
Version 3.0 Additions				
Fixed	EMS	C	FIXED	
RouteActualState	E	A	FIXED	
RouteAdminState	E	EMS (C), or NMS via createAndActivateSNC, createSNC (C), or setAdditionalInfo (L)	FIXED	
RouteExclusive	E	EMS (C), or NMS via createAndActivateSNC, createSNC (C), or setAdditionalInfo (L)	FIXED	
RouteId	E	EMS (C), or NMS via createAndActivateSNC, createSNC (C)	FREE	

MTNM IMPLEMENTATION STATEMENT TEMPLATES AND GUIDELINES

RouteIntended	E	EMS (C), or NMS via createAndActivateSNC, createSNC (C)	FIXED	
RouteInUseBy	E	EMS (C), or NMS via createAndActivateSNC, createSNC (C)	FIXED	
Version 3.5 additions for control plane				
RouteId	EMS	C	FREE	Part of additionalInfo
RouteIntended	EMS	C	FIXED	Part of additionalInfo
RouteActualState	EMS	A	FIXED	Part of additionalInfo
RouteAdminState	EMS	A	FIXED	Part of additionalInfo
RouteInUse	EMS	A	FIXED	Part of additionalInfo
RouteExclusive	EMS	C	FIXED	Part of additionalInfo
Supported CP connection	EMS	C	FREE	Part of additionalInfo
End points	EMS	C	FIXED	Part of additionalInfo
Routing Node information	EMS	C	FREE	Part of additionalInfo

**Table Error! No text of specified style in document.-60. SNCCreateData**

Attribute Name	Set By	Set When and How	Format	Clarification Needed
userLabel	NMS	C – createAndActivateSNC or createSNC	FREE	
forceUniqueness	NMS	C – createAndActivateSNC or createSNC	FIXED	
owner	NMS	C – createAndActivateSNC or createSNC	FREE	
direction	NMS	C – createAndActivateSNC or createSNC	FIXED	
staticProtection Level	NMS	C – createAndActivateSNC or createSNC	FIXED	
protectionEffort	NMS	C – createAndActivateSNC or createSNC	FIXED	
rerouteAllowed	NMS	C – createAndActivateSNC or createSNC	FIXED	

## TM FORUM Implementation Statement (IS) Template and Guidelines

networkRouted	NMS	C – createAndActivateSNC or createSNC	FIXED	
sncType	NMS	C – createAndActivateSNC or createSNC	FIXED	
layerRate	NMS	C – createAndActivateSNC or createSNC	VALUE LIST	
cclInclusions	NMS	C – createAndActivateSNC or createSNC	FIXED	For Control plane connection, this represents the Routing Node connections
neTpInclusions	NMS	C – createAndActivateSNC or createSNC	FIXED	MLRAs/MEs/TLs/MLSNPPLin ks/SNPPList/TPs/SNPs/GTPs /SNCs
fullRoute	NMS	C – createAndActivateSNC or createSNC	FIXED	
neTpSnc Exclusions	NMS	C – createAndActivateSNC or createSNC	FIXED	MLRAs/MEs/TLs/MLSNPPLin ks/SNPPList/TPs/SNPs/GTPs /SNCs
aEnd	NMS	C – createAndActivateSNC or createSNC	FIXED	For Control plane connection, this identifies an SNP or an SNPP. The optional TNA/FTP/CTP values are provided by additional info.
zEnd	NMS	C – createAndActivateSNC or createSNC	FIXED	
additional CreationInfo	NMS	C – createAndActivateSNC or createSNC		Version 3.5 allows adding additional Control plane specific attributes. See the list of these attributes below.
Version 3.0 Additions				
A<n>Role	NMS	C – createAndActivateSNC or createSNC	FIXED	Indicates the end point role of an aEnd TP of an SNC, where <n> refers to the index of the TP within the aEnd list.
AlarmReporting	NMS	C – createAndActivateSNC or createSNC	FIXED	
ASAPpointer	NMS	C – createAndActivateSNC or createSNC	FIXED	
BLSRDirection	NMS	C – createAndActivateSNC or createSNC	FIXED	
BundledSNC Indicator	NMS	C – createAndActivateSNC or createSNC	FIXED	
MustRemoveGTPs	NMS	C – createAndActivateSNC or createSNC	FIXED	

MTNM IMPLEMENTATION STATEMENT TEMPLATES AND GUIDELINES

NetworkAccess Domain	NMS	C – createAndActivateSNC or createSNC	FREE	
NetworkReroute	NMS	C – createAndActivateSNC or createSNC	FIXED	
SNC_INTENDED_ROUTE_EXCLUSIVE	NMS	C – createAndActivateSNC or createSNC	FIXED	
SNC_PRIORITY	NMS	C – createAndActivateSNC or createSNC	FIXED	
SNC_REVERTIVE	NMS	C – createAndActivateSNC or createSNC	FIXED	
Timeslot	NMS	C – createAndActivateSNC or createSNC	FIXED	
Z<n>Role	NMS	C – createAndActivateSNC or createSNC	FIXED	Indicates the end point role of a zEnd TP of an SNC, where <n> refers to the index of the TP within the zEnd list.
Version 3.5 Additions				
ConnectionName	NMS	C – by NMS (C) via establishCall	FIXED	
aEndTPList	NMS	C – by NMS (C) via establishCall	FIXED	
zEndTPList	NMS	C – by NMS (C) via establishCall	FIXED	
tNANameOrGroupT NAName	NMS	C – by NMS (C) via establishCall	FIXED	
tNANameOrGroupT NAName	NMS	C – by NMS (C) via establishCall	FIXED	
maximumCost	NMS	C – by NMS (C) via establishCall	FIXED	
routingConstraintEff ort	NMS	C – by NMS (C) via establishCall	FIXED	
routeGroupLabel	NMS	C – by NMS (C) via establishCall	FIXED	

**Table Error! No text of specified style in document.-61. SNC Modify Data**

TM FORUM Implementation Statement (IS) Template and Guidelines

Attribute Name	Set By	Set When and How	Format	Clarification Needed
userLabel	NMS	C - createModifiedSNC	FREE	
forceUniqueness	NMS	C - createModifiedSNC	FIXED	
owner	NMS	C - createModifiedSNC	FREE	
direction	NMS	C - createModifiedSNC	FIXED	
modify_type	NMS	C - createModifiedSNC	FIXED	
retainOldSNC	NMS	C - createModifiedSNC	FIXED	
modify_servers_allowed	NMS	C - createModifiedSNC	FIXED	
staticProtection Level	NMS	C - createModifiedSNC	FIXED	
protectionEffort	NMS	C - createModifiedSNC	FIXED	
rerouteAllowed	NMS	C - createModifiedSNC	FIXED	
networkRouted	NMS	C - createModifiedSNC	FIXED	
sncType	NMS	C - createModifiedSNC	FIXED	
layerRate	NMS	C - createModifiedSNC	VALUE LIST	
addedOrNewRoute	NMS	C - createModifiedSNC	FIXED	
removedRoute	NMS	C - createModifiedSNC	FIXED	
neTpInclusions	NMS	C - createModifiedSNC	FIXED	
fullRoute	NMS	C - createModifiedSNC	FIXED	
neTpSnc Exclusions	NMS	C - createModifiedSNC	FIXED	
aEnd	NMS	C - createModifiedSNC	FIXED	
zEnd	NMS	C - createModifiedSNC	FIXED	
additionalCreationInfo	NMS	C - createModifiedSNC		
Version 3.0 Additions				
AlarmReporting	NMS	C - createModifiedSNC	FIXED	
ASAPpointer	NMS	C - createModifiedSNC	FIXED	
MustRemoveGTPs	NMS	C - createModifiedSNC	FIXED	
NetworkAccess Domain	NMS	C - createModifiedSNC	FREE	
NetworkReroute	NMS	C - createModifiedSNC	FIXED	
SNC_PRIORITY	NMS	C - createModifiedSNC	FIXED	



MTNM IMPLEMENTATION STATEMENT TEMPLATES AND GUIDELINES

**Table Error! No text of specified style in document.-62. Subnetwork Connection**

Attribute Name	Set By	Set When and How	Format	Clarification Needed
name	E	C – set by the EMS (C) or by the NMS (C) via establishCall	FREE	Version 3.5 allows NMS to set the name
userLabel	E	A – set by the EMS (C), or by the NMS (L) via setUserLabel, createAndActivateSNC, createSNC	FREE	As noted in Section 4.3, userLabel, owner, nativeEMSName can be used in a variety of ways. The EMS vendor (SP) should describe their particular usage of these attributes.
nativeEMSName	E	A – set by the EMS (C), or by the NMS via setNativeEMSName (L)	FREE (e.g. CLEI code)	
owner	NMS	L – setOwner, createAndActivateSNC, createSNC	FREE	
sncState	EMS	A	FIXED	EMS vendor, Service Provider (SP) or NMS vendor should indicate whether or not they support the <i>pending</i> state.  In cases where the <i>pending</i> state is supported, it should indicate whether "Soft reservation with multiple pending" or "Hard Reservation with single pending" is supported.  For Control plane SNC, always fixed to ACTIVE
direction	E	C – any of the SNC establishment operations  If the SNC is created outside of the interface, these attributes are set by the EMS.	FIXED	
rate	E		FIXED	
staticProtectionLevel	E		FIXED NMS requests protection level and EMS may provide a lower level if the Protection Effort is set to "bestEffort" in the SNC request	EMS vendor (SP or NMS vendor) should indicate the protection levels that they support (require). Any dependencies on MEs should be noted.
sncType	E		FIXED	
aEnd	E		FIXED	For control plane SNC, shall identify an SNP or an SNPP. The optional TNA/FTP/CTP values are provided by additional info.
zEnd	E		FIXED	
rerouteAllowed	E		FIXED	
networkRouted	E		FIXED	

TM FORUM Implementation Statement (IS) Template and Guidelines

additionalInfo	E	A – set by EMS (C), or by the NMS via setAdditionalInfo	FREE	Name/Value list defined by the EMS vendor  In version 3.5, it allows additional attributes for Control plane connection to be added via (1) the additionalCreationInfo field of SNCCreateDataList_T in the establishCall operation or (2) the additionalModificationInfo field of CallModifyData_T in the modifyCall operation
<u>route</u>  (The SNC's route is retrieved by getRoute operation and is characterized by the subtending cross connections. The SNC struct does not have a "route" attribute.)	All or part of the route can be specified by the NMS or the NMS can let the EMS design the entire route	C	FIXED	
Version 3.0 Additions				
A<n>Role	E	EMS (C) or set by the NMS using the createAndActivateSNC or createSNC operation	FIXED	Indicates the end point role of an aEnd TP of an SNC, where <n> refers to the index of the TP within the aEnd list.
AlarmReporting	E	EMS (A), or NMS via createAndActivateSNC, createSNC (C), or setAdditionalInfo (L)	FIXED	
ASAPpointer	E	EMS (C), or NMS via createAndActivateSNC, createSNC (C), or assignASAP (L)	FIXED	
BundledSNC Indicator	E	EMS (A), or NMS via createAndActivateSNC, createSNC (C), or setAdditionalInfo (L)	FIXED	
CorrelationID	EMS	L	FREE	
Fixed	EMS	C	FIXED	
MustRemoveGTPs	E	EMS (A), or NMS via createAndActivateSNC, createSNC (C), or setAdditionalInfo (L)	FIXED	
NetworkAccess Domain	E	EMS (A), or NMS via createAndActivateSNC, createSNC (C), or setAdditionalInfo (L)	FREE	

MTNM IMPLEMENTATION STATEMENT TEMPLATES AND GUIDELINES

NetworkReroute	E	EMS (A), or NMS via createAndActivateSNC, createSNC (C), or setAdditionalInfo (L)	FIXED	
SNC_PRIORITY	E	EMS (A), or NMS via createAndActivateSNC, createSNC (C), or setAdditionalInfo (L)	FIXED	
SNC_REVERTIVE	E	EMS (A), or NMS via createAndActivateSNC, createSNC (C), or setAdditionalInfo (L)	FIXED	
Z<n>Role	E	EMS (C) or set by the NMS using the createAndActivateSNC or createSNC operation	FIXED	Indicates the end point role of a zEnd TP of an SNC, where <n> refers to the index of the TP within the zEnd list.
Version 3.5 additions				
connectionSetUpType	EMS	EMS (C)	FIXED	
CallId	EMS	EMS (C)	FIXED	
CallName	EMS	EMS (C)	FIXED	
ConnectionId	EMS	EMS (C)	FIXED	
aEndTPList	EMS	EMS (C)	FIXED	
zEndTPList	EMS	EMS (C)	FIXED	
aEndTNANameList	EMS	EMS (C)	FIXED	
zEndTNANameList	EMS	EMS (C)	FIXED	
connectionState	EMS	EMS (C)	FIXED	
usingHomeRoute	EMS	EMS (C)	FIXED	
routeGroupLabel	EMS	EMS (C)	FIXED	

**Table Error! No text of specified style in document.-63. Route Create Data (v3.0)**

Attribute Name	Set By	Set When and How	Format	Clarification Needed
intended	NMS	C – addRoute	FIXED	
exclusive	NMS	C – addRoute	FIXED	
cclInclusions	NMS	C – addRoute	FIXED	
neTplInclusions	NMS	C – addRoute	FIXED	MLRAs/MEs/TLs/MLSNPPL inks/SNPPList/TPs/SNPs/GTPs

## TM FORUM Implementation Statement (IS) Template and Guidelines

fullRoute	NMS	C – addRoute	FIXED	
neTpSrcExclusions	NMS	C – addRoute	FIXED	MLRAs/MEs/TLs/MLSNPPL inks/SNPPList/TPs/SNPs/G TPs
additionalCreationInfo	NMS	C – addRoute	-	

**Table** Error! No text of specified style in document. **-64.** Route Descriptor (v3.0)

Attribute Name	Set By	Set When and How	Format	Clarification Needed
id	EMS	C- by EMS in response to addRoute	FREE	
intended	EMS	C- by EMS in response to addRoute	FIXED	
actualState	EMS	C- by EMS in response to addRoute	FIXED	
administrativeState	EMS	C- by EMS in response to addRoute	FIXED	
inUseBy	EMS	C- by EMS in response to addRoute	FIXED	
exclusive	EMS	C- by EMS in response to addRoute	FIXED	
routeXCs	EMS	C- by EMS in response to addRoute	FIXED	
additionalInfo	EMS	C- by EMS in response to addRoute	-	

### 2.26.2 Interfaces

There are no interfaces in the subnetwork connection module other than cross connection iterator (i.e., CCIterator) and the SNC iterator (i.e., SNCIterator).

### 2.26.3 Notifications

To be provided by the organization preparing an interoperability statement

## 2.27 Termination Point Module

### 2.27.1 Data Types

MTNM IMPLEMENTATION STATEMENT TEMPLATES AND GUIDELINES

**Table Error! No text of specified style in document.-65. Termination Point**

Attribute Name	Set By	Set When and How	Format	Clarification Needed
name	EMS	C	FREE	The CTP names are fully specified in TMF 814. However, any an example PTP name is given. It is recommended that the EMS supplier state the format used for their PTP names.
userLabel	E	A – set by the EMS (C), or by the NMS via setUserLabel (L)	FREE	As noted in Section 4.3, userLabel, owner, nativeEMSName can be used in a variety of ways. The EMS vendor (SP) should describe their particular usage of these attributes.
nativeEMSName	E	A – set by the EMS (C), or by the NMS via setNativeEMSName (L)	FREE (e.g. CLEI code)	
owner	NMS	L – setOwner	FREE	
ingressTrafficDescriptorName	NMS	A – setTPData (L), or via side effect through activateSNC, deactivateAndDeleteSNC, deactivateSNC (C)	FIXED	The assignment of a Transmission Descriptor (TMD) to a Termination Point (TP) as egress or ingress TMD by using the TMD's name amounts to an overwriting of the layered transmission parameters of the TP by the layered transmission parameters of the TMD, and to an overwriting of the additional info parameters of the TP by the "additional TP information" parameters of the TMD.
egressTrafficDescriptorName	NMS	A – setTPData (L), or via side effect through activateSNC, deactivateAndDeleteSNC, deactivateSNC (C)	FIXED	
type	EMS	C	FIXED	
connectionState	EMS	A	FIXED	
tpMappingMode	E	A – setTPData (L), or via side effect through activateSNC, deactivateAndDeleteSNC, deactivateSNC (C)  Can also be set by the EMS	FIXED	
direction	E	C – via side effect through any of the SNC establishment operations  Can also be set by the EMS	FIXED	

## TM FORUM Implementation Statement (IS) Template and Guidelines

transmissionParams	E	A (depends on the specific transmission parameter) – setTPData (L), or via side effect through activateSNC, deactivateAndDeleteSNC, deactivateSNC (C)	VALUE LIST	EMS vendor (SP or NMS vendor) should indicated supported (required) transmissionParams and associated values
tpProtectionAssociation	EMS	A	FIXED	
edgePoint	EMS	A	FIXED	
additionalInfo	-	-	-	Name/Value list defined by the EMS vendor.  Also, extensions are included in additionalInfo.
Version 3.0 Additions				
ClientConnectivity	EMS	C	FIXED	
ConformanceDefinition	E	EMS (A) or NMS via setAdditionalInfo (L)	VALUE LIST	
ContainedMember	E		FIXED	Used for TP Pools only
DescriptionOfUser	E	EMS (A) or NMS via setAdditionalInfo (L)	FREE	Used for TP Pools only
EgressTMDstate	EMS	A	FIXED	
EquipmentProtected	EMS	A	FIXED	
IngressTMDstate	EMS	A	FIXED	
MemberContainingME<n>	E	EMS (A) or NMS via modifyTPPool	FIXED	Used for TP Pools only
MemberContainingTP<n>	E	EMS (A) or NMS via modifyTPPool	FIXED	Used for TP Pools only
NetworkAccessDomain	E	EMS (C) or NMS via setAdditionalInfo (L)	FREE	
NumberOfMembers	E	EMS (A) or NMS via modifyTPPool	FIXED	Used for TP Pools only
NumberOfIdleMembers	E	EMS (A) or NMS via modifyTPPool	FIXED	Used for TP Pools only
ServerConnectivity	EMS	A	FIXED	
ServiceCategory	E	EMS (C) or NMS via setAdditionalInfo (L)	FIXED	

**Table Error! No text of specified style in document.-66. Group Termination Point (v3.0)**

## MTNM IMPLEMENTATION STATEMENT TEMPLATES AND GUIDELINES

Attribute Name	Set By	Set When and How	Format	
name	EMS	C	FREE	
userLabel	E	A – set by the EMS (C), or by the NMS via setUserLabel (L)	FREE	As noted in Section 4.3, userLabel, owner, nativeEMSName can be used in a variety of ways. The EMS vendor (SP) should describe their particular usage of these attributes.
nativeEMSName	E	A – set by the EMS (C), or by the NMS via setNativeEMSName (L)	FREE (e.g. CLEI code)	
owner	NMS	L – setOwner	FREE	
alarmReportingIndicator	E	A – set by the EMS (C), or by the NMS via or setGtpAlarmReportingOn (L)	FIXED	
listOfTPs	E	A – this attribute can be set at time of creation or modified by either the EMS, or the NMS. The NMS uses the createGTP and modifyGTP operations to set and modify the listOfTPs, respectively.	FIXED	
gtpConnectionState	EMS	A	FIXED	
additionalInfo	-	-	-	Name/Value list defined by the EMS vendor.  Also, extensions are included in additionalInfo.
Version 3.0 Additions				
ASAPpointer	E	EMS (C), or by the NMS via assignASAP (L)	FIXED	
NetworkAccessDomain	E	EMS (C), or NMS via createGTP(C) or setAdditionalInfo (L)	FREE	

### 2.27.2 Interfaces

There are no interfaces in the subnetwork connection module other than Termination Point iterator and the GTP iterator. The TP iterator is used to retrieve a large number of TPs, a batch at a time. The GTP iterator is used to retrieve a large number of GTPs, a batch at a time.

### 2.27.3 Notifications

To be provided by the organization preparing an interoperability statement

## 2.28 Topological Link Module

### 2.28.1 Data Types

**Table Error! No text of specified style in document.-67. Topological Link**

Attribute Name	Set By	Set When and How	Format	Clarification Needed
name	EMS	C	FREE	
userLabel	E	A – set by the EMS (C), or by the NMS via setUserLabel (L)	FREE	As noted in Section 4.3, userLabel, owner, nativeEMSName can be used in a variety of ways. The EMS vendor (SP) should describe their particular usage of these attributes.
nativeEMSName	E	A – set by the EMS (C), or by the NMS via setNativeEMSName (L)	FREE (e.g. CLEI code)	
owner	NMS	L – setOwner	FREE	
direction	EMS	C	FIXED	
rate	EMS	C	FIXED	
aEndTP	EMS	C	FIXED	
zEndTP	EMS	C	FIXED	
additionalInfo	-	-	-	Name/Value list defined by the EMS vendor.  Also, extensions are included in additionalInfo.
Version 3.0 Additions				
AlarmReporting	E	EMS (C) or NMS via setAdditionalInfo (L)	FIXED	
ASAPpointer	E	EMS (C), or by the NMS via assignASAP (L)	FIXED	
AllocatedNumber	E	EMS (C) or NMS via setAdditionalInfo (L)	FIXED	
FragmentServer Layer	E	EMS (C) or NMS via setAdditionalInfo (L)	FIXED	
NetworkAccess Domain	E	EMS (C) or NMS via setAdditionalInfo (L)	FREE	

**Table Error! No text of specified style in document.-68. TL Create Data (v3.0)**

Attribute Name	Set By	Set When and How	Format	Clarification Needed
userLabel	NMS	C - createTopologicalLink	FREE	
forceUniqueness	NMS	C - createTopologicalLink	FIXED	



## MTNM IMPLEMENTATION STATEMENT TEMPLATES AND GUIDELINES

owner	NMS	C - createTopologicalLink	FREE	
direction	NMS	C - createTopologicalLink	FIXED	
rate	NMS	C - createTopologicalLink	FIXED	
aEndTP	NMS	C - createTopologicalLink	FIXED	
zEndTP	NMS	C - createTopologicalLink	FIXED	
additional CreationInfo	NMS	C - createTopologicalLink	FREE	
Version 3.0 Additions				
AlarmReporting	NMS	C - createTopologicalLink	FIXED	
ASAPpointer	NMS	C - createTopologicalLink	FIXED	
NetworkAccess Domain	NMS	C - createTopologicalLink	FREE	

### 2.28.2 Interfaces

There are no interfaces in the subnetwork connection module other than the Topological Link iterator.

### 2.28.3 Notifications

To be provided by the organization preparing an interoperability statement

## 2.29 Traffic Conditioning Profile Module (v3.5)

### 2.29.1 Data Types

**Table Error! No text of specified style in document.-69. TCProfile**

Attribute Name	Set By	Set When and How	Format	Clarification Needed
name	EMS	C	FREE	
userLabel	E	A – set by the EMS (C), or by the NMS via setUserLabel (L) or modifyTransmissionDescript or (L)	FREE	As noted in Section 4.3, userLabel, owner, nativeEMSName can be used in a variety of ways. The EMS vendor (SP) should describe their particular usage of these attributes.
nativeEMSName	E	A – set by the EMS (C), or by the NMS via setNativeEMSName (L)	FREE (e.g. CLEI code)	
owner	NMS	L – setOwner or modifyTransmissionDescript or	FREE	

## TM FORUM Implementation Statement (IS) Template and Guidelines

defaultProfile	EMS	C	FIXED	Defines the TC Profile as a non-deleteable profile (modification may be possible or rejected). An EMS may contain more than one default profile which condition different TPs. Default profiles are created by EMS only.
transmissionParams	NMS	A – set by the NMS when requesting the creation (C) of a Transmission Descriptor, or by modifyTransmissionDescriptor (L)	VALUE LIST	EMS vendor (SP or NMS vendor) should indicated supported (required) transmissionParams and associated values
additionalInfo	-	-	-	Name/Value list defined by the EMS vendor.  Also, extensions are included in additionalInfo.

**Table Error! No text of specified style in document.-70. TCProfile Create Data**

Attribute Name	Set By	Set When and How	Format	Clarification Needed
userLabel	NMS	C – createTransmissionDescriptor	FREE	
forceUniqueness	NMS	C – createTransmissionDescriptor	FIXED	
owner	NMS	C – createTransmissionDescriptor	FREE	
transmissionParams	NMS	C – createTransmissionDescriptor	VALUE LIST	
additionalCreationInfo	NMS	C – createTransmissionDescriptor	FREE	

**Note:** TCProfile Create Data is also used to modify a TC Profile.

There is also the TCProfileIterator interface that allows the NMS to retrieve a large number of Traffic Conditioning Profiles (a batch at a time).

### 2.29.2 Interfaces

**Table Error! No text of specified style in document.-71. TCProfileMgr**

Operation	Status	Support	Exception/ Error Reason	Comments
createTCProfile	O			
deleteTCProfile	O			
getAllTCProfiles	O			
getTCProfileAssociatedTPs	O			

## MTNM IMPLEMENTATION STATEMENT TEMPLATES AND GUIDELINES

getTCPProfile	O			
modifyTCPProfile	O			

### 2.29.3 Notifications

To be provided by the organization preparing an interoperability statement

### 2.30 TrafficDescriptor Module

Traffic Descriptors have been included in release 3 of the NML-EML interface for reasons of backward/forward compatibility. For a release 3 implementation of this interface it is recommended that Traffic Descriptors are not used but instead Transmission Descriptors are used in their place.

#### 2.30.1 Data Types

Traffic descriptors can be created by either the EMS or the NMS. They are presently used in conjunction with ATM. The NMS uses the createTrafficDescriptor operation to create a traffic descriptor.

**Table Error! No text of specified style in document.-72. Traffic Descriptor**

Attribute Name	Set By	Set When and How	Format	Clarification Needed
name	EMS	C	FREE	
userLabel	E	A – set by the EMS (C), or by the NMS via setUserLabel (L)	FREE	As noted in Section 4.3, userLabel, owner, nativeEMSName can be used in a variety of ways. The EMS vendor (SP) should describe their particular usage of these attributes.
nativeEMSName	E	A – set by the EMS (C), or by the NMS via setNativeEMSName (L)	FREE (e.g. CLEI code)	
owner	NMS	L – setOwner	FREE	
serviceCategory	E	C	FIXED	
trafficParameters	E	C	FIXED	
conformanceDefinition	E	C	FIXED	
additionalInfo	-	-	-	Name/Value list defined by the EMS vendor.  Also, extensions are included in additionalInfo.

**Table Error! No text of specified style in document.-73. TD Create Data**

Attribute Name	Set By	Set When and How	Format	Clarification Needed
userLabel	NMS	C – createTraffic Descriptor	FREE	

## TM FORUM Implementation Statement (IS) Template and Guidelines

forceUniqueness	NMS	C – createTraffic Descriptor	FIXED	
owner	NMS	C – createTraffic Descriptor	FREE	
serviceCategory	NMS	C – createTraffic Descriptor	FIXED	
trafficParameters	NMS	C – createTraffic Descriptor	FIXED	
conformance Definition	NMS	C – createTraffic Descriptor	FIXED	
additionalInfo	NMS	C – createTraffic Descriptor	FREE	

### 2.30.2 Interfaces

**Table Error! No text of specified style in document.-74. TrafficDescriptorMgr**

Operation	Status	Support	Exception/ Error Reason	Comments
createTrafficDescriptor	O			
deleteTrafficDescriptor	O			
getAllTrafficDescriptorNames	M			
getAllTrafficDescriptors	M			
getAssociatedCTPs	M			
getTrafficDescriptor	M			

There is also the TrafficDescriptorIterator interface that allows the NMS to retrieve a large number of Traffic Descriptors (a batch at a time).

### 2.30.3 Notifications

To be provided by the organization preparing an interoperability statement

## 2.31 Transmission Descriptor Module (v3.0)

### 2.31.1 Data Types

**Table Error! No text of specified style in document.-75. Transmission Descriptor**

Attribute Name	Set By	Set When and How	Format	Clarification Needed
name	EMS	C	FREE	

MTNM IMPLEMENTATION STATEMENT TEMPLATES AND GUIDELINES

userLabel	E	A – set by the EMS (C), or by the NMS via setUserLabel (L) or modifyTransmissionDescriptor (L)	FREE	As noted in Section 4.3, userLabel, owner, nativeEMSName can be used in a variety of ways. The EMS vendor (SP) should describe their particular usage of these attributes.
nativeEMSName	E	A – set by the EMS (C), or by the NMS via setNativeEMSName (L)	FREE (e.g. CLEI code)	
owner	NMS	L – setOwner or modifyTransmissionDescriptor	FREE	
transmissionParams	NMS	A – set by the NMS when requesting the creation (C) of a Transmission Descriptor, or by modifyTransmissionDescriptor (L)	VALUE LIST	EMS vendor (SP or NMS vendor) should indicated supported (required) transmissionParams and associated values
additionalTPInfo	NMS	A – set by the NMS when requesting the creation of a Transmission Descriptor, or by modifyTransmissionDescriptor (L)	FREE	
<i>ConformanceDefinition (in additionalTPInfo)</i>	E	EMS (C) or NMS via setAdditionalInfo (L)	VALUE LIST	
<i>ServiceCategory (in additionalTPInfo)</i>	E	EMS (C) or NMS via setAdditionalInfo (L)	FIXED	
containingTMDName	NMS	A – set by the NMS when requesting the creation of a Transmission Descriptor (C), or by modifyTransmissionDescriptor (L)	FIXED	
externalRepresentationReference	NMS	A – set by the NMS when requesting the creation of a Transmission Descriptor(C), or by modifyTransmissionDescriptor (L)	FREE	
additionalInfo	-	-	-	Name/Value list defined by the EMS vendor.  Also, extensions are included in additionalInfo.

**Table Error! No text of specified style in document.-76. TMD Create Data**

Attribute Name	Set By	Set When and How	Format	Clarification Needed
userLabel	NMS	C – createTransmissionDescriptor	FREE	
forceUniqueness	NMS	C – createTransmissionDescriptor	FIXED	

## TM FORUM Implementation Statement (IS) Template and Guidelines

owner	NMS	C – createTransmission Descriptor	FREE	
transmissionParams	NMS	C – createTransmission Descriptor	VALUE LIST	
additionalObjectInfo	NMS	C – createTransmission Descriptor	FREE	
containingTMDName	NMS	C – createTransmission Descriptor	FIXED	
externalRepresentation Reference	NMS	C – createTransmission Descriptor	FREE	
additionalCreationInfo	NMS	C – createTransmission Descriptor	FREE	

**Table Error! No text of specified style in document.-77. TMD Modification Data**

Attribute Name	Set By	Set When and How	Format	Clarification Needed
userLabel	NMS	C – createTransmission Descriptor	FREE	
forceUniqueness	NMS	C – createTransmission Descriptor	FIXED	
owner	NMS	C – createTransmission Descriptor	FREE	
transmissionParams	NMS	C – createTransmission Descriptor	VALUE LIST	
additionalObjectInfo	NMS	C – createTransmission Descriptor	FREE	
containingTMDName	NMS	C – createTransmission Descriptor	FIXED	
externalRepresentation Reference	NMS	C – createTransmission Descriptor	FREE	
additionalCreationInfo	NMS	C – createTransmission Descriptor	FREE	

There is also the TransmissionDescriptorIterator interface that allows the NMS to retrieve a large number of Traffic Descriptors (a batch at a time).

### 2.31.2 Interfaces

**Table Error! No text of specified style in document.-78. TransmissionDescriptorMgr**

## MTNM IMPLEMENTATION STATEMENT TEMPLATES AND GUIDELINES

Operation	Status	Support	Exception/ Error Reason	Comments
createTransmissionDescriptor	O			
deleteTransmissionDescriptor	O			
getAllTransmissionDescriptorNames	O			
getAllTransmissionDescriptors	O			
getAssociatedTPs	M			
getTransmissionDescriptor	O			
modifyTransmissionDescriptor	O			Added in version 3.5.
validateTMDAssignmentToObject	O			
setTMDAssociation	O			

### 2.31.3 Notifications

To be provided by the organization preparing an interoperability statement

## 2.32 Transmission Parameters Module

The MTNM transmission parameters are defined in two supporting documents, i.e., *Layered Parameters* and *Layer Rates*.

### 2.32.1 Data Types

This module has no data types that represent second level objects.

### 2.32.2 Interfaces

There are no interfaces associated with the TransmissionParameters module.

### 2.32.3 Notifications

There are no specific notifications associated with the data types in this module.

## 2.33 Miscellaneous

This section covers functional implementation items that do not fit easily in the templates presented earlier in Section 2.

### 2.33.1 Version of CORBA and CORBA Services

The vendor should indicate the version of CORBA and the version of the CORBA services that they are using in their product.

**Table Error! No text of specified style in document.-79. CORBA Version**

	OMG Version	Version of Vendor Product	Comments
CORBA	e.g., CORBA 2.2		
Naming Service	e.g., Version 2.2	e.g., Vendor X Version 5.1 (of OMG Version 2.2 Naming Service)	
Notification Service			Note that a vendor could use an OMG compliant Telecom Log Service to support the MTNM notifications requirements.
Telecom Log Service			

### 2.33.2 Usage of the OMG Notification Service

A number of parameters are associated with the usage of the Notification Service. The supporting document to the MTNM IDL, entitled Notification Service Usage, recommends values for the various Notification Service parameters. Table Error! **No text of specified style in document.-80** is used by the vendor or service provider to indicate any variances from the recommendations in the Notification Service Usage document.

**Table Error! No text of specified style in document.-80. Usage of the Notification Service**

Notification Service Characteristic	Vendor Support (Service Provider Requirement)	Comment
Push or Pull		The MTNM Notification Service usage guidelines stipulate that Push should be used
Number of Notifications Channel		The MTNM Notification Service usage guidelines recommend one channel per EMS
Instances of Notification Service		The MTNM Notification Service usage guidelines recommend one per EMS
EventReliability		The use of Persistency is recommended in both cases
ConnectionReliability		
Usage of Event Priority		The same priority for all events is recommended
Discard Policy		FIFO is recommended in both cases
Delivery Order Policy		
Start Time Supported		The recommended value is "FALSE."
Maximum Batch Size		Batch delivery is not recommended. Thus, the recommended value is "0."
Pacing Interval		The recommended value is "0."
RejectNewEvents		The recommended value is "TRUE."
TimeOut		The recommended value is 30 minutes for NT_TCA and NT_ALARM events, and 24 hours for all other events.



**2.33.3 Proprietary LayerRates**

The EML vendor should publish a list of proprietary layerRates that are used along with their definition. When a layerRate has been subsumed into the standard this list should be augmented with the equivalence and obsolescence statement.

The proprietary layerRate should be used where:

- A transport technology within a product is as yet to be incorporated in the MTNM model
  - This layerRate should be marked as **“being standardized”** in its definition in the conformance statement
  - When the transport technology is incorporated the vendor should identify the equivalence and obsolescence in their conformance statement
- A proprietary transport technology has been used which is necessary to expose over the interface for monitoring and/or configuration purposes
  - This layerRate should be marked as **“proprietary”** in its definition in the conformance statement
- Where an NE only provides partial information on the layerRate, e.g., the NE only indicates that the layerRate is SONET or ATM
  - This layerRate should be marked as **“partial”** in its definition and should (where possible) be related to layerRates that it covers

Where a proprietary layerRate is used it may be necessary to name a TP (CTP or FTP) from that layerRate. In this case a name-string similar in structure to that used for a standardize layerRate (in the layerRate list) should be allocated by the vendor and recorded in the conformance statement. To conform to the specification this name-string will start with “PROP” (e.g. “PROP\_sts\_291c”).

**Table Error! No text of specified style in document.-81. Proprietary LayerRate Table**

<b>Layer Rate Number</b> (integer greater than or equal to 10,000)	<b>Layer Rate Name</b> (the names of all proprietary layer rates start with “PROP”)	<b>Status (either “Being Standardized”, “Proprietary”, “Partial” or “Obsolete”)</b>
10,000	PROP_DSR_OC3072_and_STM1024	Being Standardized
10,001	PROP_STs_291c	Proprietary
10,002	PROP_SONET	Partial
10,003	PROP_STs12c_and_VC4_4c	Obsolete  In v3.0, a layerRate equivalent to PROP_STs12c_and_VC4_4c has been defined, i.e., LR_STs12c_and_VC4_4c. So, PROP_STs12c_and_VC4_4c will no longer be used.

### 2.33.4 SNC Type Transitions Related to the ModifySNC Operation

The following table indicates the EMS support of SNC Type transitions that can be invoked through the modifySNC() operation. Although the EMS can provide support for transitions among all SNC Types, the MTNM interface only defines the transitions between ST\_SIMPLE and ST\_ADD\_DROP\_A or ST\_ADD\_DROP\_Z to be mandatory, when modifySNC() is supported. Note that ST\_ADD\_DROP\_Z bi-directional is new for Phase 3.

The modification of the SNC's Static Protection Level does not impact the SNC type. The EMS may support the modification of an unprotected SNC to being a partially, fully or highly protected SNC while maintaining the same SNC type.

In order to complete the following table, the EMS supplier should do the following:

1. Indicate the supported transitions by placing the word "supported" in the appropriate cells (this should, at least, include the mandatory transitions). The other cells should be blank.
2. For each supported transition, indicate the GOI.
3. For ST\_EXPLICIT to ST\_EXPLICIT or other SNC type to/from ST\_EXPLICIT, the GOI needs to be described for different ST\_EXPLICIT traffic flows (e.g. for ST\_EXPLICIT to ST\_SIMPLE the SNC modification is supported as Hitless whenever only inactive protection legs are removed).

MTNM IMPLEMENTATION STATEMENT TEMPLATES AND GUIDELINES

**Table Error! No text of specified style in document.-82. EMS support for SNC Type Transitions**

New SNC type Previous SNC Type	ST_ SIMPLE	ST_ ADD_DR OP_A	ST_ ADD_DRO P_Z	ST_ INTERCON NECT	ST_ DOUBLE_ INTERCON NECT	ST_ DOUBLE_ ADD_DRO P	ST_ OPEN_ ADD_DRO P	ST_EXPLICIT (Describe connectivity transitions that apply to each GOI category)
ST_ SIMPLE	N/A	Mandatory GOI:	Mandatory GOI:	Optional GOI:	Optional GOI:	Optional GOI:	Optional GOI:	HITLESS: MINOR: MAJOR:
ST_ ADD_DROP_A	Mandatory GOI:	N/A	Optional GOI:	Optional GOI:	Optional GOI:	Optional GOI:	Optional GOI:	HITLESS: MINOR: MAJOR:
ST_ ADD_DROP_Z	Mandatory GOI:	Optional GOI:	N/A	Optional GOI:	Optional GOI:	Optional GOI:	Optional GOI:	HITLESS: MINOR: MAJOR:
ST_ INTERCONNECT	Optional GOI:	Optional GOI:	Optional GOI:	N/A	Optional GOI:	Optional GOI:	Optional GOI:	HITLESS: MINOR: MAJOR:
ST_ DOUBLE_ INTERCONNECT	Optional GOI:	Optional GOI:	Optional GOI:	Optional GOI:	N/A	Optional GOI:	Optional GOI:	HITLESS: MINOR: MAJOR:
ST_ DOUBLE_ ADD_DROP	Optional GOI:	Optional GOI:	Optional GOI:	Optional GOI:	Optional GOI:	N/A		HITLESS: MINOR: MAJOR:
ST_ OPEN_ ADD_DROP	Optional GOI:	Optional GOI:	Optional GOI:	Optional GOI:	Optional GOI:	Optional GOI:	N/A	HITLESS: MINOR: MAJOR:

TM FORUM Implementation Statement (IS) Template and Guidelines

<b>ST_EXPLICIT</b>	HITLESS:	HITLESS:	HITLESS:	HITLESS:	HITLESS:	HITLESS:	HITLESS:	N/A
	MINOR:	MINOR:	MINOR:	MINOR:	MINOR:	MINOR:	MINOR:	
	MAJOR:	MAJOR:	MAJOR:	MAJOR:	MAJOR:	MAJOR:	MAJOR:	

## 3 Non-Functional Interoperability Statements (NIS)

This section covers interoperability issues related to the non-functional aspects of the MTNM interface.

### 3.1 Iterator Implementation Issues

The EMS vendor should state how many iterators can be open at any one point in time. The MTNM team has agreed that 10 is a reasonable number. Any timer behavior associated with an iterator should be stated, e.g., the EMS automatically deletes an iterator if it has not been used in the last 5 minutes.

The EMS may have trouble fulfilling a getLength request when the data is scattered across a number of systems and its volume is not readily measurable and/or where the volume of data available for transfer may change after the request and during the iteration process. Under these circumstances it is acceptable for the EMS to throw a CAPACITY\_EXCEEDED exception. In order to assist the NMS, the EMS vendor shall state clearly in which cases the getLength operation may throw the CAPACITY\_EXCEEDED exception.

### 3.2 Timing Issues

None of the MTNM documents address timing. An EMS and NMS could follow all the MTNM standards as well as an agreed to interoperability statement (such as the one suggested in Section 2 of this document) and still fail to interoperate because of timing issues.

For example, if the NMS uses a large value of how\_many in the next\_n operation, the EMS may take too long to prepare the result, leading to a CORBA message timeout. So, the NMS and EMS need to agree on a reasonable range of values for how\_many. Another example of a potential timeout would be SNC establishment.

In general, the maximum time an NMS is designed to wait for a response to a particular type operation request should be greater than expected maximum time the EMS takes to fulfill the operation request. It is suggested that the EMS vendor provide the following table as guidance:

**Table Error! No text of specified style in document.-83. Operations Response Times and Timeouts**

Operation Type	Maximum Expected EMS Response Time	Suggested Timeout Setting for NMS	Comments
Iterators (if various iterators have different characteristics, then multiple entries in this table are needed)			A Maximum Value for how_many should be provided
Data Retrieval of a Data Structure for a Second-Level Object			
Other operations can be listed on a case-by-case basis (createAndActivate), or groups of operations that			

## TM FORUM Implementation Statement (IS) Template and Guidelines

have similar response time characteristics can be grouped into a single entry in this table (the group of SNC establishment operations)			
---	--	--	--

A similar table is needed for each notification type. There may be delays in delivering a notification. Once a notification has reached a particular age without being delivered to the NMS, it may make no sense for the Notification service to deliver the notification. The parties representing the NMS and EMS need to agree on a timeout period for each notification type.

The following table is needed to specify the heartbeat time constraints for the session supervision from NMS to EMS, and vice versa. It should be noted that Table **Error! No text of specified style in document.-84** refers to pings that are sent from the NMS to the EMS and vice versa, in order to make sure the connection between the NMS and EMS is still up. Table **Error! No text of specified style in document.-85**, on the other hand, refers to NT\_HEARTBEAT notifications sent from the notification service to the NMS (this allows the NMS to know that its connection to the notification service is up).

**Table Error! No text of specified style in document.-84** Heartbeat Time Constraints

Supervising Partner	Time in seconds between two Heartbeat Messages	Number of consecutively failed Heartbeats after which the session is closed	Comments
NMS			The NMS may use requests/responses for supervision instead of heartbeats.
EMS			

In Version 3.0, the EMS may send heartbeat notifications (NT\_HEARTBEAT) when it has not sent any notifications for a period of time. The EMS supplier should indicate how often heartbeat notifications are sent (in the absence of other notifications). The EMS supplier should also indicate the number of consecutively missed heartbeat notifications after which the NMS should consider its association with the notification service has been lost.

**Table Error! No text of specified style in document.-85.** Heartbeat Notification Time Constraints

Time in seconds between two heartbeat notifications	Number of consecutively missed heartbeat notifications after which the NMS should consider its association with the notification service has been lost	Comments

## 4 Guidelines

This section covers guidelines concerning usage of the MTNM specifications. The intent is to describe, in further detail, the more complicated and/or less constrained aspects of the MTNM specifications. For example, the MTNM specifications state that subnetwork configuration is the responsibility of the EMS. Without further information, the NMS vendor needs to design their NMS to anticipate any of a number of possible subnetwork configuration schemes employed by various EMS vendors.

### 4.1 Implementation-specific Use Cases

The MTNM Business Agreement document provides use cases for many management activities, e.g., *NMS Provisions Alarm Monitoring Off*, *The NMS Creates a Subnetwork Connection*, and *Retrieval of Protection Group by the NMS*. These use cases are not prescriptive and allow for many options. For a particular implementation of the NMS-EMS interface, it is recommended that the use cases be specialized and detailed in order to ensure greater interoperability between the NMS and EMS. The use cases in the MTNM BA could serve as a basis for any product-specific use cases.

### 4.2 EMS Subnetwork Configuration

In the MTNM model, the EMS decides how to package MEs into subnetworks. An understanding of how an EMS packages MEs into subnetwork will facilitate inventory discovery on the part of an NMS. Some examples concerning the packaging of the MEs within rings are as follows:

- The EMS packages each ring (SONET, SDH, or DWDM) into a separate subnetwork. Open rings are packaged into separate subnetworks.
  - In this case, the NMS will need to configure ring interconnection.
- The EMS packages interconnected rings (having protected interconnection) into separate subnetworks (this could lead large mesh subnetworks), and all other rings into individual subnetworks. Open rings are packaged into separate subnetworks.
  - In this case, the EMS (or the EMS GUI users) handles most of the configuration concerning ring interconnection.

In the first case above, each ring (or open ring) is in a separate subnetwork. For example, consider the case where a DSC is used to interconnect rings (say ring 1 and ring 2). The DSC is managed by one EMS and the rest of each ring is managed by another EMS. In this case, the NMS needs to setup three SNCs to get an end-to-end connection between a CTP in ring 1 and a CTP in ring 2. The SNCs in ring 1 and 2 would be of type ST\_SIMPLE and the SNC in the DSC would be of type ST\_DOUBLE\_INTERCONNECT.

In the second case, the NMS only needs to request one SNC. In this case, the SNC type would be ST\_DOUBLE\_INTERCONNECT. This case is easier for the NMS since it does not need to know much about the internal structure of the mesh subnetwork (only needs to know that the mesh support DRI).

In the event subnetwork configuration is done via the EMS GUI, the EMS vendor may simply provide guidelines, suggestions and constraints concerning the configuration of subnetworks. In the event subnetwork configuration is performed via fixed logic in the EMS, the EMS vendor would an explanation of how the EMS decides on subnetwork packaging.

### 4.3 Usage of the Various Resource Names

The MTNM interface allows several identifiers to be assigned to a managed resource, i.e., name, userLabel, and nativeEMSName.

- The **name** is assigned by the EMS and it is the unique identifier of resource to be used across the NMS-EMS interface. The NMS has no control over a resource's name.
- The **userLabel** is typically assigned by the NMS via the setUserLabel operation or a create operation for resources that can be created by an NMS request, e.g., SNCs. If a resource is created by the EMS (actually the interface object representing a resource), then the EMS sets the userLabel to the nativeEMSName.
  - Further, the createSNC, createAndActivateSNC, checkValidSNC, and setUserLabel operations accept a parameter that allows the NMS to request that the EMS check the supplied userLabel for uniqueness. If the supplied userLabel is not unique, the request is rejected.
- The **nativeEMSName** was originally intended to be the name of a resource as shown on an EMS display. This usage is not mandatory and other uses are possible. The nativeEMSName can be set by the EMS (typically through the EMS GUI) or it can be set by the NMS (if allowed by the EMS vendor) using the setNativeEMSName operation.

As an example use of the three resource names, consider the end-to-end connection shown in Figure Error! **No text of specified style in document.-1** (as represented by the solid horizontal line). In this example, SNC AbcInc\_3837 crosses three subnetworks, two of which are in one EMS domain (i.e., Subnetworks A and B are in EMS Domain 1) and the other subnetwork (i.e., C) is in another EMS domain (i.e., Domain 2). The EMS uses the Name attribute to uniquely identify an SNC within its domain (this is always true for EMSs that follow the MTNM interface specifications). The network provider uses the NativeEMSName to store its identifier for an SNC. The NativeEMSName can be assigned via the EMS GUI or through the setNativeEMSName operations. The service provider uses the userLabel to associate the three SNCs that comprise the end-to-end connection. In this case, the NMS does not want to force uniqueness of the userLabel. Of course, the NMS could use its own internal mechanism to associate connections that cross several subnetworks. The advantages of using the userLabel in this case are as follows:

- If the NMS fails, the EMS user can still determine the association among related SNCs in different subnetworks (the EMS GUI would need to have appropriate search functions). If the connection crosses multiple EMS domains, correlation becomes more complicated and is likely to require more analysis on the part of the EMS user.
- If the NMS fails, the EMS GUI could be used to create connections crossing multiple subnetworks. After it has recovered, the NMS could discover the SNC associations by looking at the userLabels of the newly created SNCs.



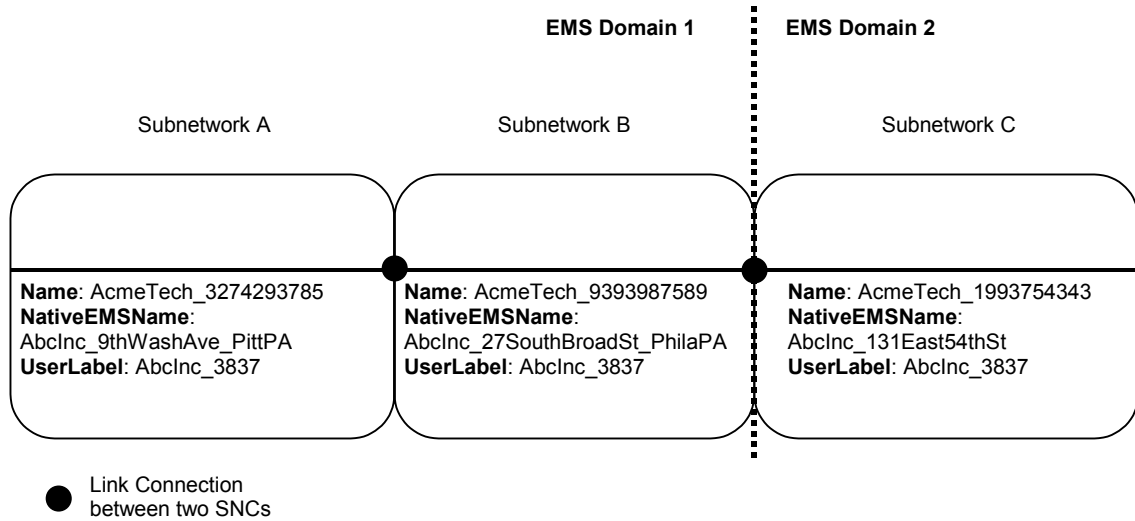

**Figure Error! No text of specified style in document.-1.** SNC Naming Example 1: Non-unique UserLabels

As a second example, consider the end-to-end connection shown in Figure Error! **No text of specified style in document.-2**. The end-to-end connection and component SNCs are the same as in the previous example, only the naming scheme is different. In this approach, the service provider wants the EMS to ensure that unique userLabels are used for each SNC within an EMS’s management domain. If the NMS attempts to setup an SNC using a userLabel that has already been assigned, the EMS will reject the request. This prevents the mistaken re-use of the SNC names selected by the service provider (this could happen during manual entry of SNC names via the NMS GUI, for example). Related SNCs can still be associated. However, in this case, the NativeEMSName is used to associate related SNCs.

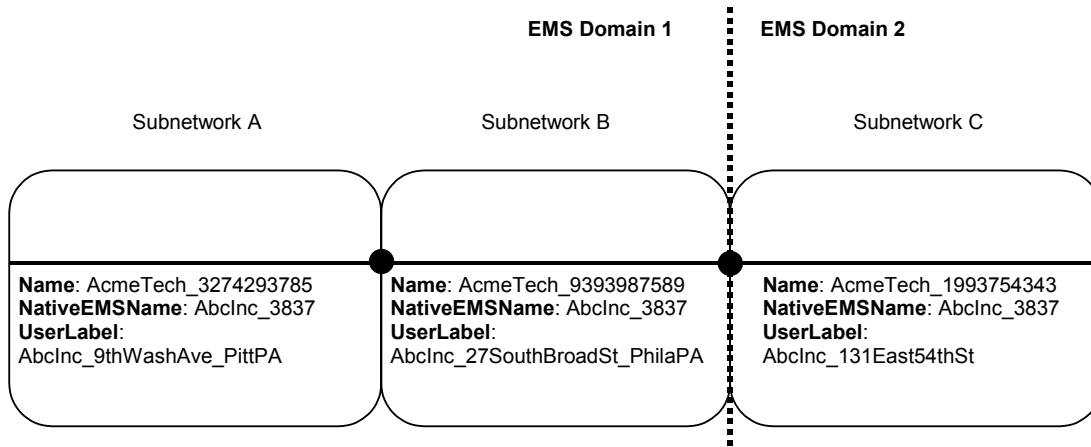

**Figure Error! No text of specified style in document.-2.** SNC Naming Example 2: Unique UserLabels

In another approach, each EMS domain consists of a single subnetwork. The userLabel and nativeEMSName of an SNC are same. Further, the component SNCs of an end-to-end connection have the same userLabel and nativeEMSName, as shown in Figure Error! **No text of specified style in document.-3**. This example has the same advantages as Example 1 and also allows the NMS to request userLabel uniqueness from the EMS as in Example 2. The main disadvantage is that the EMS domain cannot be subdivided into multiple subnetworks.

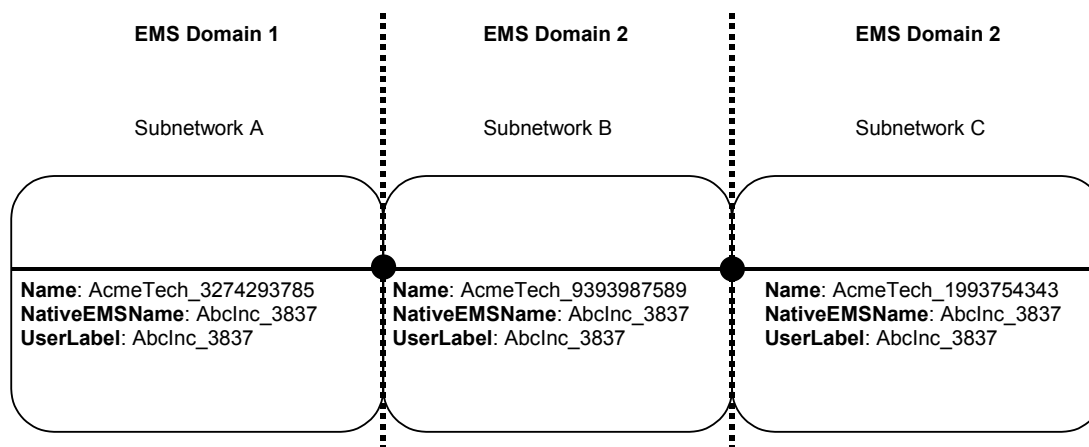

**Figure Error! No text of specified style in document.-3.** SNC Naming Example 3: Same name for userLabel and nativeEMSName

#### 4.4 SNC State Representations – Modes

The member companies comprising the MTNM team have varying opinions concerning the SNC state model, and agreement could not be reached on a single state representation model. Consequently, it was agreed to allow four different SNC state modes:

**Table Error! No text of specified style in document.-86.** SNC State Representation Modes

Mode	Support for Pending state, and allow SNC conflicts on creation, i.e., shared Cross Connections (CCs)	Allow for sharing of Active CCs
A		
B	✓	
C		✓
D	✓	✓

The various modes in the above table are explained in the following subsections.

##### 4.4.1 Mode A

In Mode A, the goal is for the EMS to represent only the current network configuration, to limit as much as possible sharing of resources (i.e., cross connections) among SNCs, and to attempt to have a one-to-one correspondence between the network configurations and the SNC configurations. This mode does not support the pending state. An SNC that does not have any non-shared, active CCs in the network is considered non-existent. Consequently, when the last non-shared cross-connect of an SNC is deactivated in the network, the SNC is deleted by the EMS.

In Mode A, a CC, active or not, can only belong to at most one SNC. In the case of non-singleton subnetworks, an exception to the non-sharing rule is made for SNCs of a broadcast system, i.e., a multipoint connection. The legs of a multipoint connection are represented as individual SNCs. The legs of a broadcast system may share CCs and always share the same source CTP.

Mode A is best for EMSs that only support singleton subnetworks (i.e., subnetwork consisting of a single managed element) and that do not keep a database of pending SNCs. Mode A might be popular with vendors having lightweight switch-bound EMSs.

#### 4.4.2 Mode B

In Mode B, the goal is for the EMS to represent the current network configuration as well as potential “future” SNCs that have been prepared by the NMS, but not yet activated. The Pending state can also be used in situations where SNC share CCs at different times. For example, SNC1 is used by customer A from 8am to 8pm every day. SNC2 shares many CCs with SNC1 but is only used by Customer B from 9pm to 7am every day. When SNC1 is in the Active state, SNC2 is put in the Pending state, and vice versa.

An SNC’s entry and exit to and from the Pending state is controlled solely by the NMS. Neither the EMS or craft intervention can put an SNC into (or remove an SNC from) the Pending state.

#### 4.4.3 Mode C

In Mode C, the goal is for the EMS to represent only the current network configuration (as was the case with Mode A). Contrary to Mode A, it does not limit sharing of CCs among SNCs, and does not attempt to have a one-to-one correspondence between the network configurations and the SNC configurations.

Mode C is best for EMSs that support non-singleton subnetworks and that do not keep a database of pending SNCs. This mode has an advantage over Mode A, because it allows SNC reorganizations without traffic interruption (only useful in non-singleton subnetworks). For example, if the EMS currently has two “consecutive” SNCs that the NMS wants to merge into one “larger” SNC, this can be done without interrupting traffic by creating and activating the larger SNC, then deactivating and deleting the two consecutive SNCs.

#### 4.4.4 Mode D

Mode D is basically a combination of Modes B and C. This Mode is favored by vendors (or service providers) that have a feature rich NMS that can take advantage of the Pending state (related to scheduling features) and the sharing of Active CCs.

### 4.5 Example Probable Cause Template

The following example illustrates the use of the probable cause template defined in Section 2.1.6.1. The example is based on actual SDH and WDM equipment that are managed according to ITU principles. The "Transmission" alarms (from TPs) are from a submarine equipment type that uses Forward Error Correction, or FEC: a method based on Reed-Solomon encoding that enables errors to be not only detected, but corrected.

The following conventions are used in Table Error! **No text of specified style in document.-87.**

#### Identifiers

The “official” MTNM identifiers are used, such as “OT\_PHYSICAL\_TERMINATION\_POINT” instead of abbreviations, e.g., “PTP”. The latter would make for a more legible table of course, but a set of abbreviations is not currently available. The worst problem is with the layer rates: if one just gives the value (e.g., "22") it will not be understood. Unfortunately, the complete strings are fairly long, e.g., "22 = LR\_Section\_OC48\_STS48\_and\_RS\_STM16".

#### Different kinds of Probable Causes:

## TM FORUM Implementation Statement (IS) Template and Guidelines

The example shows the kind of relationships that can exist between (MTNM) Probable Cause, Native Probable Cause, and Probable Cause Qualifier:

- One (MTNM) Probable Cause value may correspond to several Native Probable Cause values
- One Native Probable Cause Value may correspond to several Probable Cause Qualifier values - or to none at all.

### Additional Text:

The strings shown in Probable Cause Qualifier (which is not displayed to NMS operator) can also be used as Additional Text (which is displayed). This is not a general rule, but it is allowed by the MTNM model. The example itself does not include Additional Text.

### Additional Info and ITU alarm coding:

The X.733 Event Type is used as an example of Additional Info.

- The rules for doing this are set out in the "Notification Service Usage" supporting document to the IDL.
- Note that this is optional both for EMS to produce and for NMS to take into account. This only makes sense if both EMS and NMS actually use X.733 alarm format internally.
- The table gives examples of the four X.733 Event Type values applicable for MTNM Alarms (Communications Alarm, Equipment Alarm, Environmental Alarm and Processing Error Alarm). The last Event Type value is Quality Of Service Alarm, which is the same thing in practice as a TCA, even if they are defined differently.

One difference between MTNM and ITU alarm management principles is in "software" or "processing error" faults:

- ITU "Processing Error Alarm" Event Type corresponds to software problems in general, wherever they occur.
- The assumption here is "software" type problems in NEs are given a (MTNM) Probable Cause value "EQPT". Such problems can occur, since NEs perform information processing. However, the same kind of error in the EMS is given a (MTNM) Probable Cause value "EMS".

**Table Error! No text of specified style in document.-87 Example Probable Cause Template**

Probable Cause	Native Probable Cause	Associated Object Type	Layer Rates	Probable Cause Qualifiers	Perceived Severity	Service Affecting	Additional Information (name)	Additional Information (value)
BER_SD	Degraded Signal	OT_PHYSICAL_TERMINATION_POINT	76 = LR_DSR_OC48_and_S TM16	B1 LER detected	PS_MINOR	SA_NON_SERVICE_AFFECTING	"X.721::Event Type"	"communicationsAlarm"
BER_SD	Degraded Signal	OT_CONNECTION_TERMINATION_POINT	76 = LR_DSR_OC48_and_S TM16	FEC error low alarms (LBER)	PS_MINOR	SA_NON_SERVICE_AFFECTING	"X.721::Event Type"	"communicationsAlarm"

## MTNM IMPLEMENTATION STATEMENT TEMPLATES AND GUIDELINES

BER_SD	Fec Uncorrected Blocks	OT_CONNECTI ON_TERMINATI ON_POINT	76 = LR_DSR_O C48_and_S TM16	FEC Uncorrected Blocks	PS_MINOR	SA_NON_SE RVICE_AFFE CTING	"X.721::Even tType"	"communicati onsAlarm"
BER_SD	Optical Signal Degraded	OT_CONNECTI ON_TERMINATI ON_POINT	40 = LR_Optical_ Channel	Optical Signal Degraded	PS_MINOR	SA_NON_SE RVICE_AFFE CTING	"X.721::Even tType"	"communicati onsAlarm"
EQPT	Replaceable Unit Missing	OT_EQUIPMEN T	1 = LR_Not_App licable	Replaceable Unit Missing	PS_MAJOR	SA_SERVIC E_AFFECTIN G	"X.721::Even tType"	"equipmentAl arm"
EQPT	Replaceable Unit Type Mismatch	OT_EQUIPMEN T	1 = LR_Not_App licable	Replaceable Unit Type Mismatch	PS_MAJOR	SA_SERVIC E_AFFECTIN G	"X.721::Even tType"	"equipmentAl arm"
EQPT	Internal Communication Problem	OT_EQUIPMEN T	1 = LR_Not_App licable	Internal Communication Problem	PS_MAJOR	SA_SERVIC E_AFFECTIN G	"X.721::Even tType"	"equipmentAl arm"
EQPT	Unit Failed	OT_EQUIPMEN T	1 = LR_Not_App licable	unitFail	PS_MAJOR	SA_SERVIC E_AFFECTIN G	"X.721::Even tType"	"equipmentAl arm"
EQPT	Unit Failed	OT_EQUIPMEN T	1 = LR_Not_App licable	converterFail	PS_MAJOR	SA_SERVIC E_AFFECTIN G	"X.721::Even tType"	"equipmentAl arm"
EQPT	Unit Failed	OT_EQUIPMEN T	1 = LR_Not_App licable	overCurrent	PS_MAJOR	SA_SERVIC E_AFFECTIN G	"X.721::Even tType"	"equipmentAl arm"
ENV	Air Conditioning Failure	OT_MANAGED_ ELEMENT	1 = LR_Not_App licable		PS_MINOR	SA_NON_SE RVICE_AFFE CTING	"X.721::Even tType"	"environment alAlarm"
EMS	Database Inconsistency	OT_EMS	1 = LR_Not_App licable		PS_WARNI NG	SA_NON_SE RVICE_AFFE CTING	"X.721::Even tType"	"processingEr rorAlarm"
EQPT	Reinitialized	OT_MANAGED_ ELEMENT	1 = LR_Not_App licable		PS_WARNI NG	SA_NON_SE RVICE_AFFE CTING	"X.721::Even tType"	"processingEr rorAlarm"

### 4.6 Mapping of MTNM Services States to Other Models

The Telcordia state model in GR-1093-CORE and the ITU-T state model defined in ITU-T Recommendation X.731 are commonly used in network management interfaces. The MTNM team has defined a state that is different from both the Telcordia and ITU-T model. Mappings between the MTNM state model, and the Telcordia and ITU-T state models are provided in the following two subsections.

#### 4.6.1 Mapping to Telcordia State Model (GR-1093-CORE)

**Table Error! No text of specified style in document.-88 MTNM to Telcordia State Model Mapping**

Telcordia State	MTNM State
IS-NR (In service-normal)	IN_SERVICE
IS-ANR (In service-abnormal)	
IS-RST (In service-restricted)	
IS-ANRST (In service-abnormal & restricted)	
OOS-AU (Out of Service-autonomous - meaning failed, equivalent of disabled)	OUT_OF-SERVICE

## TM FORUM Implementation Statement (IS) Template and Guidelines

OOS-MA (Out of Service-management - meaning administratively placed OOS, equivalent of locked)	OUT_OF_SERVICE_BY_MAINTENANCE
OOS-AUMA (Out of Service-autonomous & management)	OUT_OF_SERVICE_BY_MAINTENANCE
OOS-AURST (Out of Service-autonomous & restricted)	OUT_OF-SERVICE
OOS-MAANR (Out of Service-management & abnormal)	OUT_OF_SERVICE_BY_MAINTENANCE

#### 4.6.2 Mapping to ITU-T States

**Table Error! No text of specified style in document.-89 ITU-T to MTNM State Mapping**

ITU Operational State	ITU Administrative State	MTNM Service State
enabled	unlocked	IN_SERVICE
	locked	OUT_OF_SERVICE_BY_MAINTENANCE
	shutting down	SERV_NA
disabled	unlocked	OUT_OF_SERVICE
	locked	OUT_OF_SERVICE_BY_MAINTENANCE

#### 4.7 Usage of Network Access Domains (NADs)

A given NAD represents a domain to which a set of transmission network resources (e.g., PTPs, CTPs, SNCs) can be assigned and a given Functional Access Domain (FAD) or set of FADs). The FAD or FADs determines the functions which can be applied to the NAD. A network resource can be assigned to only one NAD, or be unassigned (or free). In terms of the MTNM interface, the NMS may assign a NAD to a set of resources. The assignment of the FADs is outside the scope of the interface. This section provides an explanation of how the NAD/FAD concept can be used.

The network administrator can

- a) assign network resources to NADs (i.e. specify owners of various resources). This is done over the NMS-EMS interface by setting the NAD parameter (a v3.0 parameter within additionalInfo) for a set of resources, e.g., TPs and SNCs.
- b) assign users (i.e., operators at NMS and EMS user interface) functional profiles (FAD) thereby allowing the users to perform specific functions on designated resources (as determined by the NAD previously assigned to the resource). One or more FADs can be associated to a given NAD. Thus according to type of user, different types of operations are permitted on the specific NAD. Again, management of the FADs is outside the scope of the MTNM interface.

A given resource with its NetworkAccessDomain parameter set to the empty string is intended to be a “free” resource, i.e., any users can request only MTNM operation on the resource. A given FAD can be defined to permit or refuse access to “free” resources.

Example use of NADs and FADs:

- some resources are marked for the NetworkAccessDomain = "owner23"
- user44 is defined by the network administrator at the EMS to be associated with FAD = "readonly" and to be given access to the "owner23" NAD. So, on the EMS side, "user44" is granted readonly access to the TPs and SNCs belonging to NAD = "owner23".

As another example, it is noted that the NAD/FAD mechanism can be used to define VPNs. In fact, a given VPN could be seen as NAD, where the VPN operator can create/activate, and deactivate/delete SNCs using only the routing resources belonging to such NAD/VPN (e.g., the NMS could include the NAD identifier in the additionalCreationInfo parameter of the createAndActivateSNC operation). At the EMS level, an SNC can be

routed only on resources (CTPs) which NetworkAccessDomain value is equal to such NAD/VPN (or is "free", if the FAD allows it).

## 4.8 Root Cause Alarm Indication

The Root Cause Alarm Indication (RCAI) feature allows the EMS to indicate a distinction between raw (i.e., uncorrelated) alarms, and root cause alarm indications.

The NMS can use the filtering capability of the Notification Service in conjunction with the RCAI field to

- receive only raw alarms, i.e., alarms with the root cause alarm field set to FALSE,
- receive only RCAIs, i.e., alarms with the root cause alarm field set to TRUE, or
- receive both raw alarms and RCAIs.

The following suggestions are noted concerning usage of the RCAI:

1. If a single alarm persists but does not get correlated with any other alarm, two notifications are expected (the raw alarm and the RCAI associated with the uncorrelated raw alarm).
2. There is no field in the RCAI or the raw alarms that points to the other correlated alarms. The idea is to keep the interface as simple as possible and still allow for the reporting of RCAIs.
3. The raw alarms result in notifications immediately. The RCAI is generated after the correlation window closes (the length of the correlation window is an implementation issue for the EMS/NE vendor).
4. RCAIs usually clear after all related raw alarms clear and stay cleared for a persistence interval.

The above points are just suggestions concerning how the RCAI feature could work. Since these suggestions relate to EMS implementation, they are not included in the requirements of the Business Agreement document.

ITU-T Recommendation M.2140, Transport Network Event Correlation, provides additional detail concerning how RCAI might be supported.

Some common questions and answers concerning the proposed model:

Doesn't a notification need to be sent when a raw alarm latter gets declared as a root cause?

In the proposed model, raw alarms do not "change" to root causes. If the root cause of several alarms is identified to be the same as a previous raw alarm, a new root cause alarm indication could be sent to the NMS. Both the original raw alarm and the root cause would be treated as separate alarms in terms of notifications sent over the EMS-NMS interface. Each would be cleared separately.

What notification is sent when a previously declared root cause is now related to another root cause?

If the EMS decides that it has found a better root cause, the EMS could clear the original root cause and declare a new root cause.

## 4.9 FTP Examples

In order to represent managed element with several layers of flexibility, the MTNM team has added support for Floating TPs in v3.0.

An example managed element with several layers of flexibility is shown in Figure **Error! No text of specified style in document.-4** and Figure **Error! No text of specified style in document.-5**. (Figure **Error! No text of specified style in document.-4** is the usual "elevation" figure where layers are shown stacked vertically one above the other - server layers are always beneath client layers. Figure **Error! No text of specified style in document.-5** is a "plane" figure where the layout is "horizontal", as if all the lines in Figure **Error! No text of specified style in document.-4** were twisted to make them parallel. This allows multiplexing to be shown, and is easier to relate to hardware. [Note that Figure **Error! No text of specified style in document.-5** shows four



## MTNM IMPLEMENTATION STATEMENT TEMPLATES AND GUIDELINES

VC4 ports whereas Figure **Error! No text of specified style in document.-4** shows only VC4 port.] The figures use the graphical conventions of ITU-T documents such as G.805. Figure **Error! No text of specified style in document.-4** shows, from right to left:

- An SDH port (layers are modeled according to TMF MTNM, to facilitate comparison with the following figures. These layers are: Physical, Optical Section, Digital Signal Rate, Regeneration Section, Multiplex Section);
- A High Order Matrix with a flexible cross-connection at AU4 / VC4 (SONET: STS3c) level;
- The VC4 TTP, comprising termination function and adaptation function, with mapping to 3 TU3's;
- A Low Order Matrix with a flexible cross-connection at TU3 / VC3 (SONET: STS1) level;
- A fixed connection at 45Mbit (DS3) tributary level;
- A PDH port (with layers: Phy, DSR, 45M).

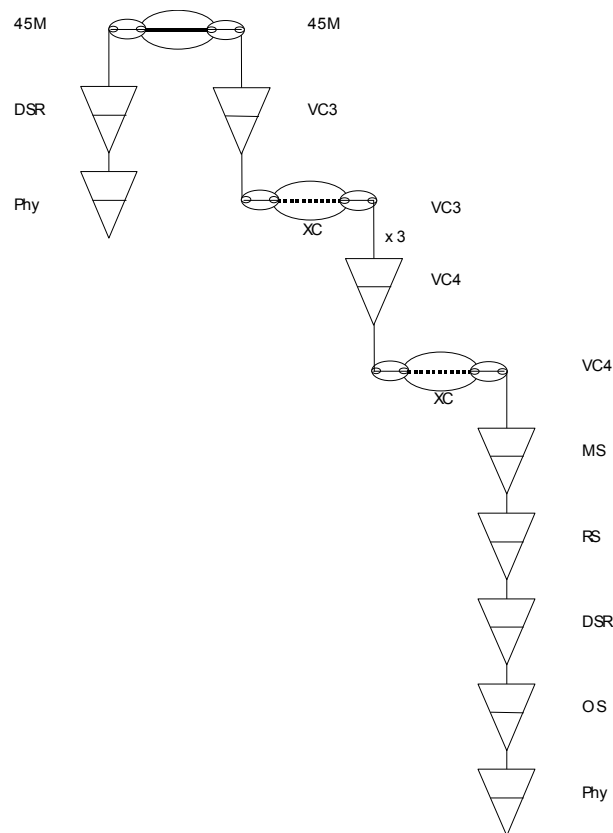

**Figure Error! No text of specified style in document.-4.** G. 805 modeling example ("elevation" view)

TM FORUM Implementation Statement (IS) Template and Guidelines

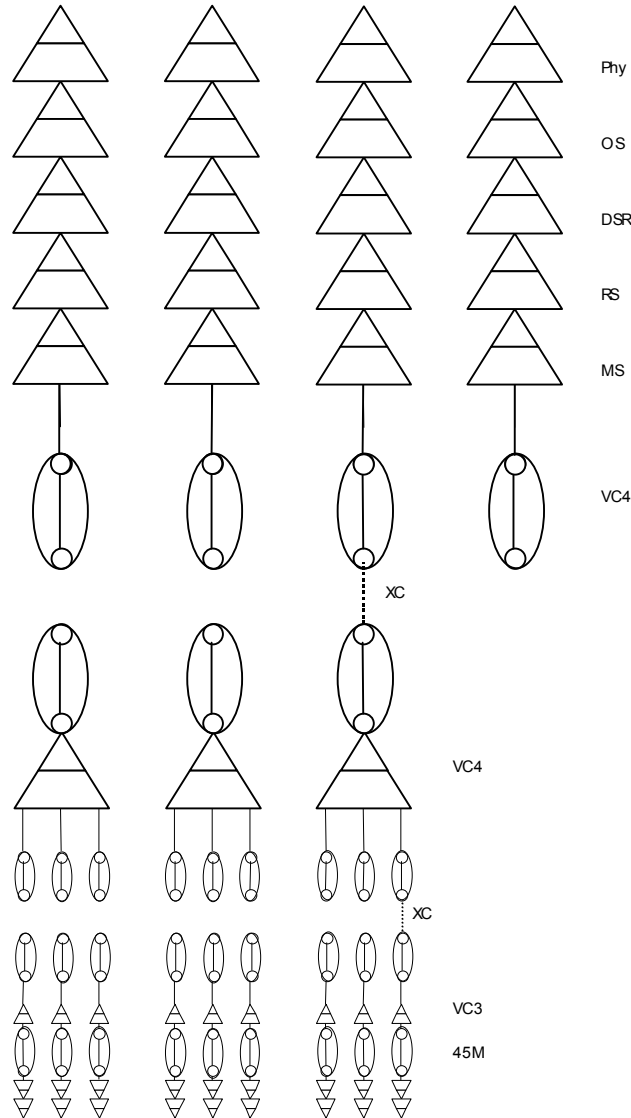
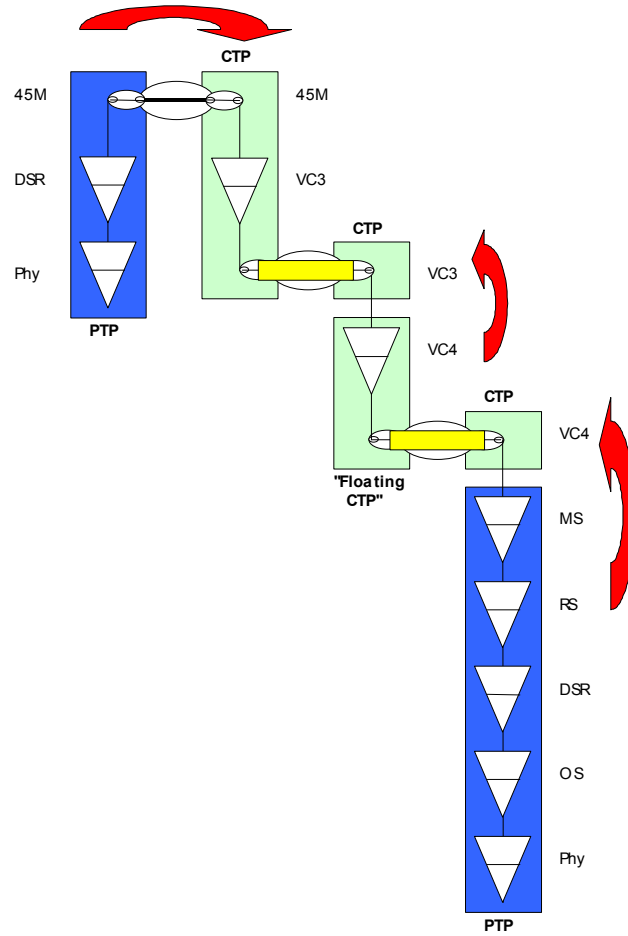

**Figure Error! No text of specified style in document.-5.** G.805 modeling example ("plan" view)

Figure Error! **No text of specified style in document.-6** (elevation), Figure Error! **No text of specified style in document.-7** (plan, generic figure), and Figure Error! **No text of specified style in document.-8** (plan, example of cross-connect) show how FTPs can be used to model managed elements with several layers of flexibility. PTPs are blue, CTPs are green, cross-connections are yellow, and containment relationships are shown by red arrows.

- This is a straightforward mapping from the G.805 model: two cross-connections across physically different matrices are modeled as two different cross-connect objects.
- As can be seen, we find ourselves with a "floating CTP" in the middle that cannot conveniently be attached to the port on either side. This is a VC4 CTP that contains cross-connectable (non-terminated) Low Order CTPs, in our example VC3 CTPs.

# MTNM IMPLEMENTATION STATEMENT TEMPLATES AND GUIDELINES



**Figure** Error! No text of specified style in document.-6. Modeling with Floating CTPs (elevation)

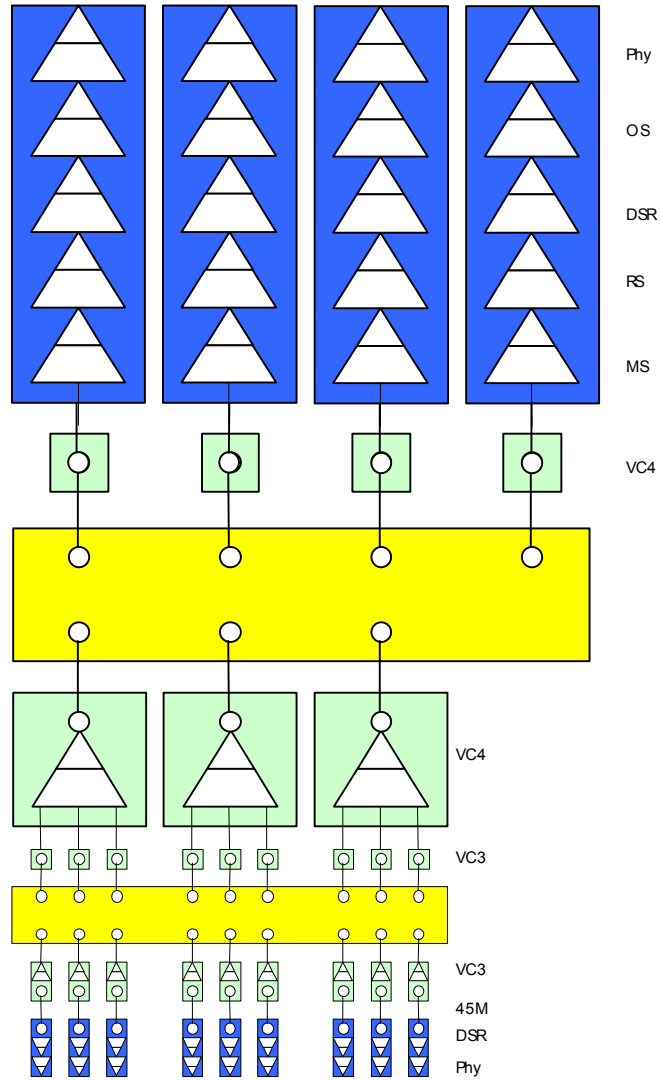
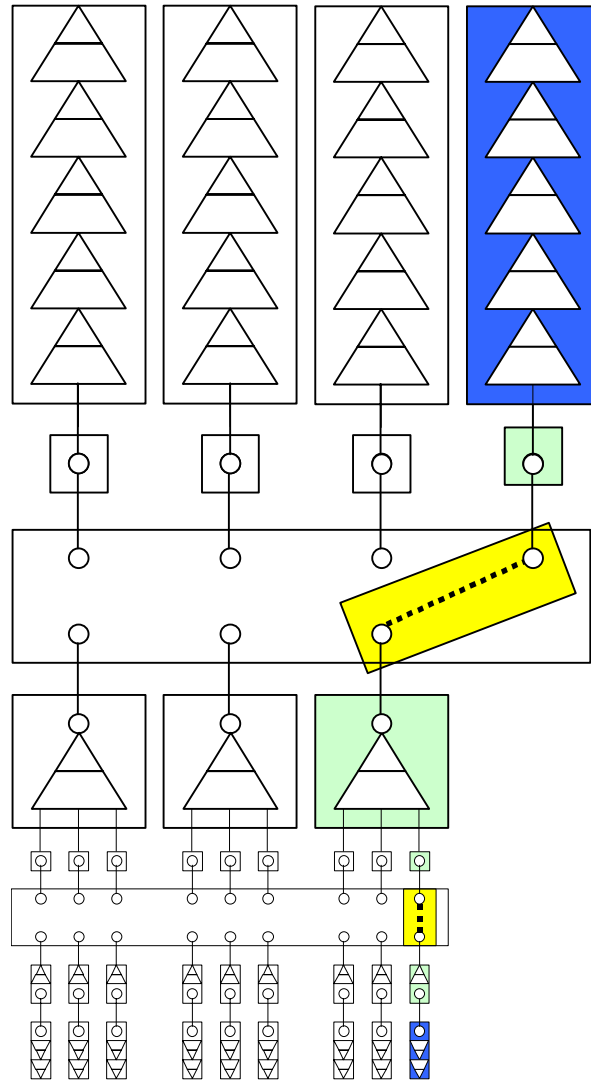

Figure Error! No text of specified style in document.-7. Modeling with Floating CTPs (plan, generic figure)



**Figure Error! No text of specified style in document.-8.** Modeling with Floating CTPs (plan): Example of cross-connects

Another important application of the FTP concept is the end-to-end SNCP protection of a server SNC. We can define a server SNC as a SNC which does not support service, but does provide infrastructure for client SNCs. In the SDH hierarchy, this is the case of a VC4 SNC supporting lower order (TU3/12) SNCs. The end points of the VC4 SNC are terminated and mapped. For example, a VC12 SNC can be supported by a sequence (1 or more) of VC4 SNCs.

Figure **Error! No text of specified style in document.-9** depicts SNCP protection of a server SNC (VC4 layer), where there is no use of FTPs at aEnd or zEnd of the SNC. The protection is partial, i.e., the signals flowing through the topological links at each end of the SNC are not protected.

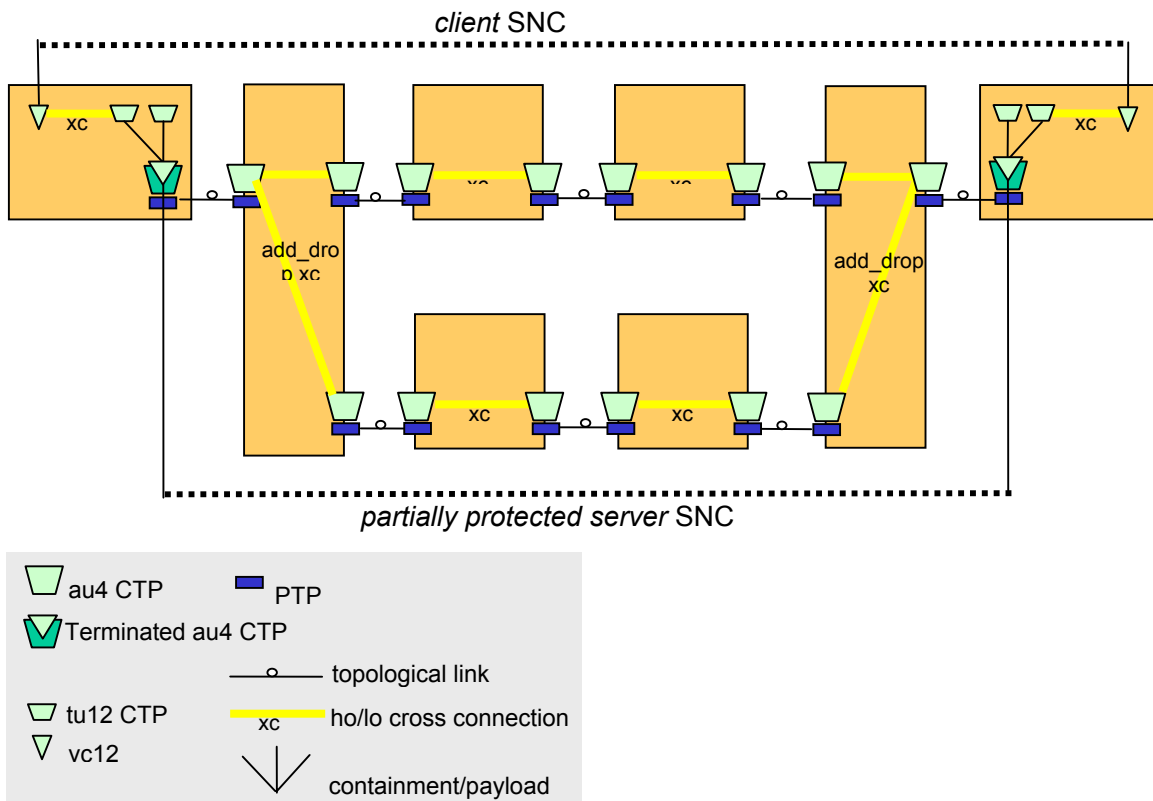

**Figure Error! No text of specified style in document.-9.** Partial SNC Protection without FTPs

Figure **Error! No text of specified style in document.-10** shows the case where FTPs are used to provide protection at each end of the trail. In particular, the MEs at each end have 2 unreliable au4 CTPs which protect the (reliable) VC4 CTP. The trail is terminated by an FTP at each end.

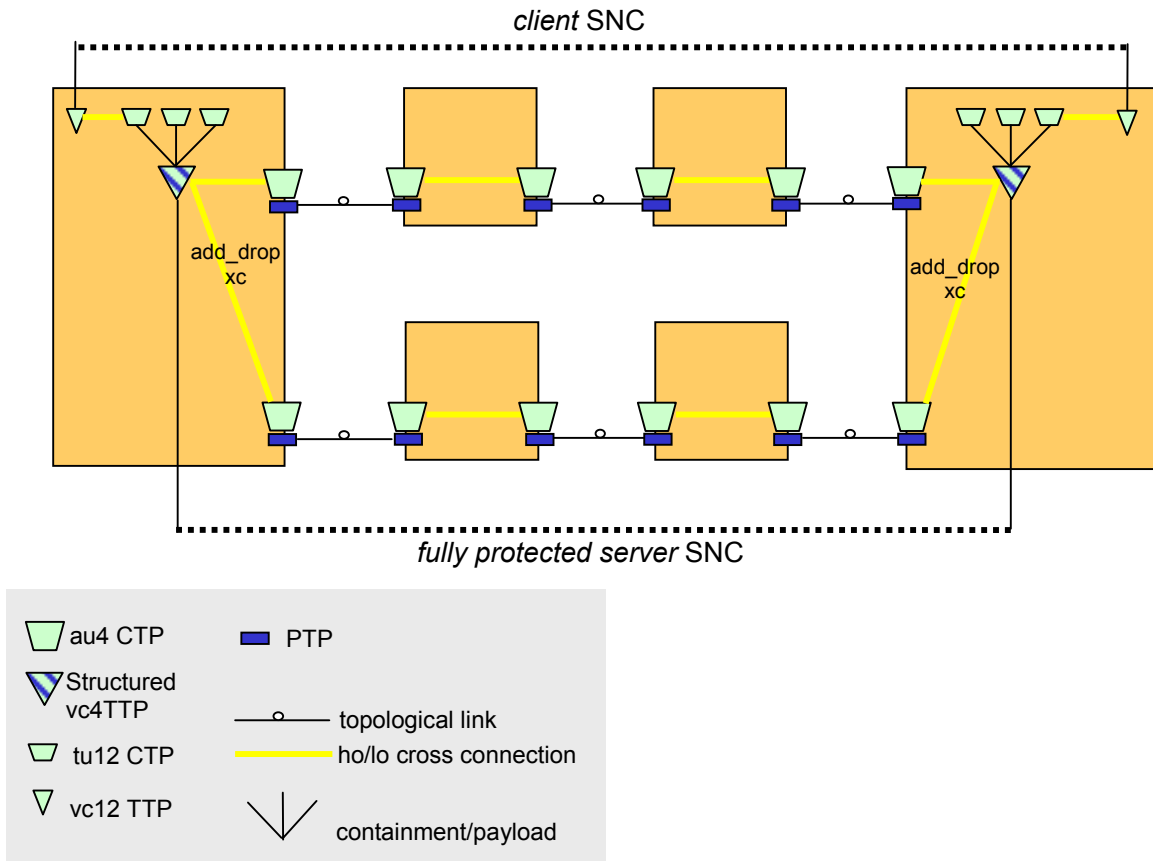

**Figure** Error! No text of specified style in document.-10. Protected Trail using FTPs

# Appendix A: Terms and Abbreviations Used within this Document

## **Terminology**

---

Please refer to

TMF 513 - Multi Technology Network Management (MTNM) Business Agreement,

and

TMF 608 - Multi Technology Network Management (MTNM) Information Agreement.

## **Abbreviations and Acronyms**

---

Please refer to

TMF 513 - Multi Technology Network Management (MTNM) Business Agreement,

and

TMF 608 - Multi Technology Network Management (MTNM) Information Agreement.



## Appendix B:References

### References

---

Reference	Description	Brief Use Summary
<b>Project Charter</b>	MTNM Project Charter v3.0	Used for objectives and scope and for the project benefits.
<b>TMF 513</b>	MTNM Business Agreement. The basic requirements and use cases.	Used for the requirements and use cases references.
<b>TMF 608</b>	MTNM Information Agreement TheUML specification.	Used for information model.
<b>TMF 814</b>	MTNM Solution Set The IDL specification	

### Specific Analysis or Comments on a Source or Use

---

None

### IPR Releases and Patent Disclosures

---

None

## Administrative Appendix

This Appendix provides additional background material about the TeleManagement Forum and this document.

### **About this document**

---

The *Multi-Technology Network Management (MTNM) Implementation Statement Templates and Guidelines* specification is being issued as Member Evaluation Version 3.1. When released, it will be considered valid until further notice by the TeleManagement Forum. At which time the TeleManagement Forum expects to update it to reflect comments from implementation experience, as well as to reflect additional member comment. This version 3.1 MTNM Solution Set will supersede the TMF814 version 3.0 in its entirety.

The purpose of an Evaluation Version is to encourage input based on experience of members and the public as they begin to use the document. Following the Evaluation Period, documents that are seen to deliver value are candidates for formal approval by the TM Forum. All documents approved by the TM Forum (as well as those previously approved by the NMF) undergo a formal review and approval process.

This document will continue under formal change control. Supporting work will be issued as revisions to this document. A document of this type is a “living document,” capture and communicating current knowledge and practices. Further inputs will be made because of detailed work ongoing in the TM Forum and the industry.

This document should be read in conjunction with the following documents:

- TMF513 – MTNM Business Agreement
- TMF608 – MTNM Information Agreement
- TMF814 – MTNM Solution Set
- SD1 series – MTNM Supporting documents

### **Document Life Cycle**

---

#### **Use and Extension of a TM Forum Implementation Statement Template and Guidelines**

This document entails an implementation statement template and set of interoperability guidelines for an NML-EML interface used to enable management of SONET, SDH, WDM and ATM networks. Given that the Multi-Technology Network Management (MTNM) interface defined in TMF814 can be packaged and realized in different ways, this document is intended to provide guidance to those implementing the MTNM interface, with the goal of ensuring interoperability among various vendor implementations.

## MTNM IMPLEMENTATION STATEMENT TEMPLATES AND GUIDELINES

The TMF814A Implementation Statement Template and Guidelines should be used in conjunction with the TMF513, TMF608, the TMF814 and the SD1 series of supporting documents.

It is expected that this document will be used:

- To facilitate interface agreements between Service Providers and vendors
- As input to a service Provider's Request for Information / Request for Proposal (RFx)
- To allow operational support managers to compare their interface requirements with those identified by the project
- As input for companies developing COTS products.
- As a source of requirements for other bodies working in this area.

### **Document History**

## Revision History

ISSUE	DATE	COMMENTS
0.0	18 October 2000	Initial contribution (entitled <i>Proposed Product Profiles for Phase II</i> ) submitted to the November MTNM meeting in Lisle, IL by Telcordia and SBC.
1.5	August 2001	Formatted for Member Evaluation Release
2.0	October 2001	Formatted for TM Forum and Approved after Corporate Vote
2.1	August 2002	Issued v2.1
3.0	August 2003	Submitted v3.0 to TM Forum for subsequently release to the TM Forum membership for evaluation and comment.
3.1	May 2006	<p>Contribution for Ethernet part of the MTNM 3.5 model. The following new IDL modules have been introduced::</p> <ul style="list-style-type: none"> <li>• flowDomain.idl,</li> <li>• flowDomainFragment.idl,</li> <li>• trafficConditioningProfile.idl.</li> </ul> <p>In addition, the following IDL modules have been modified:</p> <ul style="list-style-type: none"> <li>• equipment.idl (no change in this document)</li> <li>• managedElementManager.idl: change to IDL comments =&gt; Termination Point section: change to "Clarification Needed" column for ingressTrafficDescriptorName and egressTrafficDescriptorName attributes.</li> <li>• subnetworkConnection.idl (mainly Control Plane material, no change to this document)</li> <li>• transmissionDescriptor.idl: new operation modifyTransmissionDescriptor =&gt; Transmission Descriptor section: impact on data and interface tables.</li> </ul> <p><b>Note:</b> This document "TMF814A-Ethernet Contribution 20060430.doc" does not contain updates for Control Plane model.</p>
3.1	End May 2006	<p>Updates after bug fixes in Ethernet model:</p> <ul style="list-style-type: none"> <li>• FlowDomain data types: removed fdEdgeCPTPs, also known as assignedCPTPs, from FDCreateData. (The assigned CPTPs can be retrieved via getAllAssignedCPTPs.)</li> <li>• Alarm Severity Assignment Profile data types: attribute fixed is now notModifiable.</li> <li>• New module trafficConditioningProfile.</li> </ul>
3.1	July 2006	<p>Contribution for Control plane part of the MTNM 3.5 model. The following new IDL modules have been introduced:</p> <ul style="list-style-type: none"> <li>• Call SNC module (3 data types: Call, Call Create Data, Call Modify Data)</li> <li>• MLSNPP module (1 data type: MultiLayerSNPP) (1 interface: MLSNPPMgr)</li> <li>• MLSNPP Link module (1 data type: MultiLayerSNPPLink) (1 interface: MLSNPPLinkMgr)</li> </ul> <p>In addition, the following IDL modules have been modified:</p> <ul style="list-style-type: none"> <li>• MultiLayerSubnetwork module (new operations added to</li> </ul>

## MTNM IMPLEMENTATION STATEMENT TEMPLATES AND GUIDELINES

		<p>the Multi-layer Subnetwork Manager interface)</p> <ul style="list-style-type: none"> <li>• MultiLayerSubnetwork module (update Data type: SNCCreateData [Note: In version 3.0 SNCCreateData &amp; SNCModifyData appear in the MultiLayerSubnetwork module of TMF 814A. But the IDL are defined in the SubnetworkConnectin module]) Why? Should this be corrected.</li> <li>• SubnetworkConnection module (update to data types: subnetworkConnection, Cross Connection, Route Create Data)</li> <li>• EmsMgr module (new operations added to the EMSMgr_I interface)</li> </ul> <p>Editorial update to Sections 2 up to 2.1.3</p>
3.1	September 2006	<p>Clean up open questions based on definitive answers from the group.</p> <p>Move the data types SNCCreateData &amp; SNCModifyData back to the SubnetworkConnectin module section so that to be consistent with the IDL.</p> <p>Update front material</p>
3.1	2 October 2006	<p>Change all the operations of the “Multi-Layer Subnetwork Manager” in the FlowDomain Module from Mandatory to Optional.</p> <p>In MLSN module, additionalInfo, change the attribute “LayeredRoutingArea” to “LayeredRoutingArealList”.</p>
3.1	17 October 2006	<p>Changes because of the change for set TNA on MLSNPP &amp; MLSNPPLink</p> <ul style="list-style-type: none"> <li>• In MLSNPP module, delet tNAName and groupTNAName from data type MultilayerSNPP</li> <li>• In MLSNPPLink module MultiLayer SNPPLink data type, replace aEnd and zEnd with aMLRAName and zMLRAName.</li> </ul>
3.1	08 January 2007	<p>Update to align with the changes in the 30/12/2006 and 7/1/2007 IDL</p> <ul style="list-style-type: none"> <li>• For the Flow Domain Module <ul style="list-style-type: none"> <li>– In FDCreateData: add name and transmissionParams</li> <li>– In FlowDomain Modify Data: add transmissionParams</li> <li>– In MatrixFlowDomain: for name, change Set by EMS to Set by E</li> <li>– In MFDCreateData: add name</li> <li>– In MatrixFlowDomain Modify Data: add transmissionParams</li> <li>– In FTP Create Data: delete networkAccessDomain</li> <li>– In Interface: change the heading of Table 2-29 from ‘Multi-layer Subnetwork Manager’ to ‘Flow Domain Manager’; change operation name “getAllTopologicalLinks” to “getAllTopologicalLinksOfFD”; delete the operations addFPsToFDFr, removeFPsFromFDFr, and validateTMDAssignmentToMFD</li> </ul> </li> <li>• For the Call SNC Module <ul style="list-style-type: none"> <li>– In Call Create Data: change callAdditionalInfo to additionalCreationInfo</li> <li>– In Call Modify Data: change callAdditionalInfo to additionalModificationInfo</li> </ul> </li> <li>• For the Multi-Layer Subnetwork Module <ul style="list-style-type: none"> <li>– Change the operation name “getAllSubordinateMLSNWithConnection” to “getAllSubordinateRAidsWithConnection</li> <li>– Add mandatory operation “getCallAndTopLevelConnections”</li> </ul> </li> </ul>

## TM FORUM Implementation Statement (IS) Template and Guidelines

		<ul style="list-style-type: none"> <li>– Delete operation “getMLSNPP”</li> <li>– Delete operation “getAllCallsAndSNCs”</li> <li>– Add optional operation “getAllCallsAndTopLevelConnectionsAndSNCs”</li> <li>– Add optional operation “getAllCallsAndTopLevelConnectionsAndSNCsWithME”</li> <li>• For the Traffic Conditioning Profile Module <ul style="list-style-type: none"> <li>– In the TCProfile datatype, change the attribute name “default” to “defaultProfile”</li> <li>– In the interface, change the following operations from Mandatory to Optional: getAllTCProfiles, getTCProfile, and getTCProfileAssociatedTPs</li> </ul> </li> <li>• For the Transmission Descriptor Module <ul style="list-style-type: none"> <li>– In the TMD Create datatype, change the attribute name “additionalTPInfo” to “additionalObjectInfo”</li> <li>– In the TMD Modification datatype, change the attribute name “additionalTPInfo” to “additionalObjectInfo”</li> <li>– In the Transmission Descriptor Mgr interface: change the operations getAllTransmissionDescriptors, getAllTransmissionDescriptorNames, and getTransmissionDescriptor from mandatory to optional.</li> <li>– In the Transmission Descriptor Mgr interface, add new optional operations validateTMDAssignmentToObject and setTMDAssociation</li> </ul> </li> <li>• Add new Flow Domain Fragment Module</li> </ul>
3.1	February 4, 2007	<ul style="list-style-type: none"> <li>• Align with 2007.01.28 IDL changes to add networkAccessDomain attribute to FTPCreateData_T and remove connectionState attribute from FTPCreateData_T.</li> <li>• Update front matter</li> </ul>
3.1	February 28, 2007	<ul style="list-style-type: none"> <li>• In MultiLayerSubnetwork module, <ul style="list-style-type: none"> <li>– change the operation getCallAndTopLevelConnections from mandatory to optional</li> </ul> </li> <li>• In Call SNC Module <ul style="list-style-type: none"> <li>– Change linkDiversityViolationsList to linkDiversityViolations</li> <li>– Change nodeDiversityViolationsList to nodeDiversityViolations</li> </ul> </li> </ul>
3.1	March 8, 2007	<p>Align with the changes in the IDL distributed on March 7, 2007 (Word Files_2007-03-07)</p> <ul style="list-style-type: none"> <li>• In Flow Domain Module FTP Create Data <ul style="list-style-type: none"> <li>– Change IngressTrafficDescriptorName to ingressTransmissionDescriptorName</li> <li>– Change egressTrafficDescriptorName to egressTransmissionDescriptorName</li> </ul> </li> </ul>
3.1	March 9, 2007	<p>Align with the changes in the IDL as agreed on March 8 (Main open issues_bz)</p> <ul style="list-style-type: none"> <li>• In Flow Domain Module FTP Create Data <ul style="list-style-type: none"> <li>– Delete tpProtectionAssociation and edgePoint</li> </ul> </li> </ul>

## Contacts

---

<b>MTNM Team Leader</b>
Keith Dorking, Ciena
Phone: +1-678-867-5007
Fax: +1-678-867-5010
email: <a href="mailto:Kdorking@ciena.com">Kdorking@ciena.com</a>

<b>MTNM Business Agreement Editor</b>
Keith Dorking, Ciena
Phone: +1-678-867-5007
Fax: +1-678-867-5010
email: <a href="mailto:Kdorking@ciena.com">Kdorking@ciena.com</a>

<b>MTNM Information Agreement Editor</b>
Bernd Zeuner, T-Systems
Phone: +49 6151 937 3709
Fax: +49 6151 937 19875
email: <a href="mailto:bernd.zeuner@t-systems.com">bernd.zeuner@t-systems.com</a>

<b>MTNM CORBA IDL Solution Set Editor</b>
Gerard Vila, Alcatel-Lucent
Phone : +33 1 30 77 78 68
Fax :
email : Gerard.Vila@alcatel-lucent.fr

<b>MTNM Implementation Statement Editor</b>
Kam Lam, Alcatel-Lucent
Phone: +1 732 949 8338
Fax: +1 732 615 4610
email: <a href="mailto:hklam@alcatel-lucent.com">hklam@alcatel-lucent.com</a>

<b>TMF Senior Technical Manager</b>
Stephen Gaito, TM Forum
Phone : +44 2476 693 633
Fax :
email : <a href="mailto:sgaito@tmforum.org">sgaito@tmforum.org</a>

<b>MTNM email address:</b> <a href="mailto:mtnm@lists.tmforum.org">mtnm@lists.tmforum.org</a>
---

## Acknowledgements

The TMF 814A Solution Set, Version 3.5 is a genuinely collaborative effort. The TeleManagement Forum would like to thank the following people for contributing their time and expertise to the production of this document. It is just not possible to recognize all the organizations and individuals that have contributed or influenced the MTNM Implementation Statement Guidelines and Template. We apologize to any person or organization we inadvertently missed in these acknowledgments.

Key individuals that reviewed, provided input, managed, edited and determined how to utilize inputs coming from all over the world, and really made this document happen were:

- Steve Arnott, Ericsson
- Beauford Atwater, Telcordia Technologies
- François Bédard, Nortel Networks
- Ian Best, TM Forum
- Malcolm Betts, Nortel Networks
- Teddy Bezoza, at&t



## MTNM IMPLEMENTATION STATEMENT TEMPLATES AND GUIDELINES

- Alex Bojanic, Tellabs
- Harrie Buiting, Alcatel-Lucent
- Debbie Burkett, TM Forum
- Henri Campagno, France Telecom
- Lily Chen, Verizon
- Lee Chow, Tellabs
- Merav Cohen-Sarussi, ECI Telecom
- Nigel Davis, Nortel Networks
- Keith Dorking, Ciena
- Shane Edmonds, Alcatel-Lucent
- Felix Flemisch, Siemens
- Marianne Franklin, Alcatel-Lucent
- Steve Fratini, Telcordia Technologies
- Einat Gabo-Rafaely, ECI Telecom
- Stephen Gaito, TM Forum
- Salim Galou, Fujitsu
- Elisabetta Gardelli, Siemens
- CB Genrich, Hitachi
- Noam Goldberg, LightScape Networks
- Floyd Goldstein, Alcatel-Lucent
- Alison Greig, Nortel Networks
- Garry Grimes, Ericsson
- Milton Hall, Telcordia Technologies
- Dragan Jovanovic, Acterna
- Roshan Joyce, Fujitsu
- Nathan Kohn, Alcatel-Lucent
- Hing-Kam Lam, Alcatel-Lucent
- Bertrand LeBorgne, Alcatel-Lucent
- François Leroux, Fujitsu
- Tom Ligda, Cisco Systems
- Peter Litz, Siemens
- Astrid Lozano, Nortel Networks
- Menachem Malkosh, ECI Telecom
- Andrea Mazzini, Alcatel-Lucent

## TM FORUM Implementation Statement (IS) Template and Guidelines

➤	Srini	Nangavaram,	Alcatel-Lucent
➤	Frank	O'Rourke,	Ericsson
➤	Sandip	Patel,	Alcatel-Lucent
➤	Noga	Peled,	ECI Telecom
➤	Edgar	Riemann,	Siemens
➤	Jeffrey	Ross,	Fujitsu
➤	Victor	Santos,	Acterna
➤	Horst	Schukat,	Siemens
➤	Eric	Seldner,	Telcordia Technologies
➤	Charles	Sheridan,	Nortel Networks
➤	Sidney	Shiba,	Fujitsu
➤	Wendy	Teller,	Tellabs
➤	Niranjan	Tripathy,	Fujitsu
➤	Alexander	Tschersich,	Siemens
➤	Gerard	Vila,	Alcatel-Lucent
➤	Xuli	Wu,	Tellabs
➤	Bernd	Zeuner,	Deutsche Telekom
➤	Yakov	Zimmerman,	ECI Telecom

Although not directly used within this document, access to documentation and work from standards bodies and other forums have contributed to the evolution of the Multi-Technology Network Management (MTNM) NML-EML Interface. This access was via public information or TM Forum member knowledge. This list of standards bodies and forums is not exhaustive and does not imply review and concurrence by these organizations or their representatives. It is important however to acknowledge the work and their influence on the TeleManagement Forum work:

- American National Standards Institute (ANSI)
- ATM Forum
- DSL Forum
- European Telecommunications Standards Institute (ETSI)
- Institute of Electrical and Electronics Engineers (IEEE)
- International Telecommunications Union - Telecommunication Standardization Sector (ITU-T)
- Internet Engineering Task Force (IETF)
- Metro Ethernet Forum (MEF)
- MPLS and Frame Relay Alliance
- Object Management Group (OMG)

- Optical Internetworking Forum (OIF)

## **About TeleManagement Forum**

TeleManagement Forum is an international consortium of communications service providers and their suppliers. Its mission is to help service providers and network operators automate their business processes in a cost- and time-effective way. Specifically, the work of the TM Forum includes:

- Establishing operational guidance on the shape of business processes.
- Agreeing on information that needs to flow from one process activity to another.
- Identifying a realistic systems environment to support the interconnection of operational support systems.
- Enabling the development of a market and real products for integrating and automating telecom operations processes.

The members of TM Forum include service providers, network operators and suppliers of equipment and software to the communications industry. With that combination of buyers and suppliers of operational support systems, TM Forum is able to achieve results in a pragmatic way that leads to product offerings (from member companies) as well as paper specifications.