



Deploying Your Network in Cisco MGC Node Manager

This chapter provides information about deployment in the following sections:

- Deployment overview
- Device information needed for deployment
- Deploying a Cisco MGC node or farm
 - Overview of deploying a Cisco MGC node or farm
 - Deploying using a seed file
 - Deploying manually
 - Deploying a physical site for the network
 - Deploying the Cisco MGC node object
 - Deploying the network devices
 - Deploying a Cisco MGC farm object
- How Cisco MGC Node Manager discovers device components
- Keeping the Cisco MGC Node Manager network model up to date
 - Deploying new devices
 - Synchronizing the Cisco MGC Node Manager model with device changes
 - Deleting or modifying deployed objects
- Exporting deployment information
 - Creating a seed file
 - Exporting deployment information to an inventory or seed file



Note

For information on troubleshooting deployment errors, see [Appendix C, “Troubleshooting Cisco MGC Node Manager.”](#)

Overview of Deployment

Cisco MGC Node Manager uses the term *deployment* to refer to the addition of objects to the network model. For Cisco MGC Node Manager to be able to manage your network, the Cisco MGC node and its devices must first be deployed. When the device is deployed, an object for each device is created automatically. This created object represents a real object in the network and is accessible under the Physical and device-specific views in the Map Viewer.



Note

The other task in setting up the management of your network is configuration of the managed devices so that they forward alarms to Cisco MGC Node Manager. Typically, this is done by the system administrator. Deployment tells Cisco MGC Node Manager how to communicate with the managed devices; configuration tells the devices how to communicate with Cisco MGC Node Manager. See [Chapter 2, “Configuring Network Devices for Management”](#) for details.



Note

For a BAMS to be deployed into the correct node, two things must happen: (1) It must have been configured to collect call detail records for the relevant Cisco MGC host residing in the same node; (2) It must actively poll call detail records from that Cisco MGC host (set the “activate” flag to “1” in BAMS to start the process). When deployed, the BAMS is then automatically placed in the node containing that host. This is dynamically updated: If you de-activate polling, Cisco MGC Node Manager removes the BAMS object from the node; when you re-activate polling, it restores the BAMS object to the node.

You deploy an object by giving Cisco MGC Node Manager the basic information needed to manage the device, such as the IP address and login ID and password. If you are using SSH in your managed network and have installed SSH for Cisco MGC Node Manager, you also specify the security policy of components that can be SSH-enabled:

- The Cisco MGC host
- BAMS
- HSI server
- Integrated SLT
- Cisco Catalyst 5500 and 6509 LAN switches

You can deploy a Cisco MGC node and its devices in either of two ways:

- Manually, using a deployment template to fill in details for each device individually
- With a seed file, specifying deployment information for a group of devices in an external seed file that is read by Cisco MGC Node Manager

After you deploy a device, whether manually or with a seed file, Cisco MGC Node Manager contacts the device and discovers information about its configuration. For example, when a Cisco SLT is deployed, Cisco MGC Node Manager discovers any TDM (DS1) interfaces. When a Cisco LAN Switch is deployed, Cisco MGC Node Manager discovers ports and modules. When the Cisco MGC host is deployed, Cisco MGC Node Manager discovers the system components as well as signaling, trunking, and dial plan components.

You carry out deployment for the entire Cisco MGC node or farm when you first set up Cisco MGC Node Manager. Later you deploy a new device to the network, on a device-by-device basis. To keep the Cisco MGC Node Manager model synchronized with changes in device configurations, you can define a frequency for auto-rediscovery or manually rediscover device components after making changes. The default frequency for rediscovery is 6 hours.

You can also save a copy of your deployed network model, as a seed file, to use when adding new devices to the network. The seed file can be modified with a text editor to copy or add new device addresses and passwords and export the network information in an inventory file. For more information, see the [“Exporting Deployment Information to an Inventory or Seed File”](#) section on page 5-22.

Information Needed for Deployment

Whether you are deploying components with a seed file or manually, Cisco MGC Node Manager needs the same information about the network. [Table 5-1](#) summarizes the information needed. The first column shows the attribute name in the seed file, and the second column shows the field name in the Deployment template.

Table 5-1 Deployment Information

Attribute in Seed File	Attribute in Deployment Template	Applicable Device Types	Description	Seed File Default	Required?
name	Name	All	A name for the object in Cisco MGC Node Manager. The name must be unique in the network.	None for Cisco MGC node, HSI server, and BAMS. For node devices: Device type-IP address (for example, Host-10.10.10.0 for a Cisco MGC host).	In manual deployment: Yes for all. In seed file deployment: Yes for Cisco MGC node, HSI server, and BAMS. No for node devices (host, Cisco SLT, LAN Switch; default will be used).
ip	IP Address	All except the Cisco MGC node or farm	IP Address of the network element.	None	Yes.
read	Read Community	All except Cisco MGC node or farm	SNMP read-community string.	public.	In manual deployment: Yes. In seed file deployment, you can enter this in the file or in the dialog box.

Table 5-1 Deployment Information (continued)

Attribute in Seed File	Attribute in Deployment Template	Applicable Device Types	Description	Seed File Default	Required?
write	Write Community	All except Cisco MGC node or farm	SNMP write-community string.	private.	In manual deployment: Yes. In seed file deployment, you can enter this in the file or in the dialog box.
location	View - Object Relationship	All except farm	A name for the physical site, used in Cisco MNM to organize objects in the Physical view. The same name should be used for all devices to be grouped in a given Physical view.	default Note If you omit the name from some devices, devices are placed in two different physical sites, one with the default name and one with the name you supply.	In manual deployment: Yes. In seed file deployment: No (default will be used).
securitypolicy	Security Policy	All except Cisco MGC node and farm, specific devices at end of life that do not support SSH (standalone SLT, Catalyst 2900 XL)	The security policy used on the device, either none or SSH. With SSH selected, Cisco MGC Node Manager determines the correct SSH version for communication with the device.	“None”	In manual deployment: Yes. In seed file deployment: No (default will be used).

In seed file deployment, for security reasons the next four attributes should be entered in the Deploy Network dialog box when you deploy the seed file rather than being included in the file.

login	Login	All except Cisco MGC node or farm	Login ID for the device software. For the Cisco MGC host, for example, this is the login used.	In seed file: Cisco MGC host: mgcur BAMS: acec HSI server: cisco	Yes.
password	Password	All except Cisco MGC node or farm	Password to log in to the device software.	None.	Yes.

Table 5-1 Deployment Information (continued)

Attribute in Seed File	Attribute in Deployment Template	Applicable Device Types	Description	Seed File Default	Required?
root	Root Password	Cisco MGC host, BAMS, HSI server	Root (super-user) password for the device software.	None.	Yes.
enable	Enable Password	Cisco SLT and Cisco LAN Switch	SLT and Catalyst software enable password.	None.	Yes.

Deployment Rules

Cisco MGC Hosts

You can define a maximum of two hosts per Cisco MGC node, the active and standby Cisco MGC hosts. You do not have to specify which host is active or standby; this is determined automatically by Cisco MGC Node Manager. You must specify the name for each Cisco MGC node.



Caution

Although Cisco MNM does not prevent you from deploying more than two hosts per node, the system is not designed to support this configuration.

Cisco MGC Farms

You can define from one or more Cisco MGC nodes under a Cisco MGC farm.

Physical Locations and Deployment

When a device is deployed, it is placed into the Physical containment tree for its location. For example, all devices with location=Chicago are placed under a site object named Chicago. If the specified location does not exist, Cisco MGC Node Manager automatically deploys a site object with the specified location name. If you do not specify a physical location for a device, it is deployed in the same location as its logical parent. If no location is specified for the parent, the objects are deployed to a site called Default.

Cisco MGC node objects and farm objects are not physical devices and, as such, are not deployed into the Physical containment tree. You may specify a location for the Cisco MGC node or farm, however, so that children of the node can, by default, be placed in the specified location. For example, if you specify that a Cisco MGC node is in the site Cincinnati, all of its children that do not specifically specify a location are, by default, placed in the Cincinnati site.

Seed File Deployment

A *seed file* is a text file containing the names and IP addresses of all of the devices in the Cisco MGC network, together with the relationship (hierarchy) between the devices. For bulk deployment, you can use a seed file to deploy an entire Cisco MGC network consisting of one or more Cisco MGC nodes or farms. Using this file, Cisco MGC Node Manager automatically deploys all the elements in the network.

**Note**

A seed file requires the name and IP address for each device to be deployed, and it can optionally contain the userid and password necessary to log in to the device.

To perform seed file deployment, launch a dialog from a MGC-Node-View node or other type of object in the Map Viewer. This dialog prompts you for the name of the seed file and, if not specified in the seed file, for the login ID and password for each device type. You also specify SNMP read- and write-community strings for the Cisco SLT and Cisco LAN Switch.

**Note**

A sample seed file is located at `<CEMF Root>/samples/seedfile.txt` and in [Example 5-1](#).

Seed File Example and Syntax

Sample seed files are shown in [Example 5-1](#) (seed file for Cisco MGC node) and [Example 5-2](#) (seed file for Cisco MGC farm).

The examples are followed by an explanation of the required syntax. You can also view a sample seed file at `<CEMF Root>/samples/seedfile.txt`.

**Note**

By default, Cisco MNM looks for the seed file in the `<CEMF Root>/bin/.mgcControllerx.sysmgr` folder. If you place the file elsewhere, note the location; you will need to specify the location in the Deploy Network dialog box.

Seed File Examples

Example 5-1 Sample Seed File for Cisco MGC Node

```
# Sample MGC Network Seed File

MGC (name = mgc-node-1) {
  HOST (name = mgc-host-1, location = Site-1, ip = 10.1.1.1, securitypolicy = none)
  HOST (name = mgc-host-2, location = Site-1, ip = 10.1.2.1, securitypolicy = none)
  2600 (name = slt-1, location = Site-1, ip = 10.1.1.2, securitypolicy = none)
  2600 (name = slt-2, location = Site-1, ip = 10.1.2.2, securitypolicy = none)
}
2900x1 (name = lanswitch-1, location = Site-1, ip = 10.1.1.3, securitypolicy = none)
5500 (name = lanswitch-2, location = Site-1, ip = 10.1.2.3, securitypolicy = none)
MGC (name = mgc-node-2) {
  HOST (name = mgc-host-3, location = Site-1, ip = 10.1.3.1)
  HOST (name = mgc-host-4, location = Site-1, ip = 10.1.4.1)
  INTEGRATED_SLT (name = slt-3, location = Site-1, ip = 10.1.1.3, securitypolicy = ssh)
  INTEGRATED_SLT_CORESIDENT (name = slt-4, location = Site-1, ip = 10.1.2.4,
securitypolicy = SSH)
}

6509 (name = lanswitch-5, location = Site-1, ip = 10.1.4.3, securitypolicy = ssh)
BAMS (name = bams-1, location = Site-1, ip = 10.10.3.1, securitypolicy = ssh)
HSI (name = gwing-1, location = Site-1, ip = 10.10.3.2, securitypolicy = ssh)
```

Example 5-2 Sample Seed File for Cisco MGC Farm

```
# Sample MGC Seed File including a Farm

BAMS (name = bams-mast, location = bams-mast, ip = 10.18.126.102, securitypolicy = none)
FARM (name=MGCFarm-1)
{
  MGC (name=MGC-vsc9)
  {
    HOST (name = nssuvsc9, location = nssuvsc9, ip = 10.18.126.59, securitypolicy = none)
  }
}

BAMS (name = bams-sla, location = bams-sla, ip = 10.18.126.103, securitypolicy = none)
HSI (name = HSI-218, location = HSI-218, ip = 10.18.126.218, securitypolicy = none)
5500 (name = 5509, location = 5509, ip = 10.18.126.5, securitypolicy = none)
MGC (name=MGC-slt)
{
  2600 (name = slt-b, location = slt-b, ip = 10.18.126.10, securitypolicy = none)
}

```

Seed File Syntax

The specifications for each Cisco MGC host, Cisco SLT, and Cisco LAN switch are grouped under the relevant Cisco MGC node.

For a Cisco MGC farm, the specifications for each Cisco MGC node in the farm are grouped under the farm specification. The specifications for each Cisco MGC host are grouped under the appropriate node.

**Note**

A node associated with a farm includes Cisco MGC hosts only.

The specification for each BAMS or HSI server must be specified on its own line; the Cisco MNM determines the node with which the HSI server or BAMS is associated at deployment.

For each Cisco MGC node:

```
MGC (name=mgcnodename, location=Physical site) {Values for Cisco MGC node devices}
```

For each Cisco MGC farm:

```
FARM (name=mgcfarmname, location=Physical site) {Values for Cisco MGC node and host}
```

Enclosed in braces under a node, the values for Cisco MGC node devices:

- For each Cisco MGC host:

```
HOST ([name=Cisco MGC host name,] ip=IP address, [read=public,]
[write=private,] [location=Physical site,] [securitypolicy=Securitypolicy])
```

- For each Cisco SLT:

```
2600 ([name=Cisco SLT name,] ip=IP address, [read=public,] [write=private,]
[location=Physical site,] [securitypolicy=Securitypolicy])
```

- For each Cisco INTEGRATED SLT:

```
INTEGRATED_SLT ([name=Cisco SLT name,] ip=IP address, [read=public,]
[write=private,] [location=Physical site,] [securitypolicy=Securitypolicy])
```

- For each co-resident Cisco INTEGRATED SLT:

```
INTEGRATED_SLT_CORESIDENT([name=Cisco SLT name,] ip=IP address, [read=public,]
[write=private,] [location=Physical site,] [securitypolicy=Securitypolicy])
```

- For each Cisco 2900XL LAN Switch, on its own line:

```
2900XL ([name=Cisco LAN Switch name,] ip=IP address, [read=public,]
[write=private,] [location=Physical site,] [securitypolicy=Securitypolicy])
```

- For each Cisco 5500XL LAN Switch, on its own line:

```
5500 (ip=IP address, [name=Cisco LAN Switch name,] [read=public,] [write=private,]
[location=Physical site,] [securitypolicy=Securitypolicy])
```

- For each Cisco 6509XL LAN Switch, on its own line:

```
6509 (ip=IP address, [name=Cisco LAN Switch name,] [read=public,] [write=private,]
[location=Physical site,] [securitypolicy=Securitypolicy])
```

- For each HSI server, on its own line:

```
HSI ([name=HSI host name,] ip=IP address, [location=Physical site,]
[securitypolicy=Securitypolicy])
```

- For each BAMS, on its own line:

```
BAMS ([name=BAMS name,] ip=IP address, [location=Physical site,]
[securitypolicy=Securitypolicy])
```

**Note**

If the BAMS has been configured to collect call detail records (CDRs) for a Cisco MGC host, the BAMS is deployed in the node containing that host. To appear in that node, it must be actively polling CDRs.

Deploying a Network Using a Seed File

Use the following procedure to deploy a network using a seed file:

-
- Step 1** Create a seed file manually or generate a seed file with the Cisco VSPT. For seed file attributes, see [Table 5-1](#). For seed file syntax, see the “[Seed File Example and Syntax](#)” section on page 5-6. Note the location of the seed file.
 - Step 2** From the Map Viewer screen, select the MGC-Node-View icon.
 - Step 3** Right-click, and choose **Deployment > Deploy Network Seed File**.
You see the screen in [Figure 5-1](#).

Figure 5-1 Deploy Network Screen—Seed File Tab

The screenshot shows the 'Deploy Network' window with the following details:

- Seed File Tab:**
 - Instruction: Specify the name of the MGC Node network seed file.
 - Field: Filename:
- Accounts Tab:**
 - Instruction: Specify the account information for each type of device. These values will be used as defaults for those fields not specified in the seed file.
 - Table:

	MGC Host	SLT	LAN Switch	BAMS	HSI
Login ID:	<input type="text" value="mgcusr"/>	<input type="text"/>	<input type="text"/>	<input type="text" value="bams"/>	<input type="text" value="user"/>
Password:	<input type="text"/>	<input type="text"/>	<input type="text"/>	<input type="text"/>	<input type="text"/>
Enable Password:	<input type="text"/>	<input type="text"/>	<input type="text"/>	<input type="text"/>	<input type="text"/>
Read Community:	<input type="text" value="*****"/>	<input type="text" value="*****"/>	<input type="text" value="*****"/>	<input type="text" value="*****"/>	<input type="text" value="*****"/>
Write Community:	<input type="text" value="*****"/>	<input type="text" value="*****"/>	<input type="text" value="*****"/>	<input type="text" value="*****"/>	<input type="text" value="*****"/>

Buttons: **Deploy...**

Status: mgcController (normal) Dynamic updates are enabled

Step 4 In the Filename field, enter the name of the seed file.



Note If the file is not in the default location, <CEMF Root>/bin/.mgcControllerx.sysmgr, include the path.

Step 5 Enter the software login information for each type of device.

Step 6 (Optional) To enter advanced information, such as SNMP configuration parameters, click the **Advanced** tab. Click the **Seed File** tab when you are done.

Step 7 Click **Deploy**.

You are prompted to confirm the deployment.

Step 8 Click **Yes**.

The system displays the message “The network has been successfully deployed”, and Cisco MNM goes on to discover the device subcomponents. See the [“About the Discovery Process”](#) section on page 5-14 for details on what happens during discovery.

**Note**

If you receive an error message, see [Table C-2](#) in [Chapter](#) , “[Troubleshooting Cisco MGC Node Manager](#).”

Manual Deployment

Cisco MGC Node Manager defines a number of templates that allow you to manually configure Cisco MGC nodes and other objects including:

- Cisco MGC node
- Cisco MGC host or host pair as a child of the Cisco MGC node
- Top-level BAMS
- HSI server
- Cisco SLT as a child of a Cisco MGC node
- Cisco LAN switch
- Cisco MGC farm
- Cisco MGC node or multiple nodes as children of the Cisco MGC farm

The Deployment Wizard reads the templates and presents screens prompting you for information about the devices.

Overview of Steps to Deploy a Cisco MGC Node Manually

Task 1. If one does not already exist, deploy a physical site as the container for the node.

Task 2. Deploy a Cisco MGC node object.

Task 3. Deploy each of the devices that the node contains (Cisco MGC host, Cisco SLT, Cisco LAN Switch).

Task 4. If applicable, deploy the BAMS.

Task 5. If applicable, deploy the HSI server.

**Note**

Only one deployment wizard per user can be open at any time. If you attempt to open a second wizard, a message advises you that the deployment wizard is already active. Complete the first deployment task before proceeding.

Overview of Steps to Deploy a Cisco MGC Farm Manually

Task 1. If one does not already exist, deploy a physical site as the container for the node.

Task 2. Deploy a Cisco MGC farm object.

Task 3. Deploy each of the Cisco MGC nodes that the farm contains.

Task 4. For each node, deploy each of the devices that the node contains (Cisco MGC host, Cisco SLT, Cisco LAN Switch).

Task 4. If applicable, deploy the BAMS.

Task 5. If applicable, deploy the HSI server.

**Note**

Only one deployment wizard per user can be open at any time. If you attempt to open a second wizard, a message advises you that the deployment wizard is already active. Complete the first deployment task before proceeding.

Deploying a Physical Site

Use the following procedure to deploy a physical site as the container for a Cisco MGC node:

-
- Step 1** Open the Map Viewer.
 - Step 2** In the left pane, right-click the **Physical** view icon.
 - Step 3** Choose **Deployment > Deploy Generic Objects**.
The Deployment Wizard Templates window appears showing a list of templates.
 - Step 4** Select **Site**, and click **Forward**.
The Object Parameters window appears.
 - Step 5** Specify the number of sites you are creating, or accept 1 as the default, and click **Forward**.
 - Step 6** Enter the name you want to use for the physical site (no spaces). Click **Forward**.
The Deployment Wizard Views window appears.
 - Step 7** Click **Select**.
 - Step 8** In the Object Selector window, select the Physical object, and click **Forward**.
You see a screen that summarizes the deployment you have created.
 - Step 9** Click **Finish**.
You are informed if the deployment was successful. A physical site icon appears on the right pane of the Map Viewer window.
 - Step 10** Deploy the Cisco MGC node object as described in the [“Deploying a Cisco MGC Node Object”](#) section on page 5-11.
-

Deploying a Cisco MGC Node Object

Use the following procedure to deploy a Cisco MGC node object:

-
- Step 1** Open the Map Viewer.
 - Step 2** In the left pane, right-click the **MGC-Node-View** icon.

- Step 3** Choose **Deployment > Deploy MGC Node**.
The Deployment Template appears.
- Step 4** Enter the name for the Cisco MGC node (no spaces). Click **Forward**.
You see a screen that summarizes the deployment you have created and allows you to commit or reject the deployment.
- Step 5** Click **Finish**.
You are informed if the deployment was successful. A Cisco MGC node icon appears on the right pane of the Map Viewer window.
- Step 6** Deploy the devices in the node as described in the [“Deploying Network Devices” section on page 5-12](#).
-

Deploying Network Devices

Use the following procedure to deploy a Cisco MGC host, Cisco SLT, Cisco LAN Switch, HSI server, or BAMS:

- Step 1** Open the Map Viewer.
- Step 2** In the left pane, expand the MGC-Node-View icon and click to select the desired Cisco MGC node.



Note Although you can alternatively begin deployment from the device-specific view, starting from the appropriate node avoids having to specify the node relationship in the deployment template.

- Step 3** Right-click the **MGC node** icon and choose **Deployment > Deploy MGC Node Component**.

The Deployment Wizard Templates window appears listing these template types:

- BAMS
- 2900XL Switch
- Catalyst 5500 Switch
- Catalyst 6509 Switch



Note Although the Cisco Catalyst switches listed above can be deployed using the Deploy MGC Node Component Wizard, when deployed they do not appear as children of the node.

- HSI Host
- MGC Host
- MGC Node
- SLT
- Integrated SLT
- Integrated SLT for Coresident EMs



Note You cannot deploy an SLT or integrated SLT in a node that is under a farm object.

- Step 4** Select the desired device type, and click **Forward**.
The Deployment Wizard Object Parameters window appears.
- Step 5** Enter device data. See [Table 5-1 on page 5-3](#) for descriptions of the fields.
- Step 6** Click **Forward**.
The Deployment Wizard Views screen appears.
- Step 7** Click **Select**.
The Object Selector appears.
- Step 8** Click the + (shown in [Figure 5-2](#)) to show the physical site(s) in the Physical View.

Figure 5-2 Expanding the Physical Site View

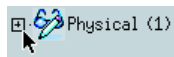

- Step 9** Select the physical site for the current node, and click **Apply**.
- Step 10** Click **Finish**.

An icon for the new device appears on the right pane of the Map Viewer. Cisco MGC Node Manager begins discovering the device, as shown by the crosshatching of the object icon, and the discovering status indicator attached to it. Here is an example:

Figure 5-3 Device in Discovering State



For a Cisco MGC host, Cisco SLT, or Cisco LAN Switch, the device icon also appears on the left pane in the MGC-Node-View as a child of the current Cisco MGC node. If the BAMS is configured to send call detail records (CDRs) to the Cisco MGC host, and is actively polling CDRs, the BAMS icon also appears as a child of the node.

When discovery is complete, Cisco MNM sends a “Discovery is now complete” alarm that can be viewed in the Event Manager.

See the [“About the Discovery Process” section on page 5-14](#) for details on what happens during discovery.



Note The icon for the new object also appears in the Physical View and device specific view for its device type.



Note For information on troubleshooting deployment errors, see [Appendix C, “Troubleshooting Cisco MGC Node Manager,” “Solving Deployment and Discovery Errors” section on page C-5](#).

About the Discovery Process

After you deploy a device, Cisco MGC Node Manager contacts the device and discovers information about its configuration. For example, when you deploy a Cisco SLT, Cisco MGC Node Manager discovers any Ethernet and TDM (DS1) interfaces and their IP addresses. When you deploy a Cisco LAN Switch, Cisco MGC Node Manager discovers interfaces, ports, and modules. When you deploy the Cisco MGC host, Cisco MGC Node Manager discovers the system components, as well as signaling, trunking, and dial plan components. [Figure 5-4](#) shows how the Cisco MGC host appears in the Map Viewer after discovery.

Figure 5-4 Map Viewer Appearance of the Cisco MGC Host After Discovery

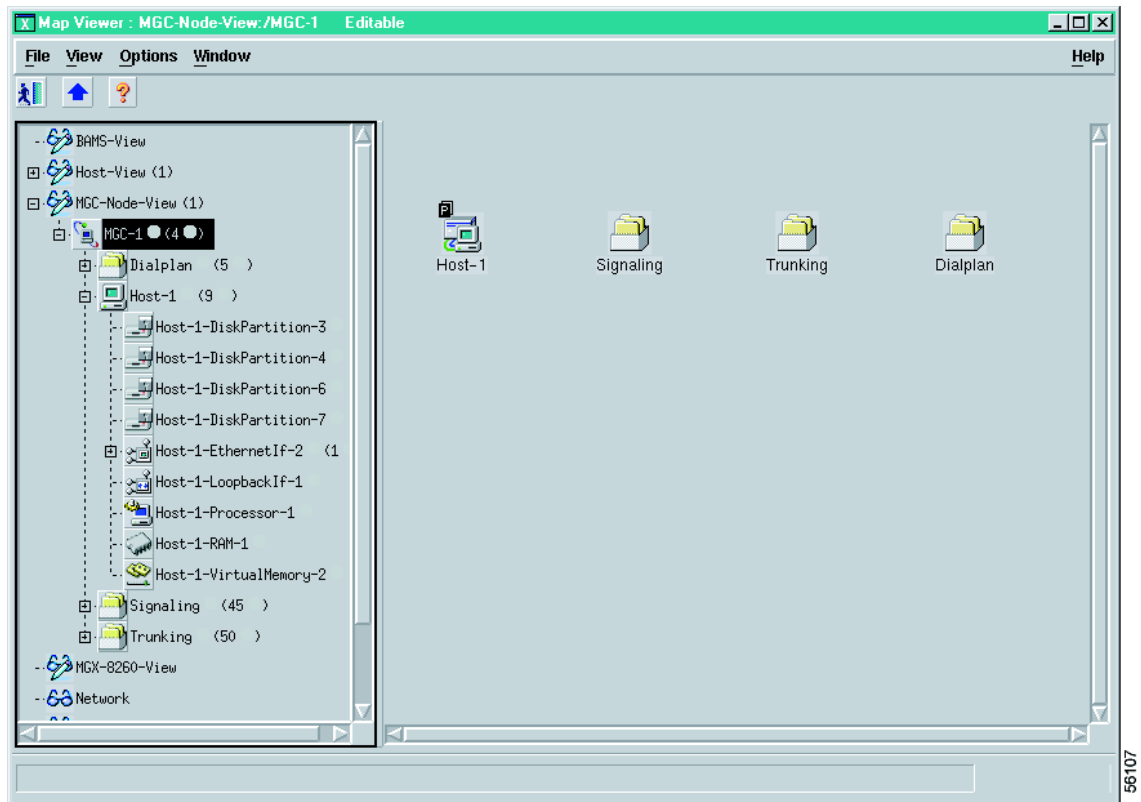

The various subcomponent discovery mechanisms are described in the following sections.



Note

After initial deployment, Cisco MGC Node Manager automatically rediscovers each device at a predefined interval and keeps track of the time that each device was last discovered. The default interval for automatic rediscovery is every 6 hours. When the specified interval has elapsed, Cisco MGC Node Manager automatically rediscovers the device. See the [“Synchronizing the Cisco MGC Node Manager Model with Device Changes”](#) section on page 5-20 for details.

Discovery of Cisco MGC Host, HSI Server, and BAMS Components

The Cisco MGC host, HSI server, and BAMS discovery mechanism processes the ifTable of the device and deploys an object to represent each supported interface. BAMS also uses the CIAgent system component discovery mechanism. In addition, an object representing each (non-loopback) IP address is deployed as a child of its corresponding interface as shown in [Figure 5-5](#).



Note

For a BAMS to be deployed into the correct node, two things must happen: (1) It must have been configured to collect call detail records for the relevant Cisco MGC host residing in the same node; (2) It must actively poll call detail records from that Cisco MGC host (set the “activate” flag to “1” in BAMS to start the process). When deployed, the BAMS is then automatically placed in the node containing that host. This is dynamically updated: If you de-activate polling, Cisco MNM removes the BAMS object from the node; when you re-activate polling, it restores the BAMS object to the node.

Figure 5-5 Cisco MGC Host, HSI Server, and BAMS Discovery

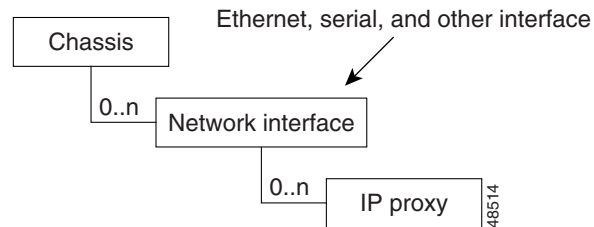

Discovery of System Components

For the Cisco MGC host, HSI server, and BAMS, system components are deployed that represent logical components of the UNIX system, as shown in [Table 5-2](#).

Table 5-2 Components Deployed

Component Type	Description
RAM	Physical RAM in the UNIX machine
virtualmem	Virtual memory storage
Fixed disk	Local (non-ncs mounted) disk drive
Processor	Processor (CPU)

Discovery of Cisco MGC Host Signaling, Trunking, and Dial Plan Components

Cisco MGC Node Manager models and displays the trunking, signaling, and dial plan components associated with the active Cisco MGC host. When Cisco MGC Node Manager initially discovers a new Cisco MGC host, it retrieves the configuration for the active Cisco MGC host by using Telnet to connect to the active host, starting an MML session, and running the **prov-exp** command. This command puts the current configuration of the Cisco MGC host in a number of flat files as described in [Table 5-3](#).

Each entry in the `c2900ModuleTable` is modeled as a `switch2900XLSlot` object. The attribute `SNMP:CISCO-C2900-MIB.c2900ModuleIndex` serves as an index into the table.

Each entry in the `c2900PortTable` is modeled as a `switch2900XLPort` object. In the Cisco MGC Node Manager object model, it is placed under its dependent slot. The `c2900PortTable` is indexed by two attributes, the module index and the port index. The module index indicates on which slot the port resides. Module index zero indicates that the ports are dependent on the chassis rather than a slot. The attribute `c2900PortIfIndex` is used to correlate the `c2900PortTable` to the `ifTable`.

Each entry in the `vtpVLANTable` is modeled as a `switch2900XLVLAN`. In addition, each interface associated with the VLAN is displayed as a child of its corresponding VLAN. In order to correlate interfaces from the `ifTable` to their corresponding VLANs in the `vtpVLANTable`, Cisco MGC Node Manager uses the description of the `ifTable` entry, which is of the form:

VLAN x

Where x is the index of the corresponding entry in the `vtpVLANTable`.

The Cisco 2900XL subrack component appears as shown in [Figure 5-7](#).

Figure 0-1 Cisco 2900XL Chassis Discovery

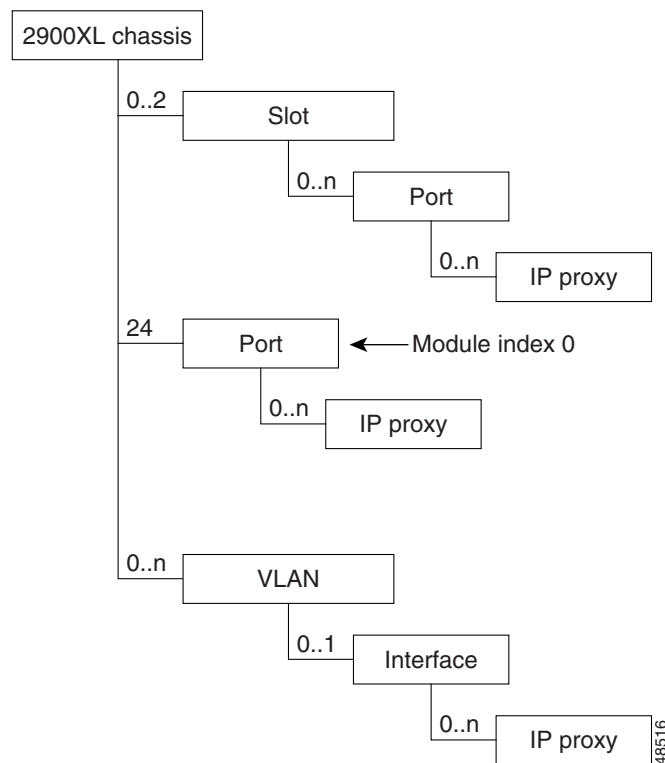

Discovery of Cisco Catalyst 5500 and 6509 Components

Cisco MGC Node Manager models slots, VLANs, and ports on Cisco Catalyst 5500 and 6509 series devices. During auto discovery, Cisco MGC Node Manager retrieves the tables shown in [Table 5-5](#).

Discovery of Cisco 2900XL Components

Cisco MGC Node Manager models ports and modules (slots) on Cisco 2900XL series devices. The Cisco 2900XL has 24 ports built into the chassis. In addition, the Cisco 2900XL has two slots into which different cards can be installed.

During auto-discovery, Cisco MGC Node Manager retrieves the tables shown in [Table 5-4](#).

Table 5-4 Cisco 2900XL Discovery Tables

Table	Description
CISCO-C2900-MIB.c2900ModuleTable	Contains all of the module (slot) information
CISCO-C2900-MIB.c2900PortTable	Defines all of the ports on the chassis
SNMPv2-MIB.ifTable	Defines all of the interfaces on the chassis
RFC1213-MIB.ipAddrTable	Lists all IP address on a port
CISCO-VTP-MIB.vtpVlanTable	Lists all VLANs on the chassis

Each entry in the c2900ModuleTable is modeled as a switch2900XLSlot object. The attribute SNMP:CISCO-C2900-MIB.c2900ModuleIndex serves as an index into the table.

Each entry in the c2900PortTable is modeled as a switch2900XLPort object. In the Cisco MGC Node Manager object model, it is placed under its dependent slot. The c2900PortTable is indexed by two attributes, the module index and the port index. The module index indicates on which slot the port resides. Module index zero indicates that the ports are dependent on the chassis rather than a slot. The attribute c2900PortIfIndex is used to correlate the c2900PortTable to the ifTable.

Each entry in the vtpVLANTable is modeled as a switch2900XLVLAN. In addition, each interface associated with the VLAN is displayed as a child of its corresponding VLAN. In order to correlate interfaces from the ifTable to their corresponding VLANS in the vtpVLANTable, Cisco MGC Node Manager uses the description of the ifTable entry, which is of the form:

VLAN x

Where x is the index of the corresponding entry in the vtpVlanTable.

The Cisco 2900XL subrack component appears as shown in [Figure 5-7](#).

Figure 5-7 Cisco 2900XL Chassis Discovery

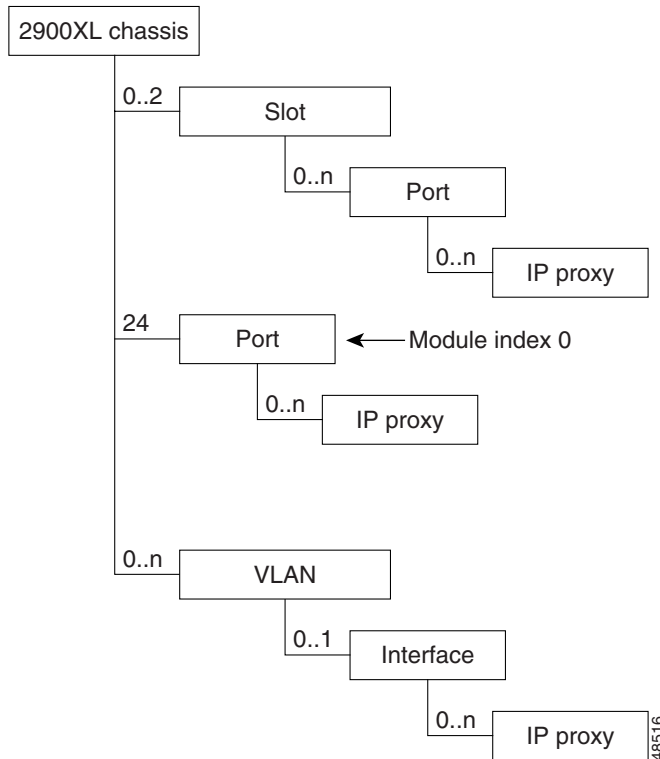

Discovery of Cisco Catalyst 5500 and 6509 Components

Cisco MGC Node Manager models slots, VLANs, and ports on Cisco Catalyst 5500 and 6509 series devices. During auto discovery, Cisco MGC Node Manager retrieves the tables shown in [Table 5-5](#).

Each entry in the moduleTable is modeled as a switch5500Slot object, and every entry in the portTable

Table 5-5 Catalyst 5500 Discovery Tables

Table	Description
CISCO-STACK-MIB.moduleTable	Defines all of the modules (slots) on the chassis
CISCO-STACK-MIB.portTable	Defines all of the ports on the chassis
CISCO-STACK-MIB.vlanTable	Defines all of the VLANs on the chassis
SNMPv2-MIB.ifTable	Defines all of the interfaces on the chassis

is modeled as a switch5500Port object. To correlate the information, the attribute portModuleIndex defines the slot on which the port is located, and the portIfIndex is used to correlate the portTable to its corresponding interface in the ifTable.

Each entry in the vlanTable is modeled as a switch5500VLAN object. The attribute vlanIfIndex associates each element in the VLAN table to its corresponding interface in the ifTable. The associated interface is shown as a child of its corresponding VLAN.

The SC0 and SL0 interfaces are modeled directly under the chassis object. In the MIB, one interface has a valid IP address while the other has an IP address of 0.0.0.0. While both interfaces are modeled, only the valid IP is shown.

The Catalyst 5500 subrack component is shown in [Figure 5-8](#).

Figure 5-8 Catalyst 5500 Chassis Discovery

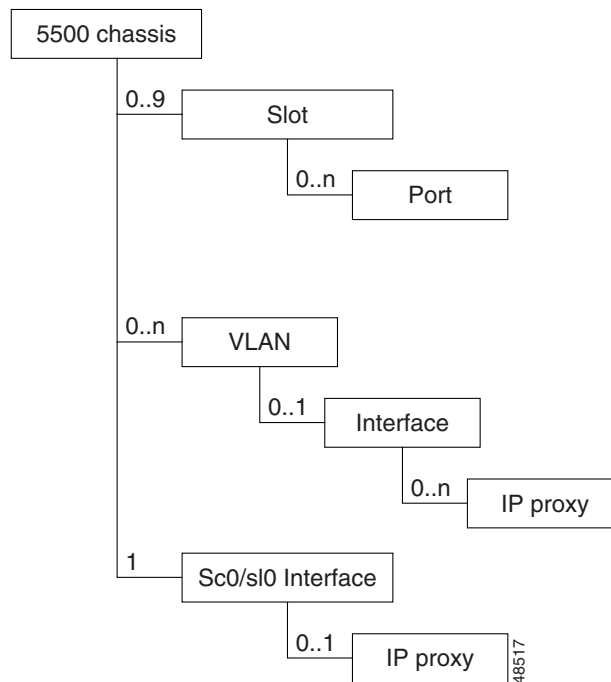

Keeping the Cisco MGC Node Manager Network Model Up To Date

Through periodic rediscovery of the components of each deployed device, Cisco MGC Node Manager ensures that its database and the Cisco MGC Node Manager network model are synchronized with the underlying network elements. The default interval at which automatic rediscovery occurs is every 6 hours, but you can change the interval, and you can manually invoke rediscovery when needed. These tasks are described in the [“Synchronizing the Cisco MGC Node Manager Model with Device Changes”](#) section on page 5-20.

If basic account information about a device (such as its password) changes, you can modify the information in the device Accounts dialog box. If the device is no longer in the network, you can delete it. This is described in the [“Modifying or Deleting Deployed Objects”](#) section on page 5-21.

SNMP Traps for Configuration Changes

All relevant management data in the Cisco MNM database is automatically updated on receipt of a modification trap from the various network elements in the Cisco MGC node.

**Note**

Configuration information, including modification traps, is collected only for the node devices, not for the BAMS or Cisco MGC.

The traps in [Table 5-6](#) are used to signal changes in the network elements.

Table 5-6 Network Element Configuration Traps

Network Element	Configuration Changed Trap
Cisco MGC host	POM: DynamicReconfiguration
LAN switch	coldStart, warmStart, configChange
Cisco SLT	reload, configChange

When Cisco MGC Node Manager receives a POM:DynamicReconfiguration trap from the active Cisco MGC host, it resynchronizes its view of the connectivity network with that of the device.

Synchronizing the Cisco MGC Node Manager Model with Device Changes

You can change the interval at which Cisco MGC Node Manager checks deployed devices for any changes to their components. You can also rediscover a device immediately when needed.

Auto-discovery frequency applies to all devices of the same type.

For SSH-enabled components (defined as the Security Policy at deployment or in the Accounts dialog box, Discovery uses SSH.

To Change the Automatic Rediscovery Interval

Use the following procedure to change the frequency of automatic rediscovery for a particular device type:

- Step 1** In the Map Viewer, right-click the desired object, and choose **States**. The States dialog box appears.
- Step 2** On the Polling tab, change the frequency for **Auto-Discovery**. The default is every 6 hours.



Note Setting very frequent discovery can place a heavy demand on system resources.

- Step 3** Click the Save tool or choose **File > Save**.
- Step 4** Close the dialog box.

When the device is rediscovered, if the Event Browser is open, it displays the message, “Discovery is now complete”. With each new discovery, any earlier discovery messages are cleared; only the most recent discovery message appears.

To Manually Rediscover a Device

Use the following procedure to rediscover a device on demand:

-
- Step 1** In the Map Viewer, select the object, and right-click.
- Step 2** Choose **States**. You see the States dialog box.
- Step 3** On the States tab, click **Rediscover**. You are asked if you want to rediscover the device.
- Step 4** Click **Yes**. Cisco MGC Node Manager rediscovers the device. During discovery, Current State is “discovering.” When the discovery is complete, Current State changes to Active (for the HSI server, BAMS, and Cisco MGC host) or Normal (for the Cisco SLT and LAN Switch).



Note If the Event Browser is open, it displays the message, “Discovery is now complete”, when discovery has been completed. With each new discovery, any earlier discovery messages are cleared; only the most recent discovery message appears.

- Step 5** Close the dialog box.
-

Modifying or Deleting Deployed Objects

Modify a deployed object when either of the following is changed:

- The device password
- SNMP community strings

If an object’s IP address changes, delete the object, and redeploy it. Also delete a deployed object when the device is removed from the network or when you want to redeploy the object.

Modifying a Deployed Object

You can change device login, password, and SNMP community strings in the Accounts dialog box. Use the following procedure to modify deployment information:

-
- Step 1** In the Map Viewer, right-click the device you want to modify, and choose **Accounts**. The Accounts dialog box appears.
- Step 2** Modify the information, as needed:
- Use the Accounts tab to change Host Login ID, Login Password, and Host Root Password.
 - Use the SNMP tab to change community strings
- Step 3** When you are done, choose **File > Save** or click the **Save** tool, and close the dialog box.

The new information is saved. When Cisco MGC Node Manager rediscovers the object at the next scheduled interval, this information will be used to discover the device components.



Note To immediately rediscover the device components, right-click the device, and choose **States**. On the **States** tab, click **Rediscover**. All components of the device are rediscovered.

Deleting a Deployed Object

You can delete a single object or multiple objects. You might delete an object if:

- The device has been removed from the network.
- There was something wrong in the seed file, but it did not cause deployment to fail.
- The device's IP address has changed.

In the last two cases, redeploy the device after deleting the object representing it.



Caution

Although you can delete the object that represents a component of a device, such as an interface or a disk partition, do not. Instead, let Cisco MNM rediscover the device. In rediscovery, removed components are deleted automatically.

Use the following procedure to delete one or more deployed objects:

-
- Step 1** In the Map Viewer, do one of the following:
- To delete a single object, right-click it.
 - To delete multiple objects, **Ctrl-click** to select noncontiguous objects or **Shift-click** to select a block of objects, and then right-click.
- Step 2** Choose **Deployment > Delete Objects**. The Deployment Wizard Summary window appears with the message “Ready to delete (n) object(s),” where *n* is the number of objects selected.
- Step 3** Click **Finish**.
- The selected object or group of objects is deleted. A message informs you that one or more objects have been deleted from the system.
-

Exporting Deployment Information to an Inventory or Seed File

You can export deployment information to an inventory file or a seed file. A seed file includes information similar to that shown in [Example 5-1 on page 5-6](#). An inventory file covers only the Cisco MGC node devices, but it includes detailed system information obtained during discovery. For each device, it captures the current:

- IP address
- Hardware type
- Operating system, host version, and software versions



Note

Inventory information for the BAMS is included if the BAMS has been configured to collect call detail records for a Cisco MGC host.

An inventory file might be used by software that tracks inventory data about the network. A seed file can be used to capture a snapshot of your network deployment at a particular time, to be used for later deployment or to replicate a deployed network.

An example of an inventory file is shown here:

Example 5-3 Example of Exported Inventory File

```

MGC (Name = MGC-1) {
    HOST (Name = Host-1, SysName = nssuvsc21, IpAddr = 10.10.10.71, HardwareModel =
    SUNW,UltraSPARC-Iii-Engine, HostId = 80d1bd49, HostVersion = 9.0(0.16), HostVendor =
    "Cisco Systems, Inc.", Switch_Type = Switched-VSC, OS_Version = Generic_105181-23,
    OS_Release = 5.6)
    2600 (Name = SLT, SysName = n2600a.cisco.com, IpAddr = 10.10.10.72, ChassisId =
    "JAB032101S4 (3076808945)", ChassisType = 89, ChassisVersion = 0x202, ROM_Sys_Version
    = "Cisco Internetwork Operating System Software IOS (tm) C2600 Software
    (C2600-IPSS7-M), Version 12.1(3)T, RELEASE SOFTWARE (fc1) Copyright (c) 1986-2000 by
    cisco Systems, Inc. Compiled Wed 19-Jul-00 19:49 by ccai", ROM_Monitor_Version = "
    System Bootstrap, Version 11.3(2)XA4, RELEASE SOFTWARE (fc1) Copyright (c) 1999 by
    cisco Systems, Inc. TAC:Home:SW:IOS:Specials for info ", Sys_Config_Name =
    flash:c2600-ipss7-mz.121-3.T.bin)
    5500 (Name = Switch-1, SysName = nssu-cat5500-1, IpAddr = 10.10.10.74,
    Chassis_Serial_No. = 9999999, ChassisModel = WS-C5509, ChassisType = 14,
    Sys_Booted_Image = bootflash:cat5000-sup3.5-5-4b.bin)
}

```

Table 5-7 shows the attributes exported for the various device types.

Table 5-7 Deployment Information Exported to an Inventory File

Attribute	Types	Description
name	All	Name of the object in Cisco MGC Node Manager
ip	All except Cisco MGC node and farm	IP address of the device
os	All except Cisco MGC node and farm	Operating system name and version
boot	Cisco SLT/LAN switch	Name of the OS boot image
hostID	Cisco MGC host/BAMS/HSI server	Solaris host ID
hostName	Cisco MGC host/BAMS/HSI server	Name of the host

Use the following procedure to export deployment information to an inventory file or a seed file:

- Step 1** From the Map Viewer screen, select the MGC-Node-View icon.
- Step 2** Right-click, and choose **Deployment > Deploy Network Seed File**.
You see the Deploy Network dialog box.
- Step 3** Click the **Advanced** tab.
- Step 4** In the Export section, for Filename enter a name for the file to be created.
- Step 5** Do one of the following:
 - To export the information as an inventory file, click **Export Inventory**.
 - To export the information as a seed file, click **Export Seed File**.

You see a message prompting for confirmation.

Step 6 Click **Yes**.

You see a message confirming the file creation.



Note By default, the file is saved in the <CEMF Root>/bin/.mgcControllerx.sysmgr folder. Specify the path if you want to save to a different location.

Step 7 Click **Close**.

Step 8 Close the Deploy Network dialog box.
