



# Managing Cisco IOS XR Software Packages

---

The Cisco IOS XR software comprises modular “packages” that provide boot and feature functionality. This chapter describes the concepts and tasks necessary to manage Cisco IOS XR software packages.

## Contents

This chapter contains the following sections:

- [Overview of Software Packages, page 5-1](#)
- [Selecting and Obtaining Software Packages, page 5-16](#)
- [Information About Package Management, page 5-18](#)
- [Package Management Procedures, page 5-22](#)
- [Configuration Examples for Managing Packages, page 5-37](#)

## Overview of Software Packages

This section provides the following information on software packages:

- [Available Packages, page 5-1](#)
- [Standard PIE Filenames and Version Numbers, page 5-11](#)
- [Software Maintenance Update PIE Filenames and Version Numbers, page 5-13](#)

## Available Packages

Cisco IOS XR software comprises modular “packages.” Each package contains the components to perform a specific set of router functions, such as routing, security, or line card support. The Cisco IOS XR Unicast Routing Core Bundle provides six packages for use on every router. Four optional packages provide additional features. These packages are described later in this chapter.

[Figure 5-1](#) shows the available Cisco IOS XR software packages. These packages are distributed in Package Installation Envelope (PIE) files. See the [“Where to Place Installable PIE Files”](#) section on [page 5-16](#) for information on obtaining PIE files.

Figure 5-1 Cisco IOS XR Software Packages

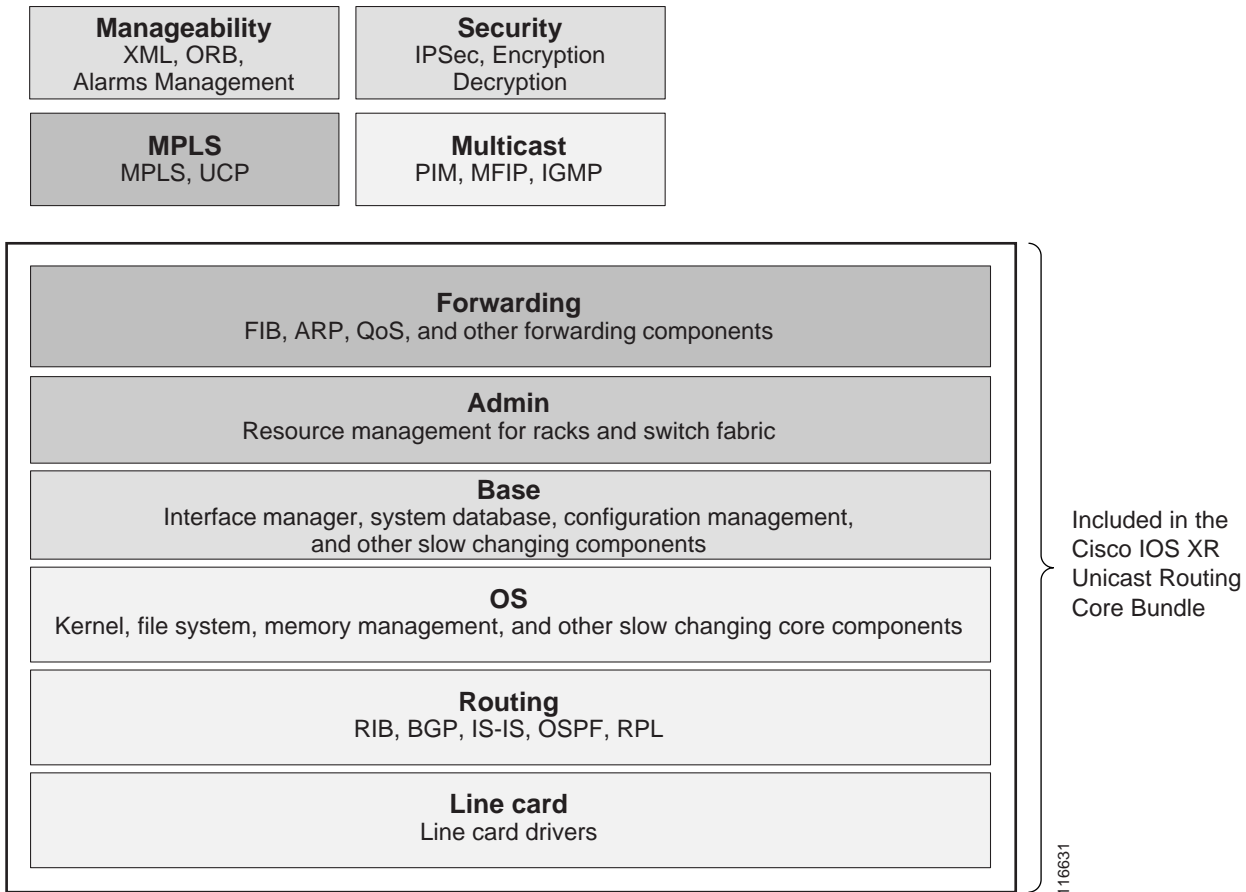

## Cisco IOS XR Unicast Routing Core Bundle

Table 5-1 describes the required core packages that are delivered in the Cisco IOS XR Unicast Routing Core Bundle.

**Table 5-1** Required Packages Included in the Cisco IOS XR Unicast Routing Core Bundle

Package Name	Features
OS Basic operating system	<ul style="list-style-type: none"> <li>• 1 GB flash</li> <li>• DOSFAT</li> <li>• File system support</li> <li>• Flash disk support</li> <li>• Initial system bring-up from disk0:</li> <li>• QNET</li> <li>• QNX flash file system</li> <li>• Spinning media support</li> <li>• System bring-up</li> <li>• System bring-up from disk1:</li> <li>• System bring-up from ROM Monitor (ROMMON) using TFTP</li> </ul>
Admin Basic software required to install packages and manage the router	<ul style="list-style-type: none"> <li>• Admin plane—logical router (LR) plane isolation</li> <li>• Admin plane support</li> <li>• Control Fast Ethernet (FE) support</li> <li>• Control Gigabit Ethernet (GE) support</li> <li>• dLRSC election</li> <li>• Designated shelf controller (DSC) election</li> <li>• Fabric card online insertion and removal (OIR)</li> <li>• Fabric manager</li> <li>• Fabric plane management</li> <li>• Fabric statistics</li> <li>• Fabric topology management</li> <li>• CRS-1 platform support</li> <li>• Cisco XR 12000 Series Router support for Cisco XR 12404, Cisco XR 12406, Cisco XR 12410, and Cisco XR 12416 routers</li> <li>• LR infrastructure</li> <li>• LR plane support</li> <li>• Management GE support</li> <li>• Owner LR support</li> </ul>

**Table 5-1** Required Packages Included in the Cisco IOS XR Unicast Routing Core Bundle

Package Name	Features
Base  Basic infrastructure needed to boot to the CLI prompt	<ul style="list-style-type: none"> <li>• AAA Services</li> <li>• BCDL</li> <li>• BGP TTL 255 Hack</li> <li>• Dependency checker</li> <li>• DLL upgrade</li> <li>• GSP</li> <li>• Hitless software upgrade or downgrade using PIE files</li> <li>• Interface manager</li> <li>• Maintain and display counters for each entry in the internal Forwarding Information Base (FIB)</li> <li>• Maintain and display internal FIB upon user request</li> <li>• MD5 or one-way encryption support</li> <li>• Netio</li> <li>• Netio—DLL Restart</li> <li>• Packet manager</li> <li>• Password management</li> <li>• PFI</li> <li>• QSM</li> <li>• Rate limiting router addressed and originated packets—hardcoded</li> <li>• Role-based authorization</li> <li>• Scoped restarts</li> <li>• Support for routing inbound packets using Layer 3 information</li> <li>• Support for routing inbound packets using Layer 4 information</li> <li>• Support forwarding to target route processor (RP) and distributed route processor (DRP)</li> <li>• SysDB—Hitless downgrade or upgrade</li> <li>• Syslog over IPv4 transport</li> <li>• Syslog over IPv6<sup>1</sup> transport</li> <li>• Syslog support</li> <li>• TACACS+ support</li> <li>• Version manager (including data translator)</li> </ul>

**Table 5-1** Required Packages Included in the Cisco IOS XR Unicast Routing Core Bundle

Package Name	Features
Forwarding	<ul style="list-style-type: none"> <li>• (X) access control lists (ACLs)</li> <li>• Quality of service (QoS) and class of service (CoS) using MQC</li> <li>• Queueing (ingress and egress)</li> <li>• Policing (ingress and egress)</li> <li>• Diagnostic and network management support</li> <li>• ARP</li> <li>• Class-based marking (ingress and egress) for discard class, multicast traffic, EXP, QoS group, v4 DSCP, and v4 precedence</li> <li>• CLNS services</li> <li>• dCEF support</li> <li>• DHCP relay</li> <li>• DNS client support</li> <li>• FTP client and FTP client support</li> <li>• High-level data link control (HDLC) (Cisco)</li> <li>• IPv4</li> <li>• IPv6<sup>1</sup> (excluding IPsec and mobility)</li> <li>• Layer 3 loopback, policing (dual-rate three-color policer and single-rate three-color policer), load balancing through CEF, and load balancing through CEF (IPv6<sup>1</sup> forwarding services)</li> <li>• MDRR support</li> <li>• NTP support with external source</li> <li>• PPP support</li> <li>• Random Early Detection (RED)—based on precedence</li> <li>• DSCP</li> <li>• EXP</li> <li>• Sockets Label Information Base (LIB) support</li> <li>• Telnet support</li> <li>• TFTP support</li> <li>• Trace route support</li> <li>• Weighted Random Early Detection (WRED)—based on bytes or packets or time</li> </ul>

**Table 5-1** Required Packages Included in the Cisco IOS XR Unicast Routing Core Bundle

Package Name	Features
Line Card	<ul style="list-style-type: none"> <li>• Alarms and (performance monitoring) PM</li> <li>• Automatic Protection Switching (APS) during line card (LC) failure</li> <li>• APS during LC OIR</li> <li>• APS and MSP GR-253</li> <li>• G-783 Annex A/G-841 (no Annex B)</li> <li>• Cisco IOS-like APS and MSP</li> <li>• Bellcore GR-253 (as applicable)</li> <li>• Dynamic mapping of queues to interfaces</li> <li>• Hierarchical QoS (on cards that support this)</li> <li>• ITU-T G.957 (as applicable)</li> <li>• Layer 1 loopback</li> <li>• Loopback support (for each subinterface and for each port)</li> <li>• OC-192</li> <li>• OC-48</li> <li>• Optical power monitoring</li> <li>• Pointer activity monitoring</li> <li>• SONET and Synchronous Digital Hierarchy (SDH) alarm recognition and processing</li> <li>• SONET and SDH header byte visibility and manipulation</li> <li>• SONET and SDH concatenated</li> <li>• Standards-compliant SONET and SDH interface</li> <li>• Stratum3 and G.813 clocking</li> <li>• Maximum number of egress (CoS) queues as supported by hardware</li> <li>• Maximum number of ingress queues as supported by the hardware</li> <li>• Maximum number of interfaces as supported by hardware</li> <li>• Maximum prefix table size as supported by hardware</li> <li>• Synchronization: local (internal) or loop timed (recovered from network); Stratum 3 (4.6 pmm) clock accuracy</li> </ul>

**Table 5-1** Required Packages Included in the Cisco IOS XR Unicast Routing Core Bundle

Package Name	Features
Routing Routing protocols (BGP, OSPF, and IS-IS), RIB, and routing policy engine	<ul style="list-style-type: none"> <li>• MP-BGP v4</li> <li>• OSPFv2 and OSPFv3</li> <li>• IS-IS</li> <li>• Static routes</li> <li>• Route policy language (RPL)</li> <li>• BTSH</li> <li>• Conditional route injection (conditional advertisement)</li> <li>• Exponential backoff shortest path first (SPF) algorithm support</li> <li>• Extended community</li> <li>• Filter prefixes on a per-peer basis for inbound and outbound prefix advertisement</li> <li>• Graceful restart with NSF (Cisco implementation and IS-IS)</li> <li>• MD5 authentication</li> <li>• MPLS TE support—intra-area</li> <li>• Multipath support for eBGP</li> <li>• Multiple RIB table support for AFI and SAFI</li> <li>• Name-based community set</li> <li>• Next-hop propagation</li> <li>• Prioritized RIB update</li> <li>• RIB standby capable</li> <li>• RIB support redistribution</li> <li>• Route dampening</li> <li>• Route redistribution (IS-IS and OSPFv3)</li> <li>• Route map</li> <li>• Show advertised routes</li> </ul>

1. IPv6 is not supported on the Cisco XR 12000 Series Router.

## Optional Individual Packages

Table 5-2 describes the optional packages that can be activated individually.

**Table 5-2**      *Optional Packages*

Package Name	Features
Multicast	<ul style="list-style-type: none"> <li>• Auto-RP</li> <li>• Bidirectional Protocol Independent Multicast (PIM)</li> <li>• Dynamic registration using Internet Group Management Protocol (IGMP)</li> <li>• Explicit tracking of hosts, groups, and channels for IGMPv3</li> <li>• MBGP</li> <li>• MSDP</li> <li>• Multicast NSF</li> <li>• Multicast Reverse Path Forwarding (RPF)—loose mode</li> <li>• Out-of-resource handling</li> <li>• PIM-SM</li> <li>• PIM-SSM</li> <li>• Source Specific Multicast with IGMP v3</li> </ul>

Table 5-2 Optional Packages (continued)

Package Name	Features
Multiprotocol Label Switching (MPLS)	<ul style="list-style-type: none"> <li>• MPLS forwarding and load balancing</li> <li>• MPLS traffic engineering (MPLS TE)</li> <li>• Label distribution protocol (LDP) <ul style="list-style-type: none"> <li>– LDP core (RFC 3036) (including link and targeted neighbors)</li> <li>– LDP graceful restart (draft-ietf-mpls-ldp-graceful-restart02.txt)</li> <li>– LDP high availability (HA) (restart automatic switchover)</li> <li>– LDP MIBs (draft-ietf-mpls-ldp0mib-08.txt)</li> <li>– LDP support for Layer 3 load balancing</li> <li>– LDP support on Packet-over-SONET (PoS) interfaces</li> </ul> </li> <li>• Resource Reservation Protocol (RSVP) <ul style="list-style-type: none"> <li>– RSVP authentication, authorization, and accounting (AAA) CLI</li> <li>– RSVP core</li> <li>– RSVP extensions for OUNI</li> <li>– RSVP graceful restart and hellos</li> <li>– RSVP HA—nonstop forwarding (NSF) and hitless software upgrade</li> <li>– RSVP refresh reduction</li> </ul> </li> <li>• UNI <ul style="list-style-type: none"> <li>– UNI-C AAA CLI</li> <li>– UNI-C core</li> <li>– UNI-C HA—NSF and hitless software upgrade</li> <li>– UNI-C hierarchical SONET alarms suppression</li> <li>– UNI-C line protocol state control</li> <li>– UNI-C local path restoration</li> <li>– UNI-C node recovery support</li> </ul> </li> <li>• LMP—static configuration</li> <li>• Fast reroute (FRR) with link, node, and bandwidth protection</li> <li>• XML schema support, configuration, and operation</li> </ul>

Table 5-2 Optional Packages (continued)

Package Name	Features
Manageability	<ul style="list-style-type: none"> <li>• Alarms management—configuration, operation, and correlation support</li> <li>• Configuration editor and manager</li> <li>• Accounting and statistics management</li> <li>• Performance management</li> <li>• Border Gateway Protocol (BGP) IPv6<sup>1</sup></li> <li>• Fault manager</li> <li>• Network Time Protocol (NTP) configuration and operation</li> <li>• Control point and network management—generic requirements</li> <li>• Terminal services enhancements</li> <li>• Enhanced command-line interface (CLI)</li> <li>• Extensible markup language (XML) interface and schemas</li> <li>• Craft Works Interface (CWI)</li> <li>• Common Object Request Broker Architecture (CORBA) support</li> <li>• Simple Network Management Protocol (SNMP) v1, v2c, and v3 support</li> <li>• MIB support. For a complete list of supported MIBs, go to the following link: <a href="http://www.cisco.com/public/sw-center/netmgmt/cmtk/mibs.shtml">http://www.cisco.com/public/sw-center/netmgmt/cmtk/mibs.shtml</a></li> </ul>
Security	<ul style="list-style-type: none"> <li>• Client and server support</li> <li>• Secure socket layer (SSL)</li> <li>• Control packet policing</li> <li>• IPSec</li> <li>• Client and server support (Secure Shell [SSH] and SFTP)</li> <li>• Enhanced password security</li> <li>• IPv6<sup>1</sup> (SSH and SFTP)</li> <li>• MD5</li> <li>• PKI</li> <li>• Random number generator</li> <li>• Selective packet discard</li> <li>• SHTTP support</li> <li>• Software authentication</li> <li>• SSHv1 and SSHv2 support</li> <li>• v3 and TLSv1 support</li> </ul>

1. IPv6 is not supported on the Cisco XR 12000 Series Router.

## Package Installation Envelope Files

PIE files are nonbootable files that can be used to upgrade or add software packages to the router. A PIE file may contain a single package or a set of packages (called a composite package). Because the files are nonbootable, they must be installed and activated on a running router. PIE files have a .pie extension. When a PIE file contains software for a specific bug fix, it is called a Software Maintenance Update (SMU).

## Standard PIE Filenames and Version Numbers

Standard PIE filenames have two formats: one for composite-package PIEs and one for single-package PIEs. A composite-package file is a PIE file that contains multiple packages. The format for a composite-package filename on Cisco CRS-1s is:



Note

---

Hyphens in the composite-package filename are part of the filename, as shown following list.

---

*comp-platform-composite\_name.pie-major.minor.maintenance*

The format for a composite-package filename on Cisco XR 12000 Series Routers is:

*platform-composite\_name.pie-major.minor.maintenance*

The “comp” prefix indicates that the file is a composite of multiple packages.

The format for single-package PIEs on Cisco CRS-1s is:

*platform-package\_type.-p.pie-major.minor.maintenance*

The format for single-package PIEs on Cisco XR 12000 Series Routers is:

*platform-package\_type.pie-major.minor.maintenance*

The filename components for all of the packages are described in [Table 5-3](#).



Note

---

For Cisco XR 12000 Series Routers, single-package PIEs actually contain separate PIE files for the PRP and line cards. Although the Cisco XR 12000 Series Router single-package PIEs contain two PIEs, they are called single-package PIEs because the enclosed PIEs provide the features for only one feature package.

---

**Table 5-3 Composite- and Single-Package Filename Components**

Component	Description
<i>platform</i>	Identifies the platform for which the software package is designed. <ul style="list-style-type: none"> <li>• For packages designed for CRS-1 routers, the platform designation is “hfr.”</li> <li>• For packages designed for Cisco XR 12000 Series Router, the platform designation is “c12k.”</li> </ul>
<i>composite_name</i>	Identifies a specific composite package. <ul style="list-style-type: none"> <li>• The only composite PIE file at this time is named “mini” and includes all packages described in the <a href="#">“Cisco IOS XR Unicast Routing Core Bundle”</a> section on page 5-3.</li> </ul>
<i>package_type</i>	Identifies the type of package the file supports ( <i>package_type</i> applies only to single-package PIEs). Package types include: <ul style="list-style-type: none"> <li>• fwdg for the Forwarding package</li> <li>• lc for the Line Card package</li> <li>• mcast for the Multicast package</li> <li>• mgb1 for the Manageability package</li> <li>• mpls for the MPLS package</li> <li>• k9sec for the Security package</li> <li>• rout for the Routing package</li> </ul>
<i>major</i>	Identifies the major release of this package. <ul style="list-style-type: none"> <li>• A major release occurs when there is a major architectural change to the product (for example, a major new capability is introduced).</li> <li>• All packages operating on the router must be at the same major release level.</li> <li>• A major release is the least frequent release and may require a router reboot.</li> </ul>

Table 5-3 Composite- and Single-Package Filename Components (continued)

Component	Description
<i>minor</i>	Identifies the minor release of this package. <ul style="list-style-type: none"> <li>• A minor release contains one or more of the following:               <ul style="list-style-type: none"> <li>– New features</li> <li>– Bug fixes</li> </ul> </li> <li>• The minor release version does not have to be identical for all software packages operating on the router, but the operating packages must be certified by Cisco as compatible with each other.</li> <li>• A minor release may require a router reboot.</li> </ul>
<i>maintenance</i>	Identifies the maintenance release of this package. <ul style="list-style-type: none"> <li>• A maintenance release contains a collection of bug fixes for a package.</li> <li>• The maintenance release version does not have to be identical for all software packages operating on the router, but the major and minor versions of the maintenance release must match those of the package being updated.</li> <li>• A maintenance release does not usually require a router reboot.</li> </ul>

## Software Maintenance Update PIE Filenames and Version Numbers

An SMU is a PIE file that contains fixes for a specific defect. A composite SMU is a PIE file that contains SMUs for more than one package. SMUs are installed using the same procedures as other PIE files. SMUs are created to respond to immediate issues and do not include new features. Typically, SMUs do not have a large impact on router operations. SMU versions are synchronized to the package major, minor, and maintenance versions they upgrade.

SMUs are not an alternative to maintenance releases. They provide quick resolution of immediate issues. All bugs fixed by SMUs are integrated into the maintenance releases. The format for a single-package SMU filename is:

*platform-package\_type-major.minor.maintenance.ddts.pie*

The format for a composite-package SMU filename is:

*comp-platform-composite\_name.ddts.pie*

The “comp” prefix indicates that the file is a composite file containing multiple updates. The other filename components are described in [Table 5-4](#).

**Table 5-4** SMU Single- and Composite-Package Filename Components

Component	Description
<i>platform</i>	Identifies the platform for which the software package is designed. <ul style="list-style-type: none"> <li>For packages designed for CRS-1 routers, the platform designation is either “hfr” or “CRS-1.”</li> <li>For packages designed for Cisco XR 12000 Series Router, the platform designation is “c12k.”</li> </ul>
<i>composite_name</i>	Identifies a specific composite package. <ul style="list-style-type: none"> <li>The composite name is a name or number that is unique to the SMU.</li> </ul>
<i>ddts</i>	Identifies a Distributed Defect Tracking System (DDTS) number that describes the problem this SMU addresses. <p><b>Note</b> DDTS is the method used to track known bugs and the resolutions or workarounds for those issues.</p>
<i>package_type</i>	Identifies the type of package the file supports (package_type applies only to single-package PIEs). Package types include: <ul style="list-style-type: none"> <li>fwdg for the Forwarding package</li> <li>lc for the Line Card package</li> <li>mcast for the Multicast package</li> <li>mgbl for the Manageability package</li> <li>mpls for the MPLS package</li> <li>k9sec for the Security package</li> <li>rout for the Routing package</li> </ul>

**Table 5-4** *SMU Single- and Composite-Package Filename Components (continued)*

Component	Description
<i>major</i>	<p>Identifies the major release of this package.</p> <ul style="list-style-type: none"> <li>• A major release occurs when there is a major architectural change to the product (for example, a major new capability is introduced).</li> <li>• All packages operating on the router must be at the same major release level.</li> <li>• A major release is the least frequent release and may require a router reboot.</li> </ul>
<i>minor</i>	<p>Identifies the minor release of this package.</p> <ul style="list-style-type: none"> <li>• A minor release contains one or more of the following: <ul style="list-style-type: none"> <li>– New features</li> <li>– Bug fixes</li> </ul> </li> <li>• The minor release version does not have to be identical for all software packages operating on the router, but the operating packages must be certified by Cisco as compatible with each other.</li> <li>• A minor release may require a router reboot.</li> </ul>
<i>maintenance</i>	<p>Identifies the maintenance release of this package.</p> <ul style="list-style-type: none"> <li>• A maintenance release contains a collection of bug fixes for a package.</li> <li>• The maintenance release version does not have to be identical for all software packages operating on the router, but the major and minor versions of the maintenance release must match the those of the package being updated.</li> <li>• A maintenance release does not usually require a router reboot.</li> </ul>

In the following example, the SMU for the base package version 2.0.0 fixes DDTS CSCec98765:

SMU	SMU Filename
base-2.0.0.CSCec98765-1.0.0	hfr-base-2.0.0.CSCec98765.pie

In the following example, the SMU comp-001.CSCec98766 provides changes to multiple packages, as specified in DDTS CSCec98766:

SMU	SMU Filename
comp-001.CSCec98766	comp-hfr-001.CSCec98766.pie

**Note**

The composite name usually is “001,” which means the SMU is the first SMU for that DDTS. In rare cases in which the same DDTS requires multiple composite SMUs, a second composite version number is released as “002.” In the previous example, a second composite SMU “comp-002.CSCec98766” would be created for DDTS CSCec98766.

## Selecting and Obtaining Software Packages

The following sections provide details on the information available to help you select and obtain software packages:

- [“Obtaining Cisco IOS XR Software and Version Information from Cisco”](#)
- [“Where to Place Installable PIE Files”](#)

## Obtaining Cisco IOS XR Software and Version Information from Cisco

To obtain Cisco IOS XR software and version information, use the Cisco IOS XR Software Selector tool at the following website:

<http://www.cisco.com/cgi-bin/Software/IOXPlanner/planner-tool/ioxplanner.cgi?>

The following packages can be downloaded and installed without interrupting the router:

- Cisco IOS XR Unicast Routing Core Bundle
- Cisco IOS XR Unicast Routing Package
- Cisco IOS XR MPLS Package
- Cisco IOS XR Manageability Package
- Cisco IOS XR Multicast Package
- Cisco IOS XR Security Package

**Note**

The Cisco IOS XR IP/MPLS Core Software and the Cisco IOS XR IP/MPLS Core Software 3DES package must be installed from ROM Monitor, and the installation process does interrupt router operation. For more information on installing these software packages from ROM Monitor, see [Appendix A, “Router Recovery and Management with ROM Monitor.”](#)

The Cisco IOS XR Software Selector tool allows you to browse for your software upgrade from a single interface. You can display and select software by package name, release, and platform. The tool also includes XML schemas. Choosing a platform, release, or software feature automatically limits the choices based on your selection, until you arrive at your preferred software.

## Where to Place Installable PIE Files

After you download files, those files must be placed in a location that is accessible for router upgrades. PIE files can be installed from a removable flash disk or a TFTP, an FTP, or an rcp file server (see [Figure 5-2](#)).

Figure 5-2 Where to Locate and Store PIE Installation Files

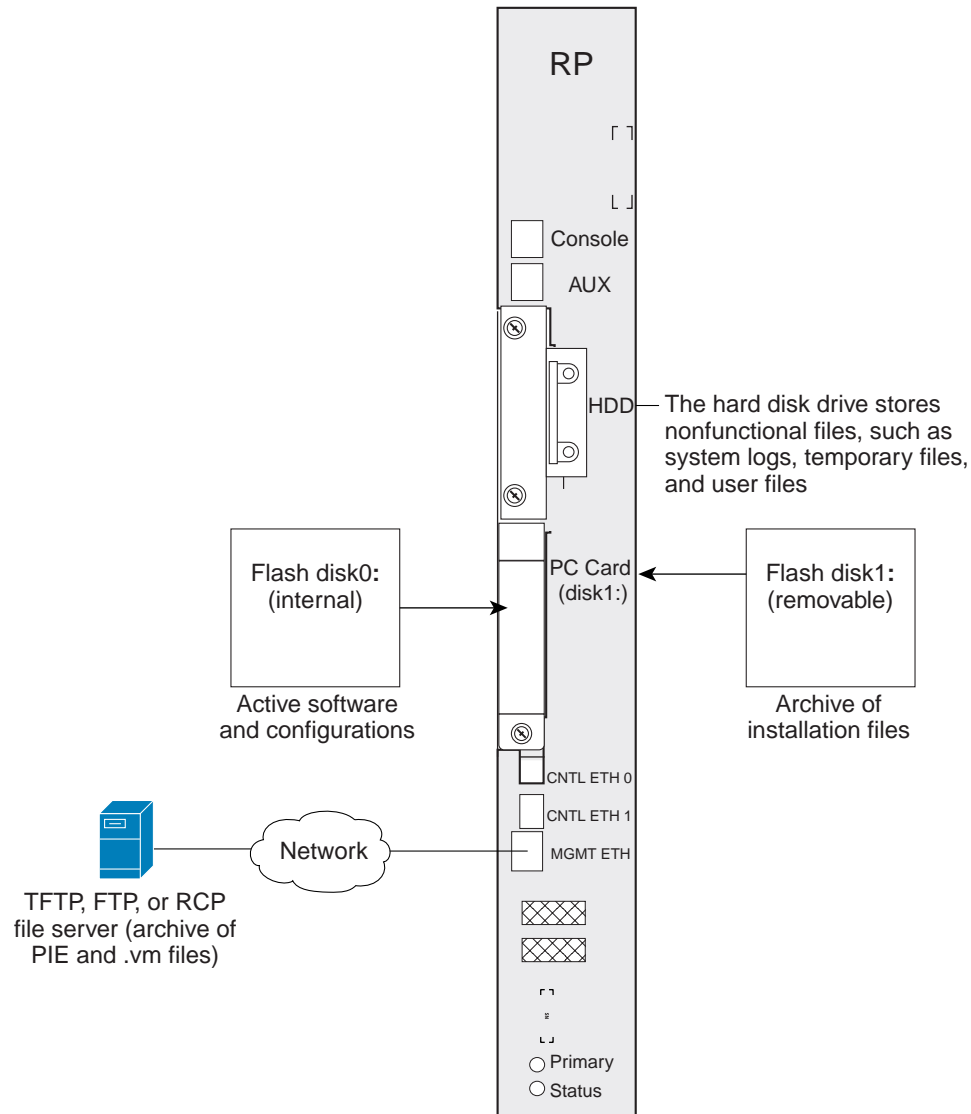

116548

**Note**

Files with the .vm extension are bootable installation files used only to replace all current Cisco IOS XR software. These files are installed from ROMMON and cause significant router downtime. We recommend installing or upgrading software packages using only PIE files, as described in this document. See [Appendix A, “Router Recovery and Management with ROM Monitor”](#) for information.

## Flash disk1: Archive of Installation PIE Files

Flash disk 1 (disk1:) is optional on Cisco CRS-1s and on Cisco XR 12000 Series Routers. When it is installed, flash disk 1 can be used to store PIE files, which can then be used to add new software to flash disk 0 (disk0:).

See the [“Obtaining Cisco IOS XR Software and Version Information from Cisco”](#) section on page 5-16 for information on obtaining a list of available PIE files.

**Note**

Flash disk 0 (disk0:) is required and used by the system, and disk0: should never be manipulated by the user. In addition, the hard disk is used to store system files, such as logs and user files. It should also not be used to store installation PIE files.

## Network Server: Downloading Updated PIE Files

Installable PIE software packages can also be downloaded from a TFTP, an FTP, or an rcp server to the archive on disk1:. Consult your system administrator for the location and availability of your network server. For information on the supported download protocols and command syntax to copy or install packages, see the [“Upgrading, Downgrading, and Installing Packages” section on page 5-26](#).

# Information About Package Management

This section describes the following concepts for managing Cisco IOS XR software packages:

- [Overview of Package Management, page 5-18](#)
- [Upgrading Packages, page 5-20](#)
- [Downgrading Packages, page 5-20](#)
- [Impact of Package Version Changes, page 5-21](#)
- [Impact of Package Activation and Deactivation, page 5-21](#)
- [Controlling install Command Operation, page 5-26](#)
- [Activation and Deactivation Prerequisites, page 5-22](#)

## Overview of Package Management

Package management processes include the following:

- Viewing which packages and package versions are in use
- Adding or removing optional packages
- Upgrading or downgrading installed packages
- Removing packages that are no longer in use
- Rolling back the selected package set to a previous package set

The general procedure for adding optional packages, upgrading packages, or downgrading packages on the router is as follows:

1. Copy the PIE file to the router.
2. Add the package to the router.
3. Activate the package on the router.
4. Commit the current set of packages.

[Figure 5-3](#) illustrates key steps in the package management process.

Figure 5-3 Process to Add, Activate, and Commit Cisco IOS XR Software Packages

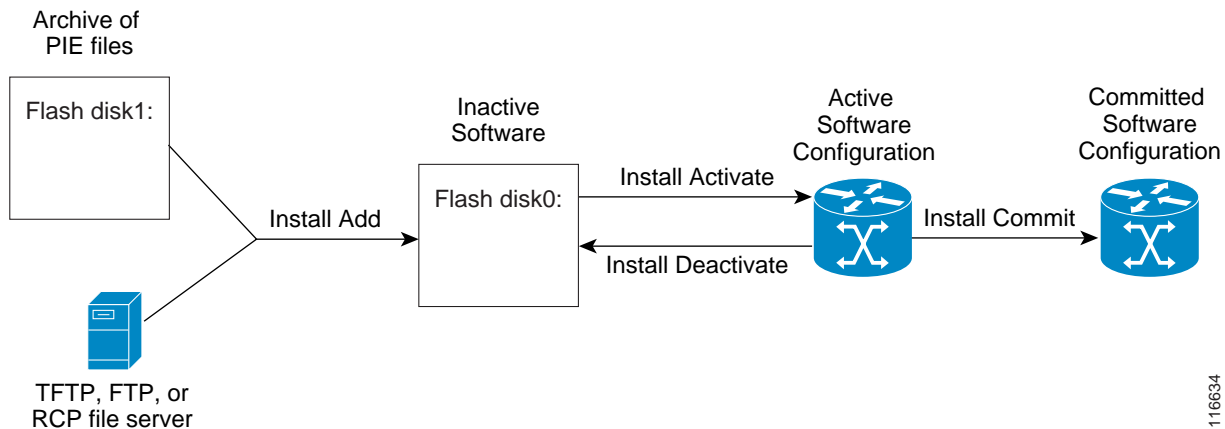

When you are adding an optional package, upgrading a package, or downgrading a package and the package version you want to use is not available on the router, you must copy the appropriate PIE file to the router. You can copy the files to the router by inserting a flash disk with the appropriate files in the slot for flash disk1: , or you can copy files to the router from a file server. Although you can transfer PIE files to flash disk1: or flash disk0:, the recommended approach is to store PIE files on flash disk1:. Flash disk1: serves as the archive for PIE files that are no longer in use or have yet to be added. Flash disk0: serves as the storage location for all files that are ready for activation.



## Tip

Before copying PIE files to the router, check to see if the required PIE files are on flash disk1:.

After the required PIE file is on the router, the next step is to use the **install add** command to unpack the PIE file and move the package software to a storage device, which is usually flash disk0:. On routers with primary and standby RPs, the package is also added to the standby RP so that the standby RP is prepared to take over if the primary RP fails. The add process produces package software that is ready for activation.

When you activate a software package with the **install activate** command, the router starts using the package version you have activated. If you are activating an optional package that has not been previously activated, the package is activated on all cards. If you are activating a newer (upgrade) or an older (downgrade) version of a previously activated package, you can choose to activate the package on all cards or on specific cards. When a package is activated during an upgrade or a downgrade, the previously active package version is deactivated.

The final step in adding, upgrading, or downgrading a package is to commit the current set of packages to the router configuration. When a router is reloaded, it loads the last committed set of packages. If different packages have been activated and not committed, those packages are not loaded. To ensure that recently activated packages become part of the committed package set, enter the **install commit** command.

Although the term *commit* sounds final, the Cisco IOS XR software provides the flexibility to roll back the selected package set to previously saved package sets. Each time a package is activated or deactivated, a rollback point is created that defines the package set that is active after the package activation or deactivation. The software also creates a rollback point for the last committed package set. If you find that you prefer a previous package set over the currently active package set, you can use the **install rollback** command to make a previously active package set active again.

## Upgrading Packages

To upgrade a package that is currently active on the router, activate a newer version of the same package for one or more cards for which an older version is already active (see [Figure 5-4](#)). The older version of the same software package is deactivated automatically. These actions are permitted only after the package compatibility checks and API version compatibility checks have passed.

Deactivated packages are not removed from the storage device. To delete an inactive package from the disk, enter the **install remove** command. See the “[Removing Inactive Packages from the Router](#)” section on page 5-37 for more information.



### Caution

Upgrading or downgrading a software package can cause a process to restart or a new process to start. Use the **test** option to preview the impact of the package activation.

**Figure 5-4** Example of a Maintenance Release Package Upgrade

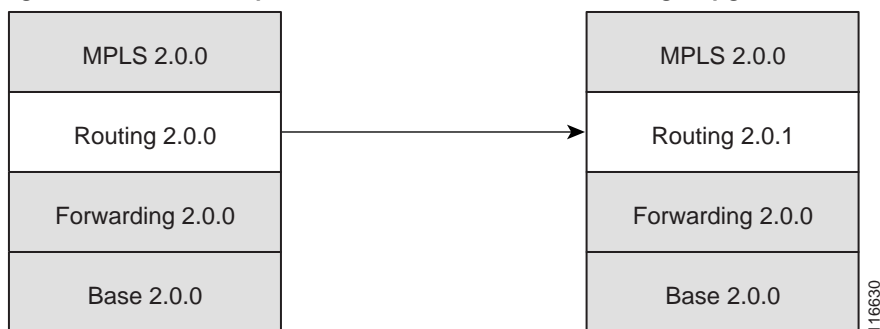

## Downgrading Packages

To downgrade a software package, activate an older version on one or more cards for which that package is already active. The newer version of the same software package is deactivated automatically. These actions are performed only after the package compatibility checks and API version compatibility checks have passed.

Deactivated packages are not removed from the storage device. To delete an inactive package from the disk, enter the **install remove** command. See the “[Removing Inactive Packages from the Router](#)” section on page 5-37 for more information.

## Impact of Package Version Changes

Each package upgrade has a different impact on the operation of the router, depending on the type of package and whether the upgrade is for a major, minor, or maintenance release. The following resources can provide more information on the impact of a package version change:

- See the “[Standard PIE Filenames and Version Numbers](#)” section on page 5-11 for more information on the typical impact for major, minor, and maintenance releases.
- For specific information regarding the impact of an upgrade, consult the release notes for the package release, and test the impact of the package activation by adding the **test** option to the **install activate** command.
- The IOS XR Software Selector tool also contains information on package version compatibility. See the “[Selecting and Obtaining Software Packages](#)” section on page 5-16 for information regarding online compatibility resources.

## Impact of Package Activation and Deactivation

Activation or deactivation of a package can have an immediate impact on the system. The system can be affected in the following ways:

- When a new package is activated, any new CLI commands for the package are added to the system. The router need not be restarted or reloaded.
- When a package is deactivated, the commands associated with the features being deactivated are removed from the system and are no longer available to the user.
- During a software package deactivation, upgrade, or downgrade, any incompatible configurations are removed from the running configuration and saved to a file. Incompatible configurations are those configurations that are not supported by the new version of the software package.



### Note

---

You must address any issues that result from the removed configuration and reapply the configuration, if necessary.

---

- New processes may be started.
- Running processes may be stopped or restarted.
- All processes in the cards may be restarted. Restarting processes in the cards is equivalent to a soft reset.
- The cards may reload.
- No impact: no processes in the card are affected.



### Tip

---

When activating and deactivating packages, use the **test** option to test the effects of a command without impacting the running system. After the activation or deactivation process completes, enter the **show install log** command to display the process results.

---

## Activation and Deactivation Prerequisites

The following prerequisites must be met for a package to be activated or deactivated.

- All cards should be installed and operating properly. For example, you should not activate or deactivate packages while cards are booting, while cards are being upgraded or replaced, or when you anticipate an automatic switchover activity.
- Initial activation of any package must always be performed for the default set of supported card types.
- If a ROM Monitor upgrade is required for the software package, the upgrade must be completed before the package is activated. For ROM Monitor upgrade information and procedures, see [Appendix B, “Upgrading and Downgrading ROM Monitor Software on Cisco CRS-1 Routers.”](#)
- Although more than one version of a software package can be added to a storage device, only one version of a package can be active for any card.
- The package must be compatible with the card for which it is being activated.
- Some packages require the activation or deactivation of other packages.
- The package being activated must be compatible with the current active software set.
- While a software package is being activated, other requests are not allowed to execute on the system. Each installation request is assigned a requestID, which can be used later to review the events. Package activation is complete when the following message is displayed:

```
Install 1: Activation operation successful.
```

Activation is performed only after the package compatibility checks and API version compatibility checks have passed. If a conflict is found, an on-screen error message is displayed.

## Package Management Procedures

Review the concepts in the [“Information About Package Management”](#) section on [page 5-18](#) before performing the following tasks. The following sections describe package management tasks:

- [Displaying the Active Packages for All Cards, page 5-23](#)
- [Displaying the Active Packages for a Single Card, page 5-25](#)
- [Displaying the Committed Package Versions for Each Card, page 5-25](#)
- [Upgrading, Downgrading, and Installing Packages, page 5-26](#)
- [Rolling Back to the Last Committed Package Set, page 5-34](#)
- [Displaying Noncommitted Rollback Points, page 5-34](#)
- [Rolling Back to a Noncommitted Rollback Point, page 5-35](#)
- [Committing the Active Package Set, page 5-36](#)
- [Deactivating a Package, page 5-37](#)
- [Removing Inactive Packages from the Router, page 5-37](#)
- [Activating and Testing a Package on the Router: Example, page 5-38](#)

## Displaying the Active Packages for All Cards

In the following example, the active packages for all cards in a Cisco CRS-1 system are shown:

```
RP/0/RP1/CPU0:Router# show install active

Node 0/1/SP [SP]
  Boot Image: /disk0/hfr-os-mbi-3.2.00/sp/mbihfr-sp.vm
  Active Packages:
    disk0:comp-hfr-mini-3.2.00

Node 0/1/CPU0 [LC]
  Boot Image: /disk0/hfr-os-mbi-3.2.00/lc/mbihfr-lc.vm
  Active Packages:
    disk0:hfr-mcast-3.2.00
    disk0:hfr-mpls-3.2.00
    disk0:comp-hfr-mini-3.2.00

Node 0/RP1/CPU0 [RP]
  Boot Image: /disk0/hfr-os-mbi-3.2.00/mbihfr-rp.vm
  Active Packages:
    disk0:hfr-mgbl-3.2.00
    disk0:hfr-mcast-3.2.00
    disk0:hfr-mpls-3.2.00
    disk0:hfr-k9sec-3.2.00
    disk0:comp-hfr-mini-3.2.00

Node 0/SM0/SP [SP]
  Boot Image: /disk0/hfr-os-mbi-3.2.00/sp/mbihfr-sp.vm
  Active Packages:
    disk0:comp-hfr-mini-3.2.00

Node 0/SM1/SP [SP]
  Boot Image: /disk0/hfr-os-mbi-3.2.00/sp/mbihfr-sp.vm
  Active Packages:
    disk0:comp-hfr-mini-3.2.00
```

In the preceding example, the active packages for each node are on disk0:, and for all nodes, the composite package comp-hfr-mini-3.2.00 is active. Where additional packages are shown, those are optional packages that have been added after the initial loading of the Cisco IOS XR Unicast Routing Core Bundle.

The **show install active detail** command displays all information that appears without the **detail** option, and it displays the active packages within each composite package. In the next example, the active packages for all cards in a Cisco XR 12000 Series Router are shown using the **detail** option:

```
RP/0/0/CPU0:router# show install active detail

Node 0/0/CPU0 [RP]
  Boot Image: /disk0/c12k-rp-os-mbi-3.2.00/mbiprp-rp.vm
  Active Packages:
    disk0:c12k-mini-3.2.00
    disk0:c12k-rp-rout-3.2.00
    disk0:c12k-rp-lc-3.2.00
    disk0:c12k-rp-fwg-3.2.00
    disk0:c12k-rp-admin-3.2.00
    disk0:c12k-rp-base-3.2.00
    disk0:c12k-rp-os-mbi-3.2.00
```

```
Node 0/3/CPU0 [LC(E3-OC3-POS-8)]
  Boot Image: /disk0/c12k-lc-os-mpi-3.2.00/gsr/ucode/mpi12000-lc.unicode
  Active Packages:
    disk0:c12k-mini-3.2.00
    disk0:c12k-lc-lc-3.2.00
    disk0:c12k-lc-fwdg-3.2.00
    disk0:c12k-lc-admin-3.2.00
    disk0:c12k-lc-base-3.2.00
    disk0:c12k-lc-os-mpi-3.2.00

Node 0/4/CPU0 [LC(E3-GE-4)]
  Boot Image: /disk0/c12k-lc-os-mpi-3.2.00/gsr/ucode/mpi12000-lc.unicode
  Active Packages:
    disk0:c12k-mini-3.2.00
    disk0:c12k-lc-lc-3.2.00
    disk0:c12k-lc-fwdg-3.2.00
    disk0:c12k-lc-admin-3.2.00
    disk0:c12k-lc-base-3.2.00
    disk0:c12k-lc-os-mpi-3.2.00

Node 0/5/CPU0 [LC(E3-GE-4)]
  Boot Image: /disk0/c12k-lc-os-mpi-3.2.00/gsr/ucode/mpi12000-lc.unicode
  Active Packages:
    disk0:c12k-mini-3.2.00
    disk0:c12k-lc-lc-3.2.00
    disk0:c12k-lc-fwdg-3.2.00
    disk0:c12k-lc-admin-3.2.00
    disk0:c12k-lc-base-3.2.00
    disk0:c12k-lc-os-mpi-3.2.00

Node 0/6/CPU0 [LC(E3-OC48-POS)]
  Boot Image: /disk0/c12k-lc-os-mpi-3.2.00/gsr/ucode/mpi12000-lc.unicode
  Active Packages:
    disk0:c12k-mini-3.2.00
    disk0:c12k-lc-lc-3.2.00
    disk0:c12k-lc-fwdg-3.2.00
    disk0:c12k-lc-admin-3.2.00
    disk0:c12k-lc-base-3.2.00
    disk0:c12k-lc-os-mpi-3.2.00

Node 0/7/CPU0 [LC(E3-GE-4)]
  Boot Image: /disk0/c12k-lc-os-mpi-3.2.00/gsr/ucode/mpi12000-lc.unicode
  Active Packages:
    disk0:c12k-mini-3.2.00
    disk0:c12k-lc-lc-3.2.00
    disk0:c12k-lc-fwdg-3.2.00
    disk0:c12k-lc-admin-3.2.00
    disk0:c12k-lc-base-3.2.00
    disk0:c12k-lc-os-mpi-3.2.00

Node 0/8/CPU0 [LC(E3-OC12-POS-4)]
  Boot Image: /disk0/c12k-lc-os-mpi-3.2.00/gsr/ucode/mpi12000-lc.unicode
  Active Packages:
    disk0:c12k-mini-3.2.00
    disk0:c12k-lc-lc-3.2.00
    disk0:c12k-lc-fwdg-3.2.00
    disk0:c12k-lc-admin-3.2.00
    disk0:c12k-lc-base-3.2.00
    disk0:c12k-lc-os-mpi-3.2.00
```

## Displaying the Active Packages for a Single Card

To display the active packages for a single card, enter the **show install active** command with the **location** option.

The following example shows the active packages on an RP in a Cisco XR 12000 Series Router:

```
RP/0/0/CPU0:router# show install active location 0/0/cpu0

Node 0/0/CPU0 [RP]
  Boot Image: /disk0/c12k-rp-os-mpi-3.2.00/mbiprp-rp.vm
  Active Packages:
    disk0:c12k-mini-3.2.00
```

## Displaying the Committed Package Versions for Each Card

Committed packages are packages that are persistent across router reloads. If you install and activate a package, it remains active until the next router reload. If you install, activate, and commit a package, the package remains active across router reloads until the package is deactivated or replaced with another committed package.

Enter the **show install committed** command to verify that the desired set of packages is committed.

In the following example, the committed packages are shown:

```
RP/0/0/CPU0:router# show install committed

Node 0/0/CPU0 [RP]
  Boot Image: /disk0/c12k-rp-os-mpi-3.2.00/mbiprp-rp.vm
  Active Packages:
    disk0:c12k-mini-3.2.00

Node 0/3/CPU0 [LC(E3-OC3-POS-8)]
  Boot Image: /disk0/c12k-lc-os-mpi-3.2.00/gsr/ucode/mbi12000-lc.unicode
  Active Packages:
    disk0:c12k-mini-3.2.00

Node 0/4/CPU0 [LC(E3-GE-4)]
  Boot Image: /disk0/c12k-lc-os-mpi-3.2.00/gsr/ucode/mbi12000-lc.unicode
  Active Packages:
    disk0:c12k-mini-3.2.00

Node 0/5/CPU0 [LC(E3-GE-4)]
  Boot Image: /disk0/c12k-lc-os-mpi-3.2.00/gsr/ucode/mbi12000-lc.unicode
  Active Packages:
    disk0:c12k-mini-3.2.00

Node 0/6/CPU0 [LC(E3-OC48-POS)]
  Boot Image: /disk0/c12k-lc-os-mpi-3.2.00/gsr/ucode/mbi12000-lc.unicode
  Active Packages:
    disk0:c12k-mini-3.2.00

Node 0/7/CPU0 [LC(E3-GE-4)]
  Boot Image: /disk0/c12k-lc-os-mpi-3.2.00/gsr/ucode/mbi12000-lc.unicode
  Active Packages:
    disk0:c12k-mini-3.2.00
```

```

Node 0/8/CPU0 [LC(E3-OC12-POS-4)]
  Boot Image: /disk0/c12k-lc-os-mpi-3.2.00/gsr/ucode/mbi12000-lc.ucode
  Active Packages:
    disk0:c12k-mini-3.2.00

```

As with the **show install active** command, the **show install committed** command may display a composite package that represents all packages in the Cisco IOS XR Unicast Routing Core Bundle.

## Upgrading, Downgrading, and Installing Packages

The processes for upgrading, downgrading, and installing optional packages are introduced in the “[Information About Package Management](#)” section on page 5-18. The following sections describe features and procedures you can use to upgrade, downgrade, and install optional packages:

- [Controlling install Command Operation](#), page 5-26
- [Supported File Transfer Protocols](#), page 5-27
- [Copying Package Files from a Network Server to the Router](#), page 5-27
- [Adding Packages that are Resident on the Router](#), page 5-28
- [Adding Files from a Network Server](#), page 5-29
- [Activating a Package for All Appropriate Cards](#), page 5-30
- [Activating a Package for a Single Card](#), page 5-32
- [Adding and Activating Package Files in One Step from a Network Server](#), page 5-33

## Controlling install Command Operation

The **install** command is used in different forms to perform many package management tasks, such as adding, activating, and committing packages. Only one **install** command can run at a time. By default, the CLI prompt is returned to the screen before the installation operation is complete, which allows you to enter other noninstall commands. If additional installation requests are attempted before the first operation is complete, they are not executed.

To determine if an **install** command is currently running, enter the **show install request** command.

To delay the return of the CLI prompt until an installation operation is complete, enter the **install** command with the synchronous option. For example:

```
install add pie-file to device synchronous
```

```
install activate device:package synchronous
```



### Note

The **install add** and **install activate** commands must be executed in admin mode and are described later in this chapter.

## Supported File Transfer Protocols

PIE files can be copied from a file server to the router or directly installed from a network server using TFTP, FTP, SFTP, or rcp protocols (see [Table 5-5](#)).

**Table 5-5** Download Protocols Supported by Cisco IOS XR Software

Name	Description
Trivial File Transfer Protocol	TFTP is a simplified version of FTP that allows files to be transferred from one computer to another over a network, usually without the use of client authentication (for example, username and password).  <b>Note</b> Some Cisco IOS XR images may be larger than 32 MB, and the TFTP services provided by some vendors may not support a file this large. If you do not have access to a TFTP server that supports files larger than 32 MB, download the software image using FTP or rcp.
File Transfer Protocol	FTP is part of the TCP/IP protocol stack and requires a username and password.
Remote Copy Protocol	The rcp protocol uses TCP to ensure the reliable delivery of data, and rcp downloads require a usernames.
SSH File Transfer Protocol	SFTP is part of the SSHv2 feature in the Security package and provides for secure file transfers. For more information, see the <i>Cisco IOS XR System Security Configuration Guide</i> .

## Copying Package Files from a Network Server to the Router

The commands listed in [Table 5-6](#) show how to copy package files to the router from three types of network file servers.

**Table 5-6** Commands for Copying Package Files to the Router

Server Type	Command and Example
TFTP	The following command syntax is used: <b>copy tftp://hostname_or_ipaddress/directory-path/pie-name target-device</b>  Example: RP/0/RP0/CPU0:router# copy tftp://10.1.1.1/images/comp-hfr-full.pie disk1:
FTP	The following command syntax is used: <b>copy ftp://username:password@hostname_or_ipaddress/directory-path/pie-name target-device</b>  Example: RP/0/RP0/CPU0:router# copy ftp://john:secret@10.1.1.1/images/comp-hfr-full.pie disk1:
rcp	The following command syntax is used: <b>copy rcp://username@hostname_or_ipaddress/directory-path/pie-name target-device</b>  Example: RP/0/RP0/CPU0:router# copy rcp://john@10.1.1.1/images/comp-hfr-full.pie disk1:

Table 5-7 describes the command variables for copying and installing packages from a network server.

**Table 5-7 Command Variables for Copying and Installing Packages from a Network Server**

Variable	Description
<i>hostname_or_ipaddress</i>	Host name or IP address of the server that stores the source file.
<i>pie-name</i>	Name of the PIE file (package) to install. See the “Available Packages” section on page 5-1 for descriptions of the available PIE files.
<i>username</i>	Required for FTP and rcp only and must be a valid username on the FTP or rcp server.
<i>password</i>	Required for FTP only. If a password is not provided, the networking device accepts anonymous FTP.
<i>directory-path</i>	The specified directory should be a directory under the home directory of the user. In the rcp and FTP examples in this section, the file being downloaded is in a subdirectory called “images” in the home directory of the user “john.”  <b>Note</b> For FTP and rcp services, <i>directory-path</i> is the directory relative to the <i>username</i> home directory. If you want to specify an absolute path for the directory, you must add a “/” following the server address.
<i>target-device</i>	<ul style="list-style-type: none"> <li>disk0: PIE files are installed on flash disk0: with the <b>install add</b> command. disk0: is used only for installed and active software.</li> <li>disk1: PIE files can be copied to flash disk1: with the <b>copy</b> command. disk1: is used to store an archive of installation PIE files. Files can be copied to disk1: and then installed on disk0:.</li> </ul>

## Adding Packages that are Resident on the Router

After package files have been copied to the router, you can use the **install add** command to unpack PIE files and copy the enclosed software to disk0: on the primary RP. This process does not impact router operations. The following command syntax is used in admin EXEC mode:

### **install add pie-file to device**

The following example shows how to add the contents of a PIE file on disk0: to disk0:

```
RP/0/0/CPU0:router(admin)# install add disk0:c12k-mgbl.pie-3.2.00.1i to disk0:

Install: The idle timeout on this line will be suspended for synchronous install
operations
Install: Starting install operation. Do not insert or remove cards until the ope
ration completes.
RP/0/0/CPU0:router(admin)#
Install: Now operating in asynchronous mode. Do not attempt subsequent install o
perations until this operation is complete.
Install 1: [ 0%] Install operation 'add /disk0:c12k-mgbl.pie-3.2.00.1i to disk0
:' assigned request id: 1
Install 1: [ 1%] Downloaded the package to the router
Install 1: [ 1%] Verifying the package
Install 1: [ 1%] Verification of the package successful [OK]
Install 1: [ 95%] Going ahead to install the package...
Install 1: [ 95%] [OK]
Install 1: [ 95%] Add of '/disk0:c12k-mgbl.pie-3.2.00.1i' completed.
Install 1: [ 95%] Add successful.
Install 1: [ 95%] Downloading added packages to remote nodes.
Install 1: [100%] Successfully downloaded added packages to remote nodes.
Install 1: [100%] The following package(s) and/or SMU(s) are now available to be
activated:
```

```

Install 1: [100%]      disk0:c12k-mgbl-3.2.00
Install 1: [100%] Please carefully follow the instructions in the release notes
when activating any software
Install 1: [100%] Idle timeout on this line will now be resumed for synchronous
install operations

```

**Tip**

Make a note of the device and package names of the added package or packages. You must enter the device and package names to activate a package. In the preceding example, the device and package names for the added package are as follows: `disk0:c12k-k9sec-3.2.00`.

**Note**

Multiple versions of a software package can be added to the storage device without impacting the running configuration, but only one version of a package can be activated for a card.

## Adding Files from a Network Server

When you add a file from a network server, the PIE file is unpacked and its contents are stored on the local device. The commands listed in [Table 5-8](#) show how to add package files to the router from three types of network file servers.

**Table 5-8** Syntax for Copying and Adding Package Files to the Router

Server Type	Command and Example
TFTP	<p>The following command syntax is used in admin EXEC mode:</p> <p><b>install add tftp://hostname_or_ipaddress/directory-path/pie-name to target-device</b></p> <p>Example:</p> <pre>RP/0/0/CPU0:router(admin)# install add tftp://10.1.1.1/images/hfr-k9sec-p.pie to disk0:</pre>
FTP	<p>The following command syntax is used in admin EXEC mode:</p> <p><b>install add ftp://username:password@hostname_or_ipaddress/directory-path/pie-name to target-device</b></p> <p>Example:</p> <pre>RP/0/0/CPU0:router(admin)# install add ftp://john:secret@10.1.1.1/images/hfr-k9sec-p.pie to disk0:</pre>
rcp	<p>The following command syntax is used in admin EXEC mode:</p> <p><b>install add rcp://username@hostname_or_ipaddress/directory-path/pie-name to target-device</b></p> <p>Example:</p> <pre>RP/0/0/CPU0:router(admin)# install add rcp://john@10.1.1.1/images/gsr-k9sec-p.pie to disk0:</pre>

The following example shows how to add the Security package from a TFTP server to a Cisco XR 12000 Series Router:

```
RP/0/0/CPU0:router(admin)# install add tftp://10.1.1.1/software/c12k-k9sec.pie-3.2.00.1i to disk0:

Install: The idle timeout on this line will be suspended for synchronous install
operations
Install: Starting install operation. Do not insert or remove cards until the ope
ration completes.
RP/0/0/CPU0:router(admin)#
Install: Now operating in asynchronous mode. Do not attempt subsequent install o
perations until this operation is complete.
Install 1: [ 0%] Install operation 'add tftp://10.1.1.1/software/c12k-k9sec.pie-3.2.00.1i
to disk0:' assigned request id: 1
Install 1: [ 1%] Downloading PIE file from
/tftp://10.1.1.1/software/c12k-k9sec.pie-3.2.00.1i
Install 1: [ 1%]      Transferred 1320473 Bytes
Install 1: [ 1%] Downloaded the package to the router
Install 1: [ 1%] Verifying the package
Install 1: [ 1%] Verification of the package successful [OK]
Install 1: [ 95%] Going ahead to install the package...
Install 1: [ 95%] [OK]
Install 1: [ 95%] Add of '/tftp://10.1.1.1/software/c12k-k9sec.pie-3.2.00.1i' completed.
Install 1: [ 95%] Add successful.
Install 1: [ 95%] Downloading added packages to remote nodes.
Install 1: [100%] Successfully downloaded added packages to remote nodes.
Install 1: [100%] The following package(s) and/or SMU(s) are now available to be
activated:
Install 1: [100%]      disk0:c12k-k9sec-3.2.00
Install 1: [100%] Please carefully follow the instructions in the release notes
when activating any software
Install 1: [100%] Idle timeout on this line will now be resumed for synchronous
install operations
```

**Tip**

---

Make a note of the device and package names of the added package or packages. You must enter the device and package names to activate a package. In the preceding example, the device and package names for the added package are `disk0:c12k-k9sec-3.2.00`.

---

## Activating a Package for All Appropriate Cards

By default, packages are activated for all cards supported by that package. To activate a package on all router cards to which it applies, use the following command syntax in admin EXEC mode:

**install activate** *device: package*

Replace *device* with the name of a router storage device, such as `disk0:`, and replace *package* with the name of the installed package. Notice that the installed package name is different from the PIE file name and is displayed when the PIE file is added with the **install add** command. To see the installed packages that are available, enter the **dir** command for the device on which the packages are installed. For example:

```
RP/0/0/CPU0:router# dir disk0:

Directory of disk0:

 2          drwx  16384      Tue Oct 19 17:07:44 2004  LOST.DIR
 3          drwx  16384      Fri Nov 12 13:29:48 2004  c12k-lc-os-mbi-3.2.00
564         drwx  16384      Fri Nov 12 15:38:59 2004  instdb
566         drwx  16384      Fri Nov 12 13:31:30 2004  c12k-lc-base-3.2.00
2047        drwx  16384      Fri Nov 12 13:31:34 2004  c12k-lc-admin-3.2.00
2092        drwx  16384      Fri Nov 12 13:31:50 2004  c12k-lc-fwdg-3.2.00
2260        drwx  16384      Fri Nov 12 13:32:32 2004  c12k-lc-lc-3.2.00
2796        drwx  16384      Fri Nov 12 13:32:44 2004  c12k-rp-os-mbi-3.2.00
3281        drwx  16384      Fri Nov 12 13:36:56 2004  c12k-rp-base-3.2.00
6344        drwx  16384      Fri Nov 12 13:37:34 2004  c12k-rp-admin-3.2.00
6818        drwx  16384      Fri Nov 12 13:38:08 2004  c12k-rp-fwdg-3.2.00
7175        drwx  16384      Fri Nov 12 13:38:20 2004  c12k-rp-lc-3.2.00
7298        drwx  16384      Fri Nov 12 13:39:08 2004  c12k-rp-rout-3.2.00
 4          drwx  16384      Tue Oct 19 17:21:00 2004  shutdown
8014        drwx  16384      Thu Nov 11 09:36:16 2004  config
8045        dr-x  16384      Fri Nov 12 14:21:28 2004  aaa
8047        drwx  16384      Tue Oct 19 17:24:24 2004  usr
8048        drwx  16384      Tue Oct 19 17:24:24 2004  var
67072       -rwx  4440          Fri Nov 12 15:39:04 2004  sam_certdb
67168       -rwx  54027072    Fri Nov 12 10:47:48 2004  c12k-mini.vm-3.2.00.1i
67360       -rwx  126          Fri Nov 12 15:39:04 2004  sam_crldb
8099        drwx  16384      Wed Nov 10 23:37:40 2004  dumper
8144        drwx  16384      Fri Nov 12 14:10:12 2004  c12k-rp-k9sec-3.2.00
8126        drwx  16384      Fri Nov 12 15:38:59 2004  c12k-rp-mgb1-3.2.00

1024507904 bytes total (807059456 bytes free)
```

The package being activated must be compatible with the currently active software to operate. When an activation is attempted, the system runs an automatic compatibility check to ensure the package is compatible with the other active software on the router. The activation is permitted only after all compatibility checks have passed.



Tip

When activating packages, use the **test** option to test the effects of a command without impacting the running system. After the activation process completes, enter the **show install log** command to display the process results. To view an example of an activation with the test option and the information you can display, see [“Activating and Testing a Package on the Router: Example”](#) section on page 5-38.

The following example shows the activation of the Security package on a Cisco XR 12000 Series Router:

```
RP/0/0/CPU0:router(admin)# install activate disk0:c12k-rp-k9sec-3.2.00

Install: The idle timeout on this line will be suspended for synchronous install
operations
Install: Starting install operation. Do not insert or remove cards until the ope
ration completes.
RP/0/0/CPU0:router(admin)#
Install: Now operating in asynchronous mode. Do not attempt subsequent install o
perations until this operation is complete.
```

```

Install 3: [ 0%] Install operation 'activate disk0:c12k-rp-k9sec-3.2.00' assign
ed request id: 3

Install 3: [ 1%] Performing Inter-Package Card/Node/Scope Version Dependency Ch
ecks
Install 3: [ 1%] [OK]
Install 3: [ 1%] Checking API compatibility in software configurations...
Install 3: [ 1%] [OK]
Install 3: [ 10%] Updating software configurations.
Install 3: [ 10%] RP,DRP:
Install 3: [ 10%] Activating c12k-rp-k9sec-3.2.00
Install 3: [ 10%] Checking running configuration version compatibility with newl
y activated software ...
Install 3: [ 10%] No incompatibilities found between the activated software and
router running configuration.
Install 3: [ 10%] Node 0/0/CPU0: 6 c12k-rp-k9sec processes affected (0 updated,
6 added, 0 removed, 0 impacted)
Install 3: [ 55%] Downloading packages to impacted nodes
Install 3: [ 55%] Successfully downloaded packages to impacted nodesRP/0/0/CPU0:
Nov 12 14:23:21.188 : instdir[181]: %INSTMGR-6-SOFTWARE_CHANGE_START : Software
change transaction 3 is BEGINNING...

Install 3: [ 55%] Performing software change

```

This product contains cryptographic features and is subject to United States and local country laws governing import, export, transfer and use. Delivery of Cisco cryptographic products does not imply third-party authority to import, export, distribute or use encryption. Importers, exporters, distributors and users are responsible for compliance with U.S. and local country laws. By using this product you agree to comply with applicable laws and regulations. If you are unable to comply with U.S. and local laws, return this product immediately.

A summary of U.S. laws governing Cisco cryptographic products may be found at:

<http://www.cisco.com/wwl/export/crypto/tool/stqrg.html>

If you require further assistance please contact us by sending email to [export@cisco.com](mailto:export@cisco.com).

```

RP/0/0/CPU0:Nov 12 14:24:01.249 : instdir[181]: %INSTMGR-6-SOFTWARE_CHANGE_END :
Software change transaction 3 is COMPLETE.
Install 3: [100%] Performing software change
Install 3: [100%] Activation operation successful.
Install 3: [100%] NOTE: The changes made to software configurations will not be
Install 3: [100%] persistent across RP reloads. Use the command 'install commit'

Install 3: [100%] to make changes persistent.
Install 3: [100%] Idle timeout on this line will now be resumed for synchronous
install operations

```

## Activating a Package for a Single Card

To activate a package or an SMU for a specific card (node), enter the **install activate** command with the **location** option. The following command syntax is used in admin EXEC mode:

```
install activate device:package location nodeID
```

The following example shows the activation of the routing package on a single card:

```
RP/0/0/CPU0:router(admin)# install activate disk0:hfr-rout-1.0.0 location 0/2/CPU0
```



Tip

When activating packages, use the **test** option to test the effects of a command without impacting the running system. After the activation process completes, enter the **show install log** command to display the process results. To view an example of an activation with the **test** option and the information you can display, see the “[Activating and Testing a Package on the Router: Example](#)” section on page 5-38.

## Adding and Activating Package Files in One Step from a Network Server

Packages can be added to the router and activated with a single command by attaching the **activate** option to the **install add** command. The commands listed in [Table 5-9](#) show how to add and activate package files on the router from three types of network file servers.

**Table 5-9** Syntax for Adding and Activating Package Files on the Router

Server Type	Command and Example
TFTP	<p>The following command syntax is used in admin EXEC mode:</p> <p><b>install add tftp://hostname_or_ipaddress/directory-path/pie-name to target-device activate</b></p> <p>Example:</p> <pre>RP/0/RP0/CPU0:router(admin)# install add tftp://10.1.1.1/images/hfr-k9sec-p.pie to disk0: activate</pre>
FTP	<p>The following command syntax is used in admin EXEC mode:</p> <p><b>install add ftp://username:password@hostname_or_ipaddress/directory-path/pie-name to target-device activate</b></p> <p>Example:</p> <pre>RP/0/RP0/CPU0:router(admin)# install add ftp://john:secret@10.1.1.1/images/hfr-k9sec-p.pie to disk0: activate</pre>
rcp	<p>The following command syntax is used in admin EXEC mode:</p> <p><b>install add rcp://username@hostname_or_ipaddress/directory-path/pie-name to target-device activate</b></p> <p>Example:</p> <pre>RP/0/RP0/CPU0:router(admin)# install add rcp://john@10.1.1.1/images/gsr-k9sec-p.pie to disk0: activate</pre>



Tip

When activating packages, use the **test** option to test the effects of a command without impacting the running system. After the activation process completes, enter the **show install log** command to display the process results. To view an example of an activation with the **test** option and the information you can display, see the “[Activating and Testing a Package on the Router: Example](#)” section on page 5-38.

## Rolling Back to the Last Committed Package Set

To roll back to the last committed package set, enter the **install rollback committed** command in admin EXEC mode.



Tip

To display the committed package versions, enter the **show install committed** command.

In the following example, the system is rolled back to the last committed package set:

```
RP/0/0/CPU0:router(admin)# install rollback committed

Install: The idle timeout on this line will be suspended for synchronous install
operations
Install: Starting install operation. Do not insert or remove cards until the ope
ration completes.
RP/0/0/CPU0:router(admin)#
Install: Now operating in asynchronous mode. Do not attempt subsequent install o
perations until this operation is complete.
Install 5: [ 0%] Install operation 'rollback committed' assigned request id: 5
Install 5: [ 10%] Updating software configurations.
Install 5: [ 10%]   RP,DRP:
Install 5: [ 10%]   Deactivating c12k-rp-k9sec-3.2.00
Install 5: [ 10%] Checking running configuration version compatibility with newl
y activated software ...
Install 5: [ 10%] No incompatibilities found between the activated software and
router running configuration.
Install 5: [ 10%] Node 0/0/CPU0: 6 c12k-rp-k9sec processes affected (0 updated,
0 added, 6 removed, 0 impacted)
Install 5: [ 55%] Downloading packages to impacted nodes
Install 5: [ 55%] Successfully downloaded packages to impacted nodesRP/0/0/CPU0:
Nov 14 08:36:46.502 : instdir[181]: %INSTMGR-6-SOFTWARE_CHANGE_START : Software
change transaction 5 is BEGINNING...

P/0/0/CPU0:Nov 14 08:37:25.920 : instdir[181]: %INSTMGR-6-SOFTWARE_CHANGE_END :
Software change transaction 5 is COMPLETE.
[2KInstall 5: [100%] Performing software change
Install 5: [100%] Rollback operation successful.
Install 5: [100%] NOTE: The changes made to software configurations will not be
Install 5: [100%] persistent across RP reloads. Use the command 'install commit'

Install 5: [100%] to make changes persistent.
Install 5: [100%] Idle timeout on this line will now be resumed for synchronous
install operations
```

## Displaying Noncommitted Rollback Points

A noncommitted rollback point is created every time a software package is activated or deactivated. Beginning with Release 3.0, you can roll back the router to noncommitted rollback points. To display the eligible noncommitted rollback points, enter the **show install rollback ?** command as follows:

```
RP/0/0/CPU0:router# show install rollback ?

 0 ID of the rollback point to show package information for
 5 ID of the rollback point to show package information for
```

In this example, the valid noncommitted rollback points are 0 and 5. To display the package versions associated with one of these rollback points, enter the **show install rollback** command with the rollback point number as follows:

```
RP/0/0/CPU0:router# show install rollback 5

Node 0/0/CPU0 [RP]
  Boot Image: /c12k-rp-os-mpi-3.2.00/mbiprp-rp.vm
  Active Packages:
    mem:c12k-rp-k9sec-3.2.00
    mem:c12k-mini-3.2.00

Node 0/3/CPU0 [LC(E3-OC3-POS-8)]
  Boot Image: /c12k-lc-os-mpi-3.2.00/gsr/ucode/mbi12000-lc.ucode
  Active Packages:
    mem:c12k-mini-3.2.00

Node 0/4/CPU0 [LC(E3-GE-4)]
  Boot Image: /c12k-lc-os-mpi-3.2.00/gsr/ucode/mbi12000-lc.ucode
  Active Packages:
    mem:c12k-mini-3.2.00

Node 0/5/CPU0 [LC(E3-GE-4)]
  Boot Image: /c12k-lc-os-mpi-3.2.00/gsr/ucode/mbi12000-lc.ucode
  Active Packages:
    mem:c12k-mini-3.2.00

Node 0/6/CPU0 [LC(E3-OC48-POS)]
  Boot Image: /c12k-lc-os-mpi-3.2.00/gsr/ucode/mbi12000-lc.ucode
  Active Packages:
    mem:c12k-mini-3.2.00

Node 0/7/CPU0 [LC(E3-GE-4)]
  Boot Image: /c12k-lc-os-mpi-3.2.00/gsr/ucode/mbi12000-lc.ucode
  Active Packages:
    mem:c12k-mini-3.2.00

Node 0/8/CPU0 [LC(E3-OC12-POS-4)]
  Boot Image: /c12k-lc-os-mpi-3.2.00/gsr/ucode/mbi12000-lc.ucode
  Active Packages:
    mem:c12k-mini-3.2.00
```

## Rolling Back to a Noncommitted Rollback Point

Beginning in Release 3.0, you can roll back the system to noncommitted rollback points, which are described in the [“Displaying Noncommitted Rollback Points”](#) section on page 5-34. To roll back to a noncommitted rollback point, enter the **install rollback** command in admin EXEC mode with the rollback point number.



### Note

If you roll back to the most recent noncommitted rollback point (with the highest number), you do not need to reload the router. You can repeat the rollback process one rollback point at a time without reloading if you always choose the most recent rollback point. However, if you choose a rollback point that is older than the most recent point, you must enter the **install rollback** command with the **reload** option, which reloads the router and interrupts traffic.

**Tip**

---

To display the noncommitted rollback points, enter the **show install rollback ?** command.

---

In the following example, the system is rolled back to noncommitted rollback point 0:

```
RP/0/0/CPU0:router(admin)# install rollback 0

Install: The idle timeout on this line will be suspended for synchronous install
operations
Install: Starting install operation. Do not insert or remove cards until the ope
ration completes.
RP/0/0/CPU0:router(admin)#
Install: Now operating in asynchronous mode. Do not attempt subsequent install o
perations until this operation is complete.
Install 8: [ 0%] Install operation 'rollback 0' assigned request id: 8
Install 8: [ 10%] Updating software configurations.
Install 8: [ 10%]   RP,DRP:
Install 8: [ 10%]     Deactivating c12k-rp-k9sec-3.2.00
Install 8: [ 10%] Checking running configuration version compatibility with newl
y activated software ...
Install 8: [ 10%] No incompatibilities found between the activated software and
router running configuration.
Install 8: [ 10%] Node 0/0/CPU0: 6 c12k-rp-k9sec processes affected (0 updated,
0 added, 6 removed, 0 impacted)
Install 8: [ 55%] Downloading packages to impacted nodes
Install 8: [ 55%] Successfully downloaded packages to impacted nodes
Install 8: [100%] Performing software change
Install 8: [100%] Rollback operation successful.
Install 8: [100%] NOTE: The changes made to software configurations will not be
Install 8: [100%] persistent across RP reloads. Use the command 'install commit'

Install 8: [100%] to make changes persistent.
Install 8: [100%] Idle timeout on this line will now be resumed for synchronous
install operations
```

## Committing the Active Package Set

To make the current active package set persistent across router reloads, enter the **install commit** command in admin EXEC mode.

The following example shows the commitment of the active software on a Cisco XR 12000 Series Router:

```
RP/0/0/CPU0:router(admin)# install commit

Install: The idle timeout on this line will be suspended for synchronous install
operations
Install 6: [ 1%] Install operation 'commit' assigned request id: 6
Install 6: [100%] Committing uncommitted changes in software configuratons.
Install 6: [100%] Commit operation successful.
Install 6: [100%] Idle timeout on this line will now be resumed for synchronous
install operations
```

**Note**

---

If the system is reloaded before the current active software is made persistent with the **install commit** command, the previously committed software set is used.

---

## Deactivating a Package

When you deactivate a package, the package features are unavailable to the router. The package is still installed and can be activated later.

To deactivate a package, enter the **install deactivate** command in admin EXEC mode, as shown in the following example:

```
RP/0/0/CPU0:router(admin)# install deactivate disk0:c12k-rp-mgbl-3.90

Install: The idle timeout on this line will be suspended for synchronous install
operations
Install: Starting install operation. Do not insert or remove cards until the ope
ration completes.
RP/0/0/CPU0:router(admin)#
Install: Now operating in asynchronous mode. Do not attempt subsequent install o
perations until this operation is complete.
Install 8: [ 0%] Install operation 'deactivate disk0:c12k-rp-mgbl-3.2.00' assig
ned request id: 8
Install 8: [ 1%] Package 'disk0:c12k-rp-mgbl-3.2.00' is not active and cannot b
e deactivated.
Install 8: [ 1%] Idle timeout on this line will now be resumed for synchronous
install operations
```

## Removing Inactive Packages from the Router

To remove a package or an SMU from the router, you must first deactivate the package and commit the new active software set so it does not include the package. The three steps to remove inactive software are as follows:

1. **install deactivate** *package*
2. **install commit**
3. **install remove** *package*

Packages can be removed only if they are deactivated from all cards. A package cannot be deactivated if that package is required by another active package. When a deactivation is attempted, the system runs an automatic check to ensure that the package is not required by other active packages. The deactivation is permitted only after all compatibility checks have passed.



Tip

---

To preview the impact of a deactivation, enter the **test** option with the **install deactivate** command to display the results of the action without impacting the router.

---

## Configuration Examples for Managing Packages

This section provides the following package management examples:

- [Activating and Testing a Package on the Router: Example, page 5-38](#)

## Activating and Testing a Package on the Router: Example

To preview the impact of a package activation, enter the **install activate** command in admin EXEC mode with the **test** option. The **test** option displays the results of the operation without impacting the router. This option also assigns a “request ID” to the action, which can be used with the **show install log requestID** command to display the details of the test operation. For example:

```
RP/0/0/CPU0:router(admin)# install activate disk0:c12k-rp-mgbl-3.2.00 test

Install: The idle timeout on this line will be suspended for synchronous install
operations
Install: Starting install operation. Do not insert or remove cards until the ope
ration completes.
RP/0/0/CPU0:router(admin)#
Install: Now operating in asynchronous mode. Do not attempt subsequent install o
perations until this operation is complete.
Install 6: [ 0%] Install operation 'activate disk0:c12k-rp-mgbl-3.2.00 test' as
signed request id: 6
Install 6: [ 1%] WARNING! No changes will occur due to 'test' option.
Install 6: [ 1%] WARNING! The following is the predicted output for this instal
l command.
Install 6: [ 1%] Performing Inter-Package Card/Node/Scope Version Dependency Ch
ecks
Install 6: [ 1%] [OK]
Install 6: [ 1%] Checking API compatibility in software configurations...
Install 6: [ 1%] [OK]
Install 6: [ 10%] Updating software configurations.
Install 6: [ 10%] RP:
Install 6: [ 10%] Activating c12k-rp-mgbl-3.2.00
Install 6: [ 10%] WARNING! No incompatible configuration will be removed due to
the 'test' option
Install 6: [ 10%] Checking running configuration version compatibility with newl
y activated software ...
Install 6: [ 10%] No incompatibilities found between the activated software and
router running configuration.
Install 6: [ 10%] Node 0/0/CPU0: 5 c12k-rp-mgbl processes affected (0 updated, 5
added, 0 removed, 0 impacted)
Install 6: [ 10%] Activation operation successful.
Install 6: [ 10%] NOTE: The changes made to software configurations will not be
Install 6: [ 10%] persistent across RP reloads. Use the command 'install commit'

Install 6: [ 10%] to make changes persistent.
Install 6: [ 10%] WARNING! No changes have occurred due to 'test' option.
Install 6: [ 10%] Idle timeout on this line will now be resumed for synchronous
install operations

RP/0/0/CPU0:router(admin)# show install log 6

Request id 6 by lab at Thu Dec 02 06:38:24 2004:
  1 package activated: disk0:c12k-rp-mgbl-3.2.00 test

Summary:
  Node 0/0/CPU0: 5 c12k-rp-mgbl processes affected (0 updated, 5 added, 0
removed, 0 impacted)
```

## Status Information Logs:

```

WARNING! No changes will occur due to 'test' option.
WARNING! The following is the predicted output for this install command.
Performing Inter-Package Card/Node/Scope Version Dependency Checks
[OK]
Checking API compatibility in software configurations...
[OK]
Updating software configurations.
  RP:
    Activating c12k-rp-mgbl-3.2.00
WARNING! No incompatible configuration will be removed due to the 'test'
option
Checking running configuration version compatibility with newly activate
d software ...
No incompatibilities found between the activated software and router run
ning configuration.
Node 0/0/CPU0: 5 c12k-rp-mgbl processes affected (0 updated, 5 added, 0
removed, 0 impacted)
Activation operation successful.
NOTE: The changes made to software configurations will not be
persistent across RP reloads. Use the command 'install commit'
to make changes persistent.
WARNING! No changes have occurred due to 'test' option.

```

## Installation changes:

```

Installation changes on node 0/0/CPU0:
Adding executable: monitor_interface
Adding and starting process: pm_collector
Adding and starting process: pm_server
Adding and starting process: snmpingd
Adding executable: xml_demo_agent
Adding and starting process: xmlagent
Adding file: sh_ciscosensormib_ns_cfg_api.configinfo
Adding file: sh_emweb_ns_cfg_api.configinfo
Adding file: sh_frucontrolmib_ns_cfg_api.configinfo
Adding file: sh_perfmgmt_ns_cfg_api.configinfo
Adding file: sh_xmlagent_ns_cfg_api.configinfo
Adding file: comm.jar
Adding file: comm.jar.nonwindows
Adding file: craft.html
Adding file: cwi.xml
Adding file: cwi_desktop.jar
Adding file: cwi_help.zip
Adding file: cwi_if.jar
Adding file: cwi_ne.jar
Adding file: cwi_tools.jar
Adding file: javax.comm.properties
Adding file: launcher.jar
Adding file: libSerial.so.linux
Adding file: librxtxSerial.jnilib.mac
Adding file: orb.jar
Adding file: win32com.dll.win
Adding file: md5_manifest
Adding DLL: libhttperr.dll
Adding DLL: libpm_error.dll
Adding DLL: libtaoorbutils.dll
Adding DLL: libxmlcfgmgrdebug.dll
Adding DLL: libxmlcfgmgrerror.dll
Adding DLL: libxmlcfgmgrops.dll
Adding DLL: libxmlclierror.dll
Adding DLL: libxmlcliops.dll
Adding DLL: libxmlmdaddebug.dll

```

```
Adding DLL: libxmlmdaerror.dll
Adding DLL: libxmlmdaops.dll
Adding DLL: libxmlmdatrans.dll
Adding DLL: libxmlservice.dll
Adding DLL: libxmlserviceerror.dll
Adding DLL: libxmltarcfg.dll
Adding DLL: libbulkfilemib.dll
Adding DLL: libciscoassetmib.dll
Adding DLL: libciscosensormib.dll
Adding DLL: libfrucontrolmib.dll
Adding DLL: libftpclientmib.dll
Adding DLL: libpingmib.dll
Adding file: crs-mgbl--1.info
Adding file: crs-mgbl--10.info
Adding file: crs-mgbl--11.info
Adding file: crs-mgbl--12.info
Adding file: crs-mgbl--13.info
Adding file: crs-mgbl--14.info
Adding file: crs-mgbl--15.info
Adding file: crs-mgbl--16.info
Adding file: crs-mgbl--2.info
Adding file: crs-mgbl--3.info
Adding file: crs-mgbl--4.info
Adding file: crs-mgbl--5.info
Adding file: crs-mgbl--6.info
Adding file: crs-mgbl--7.info
Adding file: crs-mgbl--8.info
Adding file: crs-mgbl--9.info
Adding file: bulkfile.mib
Adding file: ciscoasset.mib
Adding file: ciscosensor.mib
Adding file: frucontrol.mib
Adding file: ftpclient.mib
Adding file: ping.mib
Adding file: bulkfilemib_cmds.parser
Adding file: cfg_emorb_cmds.parser
Adding file: cfg_emorb_xmlagent.parser
Adding file: cfg_perfmgmt.parser
Adding file: ciscoassetmib_cmds.parser
Adding file: ciscosensormib_cmds.parser
Adding file: frucontrolmib_cmds.parser
Adding file: ftpclientmib_cmds.parser
Adding file: http_cfg_cmds.parser
Adding file: http_debug_cmds.parser
Adding file: oper_perfmgmt.parser
Adding file: pingmib_cmds.parser
Adding file: xml_cfgmgr_debug.parser
Adding file: xml_cli_debug.parser
Adding file: xml_infra_debug.parser
Adding file: xml_mda_debug.parser
Adding file: sh_mgbl_ns_cfg__api.partitioninfo
Adding and starting process: emweb
Adding file: manageability_perf_cfg_common.schema
Adding file: manageability_perf_enable_monitor_cfg.schema
Adding file: manageability_perf_enable_stats_cfg.schema
Adding file: manageability_perf_enable_thresh_cfg.schema
Adding file: manageability_perf_oper.schema
Adding file: manageability_perf_stats_cfg.schema
Adding file: manageability_perf_thresh_cfg.schema
Adding file: httpd.startup
Adding file: pingmib.startup
Adding file: pm_collector.startup
Adding file: pm_server.startup
```

```
Adding file: xmlagent.startup
Replacing file: package_compatibility
```

Installation impact details:

```
Output format:
<Level> (<Impact>:<Note>) <Name> <Type>[package:component]
Level      : the distance from the process along the DLL dependency chain
Impact     : a one character indication of how this server or DLL is impacted:
              C modified; A added; R removed; I impacted by its dependencies
Note       : blank, or one of these annotations:
              d duplicate (this DLL has already been listed previously for this process)
              s self-managing (this server self-manages changes in its dependencies)
Name        : the name of this server or DLL
Type        : "server" or "DLL"
Package     : the Package containing this server or DLL
Component   : the source code component containing this server or DLL
Node class: RP
1 node(s): 0/0/CPU0

5 New Servers to be started
0 (A: ) pm_collector          server [c12k-rp-mgbl:managability-perf]
0 (A: ) pm_server            server [c12k-rp-mgbl:managability-perf]
0 (A: ) snmpingd             server [c12k-rp-mgbl:snmp-pingmib]
0 (A: ) xmlagent             server [c12k-rp-mgbl:generic-xmlagent]
0 (A: ) emweb                 server [c12k-rp-mgbl:emweb]
```

