



Configuring Frame Relay

Feature History

Release	Modification
Cisco IOS	For information about feature support in Cisco IOS software, use Cisco Feature Navigator.

This chapter describes the tasks for configuring Frame Relay on a router or access server.

Contents

- [Information About Frame Relay, page 1](#)
- [How to Configure Frame Relay, page 26](#)
- [Configuration Examples for Frame Relay, page 49](#)

Information About Frame Relay

- [Cisco Frame Relay MIB](#)
- [Frame Relay Hardware Configurations](#)
- [Frame Relay Encapsulation](#)
- [Dynamic or Static Address Mapping](#)
- [LMI](#)
- [Frame Relay SVCs](#)
- [Frame Relay Traffic Shaping](#)
- [Frame Relay Switching](#)
- [Frame Relay End-to-End Keepalives](#)
- [PPP over Frame Relay](#)
- [Understanding Frame Relay Subinterfaces](#)



Americas Headquarters:
Cisco Systems, Inc., 170 West Tasman Drive, San Jose, CA 95134-1706 USA

- [Disabling or Reenabling Frame Relay Inverse ARP](#)
- [Broadcast Queue for an Interface](#)
- [Frame Relay Fragmentation](#)
- [Payload Compression](#)
- [TCP/IP Header Compression](#)
- [Real-Time Header Compression with Frame Relay Encapsulation](#)
- [Discard Eligibility](#)
- [DLCI Priority Levels](#)

Cisco Frame Relay MIB

The Cisco Frame Relay MIB adds extensions to the standard Frame Relay MIB (RFC 1315). It provides additional link-level and virtual circuit (VC)-level information and statistics that are mostly specific to Cisco Frame Relay implementation. This MIB provides SNMP network management access to most of the information covered by the **show frame-relay** commands such as, **show frame-relay lmi**, **show frame-relay pvc**, **show frame-relay map**, and **show frame-relay svc**.

Frame Relay Hardware Configurations

You can create Frame Relay connections using one of the following hardware configurations:

- Routers and access servers connected directly to the Frame Relay switch
- Routers and access servers connected directly to a channel service unit/digital service unit (CSU/DSU), which then connects to a remote Frame Relay switch



Note

Routers can connect to Frame Relay networks either by direct connection to a Frame Relay switch or through CSU/DSUs. However, a single router interface configured for Frame Relay can be configured for only one of these methods.

The CSU/DSU converts V.35 or RS-449 signals to the properly coded T1 transmission signal for successful reception by the Frame Relay network. [Figure 1](#) illustrates the connections among the components.

Figure 1 Typical Frame Relay Configuration

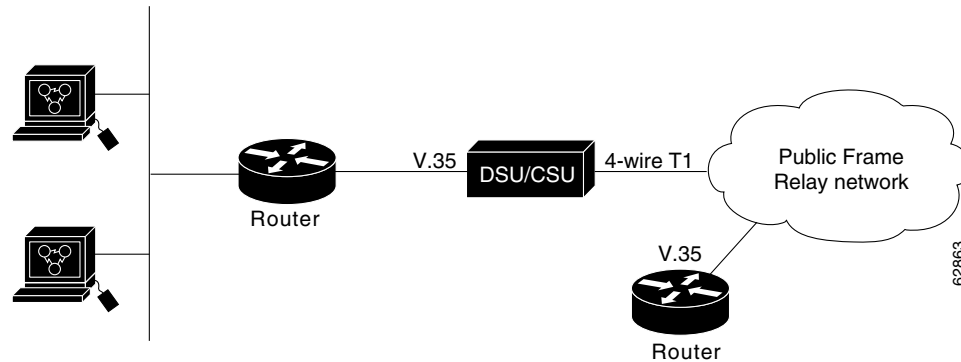

The Frame Relay interface actually consists of one physical connection between the network server and the switch that provides the service. This single physical connection provides direct connectivity to each device on a network.

Frame Relay Encapsulation

Frame Relay supports encapsulation of all supported protocols in conformance with RFC 1490, allowing interoperability among multiple vendors. Use the Internet Engineering Task Force (IETF) form of Frame Relay encapsulation if your router or access server is connected to another vendor's equipment across a Frame Relay network. IETF encapsulation is supported either at the interface level or on a per-VC basis.

Shut down the interface prior to changing encapsulation types. Although shutting down the interface is not required, it ensures that the interface is reset for the new encapsulation.

Dynamic or Static Address Mapping

- [Dynamic Address Mapping](#)
- [Static Address Mapping](#)

Dynamic Address Mapping

Dynamic address mapping uses Frame Relay Inverse ARP to request the next-hop protocol address for a specific connection, given its known DLCI. Responses to Inverse ARP requests are entered in an address-to-DLCI mapping table on the router or access server; the table is then used to supply the next-hop protocol address or the DLCI for outgoing traffic.

Inverse ARP is enabled by default for all protocols it supports, but can be disabled for specific protocol-DLCI pairs. As a result, you can use dynamic mapping for some protocols and static mapping for other protocols on the same DLCI. You can explicitly disable Inverse ARP for a protocol-DLCI pair if you know that the protocol is not supported on the other end of the connection. See the section [“Disabling or Reenabling Frame Relay Inverse ARP”](#) for more information.



Note

Because Inverse ARP is enabled by default, no additional command is required to configure dynamic mapping on an interface and packets are not sent out for protocols that are not enabled on the interface.

Static Address Mapping

A static map links a specified next-hop protocol address to a specified DLCI. Static mapping removes the need for Inverse ARP requests; when you supply a static map, Inverse ARP is automatically disabled for the specified protocol on the specified DLCI. You must use static mapping if the router at the other end either does not support Inverse ARP at all or does not support Inverse ARP for a specific protocol that you want to use over Frame Relay.

You can simplify the configuration for the Open Shortest Path First (OSPF) protocol by adding the optional **broadcast** keyword when doing this task. Refer to the **frame-relay map** command description in the *Cisco IOS Wide-Area Networking Command Reference* and the examples at the end of this chapter for more information about using the **broadcast** keyword.

LMI

Beginning with Cisco IOS Release 11.2, the software supports Local Management Interface (LMI) autosense, which enables the interface to determine the LMI type supported by the switch. Support for LMI autosense means that you are no longer required to configure the LMI explicitly.

LMI autosense is active in the following situations:

- The router is powered up or the interface changes state to up.
- The line protocol is down but the line is up.
- The interface is a Frame Relay DTE.
- The LMI type is not explicitly configured.

Activating LMI Autosense

- [Status Request](#)
- [Status Messages](#)
- [LMI Autosense](#)
- [Configuration Options](#)

Status Request

When LMI autosense is active, it sends out a full status request, in all three LMI types, to the switch. The order is ANSI, ITU, cisco, but it is done in rapid succession. Cisco IOS software provides the ability to listen in on both DLCI 1023 (cisco LMI) and DLCI 0 (ANSI and ITU) simultaneously.

Status Messages

One or more of the status requests will elicit a reply (status message) from the switch. The router will decode the format of the reply and configure itself automatically. If more than one reply is received, the router will configure itself with the type of the last received reply. This is to accommodate intelligent switches that can handle multiple formats simultaneously.

LMI Autosense

If LMI autosense is unsuccessful, an intelligent retry scheme is built in. Every N391 interval (default is 60 seconds, which is 6 keep exchanges at 10 seconds each), LMI autosense will attempt to ascertain the LMI type. For more information about N391, see the **frame-relay lmi-n391dte** command in the chapter “Frame Relay Commands” in the *Cisco IOS Wide-Area Networking Command Reference*.

The only visible indication to the user that LMI autosense is under way is that **debug frame lmi** is turned on. At every N391 interval, the user will now see three rapid status inquiries coming out of the serial interface: one in ANSI, one in ITU, and one in cisco LMI-type.

Configuration Options

No configuration options are provided; LMI autosense is transparent to the user. You can turn off LMI autosense by explicitly configuring an LMI type. The LMI type must be written into NVRAM so that next time the router powers up, LMI autosense will be inactive. At the end of autoinstall, a **frame-relay lmi-type xxx** statement is included within the interface configuration. This configuration is not automatically written to NVRAM; you must explicitly write the configuration to NVRAM by using the **copy system:running-config** or **copy nvram:startup-config** command.

Frame Relay SVCs

Access to Frame Relay networks is made through private leased lines at speeds ranging from 56 kbps to 45 Mbps. Frame Relay is a connection-oriented packet-transfer mechanism that establishes VCs between endpoints.

Switched virtual circuits (SVCs) allow access through a Frame Relay network by setting up a path to the destination endpoints only when the need arises and tearing down the path when it is no longer needed.

SVCs can coexist with PVCs in the same sites and routers. For example, routers at remote branch offices might set up PVCs to the central headquarters for frequent communication, but set up SVCs with each other as needed for intermittent communication. As a result, any-to-any communication can be set up without any-to-any PVCs.

On SVCs, quality of service (QoS) elements can be specified on a call-by-call basis to request network resources.

SVC support is offered in the Enterprise image on Cisco platforms that include a serial or HSSI interface.

You must have the following services before Frame Relay SVCs can operate:

- Frame Relay SVC support by the service provider—The service provider’s switch must be capable of supporting SVC operation.
- Physical loop connection—A leased line or dedicated line must exist between the router (DTE) and the local Frame Relay switch.

Operating SVCs

SVC operation requires that the Data Link layer (Layer 2) be set up, running ITU-T Q.922 Link Access Procedures to Frame mode bearer services (LAPF), prior to signalling for an SVC. Layer 2 sets itself up as soon as SVC support is enabled on the interface, if both the line and the line protocol are up. When the SVCs are configured and demand for a path occurs, the Q.933 signalling sequence is initiated. Once the SVC is set up, data transfer begins.

Q.922 provides a reliable link layer for Q.933 operation. All Q.933 call control information is transmitted over DLCI 0; this DLCI is also used for the management protocols specified in ANSI T1.617 Annex D or Q.933 Annex A.

You must enable SVC operation at the interface level. Once it is enabled at the interface level, it is enabled on any subinterfaces on that interface. One signalling channel, DLCI 0, is set up for the interface, and all SVCs are controlled from the physical interface.

Frame Relay Traffic Shaping

Traffic shaping applies to both PVCs and SVCs. Enabling Frame Relay traffic shaping on an interface enables both traffic shaping and per-VC queueing on all the PVCs and SVCs on the interface. Traffic shaping enables the router to control the circuit's output rate and react to congestion notification information if also configured.



Note

Frame Relay traffic shaping is not effective for Layer 2 PVC switching using the **frame-relay route** command.

- [Defining VCs for Different Types of Traffic](#)
- [Frame Relay ForeSight](#)
- [Frame Relay Congestion Notification Methods](#)
- [Enhanced Local Management Interface](#)
- [Traffic-Shaping Map Class for the Interface](#)
- [Specifying Map Class with Queueing and Traffic-Shaping Parameters](#)
- [Defining Access Lists](#)
- [Defining Priority Queue Lists for the Map Class](#)
- [Defining Custom Queue Lists for the Map Class](#)

Defining VCs for Different Types of Traffic

By defining separate VCs for different types of traffic and specifying queueing and an outbound traffic rate for each VC, you can provide guaranteed bandwidth for each type of traffic. By specifying different traffic rates for different VCs over the same line, you can perform virtual time division multiplexing. By throttling outbound traffic from high-speed lines in central offices to lower-speed lines in remote locations, you can ease congestion and data loss in the network; enhanced queueing also prevents congestion-caused data loss.

Frame Relay ForeSight

ForeSight is the network traffic control software used in some Cisco switches. The Cisco Frame Relay switch can extend ForeSight messages over a User-to-Network Interface (UNI), passing the backward congestion notification for VCs.

ForeSight allows Cisco Frame Relay routers to process and react to ForeSight messages and adjust VC level traffic shaping in a timely manner.

ForeSight must be configured explicitly on both the Cisco router and the Cisco switch. ForeSight is enabled on the Cisco router when Frame Relay traffic shaping is configured. However, the router's response to ForeSight is not applied to any VC until the **frame-relay adaptive-shaping foresight** command is added to the VCs map-class. When ForeSight is enabled on the switch, the switch will periodically send out a ForeSight message based on the time value configured. The time interval can range from 40 to 5000 milliseconds.

When a Cisco router receives a ForeSight message indicating that certain DLCIs are experiencing congestion, the Cisco router reacts by activating its traffic-shaping function to slow down the output rate. The router reacts as it would if it were to detect the congestion by receiving a packet with the backward explicit congestion notification (BECN) bit set.

When ForeSight is enabled, Frame Relay traffic shaping will adapt to ForeSight messages and BECN messages.

Frame Relay ForeSight Prerequisites

For router ForeSight to work, the following conditions must exist on the Cisco router:

- Frame Relay traffic shaping must be enabled on the interface.
- The traffic shaping for a circuit is adapted to ForeSight.

The following additional condition must exist on the Cisco switch:

- The UNI connecting to the router is Consolidated Link Layer Management (CLLM) enabled, with the proper time interval specified.

Frame Relay router ForeSight is enabled automatically when you use the **frame-relay traffic-shaping** command. However, you must issue the **map-class frame-relay** command and the **frame-relay adaptive-shaping foresight** command before the router will respond to ForeSight and apply the traffic-shaping effect on a specific interface, subinterface, or VC.

Frame Relay Congestion Notification Methods

The difference between the BECN and ForeSight congestion notification methods is that BECN requires a user packet to be sent in the direction of the congested DLCI to convey the signal. The sending of user packets is not predictable and, therefore, not reliable as a notification mechanism. Rather than waiting for user packets to provide the congestion notification, timed ForeSight messages guarantee that the router receives notification before congestion becomes a problem. Traffic can be slowed down in the direction of the congested DLCI.

Enhanced Local Management Interface

Enhanced Local Management Interface (ELMI) allows the router to learn QoS parameters and connectivity information from the Cisco switch and to use this information for traffic shaping, configuration, or management purposes. ELMI simplifies the process of configuring traffic shaping on the router and reduces chances of specifying inconsistent or incorrect values when configuring the router. ELMI works between Cisco routers and Cisco switches (BPX and IGX platforms).

ELMI QoS Autosense

When used in conjunction with traffic shaping, ELMI enables the router to respond to changes in the network dynamically. ELMI enables automated exchange of Frame Relay QoS parameter information between the Cisco router and the Cisco switch. [Figure 2](#) illustrates a Cisco switch and a Cisco router, both configured with ELMI enabled. The switch sends QoS information to the router, which uses it for traffic rate enforcement.

Figure 2 *Enhanced Local Management Interface—Sent Between the Cisco Switch and the Cisco Router*

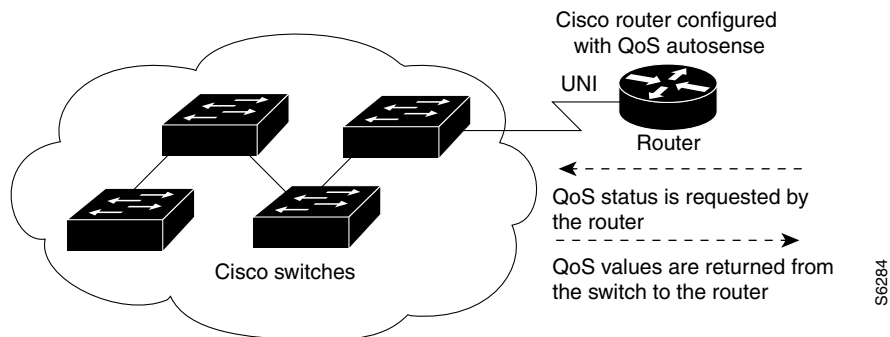

Routers can base congestion management and prioritization decisions on known QoS values, such as the Committed Information Rate (CIR), Committed Burst Size (Bc), and Excess Burst Size (Be). The router senses QoS values from the switch and can be configured to use those values in traffic shaping.

It is not necessary to configure traffic shaping on the interface to enable ELMI, but you may want to do so in order to know the values being used by the switch. If you want the router to respond to the QoS information received from the switch by adjusting the output rate, you must configure traffic shaping on the interface. To configure traffic shaping, use the **frame-relay traffic-shaping** command in interface configuration mode.

ELMI Address Registration

ELMI address registration enables a network management system (NMS) to detect connectivity among Cisco switches and routers in a network using the ELMI protocol. During ELMI version negotiation, neighboring devices exchange their management IP addresses and ifIndex. The NMS polls the devices and uses the Cisco Frame Relay MIB to collect this connectivity information. ELMI address registration allows for autodetection of the complete network topology.

[Figure 3](#) shows a typical network in which ELMI address registration is in use.

Figure 3 Connectivity Detection Using ELMI Address Registration

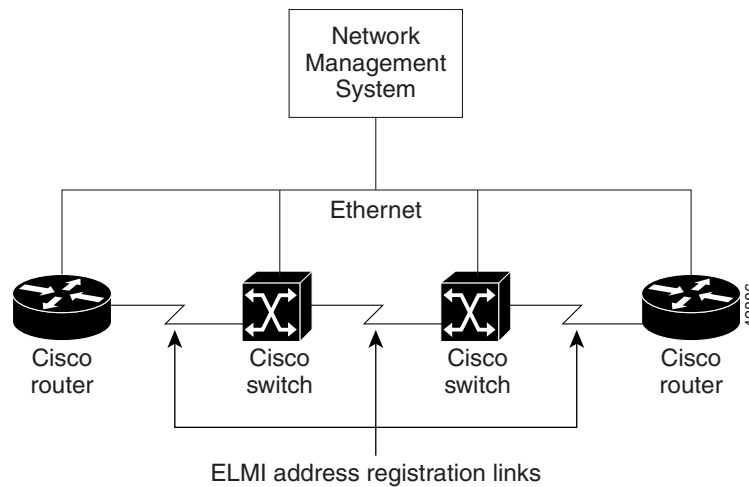

ELMI address registration takes place on all interfaces on which ELMI is enabled, even if all the interfaces are connected to the same router or switch. The router periodically sends a version inquiry message with version information, the management IP address, and ifIndex to the switch. The switch sends its management IP address and ifIndex using the version status message. When the management IP address of the switch changes, an asynchronous ELMI version status message is immediately sent to the neighboring device.



Note

The ELMI address registration mechanism does not check for duplicate or illegal addresses.

When ELMI is enabled, the router automatically chooses the IP address of one of the interfaces to use for ELMI address registration purposes. The router will choose the IP address of an Ethernet interface first, and then serial and other interfaces. You have the option to use the IP address chosen by the router or to disable the autoaddress mechanism and configure the management IP address yourself. You can also choose to disable ELMI address registration on a specific interface or on all interfaces.

Traffic-Shaping Map Class for the Interface

If you specify a Frame Relay map class for a main interface, all the VCs on its subinterfaces inherit all the traffic-shaping parameters defined for the class. You can override the default for a specific DLCI on a specific subinterface by using the **class VC** configuration command to assign the DLCI explicitly to a different class. See the section [“Configuring Frame Relay Subinterfaces”](#) for information about setting up subinterfaces.

For an example of assigning subinterface DLCIs to the default class and assigning others explicitly to a different class, see the section [“Example: Frame Relay Traffic Shaping”](#).

Specifying Map Class with Queueing and Traffic-Shaping Parameters

When defining a map class for Frame Relay, you can specify the average and peak rates (in bits per second) allowed on VCs associated with the map class. You can also specify *either* a custom queue list *or* a priority queue group to use on VCs associated with the map class.

Defining Access Lists

You can specify access lists and associate them with the custom queue list defined for any map class. The list number specified in the access list and the custom queue list tie them together. See the appropriate protocol chapters for information about defining access lists for the protocols you want to transmit on the Frame Relay network.

Defining Priority Queue Lists for the Map Class

You can define a priority list for a protocol and you can also define a default priority list. The number used for a specific priority list ties the list to the Frame Relay priority group defined for a specified map class. For example, if you enter the **frame relay priority-group 2** command for the map class “fast_vcs” and then you enter the **priority-list 2 protocol decnet high** command, that priority list is used for the “fast_vcs” map class. The average and peak traffic rates defined for the “fast_vcs” map class are used for DECnet traffic.

Defining Custom Queue Lists for the Map Class

You can define a queue list for a protocol and a default queue list. You can also specify the maximum number of bytes to be transmitted in any cycle. The number used for a specific queue list ties the list to the Frame Relay custom queue list defined for a specified map class.

For example, if you enter the **frame relay custom-queue-list 1** command for the map class “slow_vcs” and then you enter the **queue-list 1 protocol ip list 100** command, that queue list is used for the “slow_vcs” map class; **access-list 100** definition is also used for that map class and queue. The average and peak traffic rates defined for the “slow_vcs” map class are used for IP traffic that meets the **access list 100** criteria.

Frame Relay Switching

Frame Relay switching is a means of switching packets based on the DLCI, which can be considered the Frame Relay equivalent of a MAC address. You perform switching by configuring your Cisco router or access server into a Frame Relay network. There are two parts to a Frame Relay network:

- Frame Relay DTE (the router or access server)
- Frame Relay DCE switch

[Figure 4](#) illustrates Frame Relay switched networks. Routers A, B, and C are Frame Relay DTEs connected to each other via a Frame Relay network.

Figure 4 Frame Relay Switched Network

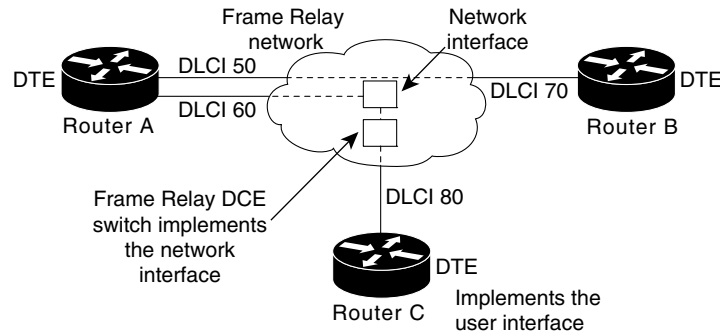

Frame Relay switching is supported on the following interface types:

- Serial interfaces
- ISDN interfaces



Note

Frame Relay switching is not supported on subinterfaces.

Frame Relay Switching over ISDN B Channels

Frame Relay switching over ISDN B channels enables you to transport Frame Relay data over ISDN. This feature allows small offices to be hubbed out of larger offices rather than being connected directly to the core network. The hub router acts as a Frame Relay switch, switching between ISDN and serial interfaces, as shown in [Figure 5](#).

Figure 5 Router Used As a Frame Relay Switch over ISDN

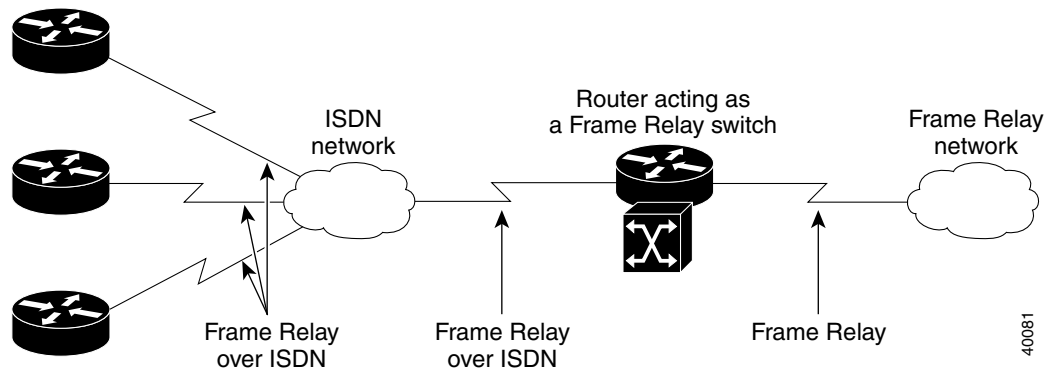

Frame Relay switching over ISDN provides the following functionality:

- LMI is supported on ISDN Frame Relay DCE interfaces.
- A single BRI/PRI interface can use a combination of switched PVCs and terminated Frame Relay PVCs.
- Frame Relay switching supports both leased-line ISDN, on which a B channel is permanently connected, and switched ISDN, on which B channels may be dynamically set up and torn down.

Note the following restrictions for Frame Relay switching over ISDN:

- Frame Relay traffic shaping is not supported on ISDN interfaces.
- The router configured for Frame Relay switching over ISDN cannot initiate the ISDN call.
- PVC-level congestion management is not supported over ISDN. Interface-level congestion management is supported.

When Frame Relay switching is performed by using a dialer profile, encapsulation of the underlying physical (BRI) interface must be configured as high-level data link control (HDLC).

Frame Relay Traffic Shaping on Switched PVCs

Applying Frame Relay traffic shaping to switched PVCs enables a router to be used as a Frame Relay port concentrator in front of a Frame Relay switch. The Frame Relay switch will shape the concentrated traffic before sending it into the network. [Figure 6](#) shows the network configuration.

Figure 6 Router Used As a Frame Relay Port Concentrator

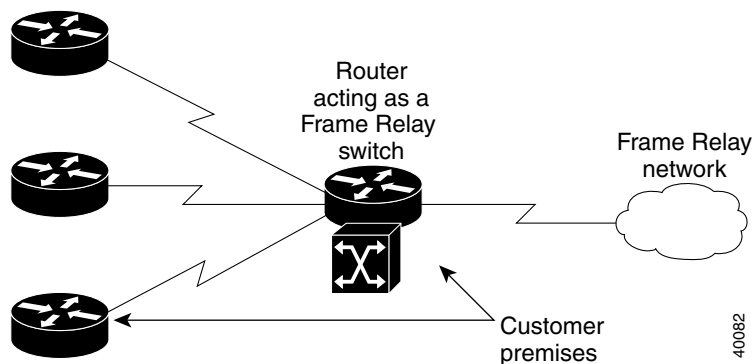

When you configure traffic shaping, you will define the traffic-shaping parameters in a Frame Relay map class and then attach the map class to the interface or a single switched PVC. All the traffic-shaping map-class parameters are applicable to switched PVCs: namely, Bc, Be, CIR, minimum CIR, average rate, peak rate, and adaptive shaping.

Frame Relay traffic shaping must be enabled on the interface before traffic-shaping map-class parameters will be effective. Note that when you enable Frame Relay traffic shaping, all PVCs, switched and terminated, will be shaped on that interface. Switched PVCs that are not associated with a map class will inherit shaping parameters from the interface or use default values.

Traffic Policing

Traffic policing prevents congestion on incoming PVCs by discarding or setting the DE bit on packets that exceed specified traffic parameters.

You can associate the map class with the interface or individual switched PVCs. Switched PVCs that are not associated with a map class will inherit policing parameters from the interface.

If you use a map class to configure both traffic policing and shaping, use the **in** keyword to specify incoming traffic for policing and the **out** keyword to specify outgoing traffic for shaping. If you configure shaping on one segment of a switched PVC and policing on the other, the shaping parameters will be derived from the policing parameters unless you specifically define shaping parameters in the map class.

Congestion Management on Switched PVCs

Frame Relay congestion management can be used to manage outgoing traffic congestion on switched PVCs. When Frame Relay congestion management is enabled, one way that the router manages congestion is by setting backward explicit congestion notification (BECN) and forward explicit congestion notification (FECN) bits on packets. When a switched PVC or interface is congested, packets experiencing congestion are marked with the FECN bit, and packets traveling in the reverse direction are marked with the BECN bit. When these bits reach a user device at the end of the network, the user device can react to the ECN bits and adjust the flow of traffic.

When the output interface queue reaches or exceeds the ECN excess threshold, Frame Relay bit packets on all PVCs crossing that interface will be marked with FECN or BECN, depending on their direction of travel. When the queue reaches or exceeds the ECN committed threshold, all Frame Relay packets will be marked with FECN or BECN.

A second way the router manages congestion is by discarding Frame Relay packets that are marked with the discard eligible (DE) bit and that exceed a specified level of congestion.

When the queue reaches or exceeds the DE threshold, Frame Relay packets with the DE bit will be discarded rather than queued.

You can define two levels of congestion. The first level applies to individual PVCs transmitting traffic in excess of the committed information rate (CIR). The second level applies to all PVCs at an interface. This scheme allows you to adjust the congestion on PVCs transmitting above the CIR before applying congestion management measures to all PVCs.

Congestion management parameters can be configured on the output interface queue and on traffic-shaping queues.

FRF.12 Fragmentation on Switched PVCs

The FRF.12 Implementation Agreement allows long data frames to be fragmented into smaller pieces. This process allows real-time traffic and non-real-time traffic to be carried together on lower-speed links without causing excessive delay to the real-time traffic. For further information about FRF.12 fragmentation, see the section [“End-to-End FRF.12 Fragmentation”](#) later in this module.

Some Frame Relay access devices do not support the FRF.12 standard for end-to-end fragmentation. Large packets sourced from these devices can cause significant serialization delay across low-speed trunks in switched networks. Using FRF.12 fragmentation can help prevent this delay. An edge router that receives large packets from a Frame Relay access device will fragment those packets before transmitting them across the switched network. The edge router that receives the fragmented packets will reassemble those packets before sending them to a Frame Relay access device that does not support FRF.12. If the receiving Frame Relay access device does support FRF.12, the router will transmit the fragmented packets without reassembling them.

Note the following conditions and restrictions on FRF.12 fragmentation on switched PVCs:

- Frame Relay traffic shaping must be enabled.
- Interface queuing must be dual FIFO queuing or PVC interface priority queuing.
- Switched PVCs must be configured using the **connect** command.
- If the Frame Relay access device does not support FRF.12 fragmentation, the FRF.12 Support on Switched Frame Relay PVCs feature will not benefit the interface between the Frame Relay access device and the edge router. Fragmentation and reassembly occur on the interface between the edge router and the switched Frame Relay network.

- If the Frame Relay access device is sending voice and unfragmented data on the same PVC, voice quality will suffer. The edge router will not reorder packets on switched PVCs.

Frame Relay End-to-End Keepalives

Frame Relay end-to-end keepalives enable monitoring of PVC status for network monitoring or backup applications and are configurable on a per-PVC basis with configurable timers. The Frame Relay switch within the local PVC segment deduces the status of the remote PVC segment through a Network-to-Network Interface (NNI) and reports the status to the local router. If LMI support within the switch is not end-to-end, end-to-end keepalives are the only source of information about the remote router. End-to-end keepalives verify that data is getting through to a remote device via end-to-end communication.

Each PVC connecting two end devices needs two separate keepalive systems, because the upstream path may not be the same as the downstream path. One system sends out requests and handles responses to those requests—the send side—while the other system handles and replies to requests from the device at the other end of the PVC—the receive side. The send side on one device communicates with the receive side on the other device, and vice versa.

The send side sends out a keepalive request and waits for a reply to its request. If a reply is received before the timer expires, a send-side Frame Relay end-to-end keepalive is recorded. If no reply is received before the timer expires, an error event is recorded. A number of the most recently recorded events are examined. If enough error events are accumulated, the keepalive status of the VC is changed from up to down, or if enough consecutive successful replies are received, the keepalive status of the VC is changed from down to up. The number of events that will be examined is called the *event window*.

The receive side is similar to the send side. The receive side waits for requests and sends out replies to those requests. If a request is received before the timer expires, a success event is recorded. If a request is not received, an error event is recorded. If enough error events occur in the event window, the PVC state will be changed from up to down. If enough consecutive success events occur, the state will be changed from down to up.

End-to-end keepalives can be configured in one of four modes: bidirectional, request, reply, or passive-reply.

- In bidirectional mode, both the send side and the receive side are enabled. The send side of the device sends out and waits for replies to keepalive requests from the receive side of the other PVC device. The receive side of the device waits for and replies to keepalive requests from the send side of the other PVC device.
- In request mode, only the send side is enabled, and the device sends out and waits for replies to its keepalive requests.
- In reply mode, only the receive side is enabled, and the device waits for and replies to keepalive requests.
- In passive-reply mode, the device only responds to keepalive requests, but does not set any timers or keep track of any events.

Because end-to-end keepalives allow traffic flow in both directions, they can be used to carry control and configuration information from end to end. Consistency of information between end hosts is critical in applications such as those relating to prioritized traffic and Voice over Frame Relay. Whereas SVCs can convey such information within end-to-end signalling messages, PVCs will benefit from a bidirectional communication mechanism.

End-to-end keepalives are derived from the Frame Relay LMI protocol and work between peer Cisco communications devices. The key difference is that rather than running over the signalling channel, as is the case with LMI, end-to-end keepalives run over individual data channels.

Encapsulation of keepalive packets is proprietary; therefore, the feature is available only on Cisco devices running a software release that supports the Frame Relay End-to-End Keepalive feature.

You must configure both ends of a VC to send keepalives. If one end is configured as bidirectional, the other end must also be configured as bidirectional. If one end is configured as request, the other end must be configured as reply or passive-reply. If one end is configured as reply or passive-reply, the other end must be configured as request

PPP over Frame Relay

Point-to-point protocol (PPP) over Frame Relay allows a router to establish end-to-end PPP sessions over Frame Relay. This is done over a PVC, which is the only circuit currently supported. The PPP session does not occur unless the associated Frame Relay PVC is in an “active” state. The Frame Relay PVC can coexist with other circuits using different Frame Relay encapsulation methods, such as RFC 1490 and the Cisco proprietary method, over the same Frame Relay link. There can be multiple PPP over Frame Relay circuits on one Frame Relay link.

One PPP connection resides on one virtual access interface. This is internally created from a virtual template interface, which contains all necessary PPP and network protocol information and is shared by multiple virtual access interfaces. The virtual access interface is coexistent with the creation of the Frame Relay circuit when the corresponding DLCI is configured. Hardware compression and fancy queueing algorithms, such as weighted fair queueing, custom queueing, and priority queueing, are not applied to virtual access interfaces.

PPP over Frame Relay is only supported on IP. IP datagrams are transported over the PPP link using RFC 1973 compliant Frame Relay framing. The frame format is shown in [Figure 7](#).

Figure 7 PPP over Frame Relay Frame Format

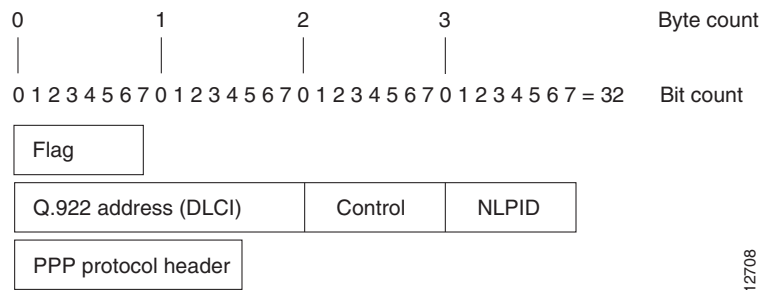

[Table 1](#) lists the Frame Relay frame format components illustrated in [Figure 7](#).

Table 1 PPP Frame Relay Frame Format Descriptions

Field	Description
Flag	A single byte that indicates the beginning or end of a frame.
Address	A two-byte field that indicates the logical connection that maps to the physical channel; the DLCI.
Control	A single byte that calls for transmission of user data. PPP over Frame Relay uses a value of 0X03, which indicates that the frame is an unnumbered information (UI) frame.

Table 1 PPP Frame Relay Frame Format Descriptions (continued)

Field	Description
NLPID	Network layer protocol ID—a single byte that uniquely identifies a PPP packet to Frame Relay.
PPP protocol	PPP packet type.

Figure 8 shows remote users running PPP to access their Frame Relay corporate networks.

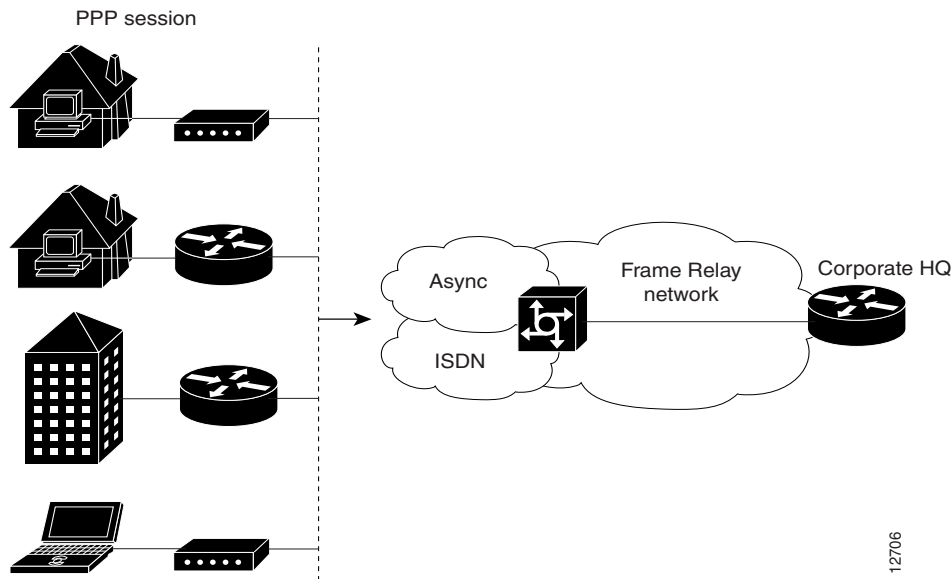
Figure 8 PPP over Frame Relay Scenario

Before PPP over Frame Relay is configured, Frame Relay must be enabled on the router using the **encapsulation frame-relay** command. The only task required in order to implement PPP over Frame Relay is to configure the interface with the locally terminated PVC and the associated virtual template for PPP and IP, as described in the following section.

After configuring Frame Relay encapsulation on the Cisco router or access server, you must configure the physical interface with the PVC and apply a virtual template with PPP encapsulation to the DLCI.

Understanding Frame Relay Subinterfaces

Frame Relay subinterfaces provide a mechanism for supporting partially meshed Frame Relay networks. Most protocols assume *transitivity* on a logical network; that is, if station A can talk to station B, and station B can talk to station C, then station A should be able to talk to station C directly. Transitivity is true on LANs, but not on Frame Relay networks unless A is directly connected to C.

Additionally, certain protocols such as AppleTalk and transparent bridging cannot be supported on partially meshed networks because they require *split horizon*. Split horizon is a routing technique in which a packet received on an interface cannot be sent from the same interface even if received and transmitted on different VCs.

Configuring Frame Relay subinterfaces ensures that a single physical interface is treated as multiple virtual interfaces. This treatment allows you to overcome split horizon rules. Packets received on one virtual interface can be forwarded to another virtual interface even if they are configured on the same physical interface.

Subinterfaces address the limitations of Frame Relay networks by providing a way to subdivide a partially meshed Frame Relay network into a number of smaller, fully meshed (or point-to-point) subnetworks. Each subnetwork is assigned its own network number and appears to the protocols as if it were reachable through a separate interface. (Note that point-to-point subinterfaces can be unnumbered for use with IP, reducing the addressing burden that might otherwise result.)

[Figure 9](#) shows a five-node Frame Relay network that is partially meshed (network A). If the entire network is viewed as a single subnetwork (with a single network number assigned), most protocols assume that node A can transmit a packet directly to node E, when in fact it must be relayed through nodes C and D. This network can be made to work with certain protocols (for example, IP), but will not work at all with other protocols (for example, AppleTalk) because nodes C and D will not relay the packet out the same interface on which it was received. One way to make this network work fully is to create a fully meshed network (network B), but doing so requires a large number of PVCs, which may not be economically feasible.

Figure 9 *Using Subinterfaces to Provide Full Connectivity on a Partially Meshed Frame Relay Network*

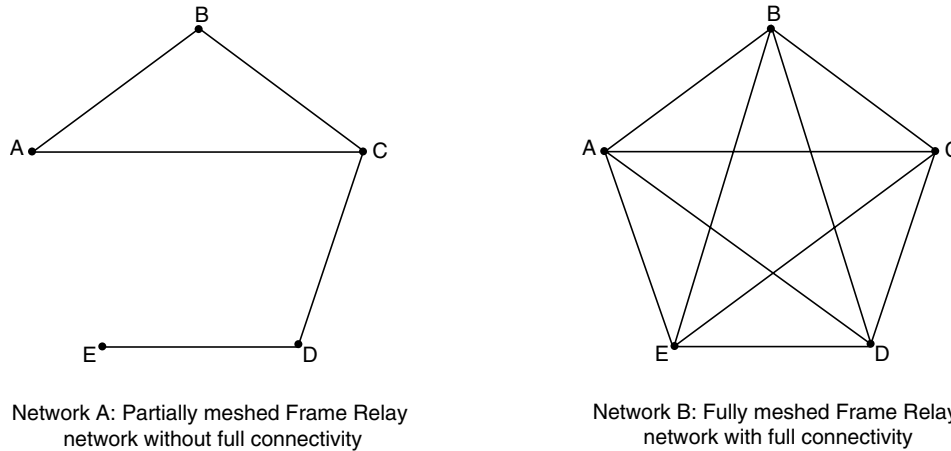

62873

Using subinterfaces, you can subdivide the Frame Relay network into three smaller subnetworks (network C) with separate network numbers. Nodes A, B, and C are connected to a fully meshed network, and nodes C and D, as well as nodes D and E, are connected via point-to-point networks. In this configuration, nodes C and D can access two subinterfaces and can therefore forward packets without violating split horizon rules. If transparent bridging is being used, each subinterface is viewed as a separate bridge port.

Subinterface Addressing

- [Point-to-Point Subinterfaces](#)
- [Addressing on Multipoint Subinterfaces](#)
- [Backup Interface for a Subinterface](#)

Point-to-Point Subinterfaces

For point-to-point subinterfaces, the destination is presumed to be known and is identified or implied in the **frame-relay interface-dlci** command. This command is used to enable routing protocols on main interfaces that are configured to use Inverse ARP. This command is also helpful for assigning a specific class to a single PVC on a multipoint subinterface.

If you define a subinterface for point-to-point communication, you cannot reassign the same subinterface number to be used for multipoint communication without first rebooting the router or access server. Instead, you can simply avoid using that subinterface number and use a different subinterface number.

Addressing on Multipoint Subinterfaces

- [Accepting Inverse ARP for Dynamic Address Mapping on Multipoint Subinterfaces](#)
- [Configuring Static Address Mapping on Multipoint Subinterfaces](#)

Accepting Inverse ARP for Dynamic Address Mapping on Multipoint Subinterfaces

Dynamic address mapping uses Frame Relay Inverse ARP to request the next-hop protocol address for a specific connection, given a DLCI. Responses to Inverse ARP requests are entered in an address-to-DLCI mapping table on the router or access server; the table is then used to supply the next-hop protocol address or the DLCI for outgoing traffic.

Since the physical interface is now configured as multiple subinterfaces, you must provide information that distinguishes a subinterface from the physical interface and associates a specific subinterface with a specific DLCI.

Inverse ARP is enabled by default for all protocols it supports, but can be disabled for specific protocol-DLCI pairs. As a result, you can use dynamic mapping for some protocols and static mapping for other protocols on the same DLCI. You can explicitly disable Inverse ARP for a protocol-DLCI pair if you know the protocol is not supported on the other end of the connection. See the section “[Disabling or Reenabling Frame Relay Inverse ARP](#)” later in this chapter for more information.

Because Inverse ARP is enabled by default for all protocols that it supports, no additional command is required to configure dynamic address mapping on a subinterface.

Configuring Static Address Mapping on Multipoint Subinterfaces

A static map links a specified next-hop protocol address to a specified DLCI. Static mapping removes the need for Inverse ARP requests; when you supply a static map, Inverse ARP is automatically disabled for the specified protocol on the specified DLCI.

You must use static mapping if the router at the other end either does not support Inverse ARP at all or does not support Inverse ARP for a specific protocol that you want to use over Frame Relay.

Backup Interface for a Subinterface

Both point-to-point and multipoint Frame Relay subinterfaces can be configured with a backup interface. This approach allows individual PVCs to be backed up in case of failure rather than depending on the entire Frame Relay connection to fail before the backup takes over. You can configure a subinterface for backup on failure only, not for backup based on loading of the line.

If the main interface has a backup interface, it will have precedence over the subinterface's backup interface in the case of complete loss of connectivity with the Frame Relay network. As a result, a subinterface backup is activated only if the main interface is up, or if the interface is down and does not have a backup interface defined. If a subinterface fails while its backup interface is in use, and the main interface goes down, the backup subinterface remains connected.

Disabling or Reenabling Frame Relay Inverse ARP

Frame Relay Inverse ARP is a method of building dynamic address mappings in Frame Relay networks running AppleTalk, Banyan VINES, DECnet, IP, Novell IPX, and XNS. Inverse ARP allows the router or access server to discover the protocol address of a device associated with the VC.

Inverse ARP creates dynamic address mappings, as contrasted with the **frame-relay map** command, which defines static mappings between a specific protocol address and a specific DLCI.

Inverse ARP is enabled by default but can be disabled explicitly for a given protocol and DLCI pair. Disable or reenables Inverse ARP under the following conditions:

- Disable Inverse ARP for a selected protocol and DLCI pair when you know that the protocol is not supported at the other end of the connection.
- Reenable Inverse ARP for a protocol and DLCI pair if conditions or equipment change and the protocol is then supported at the other end of the connection.

**Note**

If you change from a point-to-point subinterface to a multipoint subinterface, change the subinterface number. Frame Relay Inverse ARP will be on by default, and no further action is required.

You do not need to enable or disable Inverse ARP if you have a point-to-point interface, because there is only a single destination and discovery is not required.

Broadcast Queue for an Interface

Very large Frame Relay networks may have performance problems when many DLCIs terminate in a single router or access server that must replicate routing updates and service advertising updates on each DLCI. The updates can consume access-link bandwidth and cause significant latency variations in user traffic; the updates can also consume interface buffers and lead to higher packet rate loss for both user data and routing updates.

To avoid such problems, you can create a special broadcast queue for an interface. The broadcast queue is managed independently of the normal interface queue, has its own buffers, and has a configurable size and service rate.

A broadcast queue is given a maximum transmission rate (throughput) limit measured in both bytes per second and packets per second. The queue is serviced to ensure that no more than this maximum is provided. The broadcast queue has priority when transmitting at a rate below the configured maximum, and hence has a guaranteed minimum bandwidth allocation. The two transmission rate limits are intended to avoid flooding the interface with broadcasts. The actual transmission rate limit in any second is the first of the two rate limits that is reached.

Frame Relay Fragmentation

Cisco has developed three types of Frame Relay fragmentation, which are described in the following sections:

- [End-to-End FRF.12 Fragmentation](#)
- [Configuring Payload Compression](#)
- [Cisco-Proprietary Fragmentation](#)

The following provides further information about Frame Relay fragmentation:

- [Frame Relay Fragmentation and Hardware Compression Interoperability](#)
- [Frame Relay Fragmentation Conditions and Restrictions](#)

End-to-End FRF.12 Fragmentation

The purpose of end-to-end FRF.12 fragmentation is to support real-time and non-real-time data packets on lower-speed links without causing excessive delay to the real-time data. FRF.12 fragmentation is defined by the FRF.12 Implementation Agreement. This standard was developed to allow long data frames to be fragmented into smaller pieces (fragments) and interleaved with real-time frames. In this way, real-time and non-real-time data frames can be carried together on lower-speed links without causing excessive delay to the real-time traffic.

End-to-end FRF.12 fragmentation is recommended for use on permanent virtual circuits (PVCs) that share links with other PVCs that are transporting voice and on PVCs transporting Voice over IP (VoIP). Although VoIP packets should not be fragmented, they can be interleaved with fragmented packets.

FRF.12 is configured on a per-PVC basis using a Frame Relay map class. The map class can be applied to one or many PVCs. Frame Relay traffic shaping must be enabled on the interface in order for fragmentation to work.



Note

When Frame Relay fragmentation is configured, WFQ or LLQ is mandatory. If a map class is configured for Frame Relay fragmentation and the queueing type on that map class is not WFQ or LLQ, the configured queueing type is automatically overridden by WFQ with the default values. To configure LLQ for Frame Relay, refer to the *Cisco IOS Quality of Service Solutions Configuration Guide*, Release 12.2.

Setting the Fragment Size

Set the fragment size so that voice packets are not fragmented and do not experience a serialization delay greater than 20 ms.

To set the fragment size, the link speed must be taken into account. The fragment size should be larger than the voice packets, but small enough to minimize latency on the voice packets. Turn on fragmentation for low speed links (less than 768 kb/s).

Set the fragment size based on the lowest port speed between the routers. For example, if there is a hub and spoke Frame Relay topology where the hub has a T1 speed and the remote routers have 64 kb/s port speeds, the fragment size needs to be set for the 64 kb/s speed on both routers. Any other PVCs that share the same physical interface need to configure the fragmentation to the size used by the voice PVC.

If the lowest link speed in the path is 64 kb/s, the recommended fragment size (for 10 ms serialization delay) is 80 bytes. If the lowest link speed is 128 kb/s, the recommended fragment size is 160 bytes.

For more information, refer to the “[Fragmentation \(FRF.12\)](#)” section in the *VoIP over Frame Relay with Quality of Service (Fragmentation, Traffic Shaping, LLQ / IP RTP Priority)* document.

Frame Relay Fragmentation Using FRF.11 Annex C

When VoFR (FRF.11) and fragmentation are both configured on a PVC, the Frame Relay fragments are sent in the FRF.11 Annex C format. This fragmentation is used when FRF.11 voice traffic is sent on the PVC, and it uses the FRF.11 Annex C format for data.

With FRF.11, all data packets contain fragmentation headers, regardless of size. This form of fragmentation is not recommended for use with Voice over IP (VoIP).

See the chapter “Configuring Voice over Frame Relay” in the *Cisco IOS Voice, Video, and Fax Configuration Guide* for configuration tasks and examples for Frame Relay fragmentation using FRF.11 Annex C.

Cisco-Proprietary Fragmentation

Cisco-proprietary fragmentation is used on data packets on a PVC that is also used for voice traffic. When the **vofr cisco** command is configured on a DLCI and fragmentation is enabled on a map class, the Cisco 2600 series, 3600 series, and 7200 series routers can interoperate as tandem nodes (but cannot perform call termination) with Cisco MC3810 concentrators running Cisco IOS releases prior to 12.0(3)XG or 12.0(4)T.

To configure Cisco-proprietary voice encapsulation, use the **vofr cisco** command. You must then configure a map class to enable voice traffic on the PVCs.

See the chapter “Configuring Voice over Frame Relay” in the *Cisco IOS Voice, Video, and Fax Configuration Guide* for configuration tasks and examples for Cisco-proprietary fragmentation.

Frame Relay Fragmentation and Hardware Compression Interoperability

FRF.12, FRF.11 Annex C, and Cisco-proprietary fragmentation can be used with FRF.9 or data-stream hardware compression on interfaces and virtual circuits (VCs) using Cisco-proprietary or Internet Engineering Task Force (IETF) encapsulation types.

When payload compression and Frame Relay fragmentation are used at the same time, payload compression is always performed before fragmentation.

Frame Relay fragmentation can be used with the following hardware compression modules:

- Cisco 2600 AIM-COMPR2
- Cisco 3620 and 3640 NM-COMPR
- Cisco 3660 AIM-COMPR4
- Cisco 7200 SA-COMPR

Voice over Frame Relay and Voice over IP packets will not be payload-compressed when Frame Relay fragmentation is configured.



Note

On VCs using IETF encapsulation, FRF.9 hardware and software compression will work with Frame Relay fragmentation but will not work with header compression.

Frame Relay Fragmentation Conditions and Restrictions

When Frame Relay fragmentation is configured, the following conditions and restrictions apply:

- WFQ and LLQ at the PVC level are the only queuing strategies that can be used.
- Frame Relay traffic shaping (FRTS) must be configured to enable Frame Relay fragmentation (except on the Cisco 7500 series routers on which Versatile Interface Processor-Based Distributed FRF.11 and FRF.12 is enabled).
- VoFR frames are never fragmented, regardless of size.

- When end-to-end FRF.12 fragmentation is used, the VoIP packets will not include the FRF.12 header, provided the size of the VoIP packet is smaller than the fragment size configured. However, when FRF.11 Annex C or Cisco-proprietary fragmentations are used, VoIP packets will include the fragmentation header.
- If fragments arrive out of sequence, packets are dropped.

**Note**

Fragmentation is performed after frames are removed from the WFQ.

Payload Compression

- [Packet-by-Packet Payload Compression](#)
- [Standard-Based FRF.9 Compression](#)
- [Cisco-proprietary Data-Stream Compression](#)

Packet-by-Packet Payload Compression

You can configure payload compression on point-to-point or multipoint interfaces or subinterfaces. Payload compression uses the Predictor method to predict what the next character in the frame will be. Because the prediction is done packet by packet, the dictionary is not conserved across packet boundaries. Payload compression on each VC consumes approximately 40 kilobytes for dictionary memory.

Standard-Based FRF.9 Compression

Frame Relay compression can now occur on the VIP board, on the Compression Service Adapter (CSA), or on the main CPU of the router. FRF.9 is standard-based and therefore provides multivendor compatibility. FRF.9 compression uses relatively higher compression ratios, allowing more data to be compressed for faster transmission. FRF.9 compression provides the ability to maintain multiple decompression/compression histories on a per-DLCI basis.

The CSA hardware has been in use on the Cisco 7200 series and Cisco 7500 series platforms, but it has had no support for Frame Relay compression. The CSA can be used in the Cisco 7200 series or in the second-generation Versatile Interface Processor (VIP2) in all Cisco 7500 series routers. The specific VIP2 model required for the CSA is VIP2-40, which has 2 MB of SRAM and 32 MB of DRAM.

Selecting FRF.9 Compression Method

The router enables compression in the following order:

1. If the router contains a compression service adapter, compression is performed in the CSA hardware (hardware compression).
2. If the CSA is not available, compression is performed in the software installed on the VIP2 card (distributed compression).
3. If the VIP2 card is not available, compression is performed in the main processor of the router (software compression).

Cisco-proprietary Data-Stream Compression

Data-stream compression is a proprietary hardware and software compression protocol that can be used on the same VC or interface and IP header compression. Data-stream compression is functionally equivalent to FRF.9 compression and must be used with Cisco-proprietary encapsulation. Frame Relay fragmentation can also be used with data-stream compression.

TCP/IP Header Compression

TCP/IP header compression, as described by RFC 1144, is designed to improve the efficiency of bandwidth utilization over low-speed serial links. A typical TCP/IP packet includes a 40-byte datagram header. Once a connection is established, the header information is redundant and need not be repeated in every packet that is sent. Reconstructing a smaller header that identifies the connection and indicates the fields that have changed and the amount of change reduces the number of bytes transmitted. The average compressed header is 10 bytes long.

For this algorithm to function, packets must arrive in order. If packets arrive out of order, the reconstruction will appear to create regular TCP/IP packets but the packets will not match the original. Because priority queueing changes the order in which packets are transmitted, enabling priority queueing on the interface is not recommended.

**Note**

If you configure an interface with Cisco-proprietary encapsulation and TCP/IP header compression, Frame Relay IP maps inherit the compression characteristics of the interface. However, if you configure the interface with IETF encapsulation, the interface cannot be configured for compression. Frame Relay maps will have to be configured individually to support TCP/IP header compression.

- [Specifying an Individual IP Map for TCP IP Header Compression](#)
- [Specifying an Interface for TCP IP Header Compression](#)

Specifying an Individual IP Map for TCP IP Header Compression

**Note**

An interface configured to support TCP/IP header compression cannot also support priority queueing or custom queueing.

TCP/IP header compression requires Cisco-proprietary encapsulation. If you need to have IETF encapsulation on an interface as a whole, you can still configure a specific IP map to use Cisco-proprietary encapsulation and TCP header compression. In addition, even if you configure the interface to perform TCP/IP header compression, you can still configure a specific IP map not to compress TCP/IP headers.

You can specify whether TCP/IP header compression is active or passive. Active compression subjects every outgoing packet to TCP/IP header compression. Passive compression subjects an outgoing TCP/IP packet to header compression only if a packet had a compressed TCP/IP header when it was received.

Specifying an Interface for TCP/IP Header Compression

You can configure the interface with active or passive TCP/IP header compression. Active compression, the default, subjects all outgoing TCP/IP packets to header compression. Passive compression subjects an outgoing packet to header compression only if the packet had a compressed TCP/IP header when it was received on that interface.

If an interface configured with Cisco-proprietary encapsulation is later configured with IETF encapsulation, all TCP/IP header compression characteristics are lost. To apply TCP/IP header compression over an interface configured with IETF encapsulation, you must configure individual IP maps.

If you configure an interface with Cisco-proprietary encapsulation and TCP/IP header compression, Frame Relay IP maps inherit the compression characteristics of the interface. However, if you configure the interface with IETF encapsulation, the interface cannot be configured for compression. Frame Relay maps will have to be configured individually to support TCP/IP header compression.

Real-Time Header Compression with Frame Relay Encapsulation

Real-time Transport Protocol (RTP) is a protocol used for carrying packetized audio and video traffic over an IP network, providing end-to-end network transport functions intended for these real-time traffic applications and multicast or unicast network services. RTP is described in RFC 1889. RTP is not intended for data traffic, which uses TCP or UDP.

Discard Eligibility

Some Frame Relay packets can be set with low priority or low time sensitivity. These will be the first to be dropped when a Frame Relay switch is congested. The mechanism that allows a Frame Relay switch to identify such packets is the discard eligibility (DE) bit.

Discard eligibility requires the Frame Relay network to be able to interpret the DE bit. Some networks take no action when the DE bit is set, and others use the DE bit to determine which packets to discard. The best interpretation is to use the DE bit to determine which packets should be dropped first and also which packets have lower time sensitivity.

You can create DE lists that identify the characteristics of packets to be eligible for discarding, and you can also specify DE groups to identify the DLCI that is affected.

You can create DE lists based on the protocol or the interface, and on characteristics such as fragmentation of the packet, a specific TCP or User Datagram Protocol (UDP) port, an access list number, or a packet size.

DLCI Priority Levels

DLCI priority levels allow you to separate different types of traffic and provides a traffic management tool for congestion problems caused by following situations:

- Mixing batch and interactive traffic over the same DLCI
- Queueing traffic from sites with high-speed access at destination sites with lower-speed access

Before you configure the DLCI priority levels, you must:

- Define a global priority list.

- Enable Frame Relay encapsulation.
- Define dynamic or static address mapping.
- Make sure that you define each of the DLCIs to which you intend to apply levels. You can associate priority-level DLCIs with subinterfaces.
- Configure the LMI.

**Note**

DLCI priority levels provide a way to define multiple parallel DLCIs for different types of traffic. DLCI priority levels do not assign priority queues within the router or access server. In fact, they are independent of the device's priority queues. However, if you enable queuing and use the same DLCIs for queuing, then high-priority DLCIs can be put into high-priority queues.

How to Configure Frame Relay

- [Enabling Frame Relay Encapsulation on an Interface](#) (Required)
- [Configuring Static Address Mapping](#) (Required)
- [Explicitly Configuring the LMI](#) (Optional)
- [Enabling Frame Relay SVC Service](#) (Optional)
- [Configuring Frame Relay Traffic Shaping](#) (Optional)
- [Configuring Frame Relay Switching](#) (Optional)
- [Customizing Frame Relay for Your Network](#) (Optional)
- [Monitoring and Maintaining the Frame Relay Connections](#) (Optional)

Enabling Frame Relay Encapsulation on an Interface

**Note**

Frame Relay encapsulation is a prerequisite for any Frame Relay commands on an interface.

To enable Frame Relay encapsulation on the interface level, use the following commands beginning in global configuration mode:

	Command	Purpose
Step 1	Router(config)# interface <i>type</i> <i>number</i>	Specifies the interface, and enters interface configuration mode.
Step 2	Router(config-if)# encapsulation frame-relay [<i>ietf</i>]	Enables and specifies the Frame Relay encapsulation method.

Configuring Static Address Mapping

To establish static mapping according to your network needs, use one of the following commands in interface configuration mode:

Command	Purpose
Router(config-if)# frame-relay map <i>protocol protocol-address dlci</i> [broadcast] [ietf] [cisco]	Maps between a next-hop protocol address and DLCI destination address. The supported protocols and the corresponding keywords to enable them are as follows: <ul style="list-style-type: none"> • IP—ip • DECnet—decnet • AppleTalk—appletalk • XNS—xns • Novell IPX—ipx • VINES—vines • ISO CLNS—clns
Router(config-if)# frame-relay map clns <i>dlci</i> [broadcast]	Defines a DLCI used to send ISO CLNS frames.
Router(config-if)# frame-relay map bridge <i>dlci</i> [broadcast] [ietf]	Defines a DLCI destination bridge.

Explicitly Configuring the LMI

- [Setting the LMI Type](#) (Required)
- [Setting the LMI Keepalive Interval](#) (Required)
- [Setting the LMI Polling and Timer Intervals](#) (Optional)

Setting the LMI Type

If the router or access server is attached to a public data network (PDN), the LMI type must match the type used on the public network. Otherwise, the LMI type can be set to suit the needs of your private Frame Relay network. You can set one of the following three types of LMIs on Cisco devices: ANSI T1.617 Annex D, Cisco, and ITU-T Q.933 Annex A. To do so, use the following commands beginning in interface configuration mode:

	Command	Purpose
Step 1	Router(config-if)# frame-relay lmi-type { ansi cisco q933a }	Sets the LMI type.
Step 2	Router# copy nvram:startup-config <i>destination</i>	Writes the LMI type to NVRAM.

Setting the LMI Keepalive Interval

A keepalive interval must be set to configure the LMI. By default, this interval is 10 seconds and, according to the LMI protocol, must be less than the corresponding interval on the switch. To set the keepalive interval, use the following command in interface configuration mode:

Command	Purpose
Router(config-if)# keepalive <i>number</i>	Sets the LMI keepalive interval.

Setting the LMI Polling and Timer Intervals

You can set various optional counters, intervals, and thresholds to fine-tune the operation of your LMI DTE and DCE devices. Set these attributes by using one or more of the following commands in interface configuration mode:

Command	Purpose
Router(config-if)# frame-relay lmi-n392dce threshold	Sets the DCE and Network-to-Network Interface (NNI) error threshold.
Router(config-if)# frame-relay lmi-n393dce events	Sets the DCE and NNI monitored events count.
Router(config-if)# frame-relay lmi-t392dce seconds	Sets the polling verification timer on a DCE or NNI interface.
Router(config-if)# frame-relay lmi-n391dte keep-exchanges	Sets a full status polling interval on a DTE or NNI interface.
Router(config-if)# frame-relay lmi-n392dte threshold	Sets the DTE or NNI error threshold.
Router(config-if)# frame-relay lmi-n393dte events	Sets the DTE and NNI monitored events count.

Enabling Frame Relay SVC Service

- [Configuring SVCs on a Physical Interface](#) (Required)
- [Configuring SVCs on a Subinterface](#) (Optional)
- [Configuring a Map Class](#) (Required)
- [Configuring a Map Group with E.164 or X.121 Addresses](#) (Required)
- [Associating the Map Class with Static Protocol Address Maps](#) (Required)
- [Configuring LAPF Parameters](#) (Optional)

Configuring SVCs on a Physical Interface

To enable SVC operation on a Frame Relay interface, use the following commands beginning in global configuration mode:

	Command	Purpose
Step 1	Router(config)# interface <i>type number</i>	Specifies the physical interface.
Step 2	Router(config-if)# ip address <i>ip-address mask</i>	Specifies the interface IP address, if needed.
Step 3	Router(config-if)# encapsulation frame-relay	Enables Frame Relay encapsulation on the interface.
Step 4	Router(config-if)# map-group <i>group-name</i>	Assigns a map group to the interface. Map group details are specified with the map-list command.
Step 5	Router(config-if)# frame-relay svc	Enables Frame Relay SVC support on the interface.

Configuring SVCs on a Subinterface



Note

This task offers additional flexibility for SVC configuration and operation.

To configure Frame Relay SVCs on a subinterface, complete all the commands in the preceding section, except assigning the map group. After the physical interface is configured, use the following commands beginning in global configuration mode:

	Command	Purpose
Step 1	Router(config)# interface <i>type</i> <i>number.subinterface-number</i> { multipoint point-to-point }	Specifies a subinterface configured for SVC operation.
Step 2	Router(config-subif)# ip address <i>ip-address mask</i>	Specifies the subinterface IP address, if needed.
Step 3	Router(config-subif)# map-group <i>group-name</i>	Assigns a map group to the subinterface.

Configuring a Map Class

Perform the following tasks to configure a map class:

- Specify the map class name. (Required)
- Specify a custom queue list for the map class. (Optional)
- Specify a priority queue list for the map class. (Optional)
- Enable BECN feedback to throttle the output rate on the SVC for the map class. (Optional)
- Set nondefault QoS values for the map class (no need to set the QoS values; default values are provided). (Optional)



Note

You can define multiple map classes. A map class is associated with a static map, not with the interface or subinterface. Because of the flexibility this association allows, you can define different map classes for different destinations.

To configure a map class, use the following commands beginning in global configuration mode:

	Command	Purpose
Step 1	Router(config)# map-class frame-relay <i>map-class-name</i>	Specifies Frame Relay map class name and enters map class configuration mode.
Step 2	Router(config-map-class)# frame-relay custom-queue-list <i>list-number</i>	Specifies a custom queue list to be used for the map class.
Step 3	Router(config-map-class)# frame-relay priority-group <i>list-number</i>	Assigns a priority queue to VCs associated with the map class.
Step 4	Router(config-map-class)# frame-relay adaptive-shaping [becn foresight] ¹	Enables the type of BECN feedback to throttle the frame-transmission rate.
Step 5	Router(config-map-class)# frame-relay cir in <i>bps</i>	Specifies the inbound committed information rate (CIR), in bits per second.
Step 6	Router(config-map-class)# frame-relay cir out <i>bps</i>	Specifies the outbound CIR, in bits per second.
Step 7	Router(config-map-class)# frame-relay mincir in <i>bps</i> ²	Sets the minimum acceptable incoming CIR, in bits per second.
Step 8	Router(config-map-class)# frame-relay mincir out <i>bps</i> ²	Sets the minimum acceptable outgoing CIR, in bits per second.

	Command	Purpose
Step 9	Router(config-map-class)# frame-relay bc in <i>bits</i> ²	Sets the incoming committed burst size (Bc), in bits.
Step 10	Router(config-map-class)# frame-relay bc out <i>bits</i> ²	Sets the outgoing Bc, in bits.
Step 11	Router(config-map-class)# frame-relay be in <i>bits</i> ²	Sets the incoming excess burst size (Be), in bits.
Step 12	Router(config-map-class)# frame-relay be out <i>bits</i> ²	Sets the outgoing Be, in bits.
Step 13	Router(config-map-class)# frame-relay idle-timer <i>seconds</i> ²	Sets the idle timeout interval, in seconds.

1. This command replaces the **frame-relay becn-response-enable** command, which will be removed in a future Cisco IOS release. If you use the **frame-relay becn-response-enable** command in scripts, you should replace it with the **frame-relay adaptive-shaping becn** command.
2. The **in** and **out** keywords are optional. Configuring the command without the **in** and **out** keywords will apply that value to both the incoming and the outgoing traffic values for the SVC setup. For example, **frame-relay cir 56000** applies 56000 to both incoming and outgoing traffic values for setting up the SVC.

Configuring a Map Group with E.164 or X.121 Addresses

After you have defined a map group for an interface, you can associate the map group with a specific source and destination address to be used. You can specify E.164 addresses or X.121 addresses for the source and destination. To specify the map group to be associated with a specific interface, use the following command in global configuration mode:

Command	Purpose
Router(config)# map-list <i>map-group-name</i> source-addr { e164 x121 } source-address dest-addr { e164 x121 } destination-address	Specifies the map group associated with specific source and destination addresses for the SVC.

Associating the Map Class with Static Protocol Address Maps

To define the protocol addresses under a **map-list** command and associate each protocol address with a specified map class, use the **class** command. Use this command for each protocol address to be associated with a map class. To associate a map class with a protocol address, use the following command in map list configuration mode:

Command	Purpose
Router(config-map-list)# protocol protocol-address class <i>class-name</i> [ietf] [broadcast [trigger]]	Specifies a destination protocol address and a Frame Relay map class name from which to derive QoS information. <ul style="list-style-type: none"> • The ietf keyword specifies RFC 1490 encapsulation • The broadcast keyword specifies that broadcasts must be carried. • The trigger keyword, which can be configured only if broadcast is also configured, enables a broadcast packet to trigger an SVC. If an SVC already exists that uses this map class, the SVC will carry the broadcast.

Configuring LAPF Parameters



Note

The LAPF tasks are not required and not recommended unless you understand thoroughly the impacts on your network.

By default, the Frame Reject frame is sent at the LAPF Frame Reject procedure.

Frame Relay Link Access Procedure for Frame Relay (LAPF) commands are used to tune Layer 2 system parameters to work well with the Frame Relay switch. Normally, you do not need to change the default settings. However, if the Frame Relay network indicates that it does not support the Frame Reject frame (FRMR) at the LAPF Frame Reject procedure, use the following command in interface configuration mode:

Command	Purpose
Router(config-if)# no frame-relay lapf frmr	Selects not to send FRMR frames at the LAPF Frame Reject procedure.

Changing Layer 2 Parameters for Your Network



Note

Manipulation of Layer 2 parameters is not recommended if you do not know well the resulting functional change. For more information, refer to the ITU-T Q.922 specification for LAPF.

If you must change Layer 2 parameters for your network environment and you understand the resulting functional change, use the following commands as needed:

Command	Purpose
Router(config-if)# frame-relay lapf k <i>number</i>	Sets the LAPF window size k.
Router(config-if)# frame-relay lapf n200 <i>retries</i>	Sets the LAPF maximum retransmission count N200.
Router(config-if)# frame-relay lapf n201 <i>bytes</i>	Sets maximum length of the Information field of the LAPF I frame N201, in bytes.
Router(config-if)# frame-relay lapf t200 <i>tenths-of-a-second</i>	Sets the LAPF retransmission timer value T200, in tenths of a second.
Router(config-if)# frame-relay lapf t203 <i>seconds</i>	Sets the LAPF link idle timer value T203 of DLCI 0, in seconds.

Configuring Frame Relay Traffic Shaping

- [Enabling Frame Relay Encapsulation on an Interface](#) (earlier in this module)
- [Enabling Frame Relay Traffic Shaping on the Interface](#)
- [Configuring Enhanced Local Management Interface](#)
- [Specifying a Traffic-Shaping Map Class for the Interface](#)
- [Defining a Map Class with Queueing and Traffic-Shaping Parameters](#)

Enabling Frame Relay Traffic Shaping on the Interface

To configure a map class with traffic-shaping and per-VC queuing parameters, see the sections [“Specifying a Traffic-Shaping Map Class for the Interface”](#) and [“Defining a Map Class with Queuing and Traffic-Shaping Parameters”](#).

To enable Frame Relay traffic shaping on the specified interface, use the following command in interface configuration mode:

Command	Purpose
Router(config-if)# frame-relay traffic-shaping	<p>Enables Frame Relay traffic shaping and per-VC queuing.</p> <p>Note The default committed information rate (CIR) of 56K will apply in the following situations: When traffic shaping is enabled (by using the frame-relay traffic-shaping command), but a map class is not assigned to the VC and when traffic shaping is enabled (by using the frame-relay traffic-shaping command) and a map class is assigned to the VC, but traffic-shaping parameters have not been defined in the map class.</p>

Configuring Enhanced Local Management Interface

- [Enabling ELMI](#) (Required)
- [Disabling Automatic IP Address Selection](#) (Optional)
- [Configuring the IP Address to Be Used for ELMI Address Registration](#) (Optional)
- [Enabling ELMI Address Registration on an Interface](#) (Optional)
- [Verifying ELMI Address Registration](#) (Optional)

Enabling ELMI

To enable ELMI, use the following commands beginning in interface configuration mode:

	Command	Purpose
Step 1	Router(config)# interface <i>type number</i>	Specifies the physical interface.
Step 2	Router(config-if)# encapsulation frame-relay [cisco ietf]	Enables Frame Relay encapsulation on the interface.
Step 3	Router(config-if)# frame-relay QoS-autosense	Enables ELMI.

Disabling Automatic IP Address Selection

Automatic IP address selection is enabled by default when ELMI is enabled. To disable the automatic selection of the IP address to be used for ELMI address registration, use the following global configuration command:

Command	Purpose
Router(config)# no frame-relay address registration auto-address	<p>Disables the automatic selection of the IP address to be used for ELMI address registration.</p> <p>Note When automatic IP address selection is disabled and an IP address has not been configured using the frame-relay address registration ip global configuration command, the IP address for ELMI address registration will be set to 0.0.0.0.</p>

Configuring the IP Address to Be Used for ELMI Address Registration

To configure the IP address for ELMI address registration, use the following global configuration command:

Command	Purpose
Router(config)# frame-relay address registration ip <i>address</i>	<p>Configures the IP address to be used for ELMI address registration.</p> <p>Note Automatic IP address selection is disabled when you configure the management IP address using the frame-relay address registration ip global configuration command.</p>

Enabling ELMI Address Registration on an Interface

To enable ELMI address registration on an interface, use the following interface configuration command:

Command	Purpose
Router(config-if)# frame-relay address-reg enable	Enables ELMI address registration on an interface. To disable ELMI address registration on an interface, use the no form of the command.

Verifying ELMI Address Registration

To verify that ELMI address registration is configured correctly, use the following privileged EXEC configuration command:

Command	Purpose
Router# show frame-relay qos-autosense [<i>interface interface</i>]	Displays the QoS values and ELMI address registration information sensed from the switch.

Specifying a Traffic-Shaping Map Class for the Interface

To specify a map class for the specified interface, use the following command beginning in interface configuration mode:

Command	Purpose
Router(config-if)# frame-relay class <i>map-class-name</i>	Specifies a Frame Relay map class for the interface.

Defining a Map Class with Queueing and Traffic-Shaping Parameters

To define a map class, use the following commands beginning in global configuration mode:

	Command	Purpose
Step 1	Router(config)# map-class frame-relay <i>map-class-name</i>	Specifies a map class to define.
Step 2	Router(config-map-class)# frame-relay traffic-rate <i>average [peak]</i>	Defines the traffic rate for the map class.
Step 3	Router(config-map-class)# frame-relay custom-queue-list <i>list-number</i>	Specifies a custom queue list.
Step 4	Router(config-map-class)# frame-relay priority-group <i>list-number</i>	Specifies a priority queue list.
Step 5	Router(config-map-class)# frame-relay adaptive-shaping { <i>becn</i> <i>foresight</i> }	<p>Selects BECN or ForeSight as congestion backward-notification mechanism to which traffic shaping adapts.</p> <p>Note This command replaces the frame-relay becn-response-enable command, which will be removed in a future Cisco IOS release. If you use the frame-relay becn-response-enable command in scripts, you should replace it with the frame-relay adaptive-shaping software command.</p>

Configuring Frame Relay Switching

- [Enabling Frame Relay Switching](#) (Required)
- [Enabling Frame Relay Encapsulation on an Interface](#) (Required)
- [Configuring a Frame Relay DTE Device or DCE Switch or NNI Support](#) (Required)
- [Creating Switched PVC over ISDN](#) (Required)
- [Identifying a PVC As Switched](#) (Optional)
- [Configuring Traffic Policing on UNI DCE Devices](#) (Optional)
- [Configuring Congestion Management on Switched PVCs](#) (Optional)
- [Configuring FRF.12 Fragmentation on Switched PVCs](#) (Optional)
- [Verifying Frame Relay Switching](#) (Optional)
- [Troubleshooting Frame Relay Switching](#) (Optional)

Enabling Frame Relay Switching

You must enable packet switching before you can configure it on a Frame Relay DTE or DCE, or with Network-to-Network Interface (NNI) support. Do so by using the following command in global configuration mode before configuring the switch type:

Command	Purpose
Router(config)# frame-relay switching	Enables Frame Relay switching.

Configuring a Frame Relay DTE Device or DCE Switch or NNI Support

You can configure an interface as a DTE device or a DCE switch, or as a switch connected to a switch to support NNI connections. (DTE is the default.) To do so, use the following command in interface configuration mode:

Command	Purpose
Router(config-if)# frame-relay intf-type [dce dte nni]	Configures a Frame Relay DTE device or DCE switch.

Creating Switched PVC over ISDN

To create a switched PVC over ISDN, or to create a switched PVC on which traffic shaping, traffic policing, and congestion management can be configured, use the following command in global configuration mode:

Command	Purpose
Router(config)# connect <i>connection-name</i> <i>interface dlci</i> <i>interface dlci</i>	Defines connections between Frame Relay PVCs.

Creating a Switched PVC with Static Route



Note

Static routes cannot be configured over tunnel interfaces on the Cisco 800 series, 1600 series, and 1700 series platforms. Static routes can only be configured over tunnel interfaces on platforms that have the Enterprise feature set.

To create a switched PVC with a static route, use the following command in interface configuration mode:

Command	Purpose
Router(config-if)# frame-relay route <i>in-dlci</i> interface <i>out-interface-type</i> <i>out-interface-number</i> <i>out-dlci</i>	Specifies a static route for PVC switching.

Identifying a PVC As Switched

Before you can associate a map class with a switched PVC, you must identify the PVC as being switched. To identify a PVC as switched, use the following command in interface configuration mode:

Command	Purpose
Router(config-if)# frame-relay interface-dlci <i>dlci</i> switched	Identifies a PVC as switched.

Configuring Traffic Policing on UNI DCE Devices

- [Enabling Frame Relay Policing](#)
- [Configuring Frame Relay Policing Parameters](#)

Enabling Frame Relay Policing

To enable Frame Relay policing on a interface, use the following command in interface configuration mode:

Command	Purpose
Router(config-if)# frame-relay policing	Enables Frame Relay policing on all switched PVCs on the interface.

Configuring Frame Relay Policing Parameters

To configure policing parameters in a Frame Relay map class, use one or more of the following commands in map-class configuration mode:

Command	Purpose
Router(config-map-class)# frame-relay cir { in out } <i>bps</i>	Sets the CIR for a Frame Relay PVC, in bits per second.
Router(config-map-class)# frame-relay bc { in out } <i>bits</i>	Sets the committed burst size for a Frame Relay PVC, in bits.
Router(config-map-class)# frame-relay be { in out } <i>bits</i>	Sets the excess burst size for a Frame Relay PVC, in bits.
Router(config-map-class)# frame-relay tc <i>milliseconds</i>	Sets the measurement interval for policing incoming traffic on a PVC when the CIR is zero, in milliseconds.

Configuring Congestion Management on Switched PVCs

- [Configuring Frame Relay Congestion Management on the Interface](#)
- [Configuring Frame Relay Congestion Management on Traffic-Shaping Queues](#)

Configuring Frame Relay Congestion Management on the Interface

To configure Frame Relay congestion management on all switched PVCs on an interface, use the following commands beginning in interface configuration mode:

	Command	Purpose
Step 1	Router(config-if)# frame-relay congestion management	Enables Frame Relay congestion management on all switched PVCs on an interface and enters Frame Relay congestion management configuration mode.
Step 2	Router(config-fr-congest)# threshold de <i>percentage</i>	Configures the threshold at which DE-marked packets will be discarded from switched PVCs on the output interface.
Step 3	Router(config-fr-congest)# threshold ecn { <i>bc</i> <i>be</i> } <i>percentage</i>	Configures the threshold at which ECN bits will be set on packets in switched PVCs on the output interface.

Configuring Frame Relay Congestion Management on Traffic-Shaping Queues

To configure Frame Relay congestion management on the traffic-shaping queues of switched PVCs, use one or more of the following commands in map-class configuration mode:

Command	Purpose
Router(config-map-class)# frame-relay congestion threshold de <i>percentage</i>	Configures the threshold at which DE-marked packets will be discarded from the traffic-shaping queue of a switched PVC.
Router(config-map-class)# frame-relay congestion threshold ecn <i>percentage</i>	Configures the threshold at which ECN bits will be set on packets in the traffic-shaping queue of a switched PVC.
Router(config-map-class)# frame-relay holdq <i>queue-size</i>	Configures the maximum size of a traffic-shaping queue on a switched PVC.

Configuring FRF.12 Fragmentation on Switched PVCs

To configure FRF.12 on switched PVCs, use the following map-class configuration command. The map class can be associated with one or more switched PVCs.

Command	Purpose
Router(config-map-class)# frame-relay fragment <i>fragment_size</i> switched	Enables FRF.12 fragmentation on switched Frame Relay PVCs for a Frame Relay map class.

Verifying Frame Relay Switching

To verify the correct configuration of Frame Relay switching, use one or more of the following commands:

Command	Purpose
Router# show frame-relay fragment [<i>interface interface</i>] [<i>dlci</i>]	Displays statistics about Frame Relay fragmentation.
Router# show frame-relay pvc [<i>interface interface</i>] [<i>dlci</i>]	Displays statistics about Frame Relay PVCs including detailed reasons for packet drops on switched PVCs and complete status information for switched NNI PVCs.
Router# show interfaces [<i>type number</i>]	Displays information about the configuration and queue at the interface.

Troubleshooting Frame Relay Switching

To diagnose problems in switched Frame Relay networks, use the following EXEC commands:

Command	Purpose
Router# debug frame-relay switching [<i>interface interface</i>] [<i>dlci</i>] [<i>interval seconds</i>]	Displays debug messages for switched Frame Relay PVCs. The interval keyword and <i>seconds</i> argument sets the interval at which the debug messages will be displayed.
Router# show frame-relay pvc [<i>interface interface</i>] [<i>dlci</i>]	Displays statistics about Frame Relay PVCs, including detailed reasons for packet drops on switched PVCs and complete status information for switched NNI PVCs.

Customizing Frame Relay for Your Network

- [Configuring Frame Relay End-to-End Keepalives](#)
- [Enabling PPP over Frame Relay](#)
- [Configuring Frame Relay Subinterfaces](#)
- [Disabling or Reenabling Frame Relay Inverse ARP](#)
- [Creating a Broadcast Queue for an Interface](#)
- [Configuring Frame Relay Fragmentation](#)
- [Configuring Payload Compression](#)
- [Configuring TCP/IP Header Compression](#)
- [Configuring Discard Eligibility](#)
- [Configuring DLCI Priority Levels](#)

Configuring Frame Relay End-to-End Keepalives

- [Configuring End-to-End Keepalives](#)
- [Modifying the Default Parameters](#)
- [Verifying Frame Relay End-to-End Keepalives](#)

Configuring End-to-End Keepalives

To configure Frame Relay end-to-end keepalives, use the following commands beginning in global configuration mode:

	Command	Purpose
Step 1	Router(config)# map-class frame-relay <i>map-class-name</i>	Specifies a map class for the VC.
Step 2	Router(config-map-class)# frame-relay end-to-end keepalive mode { bidirectional request reply passive-reply }	Specifies Frame Relay end-to-end keepalive mode. <ul style="list-style-type: none"> • bidirectional—The device sends keepalive requests to the other end of the VC and responds to keepalive requests from the other end of the VC. • request—The device sends keepalive requests to the other end of the VC. • reply—The device responds to keepalive requests from the other end of the VC. • passive-reply—The device responds to keepalive requests from the other end of the VC, but will not track errors or successes.

Modifying the Default Parameters

You can modify the end-to-end keepalives default parameter values by using any of the following map-class configuration commands:

Command	Purpose
Router(config-map-class)# frame-relay end-to-end keepalive error-threshold { send receive } <i>count</i>	Modifies the number of errors needed to change the keepalive state from up to down.
Router(config-map-class)# frame-relay end-to-end keepalive event-window { send receive } <i>count</i>	Modifies the number of recent events to be checked for errors.
Router(config-map-class)# frame-relay end-to-end keepalive success-events { send receive } <i>count</i>	Modifies the number of consecutive success events required to change the keepalive state from down to up.
Router(config-map-class)# frame-relay end-to-end keepalive timer { send receive } <i>interval</i>	Modifies the timer interval.

Verifying Frame Relay End-to-End Keepalives

To monitor the status of Frame Relay end-to-end keepalives, use the following command in EXEC configuration mode:

Command	Purpose
Router# show frame-relay end-to-end keepalive <i>interface</i>	Shows the status of Frame Relay end-to-end keepalives.

Enabling PPP over Frame Relay

To configure the physical interface that will carry the PPP session and link it to the appropriate virtual template interface, perform the following task in interface configuration mode:

Command	Purpose
Router(config-if)# frame-relay interface-dlci <i>dlci</i> [ppp <i>virtual-template-name</i>]	Defines the PVC and maps it to the virtual template.

For an example of configuring PPP over Frame Relay, see the section “[Example: PPP over Frame Relay](#)” or “[Example: PPP over Frame Relay DCE](#)” later in this chapter.

Configuring Frame Relay Subinterfaces

- [Configuring Subinterfaces](#) (Required)
- [Defining Subinterface Addressing on Point-to-Point Subinterfaces](#)
- [Accepting Inverse ARP for Dynamic Address Mapping on Multipoint Subinterfaces](#)
- [Configuring Static Address Mapping on Multipoint Subinterfaces](#)
- [Configuring Transparent Bridging for Point-to-Point Subinterfaces](#) (Optional)
- [Configuring Transparent Bridging for Point-to-Multipoint Interfaces](#)
- [Configuring a Backup Interface for a Subinterface](#) (Optional)

Configuring Subinterfaces

Subinterfaces can be configured for multipoint or point-to-point communication. (There is no default.) To configure subinterfaces on a Frame Relay network, use the following commands beginning in global configuration mode:

	Command	Purpose
Step 1	Router(config)# interface <i>type</i> <i>number.subinterface-number</i> { multipoint point-to-point }	Creates a point-to-point or multipoint subinterface.
Step 2	Router(config-subif)# encapsulation frame-relay	Configures Frame Relay encapsulation on the serial interface.

Defining Subinterface Addressing on Point-to-Point Subinterfaces

If you specified a point-to-point subinterface in the preceding procedure, use the following command in subinterface configuration mode:

Command	Purpose
Router(config-subif)# frame-relay interface-dlci <i>dlci</i>	Associates the selected point-to-point subinterface with a DLCI.

Accepting Inverse ARP for Dynamic Address Mapping on Multipoint Subinterfaces

To associate a specific multipoint subinterface with a specific DLCI, use the following command in interface configuration mode:

Command	Purpose
Router(config-if)# frame-relay interface-dlci <i>dlci</i>	Associates a specified multipoint subinterface with a DLCI.

Configuring Static Address Mapping on Multipoint Subinterfaces

To establish static mapping according to your network needs, use one of the following commands in interface configuration mode:

Command	Purpose
Router(config-if)# frame-relay map <i>protocol protocol-address dlci</i> [broadcast] [ietf] [cisco]	Maps between a next-hop protocol address and DLCI destination address. The supported protocols and the corresponding keywords to enable them are as follows: <ul style="list-style-type: none"> • IP—ip • DECnet—decnet • AppleTalk—appletalk • XNS—xns • Novell IPX—ipx • VINES—vines • ISO CLNS—clns
Router(config-if)# frame-relay map clns <i>dlci</i> [broadcast]	Defines a DLCI used to send ISO CLNS frames. The broadcast keyword is required for routing protocols such as OSI protocols and the Open Shortest Path First (OSPF) protocol.
Router(config-if)# frame-relay map bridge <i>dlci</i> [broadcast] [ietf]	Defines a DLCI destination bridge.

Configuring Transparent Bridging for Point-to-Point Subinterfaces



Note

All PVCs configured on a subinterface belong to the same bridge group.

To configure transparent bridging for point-to-point subinterfaces, use the following commands beginning in global configuration mode:

	Command	Purpose
Step 1	Router(config)# interface type <i>number</i>	Specifies an interface.
Step 2	Router(config-if)# encapsulation frame-relay	Configures Frame Relay encapsulation on the interface.
Step 3	Router(config)# interface type <i>number:subinterface-number</i> point-to-point	Specifies a subinterface.
Step 4	Router(config-subif)# frame-relay interface-dlci <i>dlci</i>	Associates a DLCI with the subinterface.
Step 5	Router(config-subif)# bridge-group <i>bridge-group</i>	Associates the subinterface with a bridge group.

Configuring Transparent Bridging for Point-to-Multipoint Interfaces



Note

All PVCs configured on a subinterface belong to the same bridge group.

To configure transparent bridging for point-to-multipoint subinterfaces, use the following commands beginning in global configuration mode:

	Command	Purpose
Step 1	Router(config)# interface type <i>number</i>	Specifies an interface.
Step 2	Router(config-if)# encapsulation frame-relay	Configures Frame Relay encapsulation.
Step 3	Router(config)# interface type <i>number:subinterface-number</i> multipoint	Specifies a subinterface.
Step 4	Router(config-subif)# frame-relay map bridge <i>dlci</i> [broadcast] [ietf]	Defines a DLCI destination bridge.
Step 5	Router(config-subif)# bridge-group <i>bridge-group</i>	Associates the subinterface with a bridge group.

Configuring a Backup Interface for a Subinterface

To configure a backup interface for a Frame Relay subinterface, use the following commands beginning in global configuration mode:

	Command	Purpose
Step 1	Router(config)# interface type <i>number</i>	Specifies the interface.
Step 2	Router(config-if)# encapsulation frame-relay	Configures Frame Relay encapsulation.
Step 3	Router(config)# interface type <i>number.subinterface-number</i> point-to-point	Configures the subinterface.
Step 4	Router(config-subif)# frame-relay interface-dlci <i>dlci</i>	Specifies DLCI for the subinterface.
Step 5	Router(config-subif)# backup interface type <i>number</i>	Configures backup interface for the subinterface.
Step 6	Router(config-subif)# backup delay <i>enable-delay</i> <i>disable-delay</i>	Specifies backup enable and disable delay.

Disabling or Reenabling Frame Relay Inverse ARP

To select or disable Inverse ARP, use one of the following commands:

Command	Purpose
Router(config-subif)# frame-relay inverse-arp <i>protocol dlc</i>	Enables Frame Relay Inverse ARP for a specific protocol and DLCI pair, only if it was previously disabled.
Router(config-subif)# no frame-relay inverse-arp <i>protocol dlc</i>	Disables Frame Relay Inverse ARP for a specific protocol and DLCI pair.

Creating a Broadcast Queue for an Interface

To create a broadcast queue, use the following command in interface configuration mode:

Command	Purpose
Router(config-if)# frame-relay broadcast-queue <i>size byte-rate packet-rate</i>	Creates a broadcast queue for an interface.

Configuring Frame Relay Fragmentation

- [Configuring End-to-End FRF.12 Fragmentation](#) (Required)
- [Verifying the Configuration of End-to-End FRF.12 Fragmentation](#) (Optional)

Configuring End-to-End FRF.12 Fragmentation

To configure FRF.12 fragmentation in a Frame Relay map class, use the following commands beginning in global configuration mode:

Command	Purpose
Router(config)# map-class frame-relay <i>map-class-name</i>	Specifies a map class to define QoS values for a Frame Relay SVC or PVC. The map class can be applied to one or many PVCs.
Router(config-map-class)# frame-relay fragment <i>fragment_size</i>	Configures Frame Relay fragmentation for the map class. The <i>fragment_size</i> argument defines the payload size of a fragment; it excludes the Frame Relay headers and any Frame Relay fragmentation header. The valid range is from 16 to 1600 bytes, and the default is 53.

Verifying the Configuration of End-to-End FRF.12 Fragmentation

To verify FRF.12 fragmentation, use one or more of the following EXEC commands:

Command	Purpose
Router# show frame-relay fragment [<i>interface interface</i>] [<i>dlci</i>]	Displays Frame Relay fragmentation information.
Router# show frame-relay pvc [<i>interface interface</i>] [<i>dlci</i>]	Displays statistics about PVCs for Frame Relay interfaces.

Configuring Payload Compression

- [Configuring Payload Compression On a Multipoint Interface or Subinterface](#)
- [Configuring Payload Compression On a Point-to-Point Interface or Subinterface](#)
- [Configuring FRF.9 Compression Using Map Statements](#)
- [Configuring FRF.9 Compression on the Subinterface](#)
- [Configuring Data-Stream Hardware Compression and IP Header Compression on a Point-to-Point Subinterface](#)
- [Configuring Data-Stream Hardware Compression and IP Header Compression on a Multipoint Subinterface](#)
- [Verifying Payload Compression](#)

Configuring Payload Compression On a Multipoint Interface or Subinterface

To configure payload compression on a specified multipoint interface or subinterface, use the following command in interface configuration mode:

Command	Purpose
Router(config-if)# frame-relay map <i>protocol protocol-address dlci</i> payload-compression packet-by-packet	Enables payload compression on a multipoint interface.

Configuring Payload Compression On a Point-to-Point Interface or Subinterface

To configure payload compression on a specified point-to-point interface or subinterface, use the following command in interface configuration mode:

Command	Purpose
Router(config-if)# frame-relay payload-compression packet-by-packet	Enables payload compression on a point-to-point interface.

Configuring FRF.9 Compression Using Map Statements

You can control where you want compression to occur by specifying an interface. To enable FRF.9 compression on a specific CSA, VIP CPU, or host CPU, use the following commands beginning in global configuration mode:

	Command	Purpose
Step 1	Router(config)# interface <i>type number</i>	Specifies the interface.
Step 2	Router(config-if)# encapsulation frame-relay	Specifies Frame Relay as encapsulation type.
Step 3	Router(config-if)# frame-relay map payload-compression frf9 stac [<i>hardware-options</i>]	Enables FRF.9 compression.

Configuring FRF.9 Compression on the Subinterface

To configure FRF.9 compression on the subinterface, use the following commands beginning in global configuration mode:

	Command	Purpose
Step 1	Router(config)# interface <i>type number</i>	Specifies the subinterface type and number.
Step 2	Router(config-subif)# encapsulation frame-relay	Specifies Frame Relay as encapsulation type.
Step 3	Router(config-subif)# frame-relay payload-compression frf9 stac [<i>hardware-options</i>]	Enables FRF.9 compression.

Configuring Data-Stream Hardware Compression and IP Header Compression on a Point-to-Point Subinterface

To configure data-stream hardware compression and TCP or Real-Time Transport Protocol (RTP) header compression on a point-to-point subinterface, use the following commands beginning in global configuration mode. Note that when you specify data-stream hardware compression, Cisco-proprietary encapsulation is automatically enabled.

	Command	Purpose
Step 1	Router(config)# interface <i>type number</i> point-to-point	Configures a subinterface type and enters subinterface configuration mode.
Step 2	Router(config-subif)# ip address <i>address mask</i>	Sets the IP address for an interface.
Step 3	Router(config-subif)# frame-relay interface-dlci <i>dlci</i>	Assigns a DLCI to a specified Frame Relay subinterface on the router or access server.
Step 4	Router(config-subif)# frame-relay payload-compression data-stream stac [<i>hardware-options</i>]	Enables hardware compression on an interface or subinterface that uses Cisco-proprietary encapsulation.
Step 5	Router(config-subif)# frame-relay ip tcp header-compression [<i>passive</i>]	Configures an interface to ensure that the associated PVCs carry outgoing TCP headers in compressed form.
	or	
	Router(config-subif)# frame-relay ip rtp header-compression [<i>passive</i>]	Enables RTP header compression on the physical interface.

Configuring Data-Stream Hardware Compression and IP Header Compression on a Multipoint Subinterface

To configure data-stream hardware compression and TCP or RTP header compression on a multipoint subinterface, use the following commands beginning in global configuration mode. Note that when you specify data-stream hardware compression, Cisco-proprietary encapsulation is automatically enabled.

	Command	Purpose
Step 1	Router(config)# interface <i>type number multipoint</i>	Configures a subinterface type and enters subinterface configuration mode.
Step 2	Router(config-subif)# frame-relay interface-dlci <i>dlci</i>	Assigns a DLCI to a specified Frame Relay subinterface on the router or access server.
Step 3	Router(config-subif)# frame-relay map <i>protocol protocol-address dlci [payload-compression data-stream stac [hardware-options]]</i>	Defines the mapping between a destination protocol address and the DLCI used to connect to the destination address on an interface that uses Cisco-proprietary encapsulation.
Step 4	Router(config-subif)# frame-relay ip tcp header-compression [<i>passive</i>] or Router(config-subif)# frame-relay ip rtp header-compression [<i>passive</i>]	Configures an interface to ensure that the associated PVCs carry outgoing TCP headers in compressed form. Enables RTP header compression on the physical interface.

Verifying Payload Compression

To verify that payload compression is working correctly, use the following privileged EXEC commands:

Command	Purpose
Router# show compress	Displays compression statistics.
Router# show frame-relay pvc <i>dlci</i>	Displays statistics about PVCs for Frame Relay interfaces, including the number of packets in the post-hardware-compression queue.
Router# show traffic-shape queue	Displays information about the elements queued at a particular time at the DLCI level, including the number of packets in the post-hardware-compression queue.

Configuring TCP/IP Header Compression

- [Configuring an Individual IP Map for TCP/IP Header Compression](#)
- [Configuring an Interface for TCP/IP Header Compression](#)
- [Disabling TCP/IP Header Compression](#)

Configuring an Individual IP Map for TCP/IP Header Compression

To configure an IP map to use Cisco-proprietary encapsulation and TCP/IP header compression, use the following command in interface configuration mode:

Command	Purpose
Router(config-if)# frame-relay map ip <i>ip-address</i> <i>dlci</i> [broadcast] tcp header-compression [active passive] [connections <i>number</i>]	Configures an IP map to use TCP/IP header compression. Cisco-proprietary encapsulation is enabled by default.

Configuring an Interface for TCP/IP Header Compression

To apply TCP/IP header compression to an interface, you must use the following commands in interface configuration mode:

	Command	Purpose
Step 1	Router(config-if)# encapsulation frame-relay	Configures Cisco-proprietary encapsulation on the interface.
Step 2	Router(config-if)# frame-relay ip tcp header-compression [passive]	Enables TCP/IP header compression.

Disabling TCP/IP Header Compression

You can disable TCP/IP header compression by using either of two commands that have different effects, depending on whether Frame Relay IP maps have been explicitly configured for TCP/IP header compression or have inherited their compression characteristics from the interface.

Frame Relay IP maps that have explicitly configured TCP/IP header compression must also have TCP/IP header compression explicitly disabled.

To disable TCP/IP header compression, use one of the following commands in interface configuration mode:

Command	Purpose
Router(config-if)# no frame-relay ip tcp header-compression	Disables TCP/IP header compression on all Frame Relay IP maps that are not explicitly configured for TCP header compression.
or Router(config-if)# frame-relay map ip <i>ip-address</i> <i>dlci</i> nocompress	Disables RTP and TCP/IP header compression on a specified Frame Relay IP map.

Configuring Discard Eligibility

- [Defining a DE List](#)
- [Defining a DE Group](#)

Defining a DE List

To define a DE list specifying the packets that can be dropped when the Frame Relay switch is congested, use the following command in global configuration mode:

Command	Purpose
Router(config)# frame-relay de-list <i>list-number</i> { protocol <i>protocol</i> interface <i>type number</i> } <i>characteristic</i>	Defines a DE list.

Defining a DE Group

To define a DE group specifying the DE list and DLCI affected, use the following command in interface configuration mode:

Command	Purpose
Router(config-if)# frame-relay de-group <i>group-number dlci</i>	Defines a DE group.

Configuring DLCI Priority Levels

To configure DLCI priority levels, use the following command in interface configuration mode:

Command	Purpose
Router(config-if)# frame-relay priority-dlci-group <i>group-number high-dlci medium-dlci normal-dlci low-dlci</i>	<p>Enables multiple parallel DLCIs for different Frame Relay traffic types; associates and sets level of specified DLCIs with same group.</p> <p>Note If you do not explicitly specify a DLCI for each of the priority levels, the last DLCI specified in the command line is used as the value of the remaining arguments. At a minimum, you must configure the high-priority and the medium-priority DLCIs.</p>

Monitoring and Maintaining the Frame Relay Connections

To monitor Frame Relay connections, use any of the following commands in EXEC mode:

Command	Purpose
Router# clear frame-relay-inarp	Clears dynamically created Frame Relay maps, which are created by the use of Inverse ARP.
Router# show interfaces serial <i>type number</i>	Displays information about Frame Relay DLCIs and the LMI.
Router# show frame-relay lmi [<i>type number</i>]	Displays LMI statistics.
Router# show frame-relay map	Displays the current Frame Relay map entries.
Router# show frame-relay pvc [<i>type number [dlci]</i>]	Displays PVC statistics.
Router# show frame-relay route	Displays configured static routes.
Router# show frame-relay traffic	Displays Frame Relay traffic statistics.
Router# show frame-relay lapf	Displays information about the status of LAPF.
Router# show frame-relay svc maplist	Displays all the SVCs under a specified map list.

Configuration Examples for Frame Relay

- [Example: IETF Encapsulation](#)
- [Example: Static Address Mapping](#)
- [Example: Subinterface](#)
- [Example: SVC Configuration](#)
- [Example: Frame Relay Traffic Shaping](#)
- [Example: Backward Compatibility](#)
- [Example: Booting from a Network Server over Frame Relay](#)
- [Example: Frame Relay Switching](#)
- [Example: Frame Relay End-to-End Keepalive](#)
- [Example: PPP over Frame Relay](#)
- [Example: Frame Relay Fragmentation Configuration](#)
- [Example: Payload Compression Configuration](#)
- [Example: TCP IP Header Compression](#)

Example: IETF Encapsulation

- [Example: IETF Encapsulation on the Interface](#)
- [Example: IETF Encapsulation on a Per-DLCI Basis](#)

Example: IETF Encapsulation on the Interface

The following example sets IETF encapsulation at the interface level. The keyword **ietf** sets the default encapsulation method for all maps to IETF.

```
encapsulation frame-relay ietf
frame-relay map ip 131.108.123.2 48 broadcast
frame-relay map ip 131.108.123.3 49 broadcast
```

Example: IETF Encapsulation on a Per-DLCI Basis

The following example configures IETF encapsulation on a per-DLCI basis. This configuration has the same result as the configuration in the first example.

```
encapsulation frame-relay
frame-relay map ip 131.108.123.2 48 broadcast ietf
frame-relay map ip 131.108.123.3 49 broadcast ietf
```

Example: Static Address Mapping

- [Example: Two Routers in Static Mode](#)
- [Example: AppleTalk Routing](#)
- [Example: DECnet Routing](#)

- [Example: IPX Routing](#)

Example: Two Routers in Static Mode

The following example shows how to configure two routers for static mode:

Configuration for Router 1

```
interface serial 0
 ip address 131.108.64.2 255.255.255.0
 encapsulation frame-relay
 keepalive 10
 frame-relay map ip 131.108.64.1 43
```

Configuration for Router 2

```
interface serial 0
 ip address 131.108.64.1 255.255.255.0
 encapsulation frame-relay
 keepalive 10
 frame-relay map ip 131.108.64.2 43
```

Example: AppleTalk Routing

The following example shows how to configure two routers to communicate with each other using AppleTalk over a Frame Relay network. Each router has a Frame Relay static address map for the other router. The use of the **appletalk cable-range** command indicates that this is extended AppleTalk (Phase II).

Configuration for Router 1

```
interface serial0
 ip address 172.21.59.24 255.255.255.0
 encapsulation frame-relay
 appletalk cable-range 10-20 18.47
 appletalk zone eng
 frame-relay map appletalk 18.225 100 broadcast
```

Configuration for Router 2

```
interface serial2/3
 ip address 172.21.177.18 255.255.255.0
 encapsulation frame-relay
 appletalk cable-range 10-20 18.225
 appletalk zone eng
 clockrate 2000000
 frame-relay map appletalk 18.47 100 broadcast
```

Example: DECnet Routing

The following example sends all DECnet packets destined for address 56.4 out on DLCI 101. In addition, any DECnet broadcasts for interface serial 1 will be sent on that DLCI.

```
decnet routing 32.6
!
interface serial 1
 encapsulation frame-relay
 frame-relay map decnet 56.4 101 broadcast
```

Example: IPX Routing

The following example shows how to send packets destined for IPX address 200.0000.0c00.7b21 out on DLCI 102:

```
ipx routing 000.0c00.7b3b
!
interface ethernet 0
 ipx network 2abc
!
interface serial 0
 ipx network 200
 encapsulation frame-relay
 frame-relay map ipx 200.0000.0c00.7b21 102 broadcast
```

Example: Subinterface

- [Example: Basic Subinterface](#)
- [Example: Frame Relay Multipoint Subinterface with Dynamic Addressing](#)
- [Example: IPX Routes over Frame Relay Subinterfaces](#)
- [Example: Unnumbered IP over a Point-to-Point Subinterface](#)
- [Example: Transparent Bridging Using Subinterfaces](#)

Example: Basic Subinterface

In the following example, subinterface 1 is configured as a point-to-point subnet and subinterface 2 is configured as a multipoint subnet.

```
interface serial 0
 encapsulation frame-relay
interface serial 0.1 point-to-point
 ip address 10.0.1.1 255.255.255.0
 frame-relay interface-dlci 42
!
interface serial 0.2 multipoint
 ip address 10.0.2.1 255.255.255.0
 frame-relay map ip 10.0.2.2 18
```

Example: Frame Relay Multipoint Subinterface with Dynamic Addressing

The following example configures two multipoint subinterfaces for dynamic address resolution. Each subinterface is provided with an individual protocol address and subnet mask, and the **frame-relay interface-dlci** command associates the subinterface with a specified DLCI. Addresses of remote destinations for each multipoint subinterface will be resolved dynamically.

```
interface serial0
 no ip address
 encapsulation frame-relay
 frame-relay lmi-type ansi
!
interface serial0.103 multipoint
 ip address 172.21.177.18 255.255.255.0
 frame-relay interface-dlci 300
!
interface serial0.104 multipoint
```

```
ip address 172.21.178.18 255.255.255.0
frame-relay interface-dlci 400
```

Example: IPX Routes over Frame Relay Subinterfaces

The following example configures a serial interface for Frame Relay encapsulation and sets up multiple IPX virtual networks corresponding to Frame Relay subinterfaces:

```
ipx routing 0000.0c02.5f4f
!
interface serial 0
 encapsulation frame-relay
 interface serial 0.1 multipoint
 ipx network 1
 frame-relay map ipx 1.000.0c07.d530 200 broadcast
 interface serial 0.2 multipoint
 ipx network 2
 frame-relay map ipx 2.000.0c07.d530 300 broadcast
```

For subinterface serial 0.1, the router at the other end might be configured as follows:

```
ipx routing
interface serial 2 multipoint
 ipx network 1
 frame-relay map ipx 1.000.0c02.5f4f 200 broadcast
```

Example: Unnumbered IP over a Point-to-Point Subinterface

The following example sets up unnumbered IP over subinterfaces at both ends of a point-to-point connection. In this example, router A functions as the DTE, and router B functions as the DCE. Routers A and B are both attached to Token Ring networks.

Configuration for Router A

```
interface token-ring 0
 ip address 131.108.177.1 255.255.255.0
!
interface serial 0
 no ip address
 encapsulation frame-relay IETF
!
interface serial0.2 point-to-point
 ip unnumbered TokenRing0
 ip pim sparse-mode
 frame-relay interface-dlci 20
```

Configuration for Router B

```
frame-relay switching
!
interface token-ring 0
 ip address 131.108.178.1 255.255.255.0
!
interface serial 0
 no ip address
 encapsulation frame-relay IETF
 bandwidth 384
 clockrate 4000000
 frame-relay intf-type dce
!
interface serial 0.2 point-to-point
```

```
ip unnumbered TokenRing1
ip pim sparse-mode
!
bandwidth 384
frame-relay interface-dlci 20
```

Example: Transparent Bridging Using Subinterfaces

The following example shows Frame Relay DLCIs 42, 64, and 73 as separate point-to-point links with transparent bridging running over them. The bridging spanning tree views each PVC as a separate bridge port, and a frame arriving on the PVC can be relayed back out on a separate PVC.

```
interface serial 0
 encapsulation frame-relay
interface serial 0.1 point-to-point
 bridge-group 1
 frame-relay interface-dlci 42
interface serial 0.2 point-to-point
 bridge-group 1
 frame-relay interface-dlci 64
interface serial 0.3 point-to-point
 bridge-group 1
 frame-relay interface-dlci 73
```

Example: SVC Configuration

- [Example: SVC Interface](#)
- [Example: SVC Subinterface](#)

Example: SVC Interface

The following example configures a physical interface, applies a map group to the physical interface, and then defines the map group:

```
interface serial 0
 ip address 172.10.8.6
 encapsulation frame-relay
 map-group bermuda
 frame-relay lmi-type q933a
 frame-relay svc
!
map-list bermuda source-addr E164 123456 dest-addr E164 654321
 ip 131.108.177.100 class hawaii
 appletalk 1000.2 class rainbow
!
map-class frame-relay rainbow
 frame-relay idle-timer 60
!
map-class frame-relay hawaii
 frame-relay cir in 64000
 frame-relay cir out 64000
```

Example: SVC Subinterface

The following example configures a point-to-point interface for SVC operation. It assumes that the main serial 0 interface has been configured for signalling and that SVC operation has been enabled on the main interface:

```
int s 0.1 point-point
! Define the map-group; details are specified under the map-list holiday command.
map-group holiday
!
! Associate the map-group with a specific source and destination.
map-list holiday local-addr X121 <X121-addr> dest-addr E164 <E164-addr>
! Specify destination protocol addresses for a map-class.
ip 131.108.177.100 class hawaii IETF
  appletalk 1000.2 class rainbow IETF broadcast
!
! Define a map class and its QoS settings.
map-class hawaii
  frame-relay cir in 2000000
  frame-relay cir out 56000
  frame-relay be 9000
!
! Define another map class and its QoS settings.
map-class rainbow
  frame-relay cir in 64000
  frame-relay idle-timer 2000
```

Example: Frame Relay Traffic Shaping

- [Example: Traffic Shaping with Three Point-to-Point Subinterfaces](#)
- [Example: Traffic Shaping with ForeSight](#)
- [Example: LMI Configuration](#)

Example: Traffic Shaping with Three Point-to-Point Subinterfaces

In the following example, VCs on subinterfaces Serial0.1 and Serial0.2 inherit class parameters from the main interface—namely, those defined in the map class “slow_vcs”—but the VC defined on subinterface Serial0.2 (DLCI 102) is specifically configured to use map class “fast_vcs”.

Map class “slow_vcs” uses a peak rate of 9600 and average rate of 4800 bps. Because BECN feedback is enabled, the output rate will be cut back to as low as 2400 bps in response to received BECNs. This map class is configured to use custom queueing using queue-list 1. In this example, queue-list 1 has 3 queues, with the first two being controlled by access lists 100 and 115.

Map class “fast_vcs” uses a peak rate of 64000 and average rate of 16000 bps. Because BECN feedback is enabled, the output rate will be cut back to as low as 8000 bps in response to received BECNs. This map class is configured to use priority-queueing using priority-group 2.

```
interface serial0
  no ip address
  encapsulation frame-relay
  frame-relay lmi-type ansi
  frame-relay traffic-shaping
  frame-relay class slow_vcs
!
interface serial0.1 point-to-point
  ip address 10.128.30.1 255.255.255.248
  ip ospf cost 200
```

```

bandwidth 10
frame-relay interface-dlci 101
!
interface serial0.2 point-to-point
ip address 10.128.30.9 255.255.255.248
ip ospf cost 400
bandwidth 10
frame-relay interface-dlci 102
class fast_vcs
!
interface serial0.3 point-to-point
ip address 10.128.30.17 255.255.255.248
ip ospf cost 200
bandwidth 10
frame-relay interface-dlci 103
!
map-class frame-relay slow_vcs
frame-relay traffic-rate 4800 9600
frame-relay custom-queue-list 1
frame-relay adaptive-shaping becn
!
map-class frame-relay fast_vcs
frame-relay traffic-rate 16000 64000
frame-relay priority-group 2
frame-relay adaptive-shaping becn
!
access-list 100 permit tcp any any eq 2065
access-list 115 permit tcp any any eq 256
!
priority-list 2 protocol decnet high
priority-list 2 ip normal
priority-list 2 default medium
!
queue-list 1 protocol ip 1 list 100
queue-list 1 protocol ip 2 list 115
queue-list 1 default 3
queue-list 1 queue 1 byte-count 1600 limit 200
queue-list 1 queue 2 byte-count 600 limit 200
queue-list 1 queue 3 byte-count 500 limit 200

```

Example: Traffic Shaping with ForeSight

The following example illustrates a router configuration with traffic shaping enabled. DLCIs 100 and 101 on subinterfaces Serial 13.2 and Serial 13.3 inherit class parameters from the main interface. The traffic shaping for these two VCs will be adaptive to the ForeSight notification.

For Serial 0, the output rate for DLCI 103 will not be affected by the router ForeSight function.

```

interface Serial0
no ip address
encapsulation frame-relay
frame-relay lmi-type ansi
frame-relay traffic-shaping
!
interface Serial0.2 point-to-point
ip address 10.128.30.17 255.255.255.248
frame-relay interface-dlci 102
class fast_vcs
!
interface Serial0.3 point-to-point
ip address 10.128.30.5 255.255.255.248
ip ospf cost 200
frame-relay interface-dlci 103

```

```

class slow_vcs
!
interface serial 3
no ip address
encapsulation frame-relay
frame-relay traffic-shaping
frame-relay class fast_vcs
!
interface Serial3.2 multipoint
ip address 100.120.20.13 255.255.255.248
frame-relay map ip 100.120.20.6 16 ietf broadcast
!
interface Serial3.3 point-to-point
ip address 100.120.10.13 255.255.255.248
frame-relay interface-dlci 101
!
map-class frame-relay slow_vcs
frame-relay adaptive-shaping becn
frame-relay traffic-rate 4800 9600
!
map-class frame-relay fast_vcs
frame-relay adaptive-shaping foresight
frame-relay traffic-rate 16000 64000
frame-relay cir 56000
frame-relay bc 64000

```

Example: LMI Configuration

- [Example: ELMI and Frame Relay Traffic Shaping](#)
- [Example: Configuring the IP Address for ELMI Address Registration](#)
- [Example: Disabling ELMI Address Registration on an Interface](#)

Example: ELMI and Frame Relay Traffic Shaping

The following configuration shows a Frame Relay interface enabled with QoS autosense. The router receives messages from the Cisco switch, which is also configured with QoS autosense enabled. When ELMI is configured in conjunction with traffic shaping, the router will receive congestion information through BECN or router ForeSight congestion signalling and reduce its output rate to the value specified in the traffic shaping configuration.

```

interface serial0
no ip address
encapsulation frame-relay
frame-relay lmi-type ansi
frame-relay traffic-shaping
frame-relay QoS-autosense
!
interface serial0.1 point-to-point
no ip address
frame-relay interface-dlci 101

```

Example: Configuring the IP Address for ELMI Address Registration

The following example shows how to configure the IP address to be used for ELMI address registration. Automatic IP address selection is automatically disabled when the IP address is configured. ELMI is enabled on serial interface 0.

```

interface Serial 0
no ip address

```

```

encapsulation frame-relay
 frame-relay lmi-type ansi
 frame-relay qos-autosense
!
frame-relay address registration ip address 139.85.242.195
!

```

Example: Disabling ELMI Address Registration on an Interface

In the following example, ELMI address registration is disabled on serial interface 0. This interface will share an IP address of 0.0.0.0 and an ifIndex of 0. Automatic IP address selection is enabled by default when ELMI is enabled, so the management IP address of other interfaces on this router will be chosen automatically.

```

interface Serial 0
 no ip address
 encapsulation frame-relay
 frame-relay lmi-type ansi
 frame-relay qos-autosense
 no frame-relay address-reg-enable
!

```

Example: Backward Compatibility

The following configuration provides backward compatibility and interoperability with versions not compliant with RFC 1490. The **ietf** keyword is used to generate RFC 1490 traffic. This configuration is possible because of the flexibility provided by separately defining each map entry.

```

encapsulation frame-relay
frame-relay map ip 131.108.123.2 48 broadcast ietf
! interoperability is provided by IETF encapsulation
frame-relay map ip 131.108.123.3 49 broadcast ietf
frame-relay map ip 131.108.123.7 58 broadcast
! this line allows the router to connect with a
! device running an older version of software
frame-relay map decnet 21.7 49 broadcast

```

Example: Booting from a Network Server over Frame Relay

When booting from a TFTP server over Frame Relay, you cannot boot from a network server via a broadcast. You must boot from a specific TFTP host. Also, a **frame-relay map** command must exist for the host from which you will boot.

For example, if file “gs3-bfx” is to be booted from a host with IP address 131.108.126.2, the following commands would need to be in the configuration:

```

boot system gs3-bfx 131.108.126.2
!
interface Serial 0
 encapsulation frame-relay
 frame-relay map IP 131.108.126.2 100 broadcast

```

The **frame-relay map** command is used to map an IP address into a DLCI address. To boot over Frame Relay, you must explicitly give the address of the network server to boot from, and a **frame-relay map** entry must exist for that site. For example, if file “gs3-bfx.83-2.0” is to be booted from a host with IP address 131.108.126.111, the following commands must be in the configuration:

```

boot system gs3-bfx.83-2.0 131.108.13.111

```

```

!
interface Serial 1
 ip address 131.108.126.200 255.255.255.0
 encapsulation frame-relay
 frame-relay map ip 131.108.126.111 100 broadcast

```

In this case, 100 is the DLCI that can get to host 131.108.126.111.

The remote router must be configured with the following command:

```
frame-relay map ip 131.108.126.200 101 broadcast
```

This entry allows the remote router to return a boot image (from the network server) to the router booting over Frame Relay. Here, 101 is a DLCI of the router being booted.

Example: Frame Relay Switching

- [Example: PVC Switching Configuration](#)
- [Example: Pure Frame Relay DCE](#)
- [Example: Hybrid DTE/DCE PVC Switching](#)
- [Example: Switching over an IP Tunnel](#)
- [Example: Frame Relay Switching over ISDN B Channels](#)
- [Example: Traffic Shaping on Switched PVCs](#)
- [Example: Traffic Policing on a UNI DCE](#)
- [Example: Congestion Management on Switched PVCs](#)
- [Example: Congestion Management on the Traffic-Shaping Queue of a Switched PVC](#)
- [Example: FRF.12 Fragmentation on a Switched PVC Configuration](#)

Example: PVC Switching Configuration

You can configure your router as a dedicated, DCE-only Frame Relay switch. Switching is based on DLCIs. The incoming DLCI is examined, and the outgoing interface and DLCI are determined. Switching takes place when the incoming DLCI in the packet is replaced by the outgoing DLCI, and the packet is sent out the outgoing interface.

In [Figure 10](#), the router switches two PVCs between serial interfaces 1 and 2. Frames with DLCI 100 received on serial 1 will be transmitted with DLCI 200 on serial 2.

Figure 10 PVC Switching Configuration

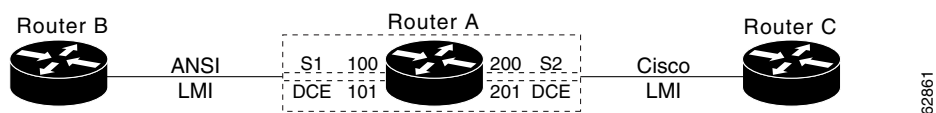

The following example shows one router with two interfaces configured as DCEs. The router switches frames from the incoming interface to the outgoing interface on the basis of the DLCI alone.

Configuration for Router A

```
frame-relay switching
```

```

interface Serial1
  no ip address
  encapsulation frame-relay
  keepalive 15
  frame-relay lmi-type ansi
  frame-relay intf-type dce
  frame-relay route 100 interface Serial2 200
  frame-relay route 101 interface Serial2 201
  clockrate 2000000
!
interface Serial2
  encapsulation frame-relay
  keepalive 15
  frame-relay intf-type dce
  frame-relay route 200 interface Serial1 100
  frame-relay route 201 interface Serial1 101
  clockrate 64000

```

Example: Pure Frame Relay DCE

Using the PVC switching feature, it is possible to build an entire Frame Relay network using routers. In [Figure 11](#), router A and router C act as Frame Relay switches implementing a two-node network. The standard Network-to-Network Interface (NNI) signalling protocol is used between router A and router C.

The following example shows a Frame Relay network with two routers functioning as switches and standard NNI signalling used between them.

Figure 11 Frame Relay DCE Configuration

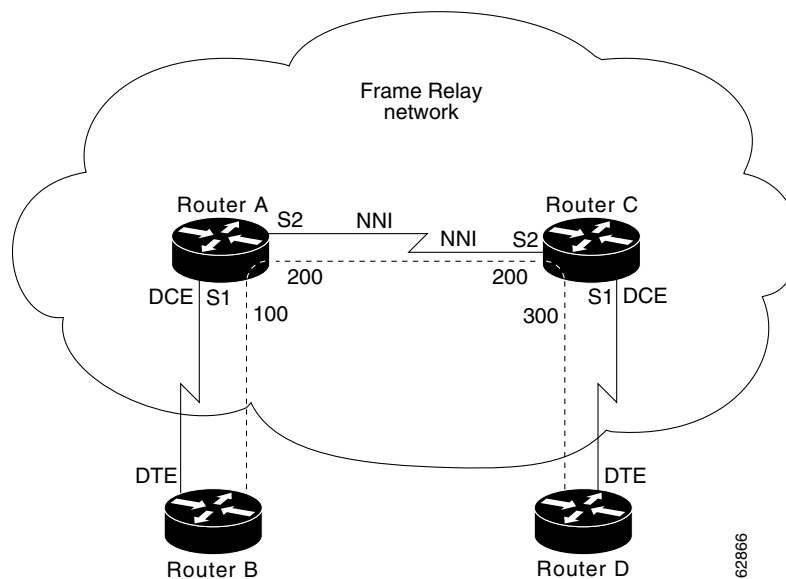

Configuration for Router A

```

frame-relay switching
!
interface serial 1
  no ip address

```

```

encapsulation frame-relay
frame-relay intf-type dce
frame-relay lmi-type ansi
frame-relay route 100 interface serial 2 200
!
interface serial 2
no ip address
encapsulation frame-relay
frame-relay intf-type nni
frame-relay lmi-type q933a
frame-relay route 200 interface serial 1 100
clockrate 2048000
!

```

Configuration for Router C

```

frame-relay switching
!
interface serial 1
no ip address
encapsulation frame-relay
frame-relay intf-type dce
frame-relay route 300 interface serial 2 200
!
interface serial 2
no ip address
encapsulation frame-relay
frame-relay intf-type nni
frame-relay lmi-type q933a
frame-relay route 200 interface serial 1 300
!

```

Example: Hybrid DTE/DCE PVC Switching

Routers can be configured as hybrid DTE/DCE Frame Relay switches, as shown in [Figure 12](#).

Figure 12 Hybrid DTE/DCE PVC Switching

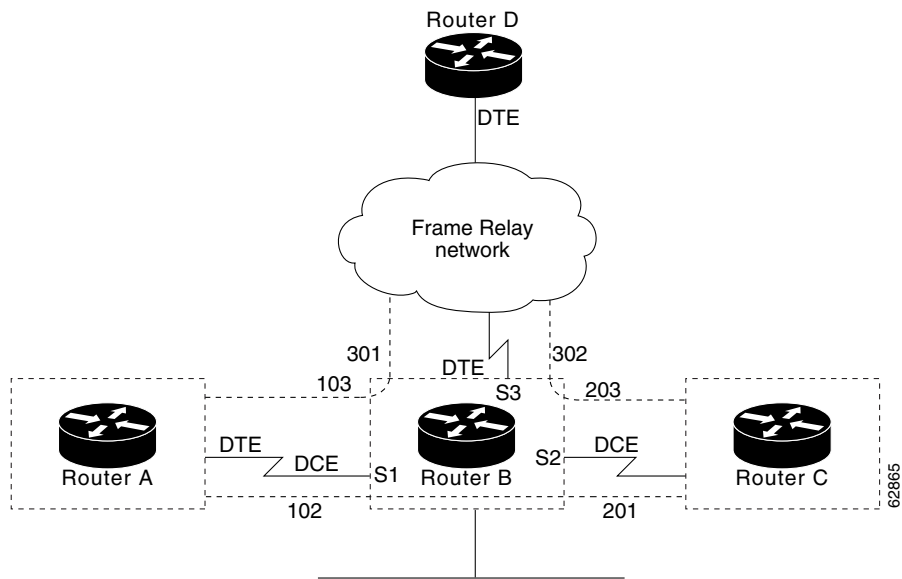

The following example shows one router configured with both DCE and DTE interfaces (router B acts as a hybrid DTE/DCE Frame Relay switch). It can switch frames between two DCE ports and between a DCE port and a DTE port. Traffic from the Frame Relay network can also be terminated locally. In the example, three PVCs are defined as follows:

- Serial 1, DLCI 102, to serial 2, DLCI 201—DCE switching
- Serial 1, DLCI 103, to serial 3, DLCI 301—DCE/DTE switching
- Serial 2, DLCI 203, to serial 3, DLCI 302—DCE/DTE switching

DLCI 400 is also defined for locally terminated traffic.

Configuration for Router B

```

frame-relay switching
!
interface ethernet 0
 ip address 131.108.123.231 255.255.255.0
!
interface ethernet 1
 ip address 131.108.5.231 255.255.255.0
!
interface serial 0
 no ip address
 shutdown :Interfaces not in use may be shut down; shut down is not required.
!
interface serial 1
 no ip address
 encapsulation frame-relay
 frame-relay intf-type dce
 frame-relay route 102 interface serial 2 201
 frame-relay route 103 interface serial 3 301
!
interface serial 2
 no ip address
 encapsulation frame-relay
 frame-relay intf-type dce
 frame-relay route 201 interface serial 1 102
 frame-relay route 203 interface serial 3 302
!
interface serial 3
 ip address 131.108.111.231
 encapsulation frame-relay
 frame-relay lmi-type ansi
 frame-relay route 301 interface serial 1 103
 frame-relay route 302 interface serial 1 203
 frame-relay map ip 131.108.111.4 400 broadcast

```

Example: Switching over an IP Tunnel

You can achieve switching over an IP tunnel by creating a point-to-point tunnel across the internetwork over which PVC switching can take place, as shown in [Figure 13](#).



Note

Static routes cannot be configured over tunnel interfaces on the Cisco 800 series, 1600 series, and 1700 series platforms. Static routes can only be configured over tunnel interfaces on platforms that have the Enterprise feature set.

Figure 13 Frame Relay Switch over IP Tunnel

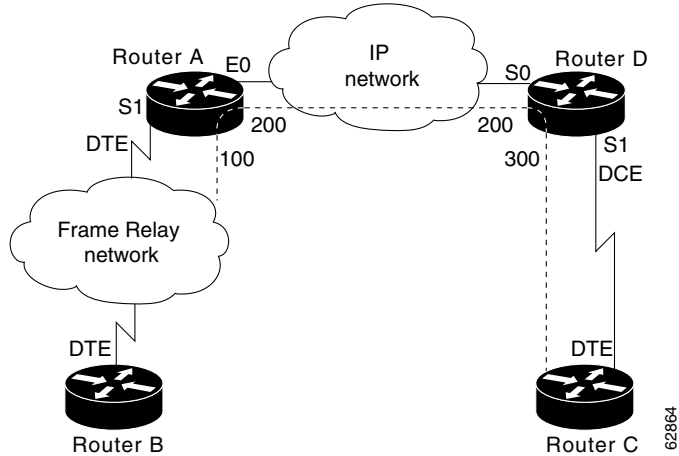

The following example shows two routers configured to switch Frame Relay PVCs over a point-to-point IP tunnel, which is the IP network configuration depicted in [Figure 13](#).

Configuration for Router A

```
frame-relay switching
!
interface ethernet0
 ip address 108.131.123.231 255.255.255.0
!
interface ethernet1
 ip address 131.108.5.231 255.255.255.0
!
interface serial0
 no ip address
 shutdown : Interfaces not in use may be shut down; shutdown is not required.
!
interface serial1
 ip address 131.108.222.231 255.255.255.0
 encapsulation frame-relay
 frame-relay map ip 131.108.222.4 400 broadcast
 frame-relay route 100 interface Tunnell 200
!
interface tunnell
 tunnel source Ethernet0
 tunnel destination 150.150.150.123
```

Configuration for Router D

```
frame-relay switching
!
interface ethernet0
 ip address 131.108.231.123 255.255.255.0
!
interface ethernet1
 ip address 131.108.6.123 255.255.255.0
!
interface serial0
 ip address 150.150.150.123 255.255.255.0
 encapsulation ppp
!
interface tunnell
 tunnel source Serial0
```

```

tunnel destination 108.131.123.231
!
interface serial1
 ip address 131.108.7.123 255.255.255.0
 encapsulation frame-relay
 frame-relay intf-type dce
 frame-relay route 300 interface Tunnel1 200

```

Example: Frame Relay Switching over ISDN B Channels

The following example illustrates Frame Relay switching over an ISDN dialer interface:

```

frame-relay switching
!
interface BRI0
 isdn switch-type basic-5ess
 dialer pool-member 1
 dialer pool-member 2
!
interface dialer1
 encapsulation frame-relay
 dialer pool 1
 dialer-group 1
 dialer caller 60038
 dialer string 60038
 frame-relay intf-type dce
!
interface dialer2
 encapsulation frame-relay
 dialer pool 2
 dialer-group 1
 dialer caller 60039
 dialer string 60039
 frame-relay intf-type dce
!
interface serial0
 encapsulation frame-relay
 frame-relay intf-type dce
!
connect one serial0 16 dialer1 100
connect two serial0 17 dialer2 100
dialer-list 1 protocol ip permit

```



Note

Note that when Frame Relay switching is performed by using a dialer profile, encapsulation of the underlying physical (BRI) interface must be configured as high-level data link control (HDLC).

Example: Traffic Shaping on Switched PVCs

In the example that follows, traffic on serial interface 0 is being shaped prior to entry to the Frame Relay network. PVC 100/16 is shaped according to the “shape256K” class. PVC 200/17 is shaped using the “shape64K” class inherited from the interface.

```

frame-relay switching
!
interface serial0
 encapsulation frame-relay
 frame-relay intf-type dce
 frame-relay traffic-shaping
 frame-relay class shape64K

```

```

        frame-relay interface-dlci 16 switched
            class shape256K
    !
interface serial1
    encapsulation frame-relay
    frame-relay intf-type dce
    !
connect one serial0 16 serial1 100
connect two serial0 17 serial1 200
    !
map-class frame-relay shape256K
    frame-relay traffic-rate 256000 512000
    !
map-class frame-relay shape64K
    frame-relay traffic-rate 64000 64000

```

Example: Traffic Policing on a UNI DCE

In the following example, incoming traffic is being policed on serial interface 1. The interface uses policing parameters configured in map class “police256K”. PVC 100/16 inherits policing parameters from the interface. PVC 200/17 uses policing parameters configured in “police64K”.

```

frame-relay switching
    !
interface serial0
    encapsulation frame-relay
    frame-relay intf-type dce
    !
interface serial1
    encapsulation frame-relay
    frame-relay policing
    frame-relay class police256K
    frame-relay intf-type dce
    frame-relay interface-dlci 200 switched
        class police64K
    !
connect one serial0 16 serial1 100
connect two serial0 17 serial1 200
    !
map-class frame-relay police256K
    frame-relay cir 256000
    frame-relay bc 256000
    frame-relay be 0
    !
map-class frame-relay police64K
    frame-relay cir 64000
    frame-relay bc 64000
    frame-relay be 64000

```

Example: Congestion Management on Switched PVCs

The following example illustrates the configuration of congestion management and DE discard levels for all switched PVCs on serial interface 1. Policing is configured on PVC 16.

```

frame-relay switching
    !
interface serial0
    encapsulation frame-relay
    frame-relay intf-type dce
    frame-relay policing
    frame-relay interface-dlci 16 switched

```

```

        class 256K
    !
interface serial1
    encapsulation frame-relay
    frame-relay intf-type dce
    frame-relay congestion-management
        threshold ecn be 0
        threshold ecn bc 20
        threshold de 40
    !
connect one serial1 100 serial0 16
    !
map-class frame-relay 256K
    frame-relay cir 256000
    frame-relay bc 256000
    frame-relay be 256000

```

Example: Congestion Management on the Traffic-Shaping Queue of a Switched PVC

The following example illustrates the configuration of congestion management in a class called “perpvc_congestion”. The class is associated with the traffic-shaping queue of DLCI 200 on serial interface 3.

```

map-class frame-relay perpvc_congestion
    frame-relay holdq 100
    frame-relay congestion threshold ecn 50

interface Serial3
    frame-relay traffic-shaping
    frame-relay interface-dlci 200 switched
    class perpvc_congestion

```

Example: FRF.12 Fragmentation on a Switched PVC Configuration

In the following example, FRF.12 fragmentation is configured in a map class called “data”. The “data” map class is assigned to switched pvc 20 on serial interface 3/3.

```

frame-relay switching
!
interface Serial3/2
    encapsulation frame-relay
    frame-relay intf-type dce
!
interface Serial3/3
    encapsulation frame-relay
    frame-relay traffic-shaping
    frame-relay interface-dlci 20 switched
    class data
    frame-relay intf-type dce
!
map-class frame-relay data
    frame-relay fragment 80 switched
    frame-relay cir 64000
    frame-relay bc 640
!
connect data Serial3/2 16 Serial3/3 20

```

Example: Frame Relay End-to-End Keepalive

- [Example: End-to-End Keepalive Bidirectional Mode with Default Configuration](#)
- [Example: End-to-End Keepalive Request Mode with Default Configuration](#)
- [Example: End-to-End Keepalive Request Mode with Modified Configuration](#)

Example: End-to-End Keepalive Bidirectional Mode with Default Configuration

In the following example, the devices at each end of a VC are configured so that a DLCI is assigned to a Frame Relay serial interface, a map class is associated with the interface, and Frame Relay end-to-end keepalive is configured in bidirectional mode using default values:

```
! router1
router1(config) interface serial 0/0.1 point-to-point
router1(config-if) ip address 10.1.1.1 255.255.255.0
router1(config-if) frame-relay interface-dlci 16
router1(config-if) frame-relay class vcgrp1
router1(config-if) exit
!
router1(config)# map-class frame-relay vcgrp1
router1(config-map-class)# frame-relay end-to-end keepalive mode bidirectional
! router2
router2(config) interface serial 1/1.1 point-to-point
router2(config-if) ip address 10.1.1.2 255.255.255.0
router2(config-if) frame-relay interface-dlci 16
router2(config-if) frame-relay class vceek
router1(config-if) exit
!
router2(config)# map-class frame-relay vceek
router2(config-map-class)# frame-relay end-to-end keepalive mode bidirectional
```

Example: End-to-End Keepalive Request Mode with Default Configuration

In the following example, the devices at each end of a VC are configured so that a DLCI is assigned to a Frame Relay serial interface and a map class is associated with the interface. One device is configured in request mode while the other end of the VC is configured in reply mode.

```
! router1
router1(config) interface serial 0/0.1 point-to-point
router1(config-if) ip address 10.1.1.1 255.255.255.0
router1(config-if) frame-relay interface-dlci 16
router1(config-if) frame-relay class eek
router1(config-if) exit
!
router1(config)# map-class frame-relay eek
router1(config-map-class)# frame-relay end-to-end keepalive mode request

! router2
router2(config) interface serial 1/1.1 point-to-point
router2(config-if) ip address 10.1.1.2 255.255.255.0
router2(config-if) frame-relay interface-dlci 16
router2(config-if) frame-relay class group_3
router1(config-if) exit
!
router2(config)# map-class frame-relay group_3
router2(config-map-class)# frame-relay end-to-end keepalive mode reply
```

Example: End-to-End Keepalive Request Mode with Modified Configuration

In the following example, the devices at each end of a VC are configured so that a DLCI is assigned to a Frame Relay serial interface and a map class is associated with the interface. One device is configured in request mode while the other end of the VC is configured in reply mode. The event window, error threshold, and success events values are changed so that the interface will change state less frequently:

```
! router1
router1(config) interface serial 0/0.1 point-to-point
router1(config-if) ip address 10.1.1.1 255.255.255.0
router1(config-if) frame-relay interface-dlci 16
router1(config-if) frame-relay class eek
router1(config-if) exit
!
router1(config)# map-class frame-relay eek
router1(config-map-class)# frame-relay end-to-end keepalive mode request
router1(config-map-class)# frame-relay end-to-end keepalive event-window send 5
router1(config-map-class)# frame-relay end-to-end keepalive error-threshold send 3
router1(config-map-class)# frame-relay end-to-end keepalive success-events send 3

! router2
router2(config) interface serial 1/1.1 point-to-point
router2(config-if) ip address 10.1.1.2 255.255.255.0
router2(config-if) frame-relay interface-dlci 16
router2(config-if) frame-relay class group_3
router1(config-if) exit
!
router2(config)# map-class frame-relay group_3
router2(config-map-class)# frame-relay end-to-end keepalive mode reply
```

Example: PPP over Frame Relay

- [Example: PPP over Frame Relay DTE](#)
- [Example: PPP over Frame Relay DCE](#)

Example: PPP over Frame Relay DTE

The following example configures a router as a DTE device for PPP over Frame Relay. Subinterface 2.1 contains the necessary DLCI and virtual template information. Interface Virtual-Template 1 contains the PPP information that is applied to the PPP session associated with DLCI 32 on serial subinterface 2.1.

```
interface serial 2
no ip address
encapsulation frame-relay
frame-relay lmi-type ansi
!
interface serial 2.1 point-to-point
frame-relay interface-dlci 32 ppp virtual-template1
!
interface Virtual-Template1
ip unnumbered ethernet 0
ppp authentication chap pap
```



Note

By default, the encapsulation type for a virtual template interface is PPP encapsulation; therefore, **encapsulation ppp** will not appear when you view the configuration of the router.

Example: PPP over Frame Relay DCE

The following example configures a router to act as a DCE device. Typically, a router is configured as a DCE if it is connecting directly to another router or if connected to a 90i D4 channel unit, which is connected to a telco channel bank. The three commands required for this type of configuration are the **frame-relay switching**, **frame-relay intf-type dce**, and **frame-relay route** commands:

```
frame-relay switching
!
interface Serial2/0:0
no ip address
encapsulation frame-relay IETF
frame-relay lmi-type ansi
frame-relay intf-type dce
frame-relay route 31 interface Serial1/2 100
frame-relay interface-dlci 32 ppp Virtual-Template1
!
interface Serial2/0:0.2 point-to-point
no ip address
frame-relay interface-dlci 40 ppp Virtual-Template2
!
interface Virtual-Template1
ip unnumbered Ethernet0/0
peer default ip address pool default
ppp authentication chap pap
!
interface Virtual-Template2
ip address 100.1.1.2 255.255.255.0
ppp authentication chap pap
```



Note

By default, the encapsulation type for a virtual template interface is PPP encapsulation; therefore, **encapsulation ppp** will not appear when you view the configuration of the router.

Example: Frame Relay Fragmentation Configuration

- [Example: FRF.12 Fragmentation](#)
- [Example: Frame Relay Fragmentation with Hardware Compression](#)

Example: FRF.12 Fragmentation

The following example shows the configuration of pure end-to-end FRF.12 fragmentation and weighted fair queueing in the map class called “frag”. The fragment payload size is set to 40 bytes. The “frag” map class is associated with DLCI 100 on serial interface 1.

```
router(config)# interface serial 1
router(config-if)# frame-relay traffic-shaping
router(config-if)# frame-relay interface-dlci 100
router(config-fr-dlci)# class frag
router(config-fr-dlci)# exit

router(config)# map-class frame-relay frag
router(config-map-class)# frame-relay cir 128000
router(config-map-class)# frame-relay bc 1280
router(config-map-class)# frame-relay fragment 40
router(config-map-class)# frame-relay fair-queue
```

Example: Frame Relay Fragmentation with Hardware Compression

In the following example, FRF.12 fragmentation and FRF.9 hardware compression are configured on multipoint interface 3/1 and point-to-point interface 3/1.1:

```
interface serial3/1
 ip address 10.1.0.1 255.255.255.0
 encapsulation frame-relay
 frame-relay traffic-shaping
 frame-relay class frag
 frame-relay map ip 10.1.0.2 110 broadcast ietf payload-compression frf9 stac
!
interface serial3/1.1 point-to-point
 ip address 10.2.0.1 255.255.255.0
 frame-relay interface-dlci 120 ietf
 frame-relay payload-compression frf9 stac
!
map-class frame-relay frag
 frame-relay cir 64000
 frame-relay bc 640
 frame-relay fragment 100
```

Example: Payload Compression Configuration

- [Example: FRF.9 Compression for Subinterfaces Using the frame-relay map Command](#)
- [Example: FRF.9 Compression for Subinterfaces](#)
- [Example: Data-Stream Hardware Compression with TCP/IP Header Compression on a Point-to-Point Subinterface](#)
- [Example: Data-Stream Hardware Compression with TCP/IP Header Compression on a Multipoint Subinterface](#)
- [Example: Data-Stream Hardware Compression with RTP Header Compression and Frame Relay Fragmentation](#)



Note

Shut down the interface or subinterface prior to adding or changing compression techniques. Although shutdown is not required, shutting down the interface ensures that it is reset for the new data structures.

Example: FRF.9 Compression for Subinterfaces Using the frame-relay map Command

The following example shows a subinterface being configured for FRF.9 compression using the **frame-relay map** command:

```
interface serial2/0/1
 ip address 172.16.1.4 255.255.255.0
 no ip route-cache
 encapsulation frame-relay IETF
 no keepalive
 frame-relay map ip 172.16.1.1 105 IETF payload-compression FRF9 stac
```

Example: FRF.9 Compression for Subinterfaces

The following example shows a subinterface being configured for FRF.9 compression:

```
interface serial2/0/0
```

```

no ip address
no ip route-cache
encapsulation frame-relay
ip route-cache distributed
no keepalive
!
interface serial2/0/0.500 point-to-point
ip address 172.16.1.4 255.255.255.0
no cdp enable
frame-relay interface-dlci 500 IETF
frame-relay payload-compression FRF9 stac

```

Example: Data-Stream Hardware Compression with TCP/IP Header Compression on a Point-to-Point Subinterface

The following example shows the configuration of data-stream hardware compression and TCP header compression on point-to-point interface 1/0.1:

```

interface serial1/0
  encapsulation frame-relay
  frame-relay traffic-shaping
!
interface serial1/0.1 point-to-point
ip address 10.0.0.1 255.0.0.0
frame-relay interface-dlci 100
frame-relay payload-compression data-stream stac
frame-relay ip tcp header-compression

```

Example: Data-Stream Hardware Compression with TCP/IP Header Compression on a Multipoint Subinterface

The following example shows the configuration of data-stream hardware compression and TCP header compression on multipoint interface 3/1:

```

interface serial3/1
ip address 10.1.0.1 255.255.255.0
encapsulation frame-relay
frame-relay traffic-shaping
frame-relay map ip 10.1.0.2 110 broadcast cisco payload-compression data-stream stac
frame-relay ip tcp header-compression

```

Example: Data-Stream Hardware Compression with RTP Header Compression and Frame Relay Fragmentation

The following example shows the configuration of data-stream hardware compression, RTP header compression, and FRF.12 fragmentation on point-to-point interface 1/0.1:

```

interface serial1/0
  encapsulation frame-relay
  frame-relay traffic-shaping
!
interface serial1/0.1 point-to-point
ip address 10.0.0.1 255.0.0.0
frame-relay interface-dlci 100
frame-relay class frag
frame-relay payload-compression data-stream stac
frame-relay ip rtp header-compression
!
map-class frame-relay frag

```

```
frame-relay cir 64000
frame-relay bc 640
frame-relay be 0
frame-relay fragment 100
frame-relay ip rtp priority 16000 16000 20
```

Example: TCP IP Header Compression

- [Example: IP Map with Inherited TCP IP Header Compression](#)
- [Example: Using an IP Map to Override TCP IP Header Compression](#)
- [Example: Disabling Inherited TCP IP Header Compression](#)
- [Example: Disabling Explicit TCP IP Header Compression](#)

Example: IP Map with Inherited TCP IP Header Compression



Note

Shut down the interface or subinterface prior to adding or changing compression techniques. Although shutdown is not required, shutting down the interface ensures that it is reset for the new data structures.

The following example shows an interface configured for TCP/IP header compression and an IP map that inherits the compression characteristics. Note that the Frame Relay IP map is not explicitly configured for header compression.

```
interface serial 1
 encapsulation frame-relay
 ip address 131.108.177.178 255.255.255.0
 frame-relay map ip 131.108.177.177 177 broadcast
 frame-relay ip tcp header-compression passive
```

Use of the **show frame-relay map** command will display the resulting compression and encapsulation characteristics; the IP map has inherited passive TCP/IP header compression:

```
Router> show frame-relay map
```

```
Serial 1 (administratively down): ip 131.108.177.177
 dlci 177 (0xB1,0x2C10), static,
 broadcast,
 CISCO
 TCP/IP Header Compression (inherited), passive (inherited)
```

This example also applies to dynamic mappings achieved with the use of Inverse ARP on point-to-point subinterfaces where no Frame Relay maps are configured.

Example: Using an IP Map to Override TCP IP Header Compression

The following example shows the use of a Frame Relay IP map to override the compression set on the interface:

```
interface serial 1
 encapsulation frame-relay
 ip address 131.108.177.178 255.255.255.0
 frame-relay map ip 131.108.177.177 177 broadcast nocompress
 frame-relay ip tcp header-compression passive
```

Use of the **show frame-relay map** command will display the resulting compression and encapsulation characteristics; the IP map has not inherited TCP header compression:

```
Router> show frame-relay map

Serial 1 (administratively down): ip 131.108.177.177
        dlci 177 (0xB1,0x2C10), static,
        broadcast,
        CISCO
```

Example: Disabling Inherited TCP IP Header Compression

In this example, the following is the initial configuration:

```
interface serial 1
 encapsulation frame-relay
 ip address 131.108.177.179 255.255.255.0
 frame-relay ip tcp header-compression passive
 frame-relay map ip 131.108.177.177 177 broadcast
 frame-relay map ip 131.108.177.178 178 broadcast tcp header-compression
```

Enter the following commands to enable inherited TCP/IP header compression:

```
serial interface 1
 no frame-relay ip tcp header-compression
```

Use of the **show frame-relay map** command will display the resulting compression and encapsulation characteristics:

```
Router> show frame-relay map

Serial 1 (administratively down): ip 131.108.177.177 177
        dlci 177(0xB1, 0x2C10), static,
        broadcast
        CISCO

Serial 1 (administratively down): ip 131.108.177.178 178
        dlci 178(0xB2,0x2C20), static
        broadcast
        CISCO
        TCP/IP Header Compression (enabled)
```

As a result, header compression is disabled for the first map (with DLCI 177), which inherited its header compression characteristics from the interface. However, header compression is not disabled for the second map (DLCI 178), which is explicitly configured for header compression.

Example: Disabling Explicit TCP IP Header Compression

In this example, the initial configuration is the same as in the preceding example, but you must enter the following set of commands to enable explicit TCP/IP header compression:

```
serial interface 1
 no frame-relay ip tcp header-compression
 frame-relay map ip 131.108.177.178 178 nocompress
```

Use of the **show frame-relay map** command will display the resulting compression and encapsulation characteristics:

```
Router> show frame-relay map

Serial 1 (administratively down): ip 131.108.177.177 177
        dlci 177(0xB1,0x2C10), static,
        broadcast
```

```
CISCO
Serial 1 (administratively down): ip 131.108.177.178 178
      dlc1 178(0xB2,0x2C20), static
      broadcast
CISCO
```

The result of the commands is to disable header compression for the first map (with DLCI 177), which inherited its header compression characteristics from the interface, and also explicitly to disable header compression for the second map (with DLCI 178), which was explicitly configured for header compression.

Additional References

Related Documents

Related Topic	Document Title
Cisco IOS Wide-Area Networking configuration tasks	<i>Cisco IOS XE Wide-Area Networking Configuration Guide</i>
Wide-Area networking commands	<i>Cisco IOS Wide-Area Networking Command Reference</i>
Sending DDR traffic over Frame Relay	<ul style="list-style-type: none"> • <i>Configuring Legacy DDR Spokes</i> • <i>Configuring Legacy DDR Hubs</i>
Installing software on a new router or access server by downloading from a central server over an interface that supports Frame Relay	<i>Loading and Maintaining System Images</i>
Using AutoInstall over Frame Relay	<i>Overview - Basic Configuration of a Cisco Networking Device</i>
Configuring transparent bridging between devices over a Frame Relay network	<i>Configuring Transparent Bridging</i>
Configuring source-route bridging between SNA devices over a Frame Relay network	<i>Configuring Source-Route Bridging</i>
Configuring serial tunnel (STUN) and block serial tunnel encapsulation between devices over a Frame Relay network	<i>Configuring Serial Tunnel and Block Serial Tunnel</i>
Configuring access between SNA devices over a Frame Relay network	<i>Configuring SNA Frame Relay Access Support</i>
Configuring Voice over Frame Relay Using FRF.11 and FRF.12	<i>Configuring Voice over Frame Relay</i>
Configuring low latency queueing, PVC interface priority queueing, and link fragmentation and interleaving using multilink PPP for Frame Relay	<i>Cisco IOS Quality of Service Solutions Configuration Guide</i>

Standards

Standard	Title
None	—

MIBs

MIB	MIBs Link
None	To locate and download MIBs for selected platforms, Cisco IOS XE software releases, and feature sets, use Cisco MIB Locator found at the following URL: http://www.cisco.com/go/mibs

RFCs

RFC	Title
None	—

Technical Assistance

Description	Link
<p>The Cisco Support website provides extensive online resources, including documentation and tools for troubleshooting and resolving technical issues with Cisco products and technologies.</p> <p>To receive security and technical information about your products, you can subscribe to various services, such as the Product Alert Tool (accessed from Field Notices), the Cisco Technical Services Newsletter, and Really Simple Syndication (RSS) Feeds.</p> <p>Access to most tools on the Cisco Support website requires a Cisco.com user ID and password.</p>	<p>http://www.cisco.com/techsupport</p>

Cisco and the Cisco logo are trademarks or registered trademarks of Cisco and/or its affiliates in the U.S. and other countries. To view a list of Cisco trademarks, go to this URL: www.cisco.com/go/trademarks. Third-party trademarks mentioned are the property of their respective owners. The use of the word partner does not imply a partnership relationship between Cisco and any other company. (1110R)

Any Internet Protocol (IP) addresses used in this document are not intended to be actual addresses. Any examples, command display output, and figures included in the document are shown for illustrative purposes only. Any use of actual IP addresses in illustrative content is unintentional and coincidental.

© 2001–2011 Cisco Systems, Inc. All rights reserved.

