



Configuring Frame Relay-ATM Interworking

The Frame Relay-ATM Interworking features enable Frame Relay and ATM networks to exchange data, despite differing network protocols. There are two types of Frame Relay-ATM Interworking:

- [FRF.5 Frame Relay-ATM Network Interworking](#)
- [FRF.8 Frame Relay-ATM Service Interworking](#)

For further general information about Frame Relay-ATM Interworking, see the “[Wide-Area Networking Overview](#)” chapter at the beginning of this book.

For a description of the commands used to configure Frame Relay-ATM Interworking, refer to the chapter “Frame Relay-ATM Interworking Commands” in the *Cisco IOS Wide-Area Networking Command Reference*. To locate documentation of other commands that appear in this chapter, use the command reference master index or search online.

To identify the hardware platform or software image information associated with a feature, use the Feature Navigator on Cisco.com to search for information about the feature or refer to the software release notes for a specific release. For more information, see the section “[Identifying Supported Platforms](#)” in the chapter “Using Cisco IOS Software.”

For Cisco IOS Release 12.2, Frame Relay-ATM Interworking is supported on the following platforms and interface types:

- Cisco MC3810: T1/E1 ATM interface
- Cisco 3600 series routers: OC-3 and inverse multiplexing over ATM (IMA) network modules
- Cisco 2600 series routers: OC-3 and IMA network modules
- Cisco 7200 series routers: all Cisco 7200 series ATM interface types

Prerequisites

If the end station is a Cisco router that is connected to an FRF.8 router or switch in translation mode, you must configure the end station with IETF encapsulation (not Cisco encapsulation, which is the default). To do so, you use the **encapsulation frame relay ietf** command.

IETF encapsulation on the end station is not required for FRF.8 in transparent mode (or for FRF.5 in translation mode or transparent mode). The FRF.5 or FRF.8 router or switch itself does not need IETF encapsulation in translation mode or transparent mode.



Americas Headquarters:
Cisco Systems, Inc., 170 West Tasman Drive, San Jose, CA 95134-1706 USA

© 2007 Cisco Systems, Inc. All rights reserved.

FRF.5 Frame Relay-ATM Network Interworking

FRF.5 provides network interworking functionality that allows Frame Relay end users to communicate over an intermediate ATM network that supports FRF.5. Multiprotocol encapsulation and other higher-layer procedures are transported transparently, just as they would be over leased lines. Figure 35 illustrates this concept.

Figure 35 Frame Relay-to-ATM Network Interworking (FRF.5)

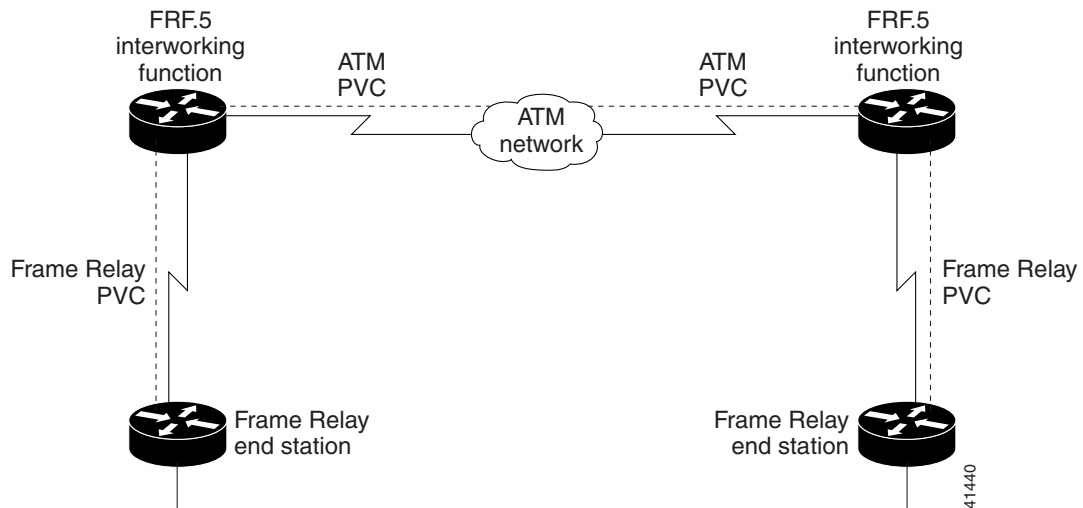

FRF.5 describes network interworking requirements between Frame Relay Bearer Services and Broadband ISDN (BISDN) permanent virtual circuit (PVC) services.

The FRF.5 standard is defined by the Frame Relay Forum Document Number FRF.5: *Frame Relay/ATM PVC Network Interworking Implementation Agreement*. For more information about which sections of this implementation agreement are supported by Cisco IOS software, see the appendix “[Frame Relay-ATM Interworking Supported Standards](#)” in this book.



Note

On Cisco 7200 series routers, Frame Relay-ATM interworking does not support congestion management bit mapping.

Configuring FRF.5

To configure FRF.5 Frame Relay-ATM Network Interworking, perform the tasks in the following sections. Each task is identified as either required or optional.

- [Configuring an FRF.5 One-to-One Network Interworking Connection](#) (Required)
- [Configuring an FRF.5 Many-to-One Network Interworking Connection](#) (Required)
- [Verifying FRF.5 Configuration](#) (Optional)

For FRF.5 configuration Examples, see the section “[FRF.5 Configuration Examples](#)” later in this chapter.

Configuring an FRF.5 One-to-One Network Interworking Connection

To configure FRF.5 encapsulation for a one-to-one connection between two Frame Relay end users over an intermediate ATM network, use the following commands beginning in global configuration mode:

	Command	Purpose
Step 1	Router(config)# interface <i>serial number</i>	Configures the Frame Relay interface and enters interface configuration mode.
Step 2	Router(config-if)# frame-relay interface-dlci <i>dlci</i> switched	Configures a switched Frame Relay DLCI.
Step 3	Router(config)# interface atm <i>number</i>	Configures the ATM interface and enters interface configuration mode.
Step 4	Router(config-if)# pvc [<i>PVC-name</i>] <i>vpi/vci</i>	Creates the ATM PVC and virtual path identifier/virtual channel identifier (VPI/VCI). The VCI is a 16-bit field in the header of the ATM cell.
Step 5	Router(config-if-atm-vc)# encapsulation aal5mux frame-relay	Configures the ATM adaption layer (AAL) and encapsulation type for the ATM PVC.
Step 6	Router(config)# connect <i>connection-name</i> <i>FR-interface FR-DLCI ATM-interface ATM-PVC</i> network-interworking	Creates a connection to connect the Frame Relay DLCI to the ATM PVC and configures FRF.5 encapsulation.
Step 7	Router(config-frf5)# clp-bit {0 1 map-de } or Router(config-frf5)# de-bit map-clp	(On Cisco MC3810, 2600 series, and 3600 series routers only) Sets the ATM cell loss priority (CLP) field in the ATM cell header. (On Cisco MC3810, 2600 series, and 3600 series routers only) Sets discard eligible (DE) bit mapping from ATM to Frame Relay.
Step 8	Router(config-frf5)# end	Ends configuration mode and enters EXEC mode. Use the exit command to exit a submode and reenter global configuration command mode.

To disconnect the FRF.5 interworking connection, use the **shutdown** connect subcommand.

Configuring an FRF.5 Many-to-One Network Interworking Connection

To configure FRF.5 encapsulation for a many-to-one connection between two Frame Relay end users over an intermediate ATM network, use the following commands beginning in global configuration command mode:

	Command	Purpose
Step 1	Router(config)# interface <i>serial number</i>	Configures the Frame Relay interface and enters interface configuration mode.
Step 2	Router(config-if)# frame-relay interface-dlci <i>dlci</i> switched	Configures a switched Frame Relay DLCI.
Step 3	Router(config)# vc-group <i>group-name</i>	Assigns multiple Frame Relay DLCIs to a VC group.

	Command	Purpose
Step 4	Router(config-vc-group)# <i>FR-interface-name</i> <i>FR-DLCI [FR-SSCS-DLCI]</i>	Specifies the Frame Relay DLCIs in the VC group and maps them to the Frame Relay-SSCS DLCIs. If the optional Frame Relay-SSCS DLCI value is not specified, its value will default to 1022.
Step 5	Router(config)# interface atm <i>number</i>	Configures the ATM interface and enters interface configuration mode.
Step 6	Router(config-if)# pvc [<i>PVC-name</i>] <i>vpi/vci</i>	Creates the ATM PVC and VPI/VCI. The VCI is a 16-bit field in the header of the ATM cell.
Step 7	Router(config-if-atm-vc)# encapsulation aal5mux frame-relay	Configures the AAL and encapsulation type for the ATM PVC.
Step 8	Router(config)# connect connection-name vc-group group-name ATM-interface ATM-vpi/vci	Creates a connection to connect the VC group to the ATM PVC.
Step 9	Router(config-frf5)# clp-bit {0 1 map-de} or Router(config-frf5)# de-bit map-clp	(On Cisco MC3810, 2600 series, and 3600 series routers only) Sets the ATM CLP field in the ATM cell header. (On Cisco MC3810, 2600 series, and 3600 series routers only) Sets DE bit mapping from ATM to Frame Relay.
Step 10	Router(config-frf5)# end	Ends configuration mode and enters EXEC mode. Use the exit command to exit a submode and reenter global configuration command mode.

To disconnect the FRF.5 interworking connection, use the **shutdown** connect subcommand.

Verifying FRF.5 Configuration

To verify correct configuration of the Frame Relay-to-ATM Network Interworking (FRF.5) feature, perform the following tasks:

- Step 1** Enter the **show connect id** EXEC command to view information, including interworking parameters set, for the specified connection identifier:

```
C3640# show connect id 5

FR/ATM Network Interworking Connection: network-1
Status      - UP
Segment 1   - VC-Group network-1
Segment 2   - ATM3/0 VPI 1 VCI 34
Interworking Parameters -
de-bit map-clp
clp-bit map-de
```

- Step 2** Enter the **show connect port** EXEC command to view information about the connection on a specific interface:

```
C3640# show connect port atm3/0

ID   Name                Segment 1                Segment 2                State
=====
5    network-1            VC-Group network-1      ATM3/0 1/34              UP
```

- Step 3** Enter the **show frame-relay pvc** EXEC command to view statistics about Frame Relay interfaces:

```

C3640# show frame-relay pvc

PVC Statistics for interface Serial1/0 (Frame Relay DCE)

          Active      Inactive      Deleted      Static
Local          0          0          0          0
Switched       1          0          0          0
Unused         0          0          0          0

DLCI = 18, DLCI USAGE = FRF.5, PVC STATUS = ACTIVE, INTERFACE =
Serial1/0

input pkts 22          output pkts 21          in bytes 2140
out bytes 2110        dropped pkts 0          in FECN pkts 0
in BECN pkts 0       out FECN pkts 0        out BECN pkts 0
in DE pkts 0         out DE pkts 0          out bcast pkts 0
out bcast pkts 0     out bcast bytes 0      Num Pkts
Switched 22
pvc create time 02:02:49, last time pvc status changed 02:02:42

```

Step 4 Enter the `show atm pvc EXEC` command to view ATM PVCs and statistics:

```

C3640# show atm pvc

Interface   VCD/      Peak   Avg/Min   Burst
Name       VPI   VCI   Type   Encaps   SC   Kbps   Kbps   Cells   Sts
-----
3/0        10    1    32   PVC   FR-ATM   UBR   155000

```

FRF.8 Frame Relay-ATM Service Interworking

FRF.8 provides service interworking functionality that allows a Frame Relay end user to communicate with an ATM end user. Traffic is translated by a protocol converter that provides communication between dissimilar Frame Relay and ATM equipment. [Figure 36](#) illustrates this concept.

Figure 36 Frame Relay-to-ATM Service Interworking (FRF.8)

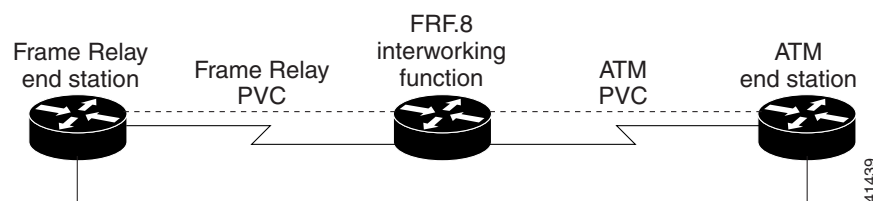

FRF.8 describes a one-to-one mapping between a Frame Relay and an ATM PVC.

The FRF.8 standard is defined by the Frame Relay Forum Document Number FRF.8: *Frame Relay/ATM PVC Network Service Interworking Implementation Agreement*. For more information about which sections of this implementation agreement are supported, see the appendix “[Frame Relay-ATM Interworking Supported Standards](#)” in this book.



Note

On Cisco 7200 series routers, Frame Relay-ATM interworking does not support congestion management bit mapping.

Configuring FRF.8

See the following sections for configuration tasks for the FRF.8 Frame Relay-to-ATM Service Interworking feature. Each task in the list is identified as either optional or required.

- [Configuring an FRF.8 Service Interworking Connection](#) (Required)
- [Verifying FRF.8 Configuration](#) (Optional)

Configuring an FRF.8 Service Interworking Connection

To configure FRF.8 one-to-one protocol mapping between a Frame Relay end user and an ATM end user, use the following commands beginning in global configuration command mode:

	Command	Purpose
Step 1	Router(config)# interface <i>serial number</i>	Configures the Frame Relay interface and enters interface configuration mode.
Step 2	Router(config-if)# frame-relay interface-dlci <i>dlci switched</i>	Configures a switched Frame Relay DLCI.
Step 3	Router(config)# interface atm <i>number</i>	Configures the ATM interface and enters interface configuration mode.
Step 4	Router(config-if)# pvc [<i>PVC-name</i>] <i>vpi/vci</i>	Creates the ATM PVC and virtual path identifier/virtual channel identifier (VPI/VCI). The VCI is a 16-bit field in the header of the ATM cell.
Step 5	Router(config-if)# encapsulation aal5mux fr-atm-srv	Configures the ATM adaption layer (AAL) and encapsulation type for the ATM PVC.
Step 6	Router(config)# connect <i>connection-name</i> <i>FR-interface FR-DLCI ATM-interface ATM-vpi/vci</i> service-interworking	Creates a connection to connect the Frame Relay DLCI to the ATM PVC and configures FRF.8 encapsulation.
Step 7	Router(config-frf8)# clp-bit {0 1 map-de } or Router(config-frf8)# de-bit {0 1 map-clp } or Router(config-frf8)# efci-bit {0 map-fecn }	(On Cisco MC3810, 2600 series, and 3600 series routers only) Sets the ATM cell loss priority (CLP) field in the ATM cell header. (On Cisco MC3810, 2600 series, and 3600 series routers only) Sets the Frame Relay discard eligible (DE) bit field in the Frame Relay cell header. (On Cisco MC3810, 2600 series, and 3600 series routers only) Sets the explicit forward congestion indication (EFCI) bit field in the ATM cell header.
Step 8	Router(config-frf8)# service translation	Enables upper layer user protocol encapsulation for Frame Relay-to-ATM service interworking.
Step 9	Router(config-frf8)# end	Ends configuration mode and enters EXEC mode. Use the exit command to exit a submode and reenter global configuration command mode.

To disconnect the FRF.8 interworking connection, use the **shutdown** connect subcommand.

Verifying FRF.8 Configuration

To verify correct configuration of the Frame Relay-to-ATM Service Interworking (FRF.8) feature, perform the following tasks:

- Step 1** Enter the **show connect id** EXEC command to view information, including interworking parameters set, about the specified connection identifier:

```
C3640# show connect id 10

FR/ATM Service Interworking Connection: service-1
  Status      - UP
  Segment 1 - Serial1/0 DLCI 16
  Segment 2 - ATM3/0 VPI 1 VCI 32
Interworking Parameters -
  service translation
  efcf-bit 0
  de-bit map-clp
  clp-bit map-de
```

- Step 2** Enter the **show connect port** EXEC command to view information about the connection on a specific interface:

```
C3640# show connect port atm3/0

ID   Name           Segment 1           Segment 2           State
-----
10   service-1       Serial1/0 16       ATM3/0 1/32         UP
```

- Step 3** Enter the **show frame-relay pvc** EXEC command to view statistics about Frame Relay interfaces:

```
C3640# show frame-relay pvc

PVC Statistics for interface Serial1/0 (Frame Relay DCE)

          Active      Inactive      Deleted      Static
Local            0            0            0            0
Switched         1            0            0            0
Unused           0            0            0            0

DLCI = 18, DLCI USAGE = FRF.5, PVC STATUS = ACTIVE, INTERFACE =
Serial1/0

input pkts 22          output pkts 21          in bytes 2140
out bytes 2110        dropped pkts 0          in FECN pkts 0
in BECN pkts 0       out FECN pkts 0        out BECN pkts 0
in DE pkts 0         out DE pkts 0          out bcast pkts 0      out bcast bytes 0      Num Pkts
Switched 22
pvc create time 02:02:49, last time pvc status changed 02:02:42
```

- Step 4** Enter the **show atm pvc** EXEC command to view ATM PVCs and statistics:

```
C3640# show atm pvc

Interface   VCD/   Peak  Avg/Min  Burst  Sts
Name       VPI   VCI   Type   Encaps  SC    Kbps  Kbps   Cells
3/0        10    1    32    PVC     FRATMSRV  UBR  155000
UP
```

Monitoring and Maintaining Frame Relay-to-ATM Interworking

To display the status of the virtual circuits and the Frame Relay-to-ATM interworking connections, use any of the following commands in EXEC mode

Command	Purpose
Router# show atm pvc [signalling interface <i>vcd</i>]	Displays all ATM PVCs, switched virtual circuits (SVCs), and traffic information. Use the signalling keyword to display ATM interface signalling information for all interfaces. Use the interface keyword to display all PVCs and SVCs on the interface or subinterface. Use the <i>vcd</i> argument to specify the ATM VCD number (1–1023) about which to display information.
Router# show connect [all <i>element</i> <i>ID</i> <i>name</i> <i>port</i>]	Displays connection statistics. Use the optional all keyword to display statistics about all connections. Use the optional <i>element</i> , <i>ID</i> , <i>name</i> , and <i>port</i> arguments to display particular connection details.
Router# show frame-relay pvc	Displays statistics about Frame Relay interfaces.
Router# show vc-group	Displays the names of all VC groups.

FRF.5 and FRF.8 Configuration Examples

The following sections provide examples to help you understand how to configure FRF.5 Frame Relay-ATM Network Interworking and FRF.8 Frame Relay-ATM Service Interworking:

- [FRF.5 Configuration Examples](#)
- [FRF.8 Configuration Example](#)

FRF.5 Configuration Examples

This section contains the following examples of FRF.5 Frame Relay-ATM Network Interworking:

- [FRF.5 One-to-One Connection Example](#)
- [FRF.5 Many-to-One Connection Example](#)

FRF.5 One-to-One Connection Example

The following example shows how to configure an FRF.5 one-to-one connection:

```
! Configure a switched Frame Relay DLCI
!
interface serial0
 frame-relay interface-dlci 100 switched
!
! Configure ATM PVC with FRF.5 encapsulation
!
interface atm3/0
 pvc 0/32
  encapsulation aal5mux frame-relay
```

```

!
! Create a connection to connect Frame Relay DLCI 100 to ATM PVC 0/32
!
connect serial0 100 atm3/0 0/32 network-interworking
  clp-bit 1
  de-bit map-clp

```

**Note**

Congestion management parameters are not available for Frame Relay-ATM Interworking on the Cisco 7200 series routers.

FRF.5 Many-to-One Connection Example

The following example shows how to configure an FRF.5 many-to-one connection:

```

! Configure a Frame Relay VC group
!
! The vc-group command assigns Frame Relay DLCI 16, 17, 18,
! and 19 to a VC group named 'friends'.
!
vc-group friends
  serial0 16 16
  serial0 17 17
  serial0 18 18
  serial0 19 19
!
! Configure an ATM PVC with FRF.5 encapsulation
!
interface atm3/0
  pvc 0/32
    encapsulation aal5mux frame-relay
!
! Create a connection which connects VC group 'friends' to ATM PVC 0/32
! and configure FR DE field mapping to match ATM CLP field
!
connect vc-group friends atm3/0 0/32
  de-bit map-clp

```

**Note**

Congestion management parameters are not available for Frame Relay-ATM Interworking on the Cisco 7200 series routers.

FRF.8 Configuration Example

This section contains the [FRF.8 Service Interworking Example](#).

FRF.8 Service Interworking Example

The following example shows how to configure an FRF.8 service interworking connection:

```

! Configure a switched Frame Relay DLCI
!
interface serial 0
  frame-relay interface-dlci 100 switched
!
! Configure an ATM PVC with FRF.8 encapsulation
!

```

```
interface atm1/0
  pvc 0/32
    encapsulation aal5mux fr-atm-srv
  !
  ! Create a connection that connects Frame Relay DLCI 100 to ATM PVC 1/32
  !
  connect service-1 Serial0 100 ATM3/0 0/32 service-interworking
    efci-bit map-fecn
```

**Note**

Congestion management parameters are not available for Frame Relay-ATM Interworking on the Cisco 7200 series routers.

CCVP, the Cisco logo, and Welcome to the Human Network are trademarks of Cisco Systems, Inc.; Changing the Way We Work, Live, Play, and Learn is a service mark of Cisco Systems, Inc.; and Access Registrar, Aironet, Catalyst, CCDA, CCDP, CCIE, CCIP, CCNA, CCNP, CCSP, Cisco, the Cisco Certified Internetwork Expert logo, Cisco IOS, Cisco Press, Cisco Systems, Cisco Systems Capital, the Cisco Systems logo, Cisco Unity, Enterprise/Solver, EtherChannel, EtherFast, EtherSwitch, Fast Step, Follow Me Browsing, FormShare, GigaDrive, HomeLink, Internet Quotient, IOS, iPhone, IP/TV, iQ Expertise, the iQ logo, iQ Net Readiness Scorecard, iQuick Study, LightStream, Linksys, MeetingPlace, MGX, Networkers, Networking Academy, Network Registrar, PIX, ProConnect, ScriptShare, SMARTnet, StackWise, The Fastest Way to Increase Your Internet Quotient, and TransPath are registered trademarks of Cisco Systems, Inc. and/or its affiliates in the United States and certain other countries.

All other trademarks mentioned in this document or Website are the property of their respective owners. The use of the word partner does not imply a partnership relationship between Cisco and any other company. (0711R)

Any Internet Protocol (IP) addresses used in this document are not intended to be actual addresses. Any examples, command display output, and figures included in the document are shown for illustrative purposes only. Any use of actual IP addresses in illustrative content is unintentional and coincidental.

© 2007 Cisco Systems, Inc. All rights reserved.