



## Configuring SIP ISDN Features

---

This chapter discusses the following SIP features that support ISDN:

- ISDN Calling Name Display
- Signal ISDN B-Channel ID to Enable Application Control of Voice Gateway Trunks
- SIP Carrier Identification Code (CIC)
- SIP: CLI for Caller ID When Privacy Exists
- SIP: ISDN Suspend/Resume Support
- SIP PSTN Transport Using the Cisco Generic Transparency Descriptor (GTD)

### Feature History for ISDN Calling Name Display

Release	Modification
12.3(4)T	This feature was introduced.

### Feature History for Signal ISDN B-Channel ID to Enable Application Control of Voice Gateway Trunks

Release	Modification
12.3(7)T	This feature was introduced.

### Feature History for SIP Carrier Identification Code

Release	Modification
12.2(11)T	This feature was introduced.

### Feature History for SIP: CLI for Caller ID When Privacy Exists Feature

Release	Modification
12.4(4)T	This feature was introduced.

### Feature History for SIP: ISDN Suspend/Resume Support

Release	Modification
12.2(15)T	This feature was introduced.



---

**Americas Headquarters:**  
Cisco Systems, Inc., 170 West Tasman Drive, San Jose, CA 95134-1706 USA

© 2007 Cisco Systems, Inc. All rights reserved.

### Feature History for SIP PSTN Transport Using the Cisco Generic Transparency Descriptor

Release	Modification
12.3(1)	This feature was introduced.

### Finding Support Information for Platforms and Cisco IOS Software Images

Use Cisco Feature Navigator to find information about platform support and Cisco IOS software image support. Access Cisco Feature Navigator at <http://www.cisco.com/go/fn>. You must have an account on Cisco.com. If you do not have an account or have forgotten your username or password, click **Cancel** at the login dialog box and follow the instructions that appear.

## Contents

- [Prerequisites for SIP ISDN Support, page 2](#)
- [Restrictions for SIP ISDN Support, page 3](#)
- [Information About SIP ISDN Support, page 4](#)
- [How to Configure SIP ISDN Support Features, page 15](#)
- [Configuration Examples for SIP ISDN Support Features, page 31](#)
- [Additional References, page 51](#)

## Prerequisites for SIP ISDN Support

### ISDN Calling Name Display Feature

- Configure Generic Transparency Descriptor (GTD) on your SIP network.



**Note** For information on SIP support for communicating ISDN information using GTD bodies, see the “[SIP PSTN Transport Using the Cisco Generic Transparency Descriptor](#)” section on [page 12](#).

- Enable the Remote-Party-ID header on your SIP network. In general, Remote-Party-ID is enabled by default and no configuration is necessary. The Remote-Party-ID header provides translation capabilities for ISDN screening and presentation indicators in call setup messages.



**Note** For information on the Remote-Party-ID header, see the “[SIP Extensions for Caller Identity and Privacy](#)” section on [page 13](#).

- Use this feature in a uni-directional deployment beginning with an originating gateway. For example, the flow must be from a gateway to a phone or gateway to an application server.

### Signal ISDN B-Channel ID to Enable Application Control of Voice Gateway Trunks Feature

- Configure the SIP protocol.

### SIP: CLI for Caller ID When Privacy Exists

- Establish a working IP network.

- Configure VoIP.
- Ensure that the gateway has voice functionality configured for SIP.



---

**Note** For information about configuring voice functionality, see the [Cisco IOS Voice Configuration Library](#).

---

#### SIP ISDN Suspend/Resume Support Feature

- Configure ISDN switch types on the gateway to support Suspend and Resume messages.

#### SIP PSTN Transport Using the Cisco Generic Transparency Descriptor Feature

- Configure your VoIP network, including the following components:
  - Cisco PGW 2200 signaling controller (SC) in Cisco MGC Software Release 9.2(2)



---

**Note** The Cisco PGW 2200 SC is formerly known as the Cisco Media Gateway Controller (MGC) and the Cisco SC 2200 signaling controller.

---

- Cisco Signaling Link Terminal (Cisco SLT), which performs Signaling System 7 (SS7) signal preprocessing for a Cisco PGW 2200 SC
- Cisco IOS gateways to allow sending and processing of SS7 ISUP messages in GTD format: Cisco IOS Release 12.3(1)
- Cisco SS7 Interconnect for Voice Gateways solution

## Restrictions for SIP ISDN Support

#### SIP Carrier Identification Code Feature

- SIP gateways receive the CIC parameter in SIP INVITE or 302 REDIRECT messages only.
- SIP gateways do not add or configure CIC parameters.
- The TNS IE in the ISDN SETUP message does not map to the CIC parameter in a SIP INVITE request. It is only the CIC parameter that maps to the TNS IE in the outgoing ISDN SETUP message.



---

**Note** The workaround created in Cisco IOS Release 12.3(2)XB is no longer supported with the release of this feature. The workaround handled the CIC parameter by including it in the called-party number. The To header in the SIP INVITE message that contained the called-party number was prefixed with 101xxx, where xxx was the CIC parameter. The number was then sent to the ISDN in the SETUP message. When the ISDN received the number, for example, 101032119193921234

the ISDN ignored the 101 and then routed the call to carrier 0321, as if 0321 was in the TNS IE of the outgoing SETUP message. The rest of the number, formatted as the called-party number, was forwarded to the carrier.

---

- Support for the CIC parameter is addressed by the expired IETF draft-yu-tel-url-02.txt. The SIP Carrier Identification Code feature does not encompass all areas that are addressed in the draft.

**SIP: ISDN Suspend/Resume Support Feature**

- SIP ISDN Suspend/Resume support is available only for ISDN PRI trunks connected at the gateway.

**SIP PSTN Transport Using the Cisco Generic Transparency Descriptor Feature**

- Redundant Link Manager (RLM) is a requirement for the SIP PSTN Transport Using the Cisco Generic Transparency Descriptor feature. As a result, only the following platforms that use RLM are supported: Cisco AS5300, Cisco AS5350, and Cisco AS5400.



---

**Note** For information on RLM, see [Redundant Link Manager \(RLM\)](#).

---

- SIP-T also transparently transmits ISUP messages across a SIP network, but the process is not supported in this feature.

## Information About SIP ISDN Support

To configure SIP ISDN support features, you should understand the following concepts:

- [ISDN Calling Name Display, page 4](#)
- [Signal ISDN B-Channel ID to Enable Application Control of Voice Gateway Trunks, page 6](#)
- [SIP Carrier Identification Code, page 7](#)
- [SIP: CLI for Caller ID When Privacy Exists, page 7](#)
- [SIP: ISDN Suspend/Resume Support, page 11](#)
- [SIP PSTN Transport Using the Cisco Generic Transparency Descriptor, page 12](#)

## ISDN Calling Name Display

With releases earlier than Cisco IOS Release 12.2(15)ZJ, when a call came in from the ISDN network to a SIP gateway, the calling name as presented in ISDN Q.931 messages (Setup and/or Facility) was not transported end-to-end over the VoIP cloud to a SIP endpoint (a SIP IP phone). With this feature, SIP signaling on Cisco IOS gateways has been enhanced to update the calling name and number information in SIP headers as per the recommended SIP standards. Also included is the complete translation of ISDN screening and presentation indicators, allowing SIP customers basic caller ID privileges.

### Caller ID in ISDN Networks

In ISDN networks, caller ID (sometimes called CLID or ICLID for incoming calling line identification) is an analog service offered by a central office (CO) to supply calling party information to subscribers. Caller ID allows the calling party number and name to appear on a device such as a telephone display.

ISDN messages signal call control and are composed of information elements (IEs) that specify screening and presentation indicators. ISDN messages and their IEs are passed in GTD format. GTD format enables transport of signaling data in a standard format across network components and applications. The standard format enables other devices to scan and interpret the data. The SIP network extracts the calling name from the GTD format and sends the calling name information to the SIP customer.

## ISDN and SIP Call Flows Showing the Remote-Party-ID Header

Figure 86 shows the SIP gateway receiving an ISDN Setup message that contains a Display (or Facility) IE indicating the calling name. Receiving the message initiates call establishment.

The Remote-Party-ID header sent by the SIP gateway identifies the calling party and carries presentation and screening information. The Remote-Party-ID header, which can be modified, added, or removed as a call session is being established, enables call participant privacy indication, screening, and verification.

**Figure 86** Calling Name in Display or Facility IE of an ISDN Setup Message

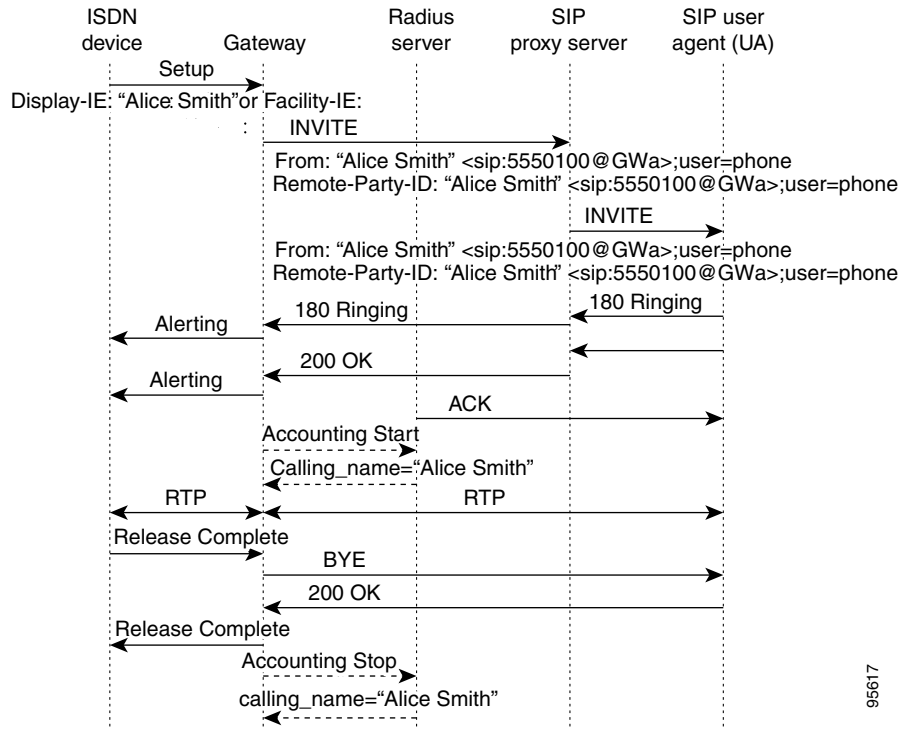
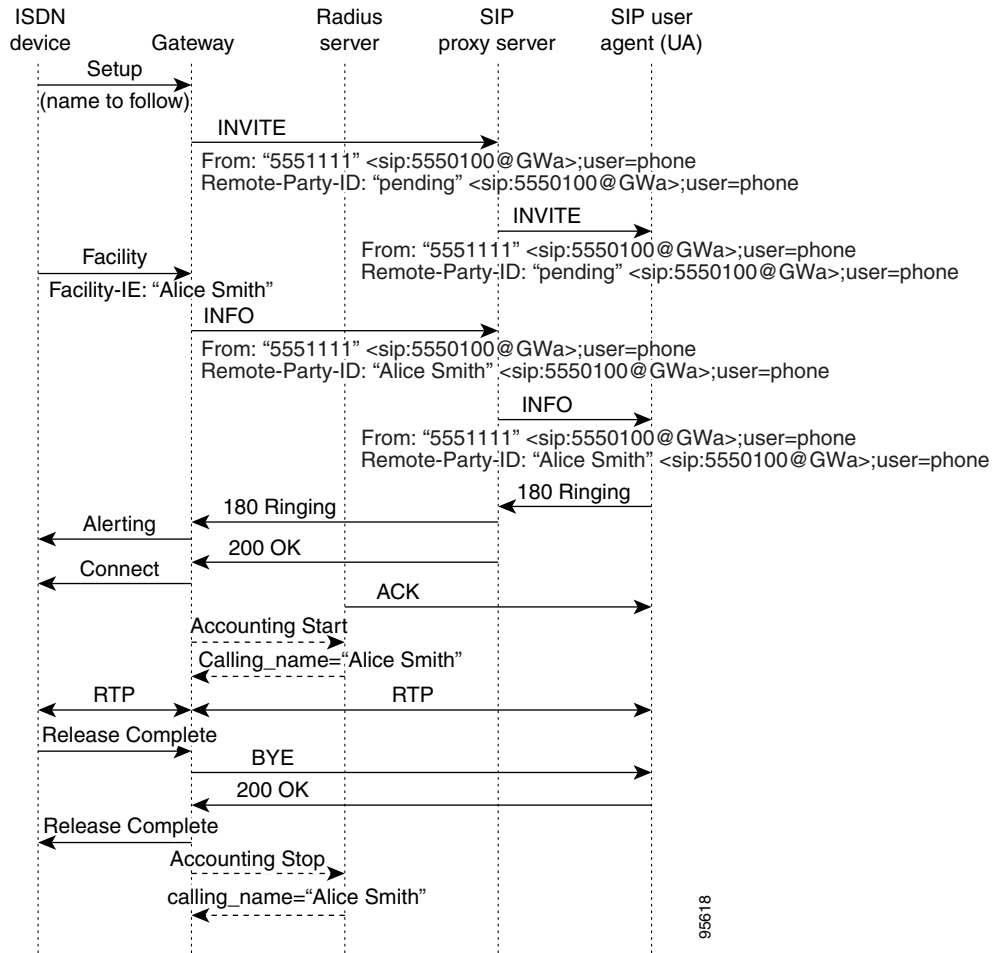

Figure 87 shows that the original ISDN Setup message sent by the ISDN device does not contain a Facility IE. The SIP gateway receives the ISDN Setup message indicating that the calling name is to be delivered in a subsequent ISDN Facility message. The SIP gateway then sets the display name of the Remote-Party-ID to *pending*. The presence of *pending* in a calling Remote-Party-ID of an INVITE denotes that the display name is to follow.

The functionality of a calling name sent in a subsequent message requires that:

- The ISDN switch type has the ability to indicate that the name follows in the next Facility message after the initial ISDN Setup message.
- The SIP gateway has the ability to interpret the subsequent Facility message into a SIP message. The SIP INFO message is used to interpret the Facility received from the ISDN device.

Figure 87 Calling Name in Facility IE of an ISDN Facility Message



## Signal ISDN B-Channel ID to Enable Application Control of Voice Gateway Trunks

The Signal ISDN B-Channel ID to Enable Application Control of Voice Gateway Trunks feature enables call management applications to identify specific ISDN bearer (B) channels used during a voice gateway call for billing purposes. With the identification of the B channel, SIP gateways can enable port-specific features such as voice recording and call transfer.

In Cisco IOS releases prior to 12.3(7)T, fields used to store call leg information regarding the telephony port do not include B channel information. B channel information is used to describe incoming ISDN call legs. The Signal ISDN B-Channel ID to Enable Application Control of Voice Gateway Trunks feature allows SIP and H.323 gateways to receive B-channel information from incoming ISDN calls. The acquired B channel information can be used during call transfer or to route a call.

SIP gateways use the **ds0-num** command to enable receiving the B channel of a telephony call leg. H.323 gateways use a different command, which allows users to run the two protocols on one gateway simultaneously.

**Note**

For information on using this feature on H.323 gateways, see [Configuring H.323 Gateways](#).

For SIP, if the **ds0-num** command is configured, the ISDN B-channel information is carried in the Via header of outgoing SIP requests.

## SIP Carrier Identification Code

SIP gateways can receive and transmit the carrier identification code (CIC) parameter, allowing equal access support over many different networks. CIC enables transmission of the CIC parameter from the SIP network to the ISDN.

The CIC parameter is used in routing tables to identify the network that serves the remote user when a call is routed over many different networks. The parameter is carried in SIP INVITE requests and 302 REDIRECTs, and maps to the ISDN Transit Network Selection Information Element (TNS IE) in the outgoing ISDN SETUP message (see [Figure 88](#)). The TNS IE identifies the requested transportation networks and allows different providers equal access support based on customer choice.

**Figure 88** Path of INVITE request with CIC Parameter to SIP Gateway Receiving and to ISDN

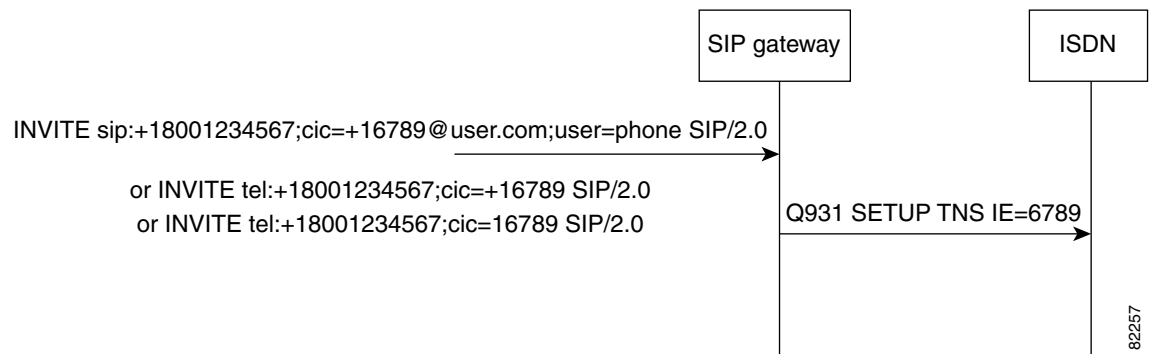

The CIC parameter is supported in SIP URLs, which identify a user's address and appear similar to e-mail addresses: *user@host*. It is also supported in the telephone-subscriber part of a TEL URL, which takes the basic form of *tel:telephone subscriber number*, where *tel* requests the local entity to place a voice call, and *telephone subscriber number* is the number to receive the call.

The CIC parameter can be a three-digit or a four-digit code. However, if it is a three-digit code, it is prefixed by a zero as in the following example:

```
cic=+1234 = TNS IE 0234.
```

## SIP: CLI for Caller ID When Privacy Exists

The SIP: CLI for Caller ID When Privacy Exists feature is comprised of three main components, as follows:

- [SIP: Caller ID Removable to Improve Privacy, page 8](#)
- [SIP: Calling Number Substitution for the Display Name When the Display Name is Unavailable, page 9](#)
- [SIP: Calling Number Passing as Network-Provided or User-Provided, page 10](#)

## SIP: Caller ID Removable to Improve Privacy

The caller ID information is passed through from the ISDN-to-SIP by copying the number in the Calling Party Number information element (IE) in an ISDN Setup message into the Calling Number field of the SIP Remote-Party-ID and From headers.

The Calling Name from the ISDN Display IE is copied into the SIP Display Name field in the SIP Remote-Party-ID and From headers. The Calling Party Number IE contains a Presentation Indicator field that is set to presentation allowed, presentation restricted, number not available due to interworking, or reserved. Presentation allowed and presentation restricted are translated into privacy set to off or privacy set to null, respectively, in the SIP Remote-Party-ID header field.

However, for added privacy, the SIP: CLI for Caller ID When Privacy Exists feature introduces CLI to completely remove the Calling Number and Display Name from an outgoing message's From header if presentation is prohibited. This prohibits sending the SIP Remote Party ID header, because the Cisco gateway does not send SIP Remote-Party ID headers without both a Display Name and Calling Number.



**Note**

The [SIP: Caller ID Removable to Improve Privacy](#) option is available both globally and at the dial-peer level.

See [Figure 89](#) for call flows and [Table 53](#) and [Table 54](#) for additional presentation mapping.

**Figure 89 Call Flow for Blocking Caller ID Information When Privacy Exists**

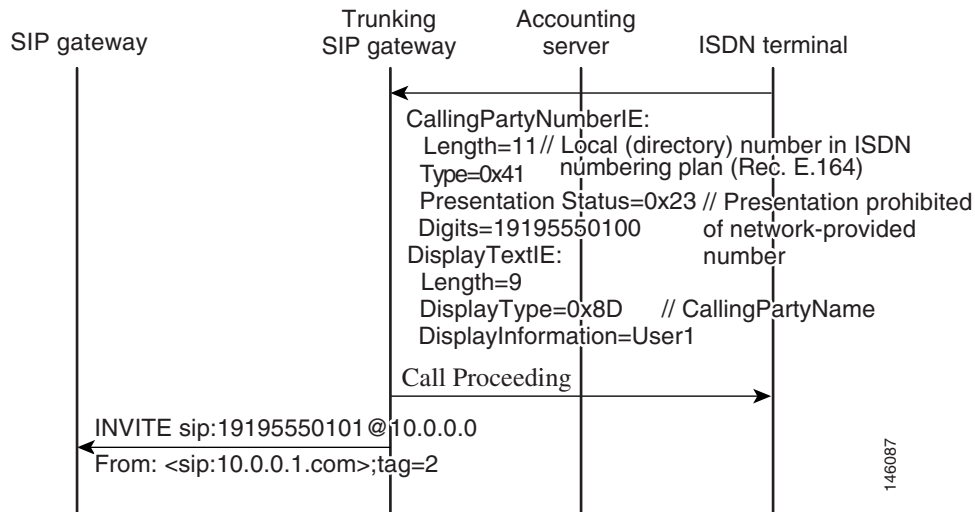

146087

**Table 53** *Presentation to Privacy Mapping with CLI Disabled*

Presentation Indicator	From Remote Party ID (RPID)
Presentation Allowed	From: "User1" <sip:19195550100@10.0.0.0>;tag=1 Remote-Party-ID: "User1" <sip:19195550100@10.0.0.0>;party=calling;privacy=off
Presentation Prohibited	From: "User1" <sip:19195550100@10.0.0.0>;tag=1 Remote-Party-ID: "User1"<sip:19195550100@10.0.0.0>;party=calling;privacy=full

**Table 54** *Presentation to Privacy Mapping with CLI Enabled*

Presentation Indicator	From RPID
Presentation Allowed	From: "User1" <sip:19195550100@10.0.0.0>;tag=1 Remote-Party-ID: "User1"<sip:19195550100@10.0.0.0>;party=calling;privacy=off
Presentation Prohibited	From: <sip:10.0.0.0>;tag=1 Remote Party ID not sent

## SIP: Calling Number Substitution for the Display Name When the Display Name is Unavailable

When the Display information element (IE) in a PSTN-to-SIP call is not available with a Setup message, the Cisco gateway leaves the Display Name field in the SIP Remote-Party-ID and From headers blank.

When presentation is allowed, the SIP: CLI for Caller ID When Privacy Exists feature enables the substitution of the Calling Number for the missing Display Name in the SIP Remote-Party-ID and From headers. Upon receipt of a Setup message where a name to follow is indicated, the Calling Number is not copied into the Display Name.

Also, the SIP Extensions for Caller Identity and Privacy on SIP gateway feature added the ability to hardcode calling name and number in the SIP Remote-Party-ID and From headers. The SIP Extensions for Caller Identify and Privacy feature settings take precedence over the SIP: CLI for Caller ID When Privacy Exists feature settings.



### Note

The [SIP: Calling Number Substitution for the Display Name When the Display Name is Unavailable](#) option is available both globally and at the dial-peer level.

See [Figure 90](#) for the call flow where the Calling Number is substituted for the Display Number.

**Figure 90** Call Flow for Substituting the Calling Number for the Display Name When the Display Name is Unavailable

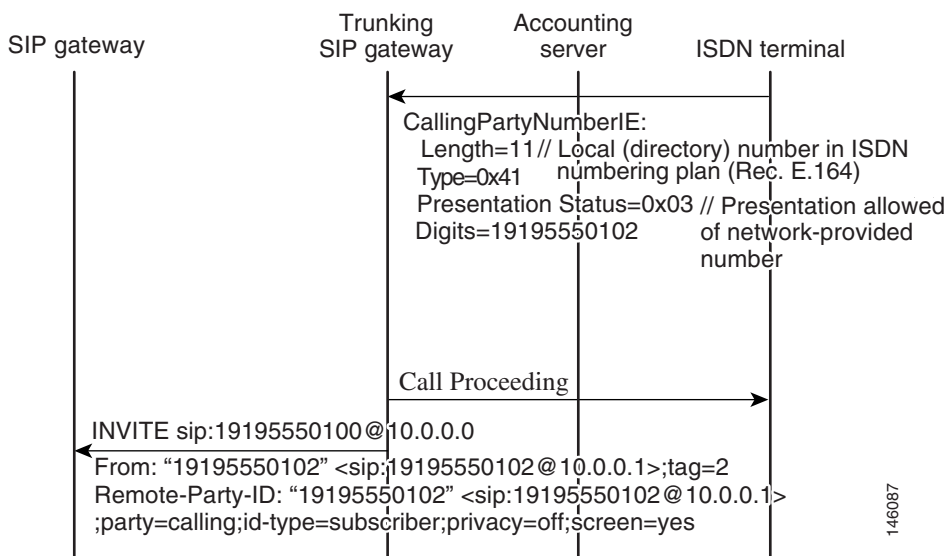

### SIP: Calling Number Passing as Network-Provided or User-Provided

ISDN numbers can be passed along as network-provided or user-provided in an ISDN Calling Party information element (IE) Screening Indicator field. The Cisco gateway automatically sets the Screening Indicator to user-provided in SIP-to-ISDN calls.

The SIP: CLI for Caller ID When Privacy Exists feature allows toggling between user-provided and network-provided ISDN numbers for the screening indicator. Therefore, after bits 1 and 2 are set to reflect network-provided, any existing screening information is lost. However, presentation information in bits 6 and 7 is preserved.



**Note**

The [Call Flow for Passing Through the Calling Number as Network-Provided](#) option is available both globally and at the dial-peer level.

See [Figure 91](#) for the call flow when the calling number is passed along as network-provided.

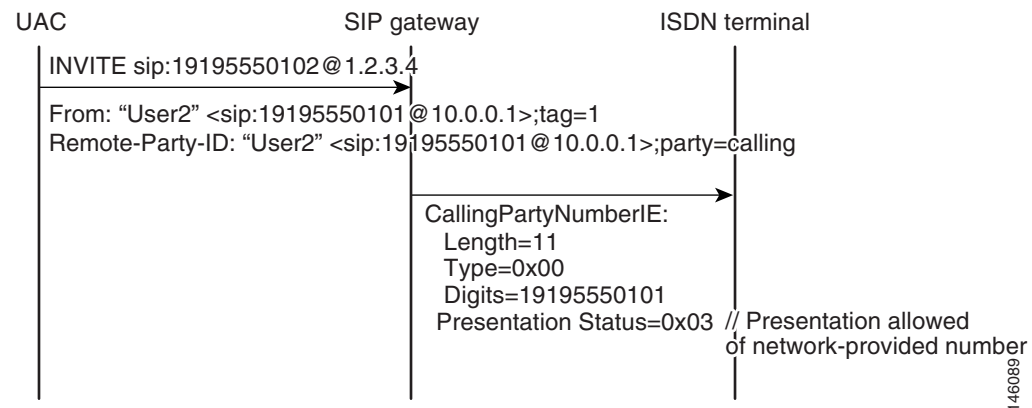
**Figure 91** Call Flow for Passing Through the Calling Number as Network-Provided

## SIP: ISDN Suspend/Resume Support

Suspend and Resume are basic functions of ISDN and ISDN User Part (ISUP) signaling procedures and now are a part of SIP functionality. Suspend is described in ITU Q.764 as a message that indicates a temporary cessation of communication that does not release the call. A Suspend message can be accepted during a conversation. A Resume message is received after a Suspend message and is described in ITU Q.764 as a message that indicates a request to recommence communication. If the calling party requests to release the call, the Suspend and Resume sequence is overridden.

## SIP Call-Hold Process

When a SIP originating gateway receives an ISDN Suspend message, the originating gateway informs the terminating gateway that there is a temporary cessation of media; that is, the call is placed on hold. There are two ways that SIP gateways receive notice of a call hold. The first way is for the originating gateway to use a connection IP address of 0.0.0.0 (c=0.0.0.0) in the Session Description Protocol (SDP). The information in the SDP is sent in a re-Invite to the terminating gateway. The second way is for the originating gateway to use a=sendonly in the SDP of a re-Invite.



### Note

Earlier than Cisco IOS Release 12.3(8)T, a SIP gateway could initiate call hold only by using c=0.0.0.0. As of Cisco IOS Release 12.3(8)T, a gateway can initiate call hold by using either c=0.0.0.0 or a=sendonly.

The purpose of the c=0.0.0.0 line is to notify the terminating gateway to stop sending media packets. When the hold is cancelled and communication is to resume, an ISDN Resume message is sent. The SIP originating gateway takes the call off hold by sending out a re-Invite with the actual IP address of the remote SIP entity in the c= line (in place of 0.0.0.0).

Multiple media fields (m-lines) in the SDP of a re-Invite message are used to indicate media forking, with each m-line representing one media destination. SIP gateways negotiate multiple media streams by using multiple m- and/or c-lines. When an originating gateway receives an ISDN Suspend on a gateway that has negotiated multiple media streams, all of the media streams are placed on hold. The originating gateway sends out a re-Invite that has a c= line that advertises the IP address as 0.0.0.0 on all streams.

The originating gateway also mutes the SIP calls for each media stream so that no media is sent to the terminating gateway. When the originating gateway receives an ISDN Resume, it initiates a re-Invite with the original SDP and takes the call off hold.

If the media inactivity timer is configured on the network, the timer is stopped for all active streams. The purpose of the media inactivity timer is to monitor and disconnect calls if no Real-Time Control Protocol (RTCP) packets are received within a configurable time period. However, on initiating the call hold, the originating gateway disables the media inactivity timer for that particular call, so the call remains active. The terminating gateway behaves in the same way when it receives the call-hold re-Invite from the originating gateway. When the call resumes, the originating gateway re-enables the Media Inactivity Timer.

**Note**

---

For information on the timer, see the [“SIP Media Inactivity Timer” section on page 17](#).

---

All billing and accounting procedures are unaffected by the SIP: ISDN Suspend/Resume Support feature.

## SIP PSTN Transport Using the Cisco Generic Transparency Descriptor

This section contains the following information:

- [SIP ISUP Transparency Using GTD Overview, page 12](#)
- [SIP INFO Message Generation and Serialization, page 13](#)
- [Transporting ISDN Messages in GTD Format, page 13](#)
- [SIP Generation of Multiple Message Bodies, page 14](#)
- [ISUP-to-SIP Message Mapping, page 14](#)

The SIP PSTN Transport Using the Cisco Generic Transparency Descriptor feature adds SIP support for ISDN User Part (ISUP) Transport using Generic Transparency Descriptor (GTD). The ISUP data received on the originating gateway (OGW) is preserved and passed in a common text format to the terminating gateway (TGW).

Feature benefits include the following:

- The ISUP data is reconstructed on the basis of the protocol at the egress side of the network, without any concern for the ISDN or ISUP variant on the ingress side of the network.
- By providing the ISDN or ISUP information in text format, the information can also be used by applications inside the core SIP network. An example of one such application is a route server that can use certain ISDN or ISUP information to make routing decisions.
- The transport of ISUP encapsulated in GTD maintains compatibility with the H.323 protocol.

### SIP ISUP Transparency Using GTD Overview

The SIP PSTN Transport Using the Cisco Generic Transparency Descriptor feature adds SIP support for ISUP transport using GTD. That is, ISUP data received on the OGW is preserved and presented in a common ASCII format to the TGW.

GTD objects can be used to represent ISUP messages, parameters, and R2 signals. These GTD objects are encapsulated into existing signaling protocols, such as SIP, facilitating end-to-end transport. The transport of ISUP encapsulated in GTD ASCII format already exists for H.323; SIP PSTN Transport

Using the Cisco Generic Transparency Descriptor provides feature parity. Using GTD as a transport mechanism for signaling data in Cisco IOS software provides a common format for sharing signaling data between various components in a network and for interworking various signaling protocols.

To attain ISUP transparency in VoIP Networks, the gateway needs to externally interface with the Cisco SC node. The Cisco SC node is the combination of hardware (Cisco PGW 2200 and Cisco SLTs) and signaling controller software that provides the signaling controller function. The Cisco SC node transports the signaling traffic between the SC hosts and the SS7 signaling network. A brief example of the process of an ISDN message containing an ISUP GTD message that comes into the Cisco OGW from a Cisco SC node is described below and shown in [Figure 92](#).

**Figure 92 ISUP Transparency Implementation**

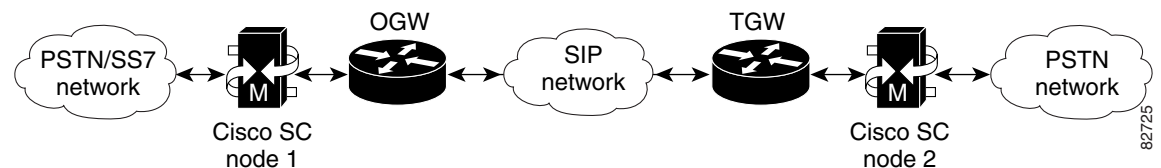

The process in [Figure 92](#) is as follows:

1. Cisco SC node 1 receives an ISUP message from the public switched telephone network (PSTN). This node is now responsible for mapping the ISUP message into a GTD format and encapsulating this GTD body within the ISDN message that is sent to the OGW.
2. The SIP user agent on the OGW extracts the GTD body from the Q931 message and encapsulates it into a corresponding SIP message as a multipart MIME attachment.



**Note** For information on ISUP- to-SIP mapping, see [Table 55 on page 14](#).

3. The SIP message is sent by the OGW over the SIP network to the TGW.
4. The TGW encapsulates the GTD in the outgoing ISDN message which is sent to SC node 2. The SC then remaps the GTD to ISUP before passing it to the PSTN.

## SIP INFO Message Generation and Serialization

The SIP PSTN Transport Using the Cisco Generic Transparency Descriptor (GTD) feature adds client and server support for the SIP INFO message in all phases of a call. INFO messages are used to carry ISUP messages that were encapsulated into GTD format, but that do not have a specific mapping to any SIP response or request. These ISUP messages can be received in any phase of the call.



**Note** For specific mapping messages, see the [“ISUP-to-SIP Message Mapping”](#) section on page 14.

The gateway does not support sending out overlapping SIP INFO messages. For example, a second INFO message cannot be sent out while one is still outstanding. Multiple PSTN messages that map to SIP INFO messages are sent out serially.

## Transporting ISDN Messages in GTD Format

Support for ISDN messages in GTD format is limited to the ISDN Setup message. Only the following parameters are encoded and decoded:

- Originating-line information
- Bearer capability
- Calling-party number
- Called-party number
- Redirecting number

Whereas ISDN to GTD parameter mapping is enabled by default, you must configure the gateway to transport ISUP messages through SIP signaling.

The ISDN parameters can be transported using either GTD or SIP headers. Before the SIP PSTN Transport Using the Cisco Generic Transparency Descriptor feature, only SIP headers provided ISDN parameters. For instance, the user portion of a SIP From header can carry the ISDN Calling Party information element.

SIP headers generally contain the same information that is provided by GTD, because the headers are built on the OGW using information gained from the PSTN. However, there are situations in which the data may be in conflict. The inconsistent data occurs if the header was updated by an intermediate proxy or application server. In cases of conflict, the SIP header is used to construct the ISDN parameters on the TGW, because it generally contains the most recent information.

## SIP Generation of Multiple Message Bodies

Before this feature, the SIP gateway handled only SDP as a message body type. With SIP PSTN Transport Using the Cisco Generic Transparency Descriptor, it is now possible for the gateway to generate and properly format messages that contain both SDP and GTD message body types.

Any SIP message that contains both SDP and GTD bodies may be large enough to require link-level fragmentation when User Datagram Protocol (UDP) transport is used, which could result in excessive retransmissions. TCP transport can be used if fragmentation becomes a performance issue.

## ISUP-to-SIP Message Mapping

SIP PSTN Transport Using the Cisco Generic Transparency Descriptor attempts to map particular ISUP messages to an equivalent SIP message. This mapping is defined in [Table 55](#).

**Table 55** Mapping of Supplemental ISUP Messages to SIP Messages

ISUP Message Type	ISDN (NI2C) Message Type	SIP Message Type
ACM	Alerting	180/183 Progress messages
ANM	Connect	200 OK to the INVITE request
CON	Connect	200 OK to the INVITE request
CPG	Progress	180/183 Progress messages
IAM	Setup	INVITE request
REL	Disconnect	BYE/CANCEL/4xx/5xx/6xx
RES	Resume	INVITE request
SUS	Suspend	INVITE

**Note**

There are many other PSTN or SS7 messages that are mapped into GTD formats within an ISDN message by the SC node. If the mapping is not listed in [Table 55](#), the message is treated with the SIP INFO method.

## How to Configure SIP ISDN Support Features

This section contains the following procedures:

- [Configuring ISDN Calling Name Display](#), page 15
- [Configuring Signal ISDN B-Channel ID to Enable Application Control of Voice Gateway Trunks](#), page 17
- [Configuring SIP Carrier Identification Code](#), page 18
- [Configuring SIP: CLI for Caller ID When Privacy Exists](#), page 19
- [Configuring SIP: ISDN Suspend/Resume Support](#), page 27
- [Configuring SIP PSTN Transport Using the Cisco Generic Transparency Descriptor](#), page 28
- [Verifying SIP ISDN Support Features](#), page 29
- [Troubleshooting Tips](#), page 30

**Note**

- Before you perform a procedure, familiarize yourself with the following information:
  - [“Prerequisites for SIP ISDN Support”](#) section on page 2
  - [“Restrictions for SIP ISDN Support”](#) section on page 3
- For help with a procedure, see the troubleshooting section listed above.

## Configuring ISDN Calling Name Display

To enable SIP IP phones to display caller-name identification for calls that originate on an ISDN network, perform the following task.

### SUMMARY STEPS

1. **enable**
2. **configure terminal**
3. **voice service voip**
4. **signaling forward**
5. **exit**
6. **interface serial**
7. **isdn supp-service name calling**
8. **exit**

## DETAILED STEPS

	Command or Action	Purpose
Step 1	<b>enable</b>  <b>Example:</b> Router> Enable	Enables privileged EXEC mode. Enter your password if prompted.
Step 2	<b>configure terminal</b>  <b>Example:</b> Router# configure terminal	Enters global configuration mode.
Step 3	<b>voice service voip</b>  <b>Example:</b> Router(config)# voice service voip	Enters voice-service configuration mode.
Step 4	<b>signaling forward {none   unconditional}</b>  <b>Example:</b> Router(conf-voi-serv)# signaling forward unconditional	Specifies whether or not the originating gateway (OGW) forwards the signaling payload to the terminating gateway (TGW). Keywords are as follows: <ul style="list-style-type: none"> <li>• <b>none</b>—Prevent the gateway from passing the signaling payload to the TGW.</li> <li>• <b>unconditional</b>—Forward the signaling payload received in the OGW to the TGW, even if the attached external route server has modified the GTD payload.</li> </ul>
Step 5	<b>exit</b>  <b>Example:</b> Router(conf-voi-serv)# exit	Exits the current mode.
Step 6	<b>interface serial slot/port:timeslot</b>  <b>Example:</b> Router(config)# interface serial 1/0:23	Specifies a serial interface created on a channelized E1 or channelized T1 controller. You must explicitly specify a serial interface. Arguments are as follows: <ul style="list-style-type: none"> <li>• <i>slotport</i>—Slot and port where the channelized E1 or T1 controller is located. The slash is required.</li> <li>• <i>:time-slot</i>—For ISDN, the D-channel time slot, which is the 23 channel for channelized T1 and the 15 channel for channelized E1. The colon is required.</li> </ul>
Step 7	<b>isdn supp-service name calling</b>  <b>Example:</b> Router(config-if)# isdn supp-service name calling	Sets the calling-name display parameters sent out an ISDN serial interface.
Step 8	<b>exit</b>  <b>Example:</b> Router(config-if)# exit	Exits the current mode.

## Configuring Signal ISDN B-Channel ID to Enable Application Control of Voice Gateway Trunks

To configure the Signal ISDN B-Channel ID to Enable Application Control of Voice Gateway Trunks feature, perform the following steps.

### SUMMARY STEPS

1. **enable**
2. **configure terminal**
3. **voice service voip**
4. **sip**
5. **ds0-num**
6. **exit**

### DETAILED STEPS

	Command or Action	Purpose
Step 1	<b>enable</b>  <b>Example:</b> Router> Enable	Enables privileged EXEC mode. Enter your password if prompted.
Step 2	<b>configure terminal</b>  <b>Example:</b> Router# configure terminal	Enters global configuration mode.
Step 3	<b>voice service voip</b>  <b>Example:</b> Router(config)# voice service voip	Enters VoIP voice-service configuration mode.
Step 4	<b>sip</b>  <b>Example:</b> Router(conf-voi-serv) # sip	Enters SIP configuration mode.
Step 5	<b>ds0-num</b>  <b>Example:</b> Router(conf-serv-sip) # ds0-num	Adds B-channel information to outgoing SIP messages.
Step 6	<b>exit</b>  <b>Example:</b> Router(conf-serv-sip) # exit	Exits the current mode.

# Configuring SIP Carrier Identification Code

## SUMMARY STEPS

1. **debug ccsip messages**
2. **debug isdn q931**

## DETAILED STEPS

### Step 1 **debug ccsip messages**

Use this command to show all SIP SPI message tracing. Use it on a terminating gateway to verify the incoming CIC parameter.

#### Examples:

This example shows output of an INVITE request that uses a SIP URL and contains a CIC parameter:

```
Router# debug ccsip messages

00:03:01: Received:
INVITE sip:5550101;cic=+16789@172.18.202.60:5060;user=phone SIP/2.0
Via: SIP/2.0/UDP 172.18.202.62:5060
From: <sip:4440001@172.18.202.62>;tag=24176150-1A11
To: <sip:5550101@172.18.202.60;user=phone>
Date: Mon, 08 Mar 1993 00:11:51 GMT
Call-ID: 590F6480-1A7011CC-80B5CC57-1D726644@172.18.202.62
Supported: 100rel
Cisco-Guid: 1494180992-443552204-2159266903-494036548
User-Agent: Cisco-SIPGateway/IOS-12.x
CSeq: 101 INVITE
Max-Forwards: 6
Timestamp: 731549511
Contact: <sip:4440001@172.18.202.62:5060;user=phone>
Expires: 180
Allow-Events: telephone-event, x-com-cisco-telephone-event,
x-com-cisco-fail-telephone-event
Content-Type: application/sdp
Content-Length: 160
```

The following shows output of an INVITE request that uses a TEL URL and contains a CIC parameter:

```
Router# debug ccsip messages

00:01:00: Received:
INVITE tel:+5550101;cic=+16789 SIP/2.0
Via: SIP/2.0/UDP 172.18.202.62:5060
From: <sip:4440001@172.18.202.62>;tag=24158B04-1D45
To: <sip:5550101@172.18.202.60;user=phone>
Date: Mon, 08 Mar 1993 00:09:51 GMT
Call-ID: 114C6D4C-1A7011CC-80B0CC57-1D726644@172.18.202.62
Supported: 100rel
Cisco-Guid: 290221388-443552204-2158939223-494036548
User-Agent: Cisco-SIPGateway/IOS-12.x
CSeq: 101 INVITE
Max-Forwards: 6
Timestamp: 731549391
Contact: <sip:4440001@172.18.202.62:5060;user=phone>
Expires: 180
Allow-Events: telephone-event, x-com-cisco-telephone-event,
x-com-cisco-fail-telephone-event
```

```
Content-Type: application/sdp
Content-Length: 160
```

## Step 2 **debug isdn q931**

Use this command to display information about call setup and teardown of ISDN network connections (layer 3) between the local router (user side) and the network. Use it to verify the contents of the CIC parameter and the TNS IE.

### **Example:**

This example shows output of an outgoing call SETUP that contains the TNS IE. Output is the same for either a SIP or TEL URL.

```
Router# debug isdn q931
```

```
00:01:00: ISDN Se2/0:23: TX -> SETUP pd = 8 callref = 0x0001
00:01:00: Bearer Capability i = 0x8090A2
00:01:00: Channel ID i = 0xA98397
00:01:00: Calling Party Number i = 0x0081, '4440001', Plan:Unknown, Type:Unknown
00:01:00: Called Party Number i = 0xA8, '5550101', Plan:National, Type:National
00:01:00: Transit Net Select i = 0xA1, '6789'
```

## Configuring SIP: CLI for Caller ID When Privacy Exists

This section contains the following procedures:

- [Configuring SIP: Blocking Caller ID Information Globally When Privacy Exists, page 19](#) (optional)
- [Configuring Dial-Peer Level SIP: Blocking of Caller ID Information When Privacy Exists, page 21](#) (optional)
- [Configuring Globally the SIP: Calling Number for Display Name Substitution When Display Name Is Unavailable, page 21](#) (optional)
- [Configuring Dial-Peer-Level SIP: Substitution of the Calling Number for Display Name When the Display Name Is Unavailable, page 22](#) (optional)
- [Configuring Globally the SIP: Pass-Through of the Passing Calling Number as Network-Provided, page 23](#) (optional)
- [Configuring at the Dial-Peer Level the SIP: Pass-Through of Passing the Calling Number as Network-Provided, page 24](#) (optional)
- [Configuring Globally the SIP: Pass-Through of the Passing Calling Number as User-Provided, page 25](#) (optional)
- [Configuring at the Dial-Peer Level the SIP: Pass-Through of Passing the Calling Number as User-Provided, page 26](#) (optional)

## Configuring SIP: Blocking Caller ID Information Globally When Privacy Exists

The Call-ID information is private information. In ISDN there is a private setting that can be set to protect this information. However, whenever SIP gets the Call-ID information, it does not hide the private information, rather, it just sets a field to reflect that it is private and not to display it on a Call-ID display. But, the data is still viewable in the SIP message requests. This option allows the Cisco gateway to delete the Call-ID information from the SIP message requests so it cannot be read on the network.

Upon receiving an ISDN Setup message with the calling-party information element, the Cisco gateway translates the presentation indicator to set privacy to full for restricted presentation or to set privacy to off for unrestricted presentation in the Remote-Party-ID header field. The SIP: CLI for Caller ID When Privacy Exists feature introduces a CLI switch that either allows stripping the Calling Number and Display Name from the From and Remote-Party-ID fields in the SIP message requests or passes on the information. However, in cases of unrestricted presentation, the gateway passes the caller ID information, regardless of the CLI setting.

The global commands to strip the Calling Name and Calling Number from the Remote-Party-ID and From headers are as follows:

## SUMMARY STEPS

1. **enable**
2. **configure terminal**
3. **voice service voip**
4. **clid strip pi-restrict all**
5. **exit**

## DETAILED STEPS

	Command or Action	Purpose
Step 1	<b>enable</b>  <b>Example:</b> Router> enable	Enables privileged EXEC mode. <ul style="list-style-type: none"> <li>• Enter your password if prompted.</li> </ul>
Step 2	<b>configure terminal</b>  <b>Example:</b> Router# configure terminal	Enters global configuration mode.
Step 3	<b>voice service voip</b>  <b>Example:</b> Router(config)# voice service voip	Enters voice-service-VoIP configuration mode.
Step 4	<b>clid strip pi-restrict all</b>  <b>Example:</b> Router(config-voip-serv)# clid strip pi-restrict all	Enters block call ID information when privacy exists in global configuration mode.
Step 5	<b>exit</b>  <b>Example:</b> Router(config-voip-serv)# exit	Exits the current mode.

## Configuring Dial-Peer Level SIP: Blocking of Caller ID Information When Privacy Exists

The dial-peer specific command to strip the Calling Number from the Remote-Party-ID and From headers is as follows:

### SUMMARY STEPS

1. **enable**
2. **configure terminal**
3. **dial-peer voice *dial-peer-number* voip**
4. **clid strip pi-restrict all**
5. **exit**

### DETAILED STEPS

	Command or Action	Purpose
Step 1	<b>enable</b>  <b>Example:</b> Router> enable	Enables privileged EXEC mode. <ul style="list-style-type: none"> <li>• Enter your password if prompted.</li> </ul>
Step 2	<b>configure terminal</b>  <b>Example:</b> Router# configure terminal	Enters global configuration mode.
Step 3	<b>dial-peer voice <i>dial-peer-number</i> voip</b>  <b>Example:</b> Router(config)# dial-peer voice 100 voip	Enters dial-peer configuration mode.
Step 4	<b>clid strip pi-restrict all</b>  <b>Example:</b> Router(config-dial-peer)# clid strip pi-restrict all	Enters block call ID information when privacy exists in dial-peer configuration mode.
Step 5	<b>exit</b>  <b>Example:</b> Router# exit	Exits the current mode.

## Configuring Globally the SIP: Calling Number for Display Name Substitution When Display Name Is Unavailable

When this is enabled, if there is no Display Name field but there is a number, it copies the number into the Display Name field, so the number is displayed on the recipient's Call-ID display.

The Cisco gateway omits the Display Name field if no display information is received. This feature also introduces a CLI switch that allows the Calling Number to be copied into the Display Name field, as long as presentation is not prohibited.

The steps for substituting the Calling Number for the Display Name when it is unavailable in the Remote-Party-ID and From headers are as follows:

## SUMMARY STEPS

1. **enable**
2. **configure terminal**
3. **voice service voip**
4. **clid substitute name**
5. **exit**

## DETAILED STEPS

	Command or Action	Purpose
Step 1	<b>enable</b>  <b>Example:</b> Router> enable	Enables privileged EXEC mode. <ul style="list-style-type: none"> <li>• Enter your password if prompted.</li> </ul>
Step 2	<b>configure terminal</b>  <b>Example:</b> Router# configure terminal	Enters global configuration mode.
Step 3	<b>voice service voip</b>  <b>Example:</b> Router(config)# voice service voip	Enters voice-service-VoIP configuration mode.
Step 4	<b>clid substitute name</b>  <b>Example:</b> Router(config-voip-serv)# clid substitute name	Substitutes the calling number for the display name when the display name is unavailable in the global configuration mode.
Step 5	<b>exit</b>  <b>Example:</b> Router(config-voip-serv)# exit	Exits the current mode.

## Configuring Dial-Peer-Level SIP: Substitution of the Calling Number for Display Name When the Display Name Is Unavailable

The dial-peer-specific steps for substituting the Calling Number for the Display Name when it is unavailable in the Remote-Party-ID and From headers are as follows:

## SUMMARY STEPS

1. **enable**
2. **configure terminal**

3. **dial-peer voice *dial-peer-number* voip**
4. **clid substitute name**
5. **exit**

## DETAILED STEPS

	Command or Action	Purpose
Step 1	<b>enable</b>  <b>Example:</b> Router> enable	Enables privileged EXEC mode. <ul style="list-style-type: none"> <li>• Enter your password if prompted.</li> </ul>
Step 2	<b>configure terminal</b>  <b>Example:</b> Router# configure terminal	Enters global configuration mode.
Step 3	<b>dial-peer voice <i>dial-peer-number</i> voip</b>  <b>Example:</b> Router(config-dial-peer)# dial-peer voice 100 voip	Enters dial-peer configuration mode.
Step 4	<b>clid substitute name</b>  <b>Example:</b> Router(config-dial-peer)# clid substitute name	Substitutes the calling number for the display name when the display name is unavailable in dial-peer configuration mode.
Step 5	<b>exit</b>  <b>Example:</b> Router(config-dial-peer)# exit	Exits the current mode.

## Configuring Globally the SIP: Pass-Through of the Passing Calling Number as Network-Provided

This field shows whether the Call-ID information was supplied by the network or not. This is for screening purposes.

Formerly the Calling Number from the session initiation protocol to public switched telephone network (SIP-to-PSTN) was always translated to user-provided. This feature introduces a CLI switch to toggle between branding numbers as user-provided or network-provided.

The steps for globally setting set the Screening Indicator to network-provided are as follows:

## SUMMARY STEPS

1. **enable**
2. **configure terminal**
3. **voice service voip**
4. **clid network-provided**

5. exit

## DETAILED STEPS

	Command or Action	Purpose
Step 1	<b>enable</b>  <b>Example:</b> Router> enable	Enables privileged EXEC mode. <ul style="list-style-type: none"> <li>• Enter your password if prompted.</li> </ul>
Step 2	<b>configure terminal</b>  <b>Example:</b> Router# configure terminal	Enters global configuration mode.
Step 3	<b>voice service voip</b>  <b>Example:</b> Router(config)# voice service voip	Enters voice-service-VoIP configuration mode.
Step 4	<b>clid network-provided</b>  <b>Example:</b> Router(config-voip-serv)# clid network-provided	Enters the network-provided calling number in voice-service-VoIP configuration mode.
Step 5	<b>exit</b>  <b>Example:</b> Router(config-voip-serv)# exit	Exits the current mode.

## Configuring at the Dial-Peer Level the SIP: Pass-Through of Passing the Calling Number as Network-Provided

The dial-peer specific command to set the Screening Indicator to network-provided is as follows:

### SUMMARY STEPS

1. enable
2. configure terminal
3. dial-peer voice *dial-peer-number* voip
4. clid network-provided
5. exit

## DETAILED STEPS

	Command or Action	Purpose
Step 1	<b>enable</b>  <b>Example:</b> Router> enable	Enables privileged EXEC mode. <ul style="list-style-type: none"> <li>Enter your password if prompted.</li> </ul>
Step 2	<b>configure terminal</b>  <b>Example:</b> Router# configure terminal	Enters global configuration mode.
Step 3	<b>dial-peer voice <i>dial-peer-number</i> voip</b>  <b>Example:</b> Router(config)# dial-peer voice 100 voip	Enters dial-peer configuration mode.
Step 4	<b>clid network-provided</b>  <b>Example:</b> Router(config-dial-peer)# clid network-provided	Enters the network-provided calling number in dial-peer configuration mode.
Step 5	<b>exit</b>  <b>Example:</b> Router(config-dial-peer)# exit	Exits the current mode.

## Configuring Globally the SIP: Pass-Through of the Passing Calling Number as User-Provided

The steps for globally setting set the Screening Indicator to user-provided are as follows:

### SUMMARY STEPS

1. **enable**
2. **configure terminal**
3. **voice service voip**
4. **no clid network-provided**
5. **exit**

## DETAILED STEPS

	Command or Action	Purpose
Step 1	<b>enable</b>  <b>Example:</b> Router> enable	Enables privileged EXEC mode. <ul style="list-style-type: none"> <li>Enter your password if prompted.</li> </ul>
Step 2	<b>configure terminal</b>  <b>Example:</b> Router# configure terminal	Enters global configuration mode.
Step 3	<b>voice service voip</b>  <b>Example:</b> Router(config)# voice service voip	Enters voice-service-VoIP configuration mode.
Step 4	<b>no clid network-provided</b>  <b>Example:</b> Router(config-voip-serv)# no clid network-provided	Enters the network-provided calling number in voice-service-VoIP configuration mode.
Step 5	<b>exit</b>  <b>Example:</b> Router(config-voip-serv)# exit	Exits the current mode.

## Configuring at the Dial-Peer Level the SIP: Pass-Through of Passing the Calling Number as User-Provided

The dial-peer specific command to set the Screening Indicator to user-provided is as follows:

## SUMMARY STEPS

1. **enable**
2. **configure terminal**
3. **dial-peer voice *dial-peer-number* voip**
4. **no clid network-provided**
5. **exit**

## DETAILED STEPS

	Command or Action	Purpose
Step 1	<b>enable</b>  <b>Example:</b> Router> enable	Enables privileged EXEC mode. <ul style="list-style-type: none"> <li>Enter your password if prompted.</li> </ul>
Step 2	<b>configure terminal</b>  <b>Example:</b> Router# configure terminal	Enters global configuration mode.
Step 3	<b>dial-peer voice dial-peer-number voip</b>  <b>Example:</b> Router(config)# dial-peer voice 100 voip	Enters dial-peer configuration mode.
Step 4	<b>no clid network-provided</b>  <b>Example:</b> Router(config-dial-peer)# no clid network-provided	Enters the user-provided calling number in dial-peer configuration mode.
Step 5	<b>exit</b>  <b>Example:</b> Router(config-dial-peer)# exit	Exits the current mode.

## Configuring SIP: ISDN Suspend/Resume Support

Suspend and Resume functionality is enabled by default. However, the functionality is also configurable. To configure Suspend and Resume for all dial peers on the VoIP network, perform the steps below on both originating and terminating gateways.

### SUMMARY STEPS

1. **enable**
2. **configure terminal**
3. **sip-ua**
4. **suspend-resume**
5. **exit**

## DETAILED STEPS

	Command or Action	Purpose
Step 1	<b>enable</b>  <b>Example:</b> Router> Enable	Enables privileged EXEC mode. Enter your password if prompted.
Step 2	<b>configure terminal</b>  <b>Example:</b> Router# configure terminal	Enters global configuration mode.
Step 3	<b>sip-ua</b>  <b>Example:</b> Router(config)# sip-ua	Enters SIP user-agent configuration mode.
Step 4	<b>suspend-resume</b>  <b>Example:</b> Router(config-sip-ua)# suspend-resume	Enables support for Suspend and Resume.
Step 5	<b>exit</b>  <b>Example:</b> Router(config-sip-ua)# exit	Exits the current mode.

## Configuring SIP PSTN Transport Using the Cisco Generic Transparency Descriptor

To forward the GTD payload to the gateway either for all dial peers on the VoIP network or for individual dial peers, perform the following steps.

### Prerequisites

- Configure the Cisco PGW2200 to encapsulate SS7 ISUP messages in GTD format before using the **signaling forward** command with the Cisco PGW 2200 signaling controller on the Cisco gateway.

### SUMMARY STEPS

1. **enable**
2. **configure terminal**
3. **voice service voip** or **signaling forward**
4. **signaling forward**
5. **exit**

## DETAILED STEPS

	Command or Action	Purpose
Step 1	<p><code>enable</code></p> <p><b>Example:</b> Router&gt; Enable</p>	Enables privileged EXEC mode. Enter your password if prompted.
Step 2	<p><code>configure terminal</code></p> <p><b>Example:</b> Router# configure terminal</p>	Enters global configuration mode.
Step 3	<p><code>voice service voip</code></p> <p><b>Example:</b> Router(config)# voice service voip</p> <p>OR</p> <p><code>dial-peer voice tag {pots   voip   mmoip   vofr   voatm}</code></p> <p><b>Example:</b> Router(config)# dial-peer voice 100 voip</p>	<p>Enters one of the following configuration modes:</p> <ul style="list-style-type: none"> <li>• Voice-service configuration mode for all dial peers on the VoIP network</li> <li>• Dial-peer voice configuration mode for an individual dial peer</li> </ul>
Step 4	<p><code>signaling forward {none   unconditional}</code></p> <p><b>Example:</b> Router(conf-voi-serv)# signaling forward unconditional</p>	<p>Specifies whether or not the OGW forwards the signaling payload to the TGW. Keywords are as follows:</p> <ul style="list-style-type: none"> <li>• <b>none</b>—Prevent the gateway from passing the signaling payload to the TGW.</li> <li>• <b>unconditional</b>—Forward the signaling payload received in the OGW to the TGW, even if the attached external route server has modified it.</li> </ul> <p><b>Note</b> The <b>conditional</b> keyword is not supported for SIP configuration. If you specify that keyword, the gateway treats it as if you had specified <b>none</b>.</p>
Step 5	<p><code>exit</code></p> <p><b>Example:</b> Router(conf-voi-serv)# exit</p>	Exits the current mode.

## Verifying SIP ISDN Support Features

To verify configuration of SIP ISDN support features, perform the following steps as appropriate (commands are listed in alphabetical order).

## SUMMARY STEPS

1. show dial-peer voice

2. **show running-config**
3. **show sip-ua status**

## DETAILED STEPS

### Step 1 **show running-config**

Use this command to display the configuration and verify that the correct dial peers were changed.

### Step 2 **show dial-peer voice**

Use this command, for each dial peer configured, to verify that the dial-peer configuration is correct.

### Step 3 **show sip-ua status**

Use this command to display whether Suspend and Resume support is enabled or disabled.

The following sample output shows that Suspend and Resume support is enabled.

```
Router# show sip-ua status

SIP User Agent Status
SIP User Agent for UDP : ENABLED
SIP User Agent for TCP : ENABLED
SIP User Agent bind status(signaling): DISABLED
SIP User Agent bind status(media): DISABLED
SIP max-forwards : 6
SIP DNS SRV version: 1 (rfc 2052)
SDP application configuration:
  Version line (v=) required
  Owner line (o=) required
  Session name line (s=) required
  Timespec line (t=) required
Media supported: audio image
Network types supported: IN
Address types supported: IP4
Transport types supported: RTP/AVP udpt1
SIP support for ISDN SUSPEND/RESUME: ENABLED
```

## Troubleshooting Tips



### Note

For general troubleshooting tips and a list of important **debug** commands, see the [“General Troubleshooting Tips”](#) section on page 18.

- Make sure that you can make a voice call.
- Use the **debug ccsip messages** command as shown in the examples below.
- Use the **debug ccsip messages** command to enable traces for SIP messages, such as those that are exchanged between the SIP user-agent client (UAC) and the access server.
- Use the **debug isdn q931** command to display information about call setup and teardown of ISDN network connections (Layer 3) between the local router (user side) and the network.

Following is sample output for some of these commands:

- [Sample Output for the debug ccsip messages Command, page 31](#)

**Sample Output for the debug ccsip messages Command**

The following is a sample INVITE request with B-channel information added as an extension parameter “x-ds0num” to the Via header. The format of the B-channel billing information is: 0 is the D-channel ID, 0 is the T1 controller, and 1 is the B-channel.

```
Router# debug ccsip messages

INVITE sip:3100802@172.18.193.99:5060 SIP/2.0
Via: SIP/2.0/UDP 172.18.193.100:5060;x-ds0num="ISDN 0:D 0:DS1 1:DS0"
From: <sip:3100801@172.18.193.100>;tag=21AC4-594
To: <sip:3100802@172.18.193.99>
Date: Thu, 28 Dec 2000 16:15:28 GMT
Call-ID: 7876AC6C-DC1311D4-8005DBCA-A25DA994@172.18.193.100
Supported: 100rel
Cisco-Guid: 1981523172-3692237268-2147670986-2724047252
User-Agent: Cisco-SIPGateway/IOS-12.x
Allow: INVITE, OPTIONS, BYE, CANCEL, ACK, PRACK, COMET, REFER, SUBSCRIBE, NOTIFY, INFO
CSeq: 101 INVITE
Max-Forwards: 6
Remote-Party-ID: <sip:3100801@172.18.193.100>;party=calling;screen=no;privacy=off
Timestamp: 978020128
Contact: <sip:3100801@172.18.193.100:5060>
Expires: 300
Allow-Events: telephone-event
Content-Type: application/sdp
Content-Length: 254
^M
v=0
o=CiscoSystemsSIP-GW-UserAgent 45 7604 IN IP4 172.18.193.100
s=SIP Call
c=IN IP4 172.18.193.100
t=0 0
m=audio 19492 RTP/AVP 18 0
c=IN IP4 172.18.193.100
a=rtpmap:18 G729/8000
a=fmtp:18 annexb=no
a=rtpmap:0 PCMU/8000
```

The following sample INVITE request shows the Via header if the incoming trunk is T3. The format of the B-channel billing information is: 7/0 is the T3 controller, 1 is the T1 controller, and 2 is the B channel.

```
Router# debug ccsip messages

Via: SIP/2.0/UDP 172.18.193.120:5060; x-ds0num="ISDN 7/0:D 1:D1 2:DS0"
```

## Configuration Examples for SIP ISDN Support Features

This section provides the following configuration examples:

- [ISDN Calling Name Display: Examples, page 32](#)
- [Signal ISDN B-Channel ID to Enable Application Control of Voice Gateway Trunks: Example, page 35](#)
- [SIP Carrier Identification Code: Examples, page 36](#)
- [SIP: CLI for Caller ID When Privacy Exists: Examples, page 38](#)
- [SIP: ISDN Suspend/Resume Support: Example, page 47](#)
- [SIP PSTN Transport Using the Cisco Generic Transparency Descriptor: Examples, page 50](#)

## ISDN Calling Name Display: Examples

**Note**

IP addresses and hostnames in examples are fictitious.

```

Router# show running-config

Building configuration...

Current configuration : 3845 bytes
!
version 12.3
service timestamps debug datetime msec
service timestamps log uptime
no service password-encryption
!
boot-start-marker
boot-end-marker
!
no logging buffered
!
resource-pool disable
clock timezone GMT 5
clock summer-time GMT recurring
!

no aaa new-model
ip subnet-zero
ip tcp path-mtu-discovery
ip name-server 172.18.192.48
!
isdn switch-type primary-ni
isdn voice-call-failure 0
isdn alert-end-to-end
!
voice call send-alert
!
voice service voip
  signaling forward unconditional
  sip
!
fax interface-type fax-mail
!
controller T1 0
  framing esf
  crc-threshold 0
  clock source line primary
  linecode b8zs
  pri-group timeslots 1-24
  description lucent_pbx
!
controller T1 1
  shutdown
  framing esf
  crc-threshold 0
  linecode ami
  description summa_pbx
!
controller T1 2
  shutdown

```

```
framing esf
crc-threshold 0
linecode ami
!
controller T1 3
framing esf
crc-threshold 0
clock source line secondary 1
linecode b8zs
pri-group timeslots 1-24
!
translation-rule 100
Rule 1 ^1 1 ANY national
Rule 2 2% 2 ANY unknown
Rule 4 4% 4 ANY unknown
Rule 5 5% 5 ANY unknown
Rule 6 6% 6 ANY unknown
Rule 7 7% 7 ANY unknown
Rule 8 8% 8 ANY unknown
Rule 9 9% 9 ANY unknown
!
interface Ethernet0
ip address 172.18.193.100 255.255.255.0
no ip route-cache
no ip mroute-cache
ip rsvp bandwidth 1 1
!
interface Serial0:23
no ip address
isdn switch-type primary-ni
isdn incoming-voice modem
isdn guard-timer 3000
isdn supp-service name calling
isdn disconnect-cause 1
fair-queue 64 256 0
no cdp enable
!
interface Serial3:23
no ip address
isdn switch-type primary-ni
isdn protocol-emulate network
isdn incoming-voice modem
isdn guard-timer 3000
isdn supp-service name calling
isdn T310 30000
isdn disconnect-cause 1
isdn bchan-number-order descending
fair-queue 64 256 0
no cdp enable
!
interface FastEthernet0
ip address 10.1.1.2 255.255.255.0
no ip route-cache
no ip mroute-cache
duplex auto
speed auto
!
ip classless
ip route 0.0.0.0 0.0.0.0 172.18.193.1
ip route 0.0.0.0 0.0.0.0 172.18.193.129
ip route 0.0.0.0 0.0.0.0 172.18.207.129
ip route 0.0.0.0 0.0.0.0 172.18.16.129
ip route 0.0.0.0 0.0.0.0 Ethernet0
ip route 0.0.0.0 0.0.0.0 172.18.197.1
```

```
ip route 0.0.0.0 255.255.255.0 Ethernet0
ip route 10.2.0.1 255.255.255.255 172.18.16.135
ip route 172.18.0.0 255.255.0.0 Ethernet0
no ip http server
!
map-class dialer test
  dialer voice-call
dialer-list 1 protocol ip permit
!
control-plane
!
voice-port 0:D
!
dial-peer voice 10 pots
  application session.t.old
  destination-pattern 5550100
  prefix 5550100
!
dial-peer voice 4 voip
  application session
  destination-pattern 5550120
  session protocol sipv2
  session target ipv4:172.18.193.99
  incoming called-number 5550125
!
dial-peer voice 1 pots
  application session
  destination-pattern 5550125
  incoming called-number 5550155
  port 0:D
  prefix 95550125
!
dial-peer voice 18 voip
  application session
  destination-pattern 36601
  session protocol sipv2
  session target ipv4:172.18.193.187
  codec g711ulaw
!
dial-peer voice 25 voip
  destination-pattern 5550155
  session protocol sipv2
  session target ipv4:172.18.192.232
!
dial-peer voice 5678 pots
  destination-pattern 5678
  port 3:D
  prefix 5678
!
dial-peer voice 56781 voip
  incoming called-number 5678
!
sip-ua
!
line con 0
line aux 0
line vty 0 4
  password password1
  login
!
end
```

## Signal ISDN B-Channel ID to Enable Application Control of Voice Gateway Trunks: Example

```
Router# show running-config

Building configuration...

Current configuration : 3394 bytes
!
version 12.3
service timestamps debug uptime
service timestamps log uptime
no service password-encryption
service internal
!
memory-size iomem 15
ip subnet-zero
!
no ip domain lookup
!
voice service voip
  h323
    billing b-channel
  sip
    ds0-num

ip dhcp pool vespa
  network 192.168.0.0 255.255.255.0
  option 150 ip 192.168.0.1
  default-router 192.168.0.1
!
voice call carrier capacity active
!
voice class codec 1
  codec preference 2 g711ulaw
!
no voice hpi capture buffer
no voice hpi capture destination
!
fax interface-type fax-mail
mta receive maximum-recipients 0
!
interface Ethernet0/0
  ip address 10.8.17.22 255.255.0.0
  half-duplex
!
interface FastEthernet0/0
  ip address 192.168.0.1 255.255.255.0
  speed auto
  no cdp enable
  h323-gateway voip interface
  h323-gateway voip id vespa2 ipaddr 10.8.15.4 1718
!
router rip
  network 10.0.0.0
  network 192.168.0.0
!
ip default-gateway 10.8.0.1
ip classless
ip route 0.0.0.0 0.0.0.0 10.8.0.1
no ip http server
ip pim bidir-enable
```

```

!
tftp-server flash:SEPDEFAULT.cnf
tftp-server flash:P005B302.bin
call fallback active
!
call application global default.new
call rsvp-sync
!
voice-port 1/0
!
voice-port 1/1
!
mgcp profile default
!
dial-peer voice 1 pots
 destination-pattern 5100
 port 1/0
!
dial-peer voice 2 pots
 destination-pattern 9998
 port 1/1
!
dial-peer voice 123 voip
 destination-pattern [12]...
 session protocol sipv2
 session target ipv4:10.8.17.42
 dtmf-relay sip-notify
!
gateway
!
sip-ua
 retry invite 3
 retry register 3
 timers register 150
 registrar dns:myhost3.example.com expires 3600
 registrar ipv4:10.8.17.40 expires 3600 secondary
!
telephony-service
 max-dn 10
 max-conferences 4
!
ephone-dn 1
 number 4001
!
ephone-dn 2
 number 4002
!
line con 0
 exec-timeout 0 0
line aux 0
line vty 0 4
 login
line vty 5 15
 login
!
no scheduler allocate
end

```

## SIP Carrier Identification Code: Examples

This section provides the following configuration examples:

- [CIC Parameter in SIP URL, page 37](#)
- [CIC Parameter in TEL URL, page 37](#)
- [CIC Parameter and Visual Separators, page 37](#)
- [Copying the CIC Parameter into the Resulting INVITE Request, page 37](#)

### CIC Parameter in SIP URL

This configuration example shows support for the CIC parameter in the user information part of the SIP URL. A SIP URL identifies a user's address and appears similar to an e-mail address, such as *user@host*, where *user* is the telephone number and *host* is either a domain name or a numeric network address. For example, the request line of an outgoing INVITE request might appear as:

```
INVITE sip:+5550100;cic=+16789@example.com;user=phone SIP/2.0
```

Where *+5550100*; *cic=+16789* signifies the user information, *example.com* the domain name, and the *user=phone* parameter distinguishes that the user address is a telephone number rather than a username.

### CIC Parameter in TEL URL

This configuration example shows support for the CIC parameter in the telephone-subscriber part of the TEL URL. A TEL URL takes the basic form of *tel:telephone subscriber number*, where *tel* requests the local entity to place a voice call, and *telephone subscriber number* is the number to receive the call. For example:

```
tel:+5550100;cic=+16789
```

The additional CIC parameter can be in any of the following three formats:

```
cic=+16789  
cic=+1-6789  
cic=6789
```

### CIC Parameter and Visual Separators

This configuration example shows support for the CIC parameter in different formats —with and without visual separators. However, the CIC parameter usually has no visual separators. All of the following formats are accepted:

```
+12345  
cic=+12345  
cic=2345
```

### Copying the CIC Parameter into the Resulting INVITE Request

This configuration example shows that the CIC parameter can be copied from the user information part of a 3xx Contact SIP URL into the resulting INVITE request.

For example, if a 302 REDIRECT response from a proxy appears like:

```
Contact: <sip:+5550100;cic=+16789@example.com;user=phone>
```

or like:

```
Contact: <sip:+5550100;cic=6789@example.com;user=phone>
```

The result is an INVITE request that sends the CIC with a +1 prefixed to it.

```
INVITE sip:+5550100;cic=+16789@example.com;user=phone SIP/2.0
```

## SIP: CLI for Caller ID When Privacy Exists: Examples

The following shows an example of the SIP: CLI for Caller ID When Privacy Exists feature when enabled globally and disabled on the dial-peer level:

```
Router# show running-config

Building configuration...
Current configuration: 1234 bytes
!
version 12.4
service timestamps debug datetime msec localtime
service timestamps log datetime msec localtime
no service password-encryption
!
hostname pip
!
boot-start-marker
boot system tftp user1/c3660-is-mz 172.18.207.15
boot-end-marker
!
logging buffered 1000000 debugging
enable secret 5 $1$li0u$IkIqPXzKq4uKme.LhzGut0
enable password password1
!
no aaa new-model
!
resource policy
!
clock timezone GMT 0
clock summer-time EDT recurring
ip subnet-zero
ip tcp path-mtu-discovery
!
ip cef
ip domain name example.sip.com
ip host sip-server1 172.18.193.100
ip host CALLGEN-SECURITY-V2 10.76.47.38 10.30.0.0
ip name-server 172.18.192.48
no ip dhcp use vrf connected
!
ip vrf btknet
rd 8262:2000
!
voice call send-alert
!
voice service voip <- SIP: CLI for Caller ID When Privacy Exists feature enabled globally
clid substitute name
clid strip pi-restrict all
clid network-provided
sip
!
voice class codec 1
codec preference 1 g729r8
codec preference 2 g711alaw
codec preference 3 g711ulaw
codec preference 4 g729br8
codec preference 5 g726r32
codec preference 6 g726r24
codec preference 7 g726r16
codec preference 8 g723ar53
codec preference 9 g723r53
codec preference 10 g723ar63
```

```
codec preference 11 gsmefr
codec preference 12 gsmfr
codec preference 13 g728
!
voice class codec 2
codec preference 1 g729r8
codec preference 2 g711ulaw
codec preference 3 g711alaw
!
voice class codec 99
codec preference 1 g729r8
codec preference 2 g711ulaw
codec preference 3 g711alaw
!
fax interface-type fax-mail
!
interface FastEthernet0/0
ip address 172.18.195.49 255.255.255.0
duplex auto
speed auto
no cdp enable
ip rsvp bandwidth 96 96
!
interface FastEthernet0/1
ip address 172.18.193.190 255.255.255.0
shutdown
duplex auto
speed auto
no cdp enable
!
no ip http server
!
ip classless
ip route 0.0.0.0 0.0.0.0 FastEthernet0/0
ip route 172.16.0.0 255.0.0.0 172.18.195.1
!
snmp-server community public RO
!
control-plane
!
voice-port 1/0/0
!
voice-port 1/0/1
!
mgcp behavior rsip-range tgcp-only
!
dial-peer cor custom
!
dial-peer voice 100 pots
destination-pattern 9001
!
dial-peer voice 3301 voip
destination-pattern 9002
session protocol sipv2
session target ipv4:172.18.193.87
incoming called-number 9001
codec g711ulaw
no vad
!
dial-peer voice 3303 voip
destination-pattern 777
session protocol sipv2
session target ipv4:172.18.199.94
!
```

```

dial-peer voice 36601 voip
destination-pattern 36601
no modem passthrough
session protocol sipv2
session target ipv4:172.18.193.98
!
dial-peer voice 5 voip
destination-pattern 5550100
session protocol sipv2
session target ipv4:172.18.197.182
codec g711ulaw
!
dial-peer voice 36602 voip
destination-pattern 36602
session protocol sipv2
session target ipv4:172.18.193.120
incoming called-number 9001
dtmf-relay rtp-nte
codec g711ulaw
!
dial-peer voice 111 voip
destination-pattern 111
session protocol sipv2
session target ipv4:172.18.193.251
!
dial-peer voice 5550199 voip <- SIP: CLI for Caller ID When Privacy Exists feature
disabled on dial-peer
destination-pattern 3100801
session protocol sipv2
session target ipv4:10.102.17.208
codec g711ulaw
!
dial-peer voice 333 voip
preference 2
destination-pattern 333
modem passthrough nse codec g711ulaw
voice-class codec 99
session protocol sipv2
session target ipv4:172.18.193.250
dtmf-relay rtp-nte
no vad
!
dial-peer voice 9003 pots
preference 2
destination-pattern 9003
!
dial-peer voice 90032 voip
preference 1
destination-pattern 9003
session protocol sipv2
session target ipv4:172.18.193.97
!
dial-peer voice 1 pots
!
num-exp 5550100 5550199
num-exp 5550199 5550100
gateway
timer receive-rtp 1200
!
sip-ua
srv version 1
retry response 1
!
line con 0

```

```

exec-timeout 0 0
line aux 0
line vty 0 4
exec-timeout 0 0
password password1
login
!
no process cpu extended
no process cpu autoprofile hog
ntp clock-period 17180176
ntp server 192.0.10.150 prefer
!
end

```

The following shows an example of the SIP: CLI for Caller ID When Privacy Exists feature when disabled globally and disabled on the dial-peer level:

Router# **show running-config**

```

Building configuration...
Current configuration: 1234 bytes
!
service timestamps debug datetime msec localtime
service timestamps log datetime msec localtime
no service password-encryption
!
hostname pip
!
boot-start-marker
boot system tftp user1/c3660-is-mz 172.18.207.15
boot-end-marker
!
logging buffered 1000000 debugging
enable secret 5 $1$li0u$IkiqPXzKq4uKme.LhzGut0
enable password password1
!
no aaa new-model
!
resource policy
!
clock timezone GMT 0
clock summer-time EDT recurring
ip subnet-zero
ip tcp path-mtu-discovery
!
ip cef
ip domain name example.sip.com
ip host sip-server1 172.18.193.100
ip host CALLGEN-SECURITY-V2 10.76.47.38 10.30.0.0
ip name-server 172.18.192.48
no ip dhcp use vrf connected
!
ip vrf btknet
rd 8262:2000
!
voice call send-alert
!
voice service voip <- SIP: CLI for Caller ID When Privacy Exists feature disabled globally
sip
!
voice class codec 1
codec preference 1 g729r8
codec preference 2 g711alaw
codec preference 3 g711ulaw

```

```
codec preference 4 g729br8
codec preference 5 g726r32
codec preference 6 g726r24
codec preference 7 g726r16
codec preference 8 g723ar53
codec preference 9 g723r53
codec preference 10 g723ar63
codec preference 11 gsmefr
codec preference 12 gsmfr
codec preference 13 g728
!
voice class codec 2
codec preference 1 g729r8
codec preference 2 g711ulaw
codec preference 3 g711alaw
!
voice class codec 99
codec preference 1 g729r8
codec preference 2 g711ulaw
codec preference 3 g711alaw
!
fax interface-type fax-mail
!
interface FastEthernet0/0
ip address 172.18.195.49 255.255.255.0
duplex auto
speed auto
no cdp enable
ip rsvp bandwidth 96 96
!
interface FastEthernet0/1
ip address 172.18.193.190 255.255.255.0
shutdown
duplex auto
speed auto
no cdp enable
!
no ip http server
!
ip classless
ip route 0.0.0.0 0.0.0.0 FastEthernet0/0
ip route 172.16.0.0 255.0.0.0 172.18.195.1
!
snmp-server community public RO
!
control-plane
!
voice-port 1/0/0
!
voice-port 1/0/1
!
mgcp behavior rsip-range tgcp-only
!
dial-peer cor custom
!
dial-peer voice 100 pots
destination-pattern 9001
!
dial-peer voice 3301 voip
destination-pattern 9002
session protocol sipv2
session target ipv4:172.18.193.87
incoming called-number 9001
codec g711ulaw
```

```

no vad
!
dial-peer voice 3303 voip
destination-pattern 777
session protocol sipv2
session target ipv4:172.18.199.94
!
dial-peer voice 36601 voip
destination-pattern 36601
no modem passthrough
session protocol sipv2
session target ipv4:172.18.193.98
!
dial-peer voice 5 voip
destination-pattern 5550100
session protocol sipv2
session target ipv4:172.18.197.182
codec g711ulaw
!
dial-peer voice 36602 voip
destination-pattern 36602
session protocol sipv2
session target ipv4:172.18.193.120
incoming called-number 9001
dtmf-relay rtp-nte
codec g711ulaw
!
dial-peer voice 111 voip
destination-pattern 111
session protocol sipv2
session target ipv4:172.18.193.251
!
dial-peer voice 5550199 voip <- SIP: CLI for Caller ID When Privacy Exists feature
disabled on dial-peer
destination-pattern 5550199
session protocol sipv2
session target ipv4:10.102.17.208
codec g711ulaw
!
dial-peer voice 333 voip
preference 2
destination-pattern 333
modem passthrough nse codec g711ulaw
voice-class codec 99
session protocol sipv2
session target ipv4:172.18.193.250
dtmf-relay rtp-nte
no vad
!
dial-peer voice 9003 pots
preference 2
destination-pattern 9003
!
dial-peer voice 90032 voip
preference 1
destination-pattern 9003
session protocol sipv2
session target ipv4:172.18.193.97
!
dial-peer voice 1 pots
!
num-exp 5550100 5550199
num-exp 5550101 5550198
gateway

```

```

timer receive-rtp 1200
!
sip-ua
  srv version 1
  retry response 1
!
!
line con 0
exec-timeout 0 0
line aux 0
line vty 0 4
exec-timeout 0 0
password password1
login
!
no process cpu extended
no process cpu autopfile hog
ntp clock-period 17180176
ntp server 192.0.10.150 prefer
!
end

```

The following shows an example of the SIP: CLI for Caller ID When Privacy Exists feature when disabled globally and enabled on the dial-peer level:

```
Router# show running-config
```

```

Building configuration...
Current configuration: 1234 bytes
!
version 12.4
service timestamps debug datetime msec localtime
service timestamps log datetime msec localtime
no service password-encryption
!
hostname pip
!
boot-start-marker
boot system tftp judyg/c3660-is-mz 172.18.207.15
boot-end-marker
!
logging buffered 1000000 debugging
enable secret 5 $1$li0u$IkIqPXzKq4uKme.LhzGut0
enable password password1
!
no aaa new-model
!
resource policy
!
clock timezone GMT 0
clock summer-time EDT recurring
ip subnet-zero
ip tcp path-mtu-discovery
!
ip cef
ip domain name example.sip.com
ip host sip-server1 172.18.193.100
ip host CALGEN-SECURITY-V2 10.76.47.38 10.30.0.0
ip name-server 172.18.192.48
no ip dhcp use vrf connected
!
ip vrf btknet
rd 8262:2000
!

```

```
voice call send-alert
!
voice service voip <- SIP: CLI for Caller ID When Privacy Exists feature disabled
globally
sip
!
voice class codec 1
codec preference 1 g729r8
codec preference 2 g711alaw
codec preference 3 g711ulaw
codec preference 4 g729br8
codec preference 5 g726r32
codec preference 6 g726r24
codec preference 7 g726r16
codec preference 8 g723ar53
codec preference 9 g723r53
codec preference 10 g723ar63
codec preference 11 gsmfr
codec preference 12 gsmfr
codec preference 13 g728
!
voice class codec 2
codec preference 1 g729r8
codec preference 2 g711ulaw
codec preference 3 g711alaw
!
voice class codec 99
codec preference 1 g729r8
codec preference 2 g711ulaw
codec preference 3 g711alaw
!
fax interface-type fax-mail
!
interface FastEthernet0/0
ip address 172.18.195.49 255.255.255.0
duplex auto
speed auto
no cdp enable
ip rsvp bandwidth 96 96
!
interface FastEthernet0/1
ip address 172.18.193.190 255.255.255.0
shutdown
duplex auto
speed auto
no cdp enable
!
no ip http server
!
ip classless
ip route 0.0.0.0 0.0.0.0 FastEthernet0/0
ip route 172.16.0.0 255.0.0.0 172.18.195.1
!
snmp-server community public RO
!
control-plane
!
voice-port 1/0/0
!
voice-port 1/0/1
!
mgcp behavior rsip-range tgcp-only
!
dial-peer cor custom
```

```

!
dial-peer voice 100 pots
destination-pattern 9001
!
dial-peer voice 3301 voip
destination-pattern 9002
session protocol sipv2
session target ipv4:172.18.193.87
incoming called-number 9001
codec g711ulaw
no vad
!
dial-peer voice 3303 voip
destination-pattern 777
session protocol sipv2
session target ipv4:172.18.199.94
!
dial-peer voice 36601 voip
destination-pattern 36601
no modem passthrough
session protocol sipv2
session target ipv4:172.18.193.98
!
dial-peer voice 5 voip
destination-pattern 5550102
session protocol sipv2
session target ipv4:172.18.197.182
codec g711ulaw
!
dial-peer voice 36602 voip
destination-pattern 36602
session protocol sipv2
session target ipv4:172.18.193.120
incoming called-number 9001
dtmf-relay rtp-nte
codec g711ulaw
!
dial-peer voice 111 voip
destination-pattern 111
session protocol sipv2
session target ipv4:172.18.193.251
!
dial-peer voice 5550100 voip <- SIP: CLI for Caller ID When Privacy Exists feature enabled
on dial-peer
destination-pattern 5550100
session protocol sipv2
session target ipv4:10.102.17.208
codec g711ulaw
clid strip pi-restrict all
clid network-provided
clid substitute name
!
dial-peer voice 333 voip
preference 2
destination-pattern 333
modem passthrough nse codec g711ulaw
voice-class codec 99
session protocol sipv2
session target ipv4:172.18.193.250
dtmf-relay rtp-nte
no vad
!
dial-peer voice 9003 pots
preference 2

```

```

destination-pattern 9003
!
dial-peer voice 90032 voip
preference 1
destination-pattern 9003
session protocol sipv2
session target ipv4:172.18.193.97
!
dial-peer voice 1 pots
!
num-exp 5550100 5550199
num-exp 5550101 5550198
gateway
timer receive-rtp 1200
!
sip-ua
srv version 1
retry response 1
!
!
line con 0
exec-timeout 0 0
line aux 0
line vty 0 4
exec-timeout 0 0
password password1
login
!
no process cpu extended
no process cpu autopprofile hog
ntp clock-period 17180176
ntp server 192.0.10.150 prefer
!
end

```

## SIP: ISDN Suspend/Resume Support: Example

The following example shows SIP Suspend and Resume disabled on the gateway (SIP Suspend and Resume is enabled by default on the gateway).



### Note

---

IP addresses and hostnames in examples are fictitious.

---

```

Router# show running-config

Building configuration...

Current configuration : 3845 bytes
!
version 12.3
service timestamps debug datetime msec
service timestamps log uptime
no service password-encryption
!
boot-start-marker
boot-end-marker
!
no logging buffered
!
resource-pool disable

```

```

clock timezone GMT 5
clock summer-time GMT recurring
!

no aaa new-model
ip subnet-zero
ip tcp path-mtu-discovery
ip name-server 172.18.192.48
!
isdn switch-type primary-ni
isdn voice-call-failure 0
isdn alert-end-to-end
!
voice call send-alert
!
voice service voip
  signaling forward unconditional
  sip
!
fax interface-type fax-mail
!
controller T1 0
  framing esf
  crc-threshold 0
  clock source line primary
  linecode b8zs
  pri-group timeslots 1-24
  description lucent_pbx
!
controller T1 1
  shutdown
  framing esf
  crc-threshold 0
  linecode ami
  description summa_pbx
!
controller T1 2
  shutdown
  framing esf
  crc-threshold 0
  linecode ami
!
controller T1 3
  framing esf
  crc-threshold 0
  clock source line secondary 1
  linecode b8zs
  pri-group timeslots 1-24
!
translation-rule 100
  Rule 1 ^1 1 ANY national
  Rule 2 2% 2 ANY unknown
  Rule 4 4% 4 ANY unknown
  Rule 5 5% 5 ANY unknown
  Rule 6 6% 6 ANY unknown
  Rule 7 7% 7 ANY unknown
  Rule 8 8% 8 ANY unknown
  Rule 9 9% 9 ANY unknown
!
interface Ethernet0
  ip address 172.18.193.100 255.255.255.0
  no ip route-cache
  no ip mroute-cache

```

```

ip rsvp bandwidth 1 1
!
interface Serial0:23
no ip address
isdn switch-type primary-ni
isdn incoming-voice modem
isdn guard-timer 3000
isdn supp-service name calling
isdn disconnect-cause 1
fair-queue 64 256 0
no cdp enable
!
interface Serial13:23
no ip address
isdn switch-type primary-ni
isdn protocol-emulate network
isdn incoming-voice modem
isdn guard-timer 3000
isdn supp-service name calling
isdn T310 30000
isdn disconnect-cause 1
isdn bchan-number-order descending
fair-queue 64 256 0
no cdp enable
!
interface FastEthernet0
ip address 10.1.1.2 255.255.255.0
no ip route-cache
no ip mroute-cache
duplex auto
speed auto
!
ip classless
ip route 0.0.0.0 0.0.0.0 172.18.193.1
ip route 0.0.0.0 0.0.0.0 172.18.193.129
ip route 0.0.0.0 0.0.0.0 172.18.207.129
ip route 0.0.0.0 0.0.0.0 172.18.16.129
ip route 0.0.0.0 0.0.0.0 Ethernet0
ip route 0.0.0.0 0.0.0.0 172.18.197.1
ip route 0.0.0.0 255.255.255.0 Ethernet0
ip route 10.2.0.1 255.255.255.255 172.18.16.135
ip route 172.18.0.0 255.255.0.0 Ethernet0
no ip http server
!
map-class dialer test
dialer voice-call
dialer-list 1 protocol ip permit
!
control-plane
!
voice-port 0:D
!
dial-peer voice 10 pots
application session.t.old
destination-pattern 5550100
prefix 5550100
!
dial-peer voice 4 voip
application session
destination-pattern 5550120
session protocol sipv2
session target ipv4:172.18.193.99
incoming called-number 5550125
!

```

```

dial-peer voice 1 pots
  application session
  destination-pattern 5550125
  incoming called-number 5550155
  port 0:D
  prefix 95550125
!
dial-peer voice 18 voip
  application session
  destination-pattern 36601
  session protocol sipv2
  session target ipv4:172.18.193.187
  codec g711ulaw
!
dial-peer voice 25 voip
  destination-pattern 5550155
  session protocol sipv2
  session target ipv4:172.18.192.232
!
dial-peer voice 5678 pots
  destination-pattern 5678
  port 3:D
  prefix 5678
!
dial-peer voice 56781 voip
  incoming called-number 5678
!
sip-ua
  no suspend-resume
  retry invite 1
  retry bye 1

line con 0
line aux 0
line vty 0 4
  password password1
  login
!
end

```

## SIP PSTN Transport Using the Cisco Generic Transparency Descriptor: Examples

### Configuring GTD Globally

The following examples shows that GTD is configured.

```
Router# show running-config
```

```
Building configuration...
```

```

Current configuration : 4192 bytes
!
version 12.2
service config
no service single-slot-reload-enable
no service pad
service timestamps debug uptime
service timestamps log uptime
no service password-encryption
service internal

```

```
service udp-small-servers
!
hostname router
!
voice service voip
  signaling forward unconditional
  sip
.
```

### Configuring GTD for an Individual Dial Peer

The following example shows GTD configured with unconditional forwarding on two dial peers:

```
Router# show running-config

Building configuration...

Current configuration : 4169 bytes
!
version 12.2
service config
no service single-slot-reload-enable
no service pad
service timestamps debug uptime
service timestamps log uptime
no service password-encryption
service internal
service udp-small-servers
!
hostname router
.
.
.
dial-peer voice 36 voip
  incoming called-number 3100802
  destination-pattern 3100801
  signaling forward unconditional
  session protocol sipv2
  session target ipv4:192.0.2.209
!
dial-peer voice 5 voip
  destination-pattern 5555555
  signaling forward unconditional
  session protocol sipv2
  session target ipv4:172.18.192.218
.
.
.
```

## Additional References

### General SIP References

- [“SIP Features Roadmap” on page 1](#)—Describes how to access Cisco Feature Navigator; also lists and describes, by Cisco IOS release, SIP features for that release.
- [“Basic SIP Configuration” on page 1](#)—Describes underlying SIP technology; also lists related documents, standards, MIBs, RFCs, and how to obtain technical assistance.

**References Mentioned in This Chapter (listed alphabetically)**

- *Configuring H.323 Gateways* at [http://www.cisco.com/univercd/cc/td/doc/product/software/ios123/123cgr/vvfax\\_c/callc\\_c/h323\\_c/323confg/3gwconf.htm](http://www.cisco.com/univercd/cc/td/doc/product/software/ios123/123cgr/vvfax_c/callc_c/h323_c/323confg/3gwconf.htm)
- *Redundant Link Manager (RLM)* at [http://www.cisco.com/univercd/cc/td/doc/product/access/acs\\_serv/as5400/sw\\_conf/ios\\_121/pull\\_rm.htm](http://www.cisco.com/univercd/cc/td/doc/product/access/acs_serv/as5400/sw_conf/ios_121/pull_rm.htm)

---

CCVP, the Cisco logo, and Welcome to the Human Network are trademarks of Cisco Systems, Inc.; Changing the Way We Work, Live, Play, and Learn is a service mark of Cisco Systems, Inc.; and Access Registrar, Aironet, Catalyst, CCDA, CCDP, CCIE, CCIP, CCNA, CCNP, CCSP, Cisco, the Cisco Certified Internetwork Expert logo, Cisco IOS, Cisco Press, Cisco Systems, Cisco Systems Capital, the Cisco Systems logo, Cisco Unity, Enterprise/Solver, EtherChannel, EtherFast, EtherSwitch, Fast Step, Follow Me Browsing, FormShare, GigaDrive, HomeLink, Internet Quotient, IOS, iPhone, IP/TV, iQ Expertise, the iQ logo, iQ Net Readiness Scorecard, iQuick Study, LightStream, Linksys, MeetingPlace, MGX, Networkers, Networking Academy, Network Registrar, PIX, ProConnect, ScriptShare, SMARTnet, StackWise, The Fastest Way to Increase Your Internet Quotient, and TransPath are registered trademarks of Cisco Systems, Inc. and/or its affiliates in the United States and certain other countries.

All other trademarks mentioned in this document or Website are the property of their respective owners. The use of the word partner does not imply a partnership relationship between Cisco and any other company. (0711R)

Any Internet Protocol (IP) addresses used in this document are not intended to be actual addresses. Any examples, command display output, and figures included in the document are shown for illustrative purposes only. Any use of actual IP addresses in illustrative content is unintentional and coincidental.

© 2007 Cisco Systems, Inc. All rights reserved.