



Configuring SIP Support for Hookflash

This chapter contains information about the SIP Support for Hookflash feature that allows you to configure IP Centrex supplementary services on SIP-enabled, Foreign Exchange Station (FXS) lines. Supplementary services for the SIP Support for Hookflash feature include the following:

- Call hold
- Call waiting
- Call transfer
- 3-Way conferencing

Use the **service dsapp** command to configure supplementary Centrex-like features on FXS phones to interwork with SIP-based softswitches. The SIP Support for Hookflash feature supports the concept of a dual-line (ACTIVE and STANDBY for active and held calls) for FXS calls to support supplementary services. Hookflash triggers supplementary services based on the current state of the call.

You can configure the **service dsapp** command on individual dial peers, or configure globally for all calls entering the gateway.

Feature History for SIP Support for Hookflash

Release	Modification
12.4(11)T	This feature was introduced.

Contents

- [Prerequisites for SIP Support for Hookflash, page 2](#)
- [Information About SIP Support for Hookflash, page 2](#)
- [How to Configure and Associate SIP Support for Hookflash, page 11](#)
- [Configuration Examples for SIP Support for Hookflash, page 20](#)
- [Additional References, page 24](#)



Americas Headquarters:
Cisco Systems, Inc., 170 West Tasman Drive, San Jose, CA 95134-1706 USA

© 2007 Cisco Systems, Inc. All rights reserved.

Prerequisites for SIP Support for Hookflash

All Hookflash Features for FXS Ports

- Ensure that the gateway has voice functionality that is configurable for SIP.
- Establish a working IP network. For information on configuring IP, see the [Cisco IOS IP Configuration Guide](#), Release 12.3.
- Configure VoIP.

Information About SIP Support for Hookflash

Use the **service dsapp** command to configure supplementary Centrex-like services on FXS phones to interwork with SIP-based softswitches. Hookflash triggers supplementary features based on the current state of the call and provides a simulation of dual-line capability for analog phones to allow one line to be active while the other line is used to control supplementary IP Centrex services. Supplementary services for the SIP Support for Hookflash feature include the following:

- [Call Hold, page 2](#)
- [Call Waiting, page 4](#)
- [Call Transfers, page 5](#)
- [3-Way Conference, page 9](#)

Call Hold

With the Call Hold feature, you can place a call on hold. When you are active with a call and you press hookflash, and there is no call that is waiting, you hear a dial tone.

If there is a call on hold, the hookflash switches between two calls; the call on hold becomes active while the active call is put on hold.

If you have a call on hold and the call hangs up, the call on hold is disconnected.

Call Holding Flows

The sequence of placing a call on hold is summarized in the following steps:

1. User A and user B are active with a call.
2. By pressing hookflash, user A initiates a call hold.
3. SIP sends a call hold indication to user B.
4. User A can now initiate another active call (user C), transfer the active call (call transfer), or respond to a call-waiting indication.



Note

Use the **offer call-hold** command in sip-ua configuration mode to configure the method of hold used on the gateway. For detailed information on the **offer call-hold** command, see the [Cisco IOS Voice Command Reference Guide](#).

5. User A receives a second dial tone and presses hookflash.

Figure 79 shows the initiation of the calls hold sequence.

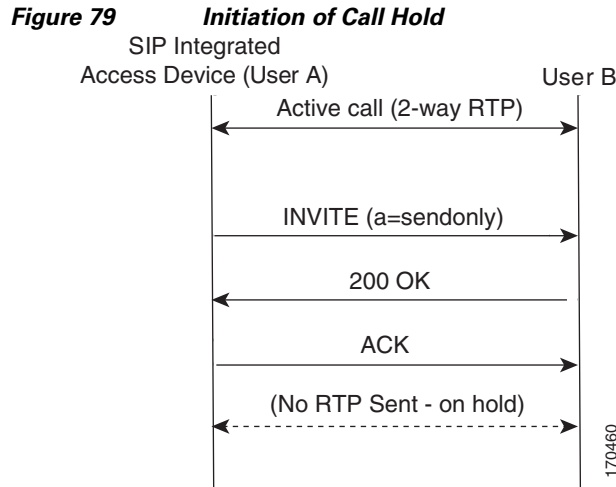

6. User A and User B reconnect.

Figure 80 shows the calls on hold resume sequence.

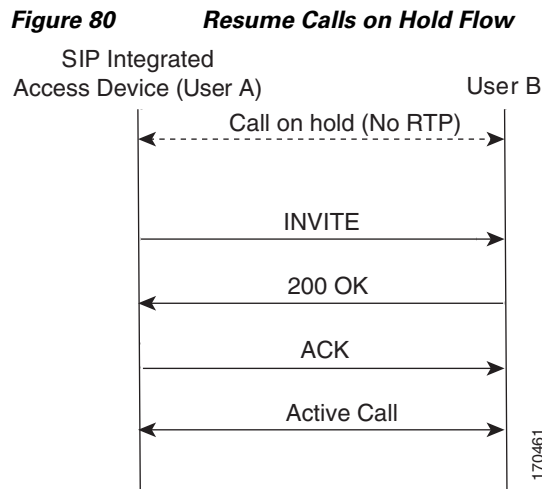

Table 48 summarizes the hookflash support for Call Hold services.

Table 48 Call Hold Hookflash Services

State	Action	Result	Response to FXS Line
Active call	Hookflash	Call placed on hold for remote party.	Second dial tone for FXS phone.
Call on hold	Hookflash	Active call.	FXS line connects to call.

Table 48 Call Hold Hookflash Services

State	Action	Result	Response to FXS Line
Call on hold and active call	Hookflash	Active and call on hold are swapped.	FXS line connects to previous held call.
	On hook	Active call is dropped.	Held call still active. Reminder ring on FXS line.
	Call on hold goes on hook	Call on hold is dropped.	None.
	Active call goes on hook	Active call is dropped.	Silence. Reconnects to held call after the value you specify for disc-toggle-time expires. See How to Configure Disconnect Toggle Time , page 16.

Call Waiting

With the Call Waiting feature, you can receive a second call while you are on the phone with another call. When you receive a second call, you hear a call-waiting tone (a tone with a 300 ms duration). Caller ID appears on phones that support caller ID. You can use hookflash to answer a waiting call and place the previously active call on hold. By using hookflash, you can toggle between the active and a call that is on hold. If the Call Waiting feature is disabled, and you hang up the current call, the second call will hear a busy tone.

The call-waiting sequence is summarized in the following steps:

1. User A is active with a call to user B
2. User C calls user B
3. User B presses hookflash.
The call between user A and user B is held.
4. User B connects to user C.

[Figure 81](#) shows the call waiting sequence.

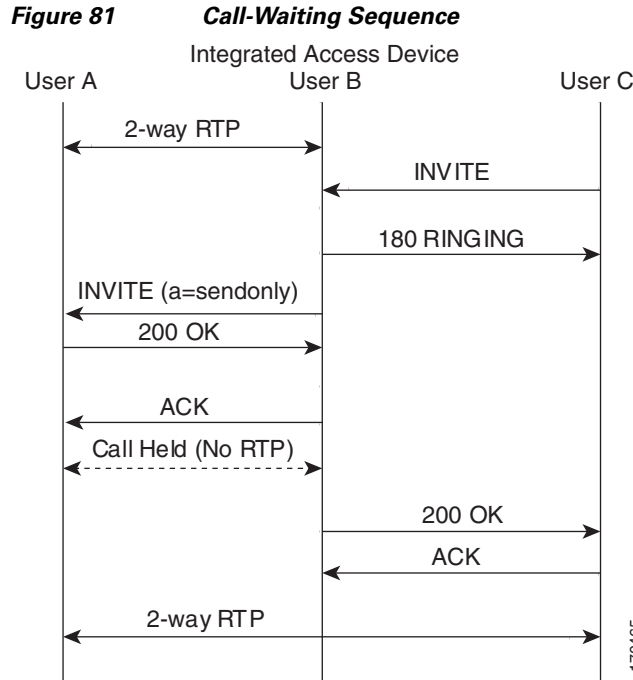

Table 49 summarizes hookflash support for Call Waiting services.

Table 49 Call Waiting Hookflash Services

State	Action	Result	Response to FXS Line
Active call and waiting call	Hookflash	Swap active call and waiting call.	FXS line connects to waiting call.
	Active call disconnects	Active call is disconnected.	Silence.
	Waiting call goes disconnects	Stay connected to active call.	None.
	Call disconnects	Active call is dropped.	Reminder ring on FXS line.

Call Transfers

Call transfers are when active calls are put on hold while a second call is established between two users. After you establish the second call and terminate the active call, the call on hold will hear a ringback. The Call Transfer feature supports all three types of call transfers—blind, semi-attended, and attended.

Blind Call Transfer

The following describes a typical Blind call-transfer scenario:

1. User A calls user B.

- If user C is not busy and answers, user A and user C connect.

Figure 83 shows the call details for a semi-attended transfer.

Figure 83 *Initiation of Semi-Attended Transfer*

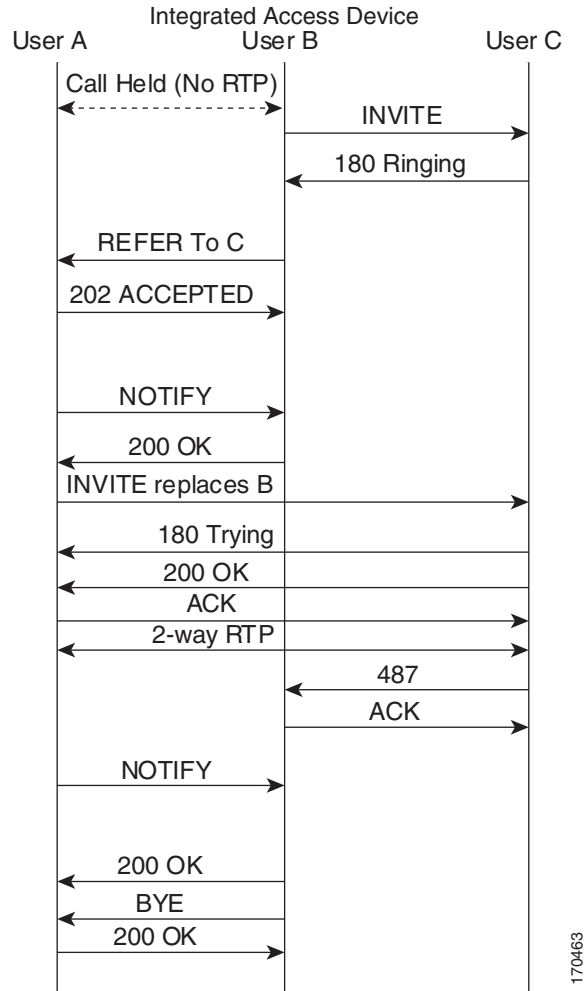

Attended Transfers

The following describes a typical attended transfer:

- User A calls user B.
- User B places user A on hold and dials user C.
- After user C answers, user B goes on-hook to initiate a transfer, and the call between user A and user B is terminated.
- User A is transferred to user C. If user C is busy when user B calls, user A hears a busy tone.
- If user C is not busy and answers, user A and user C connect.

Figure 84 shows the call details for an attended transfer.

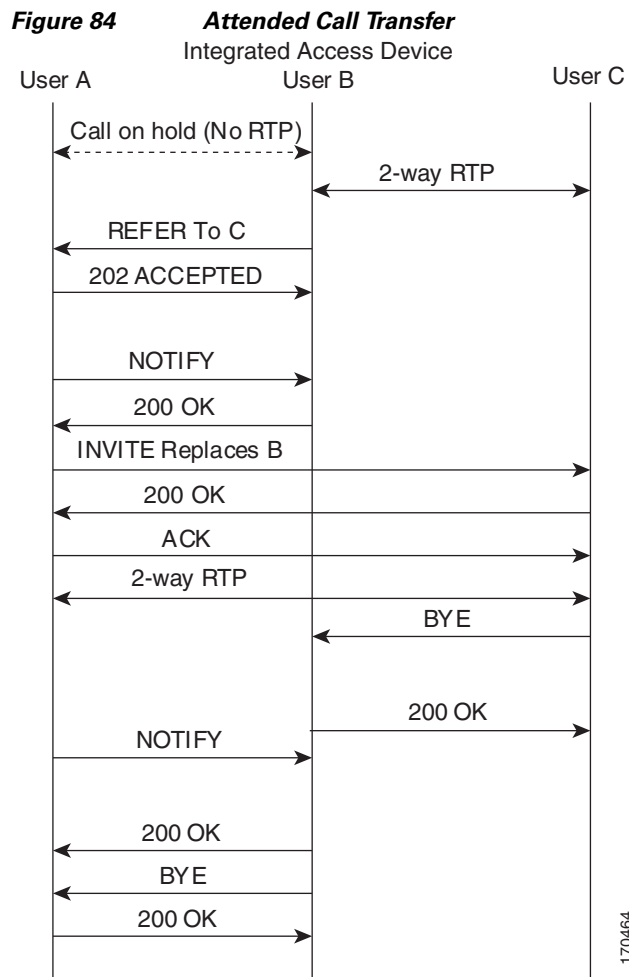

Table 50 summarizes the hookflash support for Call Transfer services.

Table 50 *Call Transfer Hook Flash Services*

State	Action	Result	Response to FXS Line
Active call	Hookflash.	Call placed on hold.	Second dial tone.
Call on hold and outgoing dialed or alerting, or active call	On hook.	Call on hold and active call transferred.	—
Call on hold and outgoing alerting call	Hookflash	Active call dropped.	FXS line connects to call on hold.

3-Way Conference

You can use the 3-Way Conference feature to establish two calls with a single connection so that all three parties can talk together. If the 3-Way Conference feature is disabled, a second hookflash will toggle between the two calls.



Note

The 3-Way Conference feature only supports those SIP calls using the g711 codex. This feature also supports specification GR-577-CORE.

Setting Up a 3-Way Conference

The following describes a typical 3-way conference scenario:

1. User A is talking with user B (a second-party call).
2. User A presses hookflash, receives a dial-tone, and dials user C.
3. User C answers. User A and user C are active in a second-party call.
4. User A presses hookflash to activate a 3-way conference.

In other terminology, user A is the host or controller; user B is the original call, and user C is the add-on.



Note

The 3-Way Conference feature is available when the second-party call is outgoing. If the second-party call is incoming and you press hookflash, the phone toggles between the two calls.

Figure 85 shows the call details for 3-way conferencing.

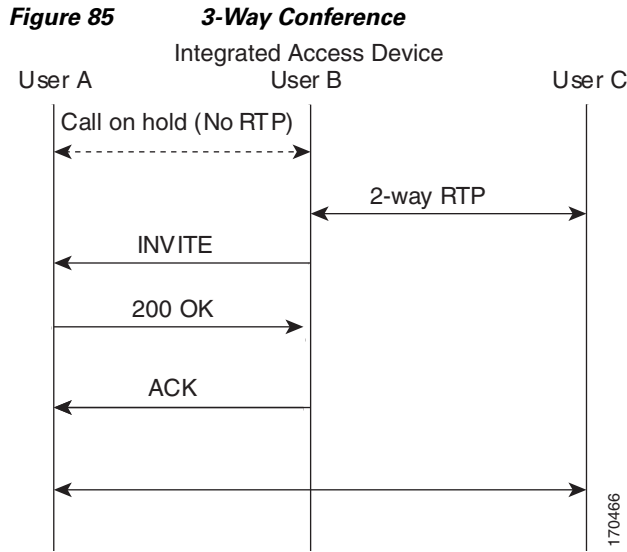

Table 51 summarizes the hookflash support for 3-way conferencing services.

Table 51 3-Way Conference Hookflash Services

State	Action	Result	Response to FXS Line
Active call	Hookflash	Call place on hold.	Second dial tone
Call on hold and active call		Join call on hold and active call.	Media mixing of both calls

Terminating a 3-Way Conference

Table 52 summarizes the termination of a 3-way conference:

Table 52 3-Way Conference Termination

State	Action	Result	Response to FXS Line
Active 3-way conference	User A disconnects first	3-Way conference terminates; all users are disconnected.	Dial tone
	User B disconnects first	User A and user C establish a second-party call.	FXS line connects user A and user C.
	User C disconnects first	User A and user B establish a second-party call.	FXS line connects user A and user B.
	User A presses hookflash	User C disconnects and user A and user B establish a second-party call.	FXS line connects user A and user B.

How to Configure and Associate SIP Support for Hookflash

This section describes the procedures for configuring and associating the SIP Support for Hookflash feature. These procedures include the following:

1. Configuring supplementary service by using the **service dsapp** command.
2. Associating the supplementary services with configured dial peers.

or

Associating the supplementary services as the global default application on a gateway.

This section provides configurations for the following supplementary services and provides configuration for associating supplementary services with dial peers:

- [How to Configure Call Hold, page 11](#)
- [How to Configure Call Waiting, page 13](#)
- [How to Configure Call Transfer, page 14](#)
- [How to Configure 3-Way Conferencing, page 15](#)
- [How to Configure Disconnect Toggle Time, page 16](#)
- [How to Configure Blind Transfer Wait Time, page 17](#)
- [How to Associate Services with a Fixed Dial Peer, page 18](#)
- [How to Associate Services Globally on a Gateway, page 19](#)

How to Configure Call Hold

To configure the Call Hold feature, follow these steps:

SUMMARY STEPS

1. **enable**
2. **configure terminal**
3. application
4. service dsapp
5. param callHold
6. exit

DETAILED STEPS

	Command or Action	Purpose
Step 1	enable Example: Router> enable	Enables privileged EXEC mode. <ul style="list-style-type: none">• Enter your password if prompted.
Step 2	configure terminal Example: Router# configure terminal	Enters global configuration mode.
Step 3	application Example: Router(config)# application	Enters SIP gateway-application configuration mode.
Step 4	service dsapp Example: Router(config-app)# service dsapp	Enters DSAPP parameters mode.
Step 5	param callHold TRUE Example: Router(config-app-param)# param callHold TRUE	Enables call hold.
Step 6	exit Example: Router (config-app-param)# exit	Exits the current mode.

How to Configure Call Waiting

To enable call waiting for a DSAPP, follow these steps:

SUMMARY STEPS

1. **enable**
2. **configure terminal**
3. **application**
4. **service dsapp**
5. **param callWaiting**
6. **exit**

DETAILED STEPS

	Command or Action	Purpose
Step 1	enable Example: Router> enable	Enables privileged EXEC mode. <ul style="list-style-type: none">• Enter your password if prompted.
Step 2	configure terminal Example: Router# configure terminal	Enters global configuration mode.
Step 3	application Example: Router(config)# application	Enters SIP gateway-application configuration mode.
Step 4	service dsapp Example: Router(config-app)# service dsapp	Enters DSAPP parameters mode.
Step 5	param callWaiting TRUE Example: Router(config-app-param)# param callWaiting TRUE	Enables call waiting.
Step 6	exit Example: Router (config-app-param)# exit	Exits the current mode.

How to Configure Call Transfer

To configure call transfer, follow these steps:

SUMMARY STEPS

1. **enable**
2. **configure terminal**
3. **application**
4. **service dsapp**
5. **param callTransfer**
6. **exit**

DETAILED STEPS

	Command or Action	Purpose
Step 1	enable Example: Router> enable	Enables privileged EXEC mode. <ul style="list-style-type: none"> • Enter your password if prompted.
Step 2	configure terminal Example: Router# configure terminal	Enters global configuration mode.
Step 3	application Example: Router (config)# application	Enters SIP gateway-application configuration mode.
Step 4	service dsapp Example: Router(config-app)# service dsapp	Enters DSAPP parameters mode.
Step 5	param callTransfer TRUE Example: Router(config-app-param)# param callTransfer TRUE	Enables call transfer.
Step 6	exit Example: Router(config-app-param)# exit	Exits the current mode.

How to Configure 3-Way Conferencing

To configure 3-way conferencing, follow these steps:

SUMMARY STEPS

1. **enable**
2. **configure terminal**
3. **application**
4. **service dsapp**
5. **param callConference**
6. **exit**

DETAILED STEPS

	Command or Action	Purpose
Step 1	enable Example: Router> enable	Enables privileged EXEC mode. <ul style="list-style-type: none">• Enter your password if prompted.
Step 2	configure terminal Example: Router# configure terminal	Enters global configuration mode.
Step 3	application Example: Router (config)# application	Enters SIP gateway-application configuration mode.
Step 4	service dsapp Example: Router(config-app)# service dsapp	Enters DSAPP parameters mode.
Step 5	param callConference TRUE Example: Router(config-app-param)# param callConference TRUE	Enables 3-way conferencing.
Step 6	exit Example: Router(config-app-param)# exit	Exits the current mode.

How to Configure Disconnect Toggle Time

You can configure the time to wait before switching to a call on hold if an active call disconnects (commonly known as disconnect toggle time). You can configure a time-to-wait range between 10 (default) and 30 seconds.

To configure disconnect toggle time, proceed with the following steps:

SUMMARY STEPS

1. **enable**
2. **configure terminal**
3. **application**
4. **service dsapp**
5. **param disc-toggle-time**
6. **exit**

DETAILED STEPS

	Command or Action	Purpose
Step 1	enable Example: Router> enable	Enables privileged EXEC mode. <ul style="list-style-type: none">Enter your password if prompted.
Step 2	configure terminal Example: Router# configure terminal	Enters global configuration mode.
Step 3	application Example: Router (config)# application	Enters SIP gateway-application configuration mode.
Step 4	service dsapp Example: Router(config-app)# service dsapp	Enters DSAPP parameters mode.
Step 5	param disc-toggle-time 20 Example: Router(config-app-param)# param disc-toggle-time 20	Sets the time to wait before switching to a call on hold, if the active call disconnects (disconnect toggle time). You can specify a disconnect toggle time between 10 (default) and 30 seconds.
Step 6	exit Example: Router(config-app-param)# exit	Exits the current mode.

How to Configure Blind Transfer Wait Time

To configure the time the system waits before establishing a call, so that you can transfer a call by placing the phone on hook, proceed with the following steps.

**Note**

The transferrer will not hear alerting for the time you configure because the system delays the call in case blind transfer is initiated.

SUMMARY STEPS

1. **enable**
2. **configure terminal**
3. **application**
4. **service dsapp**
5. **param blind-xfer-wait-time**

6. `exit`

DETAILED STEPS

	Command or Action	Purpose
Step 1	<code>enable</code> Example: Router> <code>enable</code>	Enables privileged EXEC mode. <ul style="list-style-type: none"> Enter your password if prompted.
Step 2	<code>configure terminal</code> Example: Router# <code>configure terminal</code>	Enters global configuration mode.
Step 3	<code>application</code> Example: Router(config)# <code>application</code>	Enters SIP gateway-application configuration mode.
Step 4	<code>service dsapp</code> Example: Router(config-app)# <code>service dsapp</code>	Enters DSAPP parameters mode.
Step 5	<code>param blind-xfer-wait-time</code> Example: Router(config-app-param)# <code>param blind-xfer-wait-time 10</code>	Enables call waiting.
Step 6	<code>exit</code> Example: Router (config-app-param)# <code>exit</code>	Exits the current mode.

How to Associate Services with a Fixed Dial Peer

After you have enabled and customized your services on a gateway by using the **service dsapp** command, you must associate these services with configured dial peers. You can associate individual dial peers, or alternately, you can configure these services globally on the gateway (see [How to Associate Services Globally on a Gateway, page 19](#)). If you associate these services globally, all calls entering from the FXS line side and from the SIP trunk side invoke the **service dsapp** services.

To configure a fixed dial peer used by DSAPP to set up a call to the SIP server (trunk) side, proceed with the following steps:

SUMMARY STEPS

1. `enable`
2. `configure terminal`
3. `application`

4. `service dsapp`
5. `param dialpeer dialpeer tag`
6. `exit`

DETAILED STEPS

	Command or Action	Purpose
Step 1	<code>enable</code> Example: Router> <code>enable</code>	Enables privileged EXEC mode. <ul style="list-style-type: none"> • Enter your password if prompted.
Step 2	<code>configure terminal</code> Example: Router# <code>configure terminal</code>	Enters global configuration mode.
Step 3	<code>application</code> Example: Router(config)# <code>application</code>	Enters SIP gateway-application configuration mode.
Step 4	<code>service dsapp</code> Example: Router (config-app)# <code>service dsapp</code>	Enters DSAPP parameters mode.
Step 5	<code>param dialpeer <i>dialpeer tag</i></code> Router(config-app-param)# <code>param dialpeer 5000</code>	Configures a fixed dial peer used by DSAPP to set up a call to the SIP server (trunk) side, where <i>dial peer tag</i> is the tag of the dial peer used to place an outgoing call on the IP trunk side. The <i>dial peer tag</i> must be the same tag as the dial peer configured to the SIP server.
Step 6	<code>exit</code> Example: Router(config-app-param)# <code>exit</code>	Exits the current mode.

How to Associate Services Globally on a Gateway

After you have enabled and customized your services on a gateway by using the **service dsapp** command, you must associate these services with configured dial peers. You can associate individual dial peers (see [How to Associate Services with a Fixed Dial Peer, page 18](#)), or alternately, you can configure these services globally on the gateway. If you associate these services globally, all calls entering from the FXS line side and from the SIP trunk side will invoke the **service dsapp** services.

To associate services globally on a gateway, proceed with the following steps:

SUMMARY STEPS

1. `enable`
2. `configure terminal`

3. application
4. global
5. service default dsapp
6. exit

DETAILED STEPS

	Command or Action	Purpose
Step 1	enable Example: Router> enable	Enables privileged EXEC mode. <ul style="list-style-type: none"> • Enter your password if prompted.
Step 2	configure terminal Example: Router# configure terminal	Enters global configuration mode.
Step 3	application Example: Router(config)# application	Enters SIP gateway-application configuration mode.
Step 4	global Example: Router (config-app)# global	Enters SIP gateway-application-global configuration mode.
Step 5	service default dsapp Example: Router (config-app-global)# service default dsapp	Globally sets dsapp as the default application. All calls entering the gateway (from the FXS line side and the SIP trunk side) invoke the dsapp application.
Step 6	exit Example: Router(config-app-global)# exit	Exits the current mode.

Configuration Examples for SIP Support for Hookflash

This section contains the following configuration examples:

- [Configuring Call Hold: Example, page 21](#)
- [Configuring Call Waiting: Example, page 21](#)
- [Configuring Call Transfer: Example, page 21](#)
- [Configuring 3-Way Conferencing: Example, page 21](#)
- [Configuring Disconnect Toggle Time: Example, page 21](#)
- [Configuring Blind Transfer Wait Time: Example, page 22](#)

- [Configuring a Fixed Dial Peer Used for Outgoing Calls on SIP Trunk Side: Example, page 22](#)
- [Associating Services with a Fixed Dial Peer: Example, page 22](#)
- [Associating Services Globally on a Gateway: Example, page 23](#)

Configuring Call Hold: Example

The following example shows how to enable the Call Hold feature:

```
Gateway# configure terminal
Enter configuration commands, one per line. End with CNTL/Z.
Gateway(conf)# application
Gateway(config-app)# service dsapp
Gateway(config-app-param)# param callHold TRUE
```

Configuring Call Waiting: Example

The following example shows the configuration to enable the Call Waiting feature.

```
Gateway# configure terminal
Enter configuration commands, one per line. End with CNTL/Z.
Gateway(conf)# application
Gateway(config-app)# service dsapp
Gateway(config-app-param)# param callWaiting TRUE
```

Configuring Call Transfer: Example

The following example shows how to enable the Call Transfer feature:

```
Gateway# configure terminal
Enter configuration commands, one per line. End with CNTL/Z.
Gateway(conf)# application
Gateway(config-app)# service dsapp
Gateway(config-app-param)# param callTransfer TRUE
```

Configuring 3-Way Conferencing: Example

The following example shows how to enable the 3-Way Conferencing feature:

```
Gateway# configure terminal
Enter configuration commands, one per line. End with CNTL/Z.
Gateway(conf)# application
Gateway(config-app)# service dsapp
Gateway(config-app-param)# param callConference TRUE
```

Configuring Disconnect Toggle Time: Example

In this example, a disconnect toggle time is configured; the toggle time specifies the amount of time in seconds the system waits before committing the call transfer, after the originating call is placed on hook.

```
Gateway# configure terminal
Enter configuration commands, one per line. End with CNTL/Z.
Gateway(conf)# application
Gateway(config-app)# service dsapp
```

```
Gateway(config-app-param)# param disc-toggle-time 10
```

Configuring Blind Transfer Wait Time: Example

In this example, a blind transfer wait time is configured that specifies the amount of time in seconds the system waits before committing the call transfer after the originating call is placed on hook.

```
Gateway# configure terminal
Enter configuration commands, one per line. End with CNTL/Z.
Gateway(conf)# application
Gateway(config-app)# service dsapp
Gateway(config-app-param)# param blind-xfer-wait-time 10
```

Configuring a Fixed Dial Peer Used for Outgoing Calls on SIP Trunk Side: Example

In this example, a fixed dial peer is configured to set up the call to the SIP server (trunk) side.

```
Gateway# configure terminal
Enter configuration commands, one per line. End with CNTL/Z.
Gateway(conf)# application
Gateway(config-app)# service dsapp
Gateway(config-app-param)# param dialpeer 5000
```

Associating Services with a Fixed Dial Peer: Example

In this example, a fixed dial peer is configured to set up the call to the SIP server (trunk) side. The line in bold shows the dial peer statement.

```
Gateway# show running log
.
!
application
  service dsapp
  param dialpeer 1234
  param disc-toggle-time 15
  param callWaiting TRUE
  param callConference TRUE
  param blind-xfer-wait-time 10
  param callTransfer TRUE
!

voice-port 1/0/0
  station-id-name Example1
  station-id number 1234567890
!
voice-port 1/0/1
  station-id-name Example2
  station-id number 1234567891
!
voice-port 1/0/2
  station-id-name Example31
  station-id number 1234567892
!
dial-peer voice 1234 voip
  service dsapp
```

```

destination-pattern.T
session protocol sipv2
session target ipv4:10.1.1.1
dtmf-relay rtp-nte
codec g711ulaw
!
dial-peer voice 100 pots
service dsapp
destination-pattern.1234567890
port 1/0/0
prefix 1234567890
!
dial-peer voice 101 pots
service dsapp
destination-pattern.1234567891
port 1/0/1
prefix 1234567891
!
dial-peer voice 102 pots
service dsapp
destination-pattern.1234567892
port 1/0/2
prefix 1234567892
!
!
sip-ua
registrar ipv4:10.1.1.1 expires 3600
!

```

Associating Services Globally on a Gateway: Example

In this example, the gateway is associated globally with supplementary services. The lines in bold show the dial peer statement.

```

Gateway# show running log
.
!
application
service dsapp
param disc-toggle-time 15
param callWaiting TRUE
param callConference TRUE
param blind-xfer-wait-time 10
param callTransfer TRUE
!

voice-port 1/0/0
station-id-name Example1
station-id number 1234567890
!
voice-port 1/0/1
station-id-name Example2
station-id number 1234567891
!
voice-port 1/0/2
station-id-name Example31
station-id number 1234567892
!
dial-peer voice 1234 voip
service dsapp
destination-pattern 1800T
session protocol sipv2

```

```
session target ipv4:10.1.1.1
dtmf-relay rtp-nte
codec g729r8
!
dial-peer voice 9753 voip
service dsapp
destination-pattern.T
session protocol sipv2
session target ipv4:10.1.1.1
dtmf-relay rtp-nte
codec g711ulaw
!
dial-peer voice 100 pots
preference 8
service dsapp
destination-pattern.6234567890
port 1/0/0
prefix 6234567890
!
dial-peer voice 101 pots
preference 8
service dsapp
destination-pattern.6234567892
port 1/0/1
prefix 6234567892
!
dial-peer voice 102 pots
preference 8
service dsapp
destination-pattern.6234567893
port 1/0/2
prefix 6234567893
!
!
dial-peer hunt 2
!
sip-ua
registar ipv4:10.1.1.1 expires 3600
!
```

Additional References

The following sections provide references related to the SIP Support for Hookflash feature.

MIBs

MIB	MIBs Link
None	To locate and download MIBs for selected platforms, Cisco IOS releases, and feature sets, use Cisco MIB Locator found at the following URL: http://www.cisco.com/go/mibs

Technical Assistance

Description	Link
The Cisco Technical Support website contains thousands of pages of searchable technical content, including links to products, technologies, solutions, technical tips, and tools. Registered Cisco.com users can log in from this page to access even more content.	http://www.cisco.com/techsupport

CCVP, the Cisco logo, and Welcome to the Human Network are trademarks of Cisco Systems, Inc.; Changing the Way We Work, Live, Play, and Learn is a service mark of Cisco Systems, Inc.; and Access Registrar, Aironet, Catalyst, CCDA, CCDP, CCIE, CCIP, CCNA, CCNP, CCSP, Cisco, the Cisco Certified Internetwork Expert logo, Cisco IOS, Cisco Press, Cisco Systems, Cisco Systems Capital, the Cisco Systems logo, Cisco Unity, Enterprise/Solver, EtherChannel, EtherFast, EtherSwitch, Fast Step, Follow Me Browsing, FormShare, GigaDrive, HomeLink, Internet Quotient, IOS, iPhone, IP/TV, iQ Expertise, the iQ logo, iQ Net Readiness Scorecard, iQuick Study, LightStream, Linksys, MeetingPlace, MGX, Networkers, Networking Academy, Network Registrar, PIX, ProConnect, ScriptShare, SMARTnet, StackWise, The Fastest Way to Increase Your Internet Quotient, and TransPath are registered trademarks of Cisco Systems, Inc. and/or its affiliates in the United States and certain other countries.

All other trademarks mentioned in this document or Website are the property of their respective owners. The use of the word partner does not imply a partnership relationship between Cisco and any other company. (0711R)

Any Internet Protocol (IP) addresses used in this document are not intended to be actual addresses. Any examples, command display output, and figures included in the document are shown for illustrative purposes only. Any use of actual IP addresses in illustrative content is unintentional and coincidental.

© 2007 Cisco Systems, Inc. All rights reserved.

