



# RSVP Interface-Based Receiver Proxy

---

**First Published: July 10, 2006**

**Last Updated: October 2, 2009**

The RSVP Interface-Based Receiver Proxy feature lets you configure a proxy router by outbound interface instead of configuring a destination address for each flow going through the same interface.

## Finding Feature Information

Your software release may not support all the features documented in this module. For the latest feature information and caveats, see the release notes for your platform and software release. To find information about the features documented in this module, and to see a list of the releases in which each feature is supported, see the “[Feature Information for RSVP Interface-Based Receiver Proxy](#)” section on page 12.

Use Cisco Feature Navigator to find information about platform support and Cisco IOS and Catalyst OS software image support. To access Cisco Feature Navigator, go to <http://www.cisco.com/go/cfn>. An account on Cisco.com is not required.

## Contents

- [Prerequisites for RSVP Interface-Based Receiver Proxy, page 2](#)
- [Restrictions for RSVP Interface-Based Receiver Proxy, page 2](#)
- [Information About RSVP Interface-Based Receiver Proxy, page 2](#)
- [How to Configure RSVP Interface-Based Receiver Proxy, page 3](#)
- [Configuration Examples for RSVP Interface-Based Receiver Proxy, page 6](#)
- [Additional References, page 9](#)
- [Feature Information for RSVP Interface-Based Receiver Proxy, page 12](#)
- [Glossary, page 13](#)



---

**Americas Headquarters:**  
**Cisco Systems, Inc., 170 West Tasman Drive, San Jose, CA 95134-1706 USA**

© 2006–2009 Cisco Systems, Inc. All rights reserved.

## Prerequisites for RSVP Interface-Based Receiver Proxy

You must configure an IP address and enable Resource Reservation Protocol (RSVP) on one or more interfaces on at least two neighboring routers that share a link within the network.

## Restrictions for RSVP Interface-Based Receiver Proxy

- Filtering using access control lists (ACLs), application IDs, or other mechanisms is not supported.
- A provider edge (PE) router cannot switch from being a proxy node to a transit node for a given flow during the lifetime of the flow.

## Information About RSVP Interface-Based Receiver Proxy

To use the RSVP Interface-Based Receiver Proxy feature, you should understand the following concepts:

- [Feature Overview of RSVP Interface-Based Receiver Proxy, page 2](#)
- [Benefits of RSVP Interface-Based Receiver Proxy, page 3](#)

## Feature Overview of RSVP Interface-Based Receiver Proxy

The RSVP Interface-Based Receiver Proxy feature allows you to use RSVP to signal reservations and guarantee bandwidth on behalf of a receiver that does not support RSVP, by terminating the PATH message and generating a RESV message in the upstream direction on an RSVP-capable router on the path to the endpoint. An example is a video-on-demand flow from a video server to a set-top box, which is a computer that acts as a receiver and decodes the incoming video signal from the video server.

Because set-top boxes may not support RSVP natively, you cannot configure end-to-end RSVP reservations between a video server and a set-top box. Instead, you can enable the RSVP interface-based receiver proxy on the router that is closest to that set-top box.

The router terminates the end-to-end sessions for many set-top boxes and performs admission control on the outbound (or egress) interface of the PATH message, where the receiver proxy is configured, as a proxy for Call Admission Control (CAC) on the router-to-set-top link. The RSVP interface-based receiver proxy determines which PATH messages to terminate by looking at the outbound interface to be used by the traffic flow.

You can configure an RSVP interface-based receiver proxy to terminate PATH messages going out a specified interface with a specific action (reply with RESV, or reject). The most common application is to configure the receiver proxy on the edge of an administrative domain on interdomain interfaces. The router then terminates PATH messages going out the administrative domain while still permitting PATH messages transitioning through the router within the same administrative domain to continue downstream.

In the video-on-demand example described above, the last-hop Layer 3 router supporting RSVP implements the receiver proxy, which is then configured on the interfaces facing the Layer 2 distribution network (for example, Digital Subscriber Line access [DSLAM] or cable distribution). Also, since RSVP is running and performing CAC on the router with the receiver proxy, you can configure RSVP enhancements such as local policy and Common Open Policy Service (COPS) for more fine-grained control on video flow CAC.

The router terminates the end-to-end sessions for many set-top boxes, with the assumption that the links further downstream (for example, from the DSLAM to the set-top box) never become congested or, more likely, in the case of congestion, that the voice and video traffic from the router gets the highest priority and access to the bandwidth.

## Benefits of RSVP Interface-Based Receiver Proxy

### Ease of Use and Scalability Improvement

Previously, you had to configure a receiver proxy for every separate RSVP stream or set-top box. Now you can configure the proxy by outbound interface. For example, if there were 100 set-top boxes downstream from the proxy router, you had to configure 100 proxies. With this enhancement, you configure only the outbound interface(s). In addition, the receiver proxy is guaranteed to terminate the reservation only on the last hop within the core network. Nodes that may function as transit nodes for some PATH messages but should proxy others depending on their placement in the network can perform the correct functions on a flow-by-flow basis.

In the video-on-demand example described above, a PATH message that transits through an edge router to another edge router (around the edge) is not terminated, whereas an otherwise identical PATH message that actually exits the aggregation network and transitions to the access network is terminated. This allows for more accurate CAC in the network and also simplifies and reduces configuration requirements.

## How to Configure RSVP Interface-Based Receiver Proxy

This section contains the following procedures:

- [Enabling RSVP on an Interface, page 3](#) (required)
- [Configuring a Receiver Proxy on an Outbound Interface, page 4](#) (required)
- [Verifying the RSVP Interface-Based Receiver Proxy Configuration, page 5](#) (optional)

## Enabling RSVP on an Interface

Perform this task to enable RSVP on an interface.

### SUMMARY STEPS

1. **enable**
2. **configure terminal**
3. **interface** *interface number*
4. **ip rsvp bandwidth** [*interface-kbps*] [*single-flow-kbps*] [**sub-pool** [*sub-pool-kbps*]]
5. **end**

## DETAILED STEPS

	Command or Action	Purpose
Step 1	<b>enable</b>  <b>Example:</b> Router> enable	Enables privileged EXEC mode. <ul style="list-style-type: none"> <li>Enter your password if prompted.</li> </ul>
Step 2	<b>configure terminal</b>  <b>Example:</b> Router# configure terminal	Enters global configuration mode.
Step 3	<b>interface</b> <i>interface number</i>  <b>Example:</b> Router(config)# interface Ethernet0/0	Configures the interface type and enters interface configuration mode.
Step 4	<b>ip rsvp bandwidth</b> [ <i>interface-kbps</i> ] [ <i>single-flow-kbps</i> ] [ <b>sub-pool</b> [ <i>sub-pool-kbps</i> ]]  <b>Example:</b> Router(config-if)# ip rsvp bandwidth 7500 7500	Enables RSVP on an interface. <ul style="list-style-type: none"> <li>The optional <i>interface-kbps</i> and <i>single-flow-kbps</i> arguments specify the amount of bandwidth that can be allocated by RSVP flows or to a single flow, respectively. Values are from 1 to 10000000.</li> <li>The optional <b>sub-pool</b> and <i>sub-pool-kbps</i> keyword and argument specify subpool traffic and the amount of bandwidth that can be allocated by RSVP flows. Values are from 1 to 10000000.</li> </ul> <p><b>Note</b> Repeat this command for each interface on which you want to enable RSVP.</p>
Step 5	<b>end</b>  <b>Example:</b> Router(config-if)# end	(Optional) Returns to privileged EXEC mode.

## Configuring a Receiver Proxy on an Outbound Interface

Perform this task to configure a receiver proxy on an outbound interface.

## SUMMARY STEPS

- enable**
- configure terminal**
- interface** *interface number*
- ip rsvp listener outbound** {reply | reject}
- end**

## DETAILED STEPS

	Command or Action	Purpose
Step 1	<b>enable</b>  <b>Example:</b> Router> enable	Enables privileged EXEC mode. <ul style="list-style-type: none"> <li>Enter your password if prompted.</li> </ul>
Step 2	<b>configure terminal</b>  <b>Example:</b> Router# configure terminal	Enters global configuration mode.
Step 3	<b>interface</b> <i>interface number</i>  <b>Example:</b> Router(config)# interface Ethernet0/0	Configures the interface type and enters interface configuration mode.
Step 4	<b>ip rsvp listener outbound {reply   reject}</b>  <b>Example:</b> Router(config-if)# ip rsvp listener outbound reject	Configures an RSVP router to listen for PATH messages sent through a specified interface. <ul style="list-style-type: none"> <li>Enter the <b>reply</b> keyword or the <b>reject</b> keyword to specify the response that you want to PATH messages.</li> </ul>
Step 5	<b>end</b>  <b>Example:</b> Router(config-if)# end	(Optional) Returns to privileged EXEC mode.

## Verifying the RSVP Interface-Based Receiver Proxy Configuration

Perform the following task to verify the configuration.

**Note**

You can use the following **show** commands in user EXEC or privileged EXEC mode.

## SUMMARY STEPS

- enable**
- show ip rsvp listeners** [*dst* | **any** | **vrf** {*\** | *vrf-name*}] [**udp** | **tcp** | **any** | *protocol*] [*dst-port* | **any**]
- show ip rsvp sender** [**vrf** {*\** | *vrf-name*}] [**detail**] [**filter** [**destination** *ip-addr* | *hostname*] [**source** *ip-addr* | *hostname*] [**dst-port** *port*] [**src-port** *port*]]
- show ip rsvp reservation** [**vrf** {*\** | *vrf-name*}] [**detail**] [**filter** [**destination** *ip-addr* | *hostname*] [**source** *ip-addr* | *hostname*] [**dst-port** *port*] [**src-port** *port*]]
- exit**

## DETAILED STEPS

	Command or Action	Purpose
Step 1	<p><b>enable</b></p> <p><b>Example:</b> Router&gt; enable</p>	<p>(Optional) Enables privileged EXEC mode.</p> <ul style="list-style-type: none"> <li>Enter your password if prompted.</li> </ul> <p><b>Note</b> Skip this step if you are using the <b>show</b> commands in user EXEC mode.</p>
Step 2	<p><b>show ip rsvp listeners</b> [<i>dst</i>   <b>any</b>   <b>vrf</b> {<i>*</i>   <i>vrf-name</i>}] [<b>udp</b>   <b>tcp</b>   <b>any</b>   <i>protocol</i>] [<i>dst-port</i>   <b>any</b>]</p> <p><b>Example:</b> Router# show ip rsvp listeners</p>	<p>Displays RSVP listeners for a specified port or protocol.</p>
Step 3	<p><b>show ip rsvp sender</b> [<b>vrf</b> {<i>*</i>   <i>vrf-name</i>}] [<b>detail</b>] [<b>filter</b> [<b>destination</b> <i>ip-addr</i>   <i>hostname</i>] [<b>source</b> <i>ip-addr</i>   <i>hostname</i>] [<b>dst-port</b> <i>port</i>] [<b>src-port</b> <i>port</i>]]</p> <p><b>Example:</b> Router# show ip rsvp sender detail</p>	<p>Displays RSVP PATH-related sender information currently in the database.</p> <ul style="list-style-type: none"> <li>The optional <b>detail</b> keyword displays additional output.</li> </ul> <p><b>Note</b> The optional <b>filter</b> keyword is supported in Cisco IOS Releases 12.0S and 12.2S only.</p>
Step 4	<p><b>show ip rsvp reservation</b> [<b>vrf</b> {<i>*</i>   <i>vrf-name</i>}] [<b>detail</b>] [<b>filter</b> [<b>destination</b> <i>ip-addr</i>   <i>hostname</i>] [<b>source</b> <i>ip-addr</i>   <i>hostname</i>] [<b>dst-port</b> <i>port</i>] [<b>src-port</b> <i>port</i>]]</p> <p><b>Example:</b> Router# show ip rsvp reservation detail</p>	<p>Displays RSVP-related receiver information currently in the database.</p> <ul style="list-style-type: none"> <li>The optional <b>detail</b> keyword displays additional output.</li> </ul> <p><b>Note</b> The optional <b>filter</b> keyword is supported in Cisco IOS Releases 12.0S and 12.2S only.</p>
Step 5	<p><b>exit</b></p> <p><b>Example:</b> Router# exit</p>	<p>(Optional) Exits privileged EXEC mode and returns to user EXEC mode.</p>

## Configuration Examples for RSVP Interface-Based Receiver Proxy

This section provides the following configuration examples:

- [Configuring RSVP Interface-Based Receiver Proxy: Examples, page 6](#)
- [Verifying RSVP Interface-Based Receiver Proxy: Examples, page 7](#)

### Configuring RSVP Interface-Based Receiver Proxy: Examples

The four-router network in [Figure 1](#) contains the following configurations:

- [Configuring a Receiver Proxy \(Listener\) on a Middle Router on Behalf of Tailend Routers, page 7](#)
- [Configuring PATH Messages from a Headend Router to Tailend Routers to Test the Receiver Proxy, page 7](#)

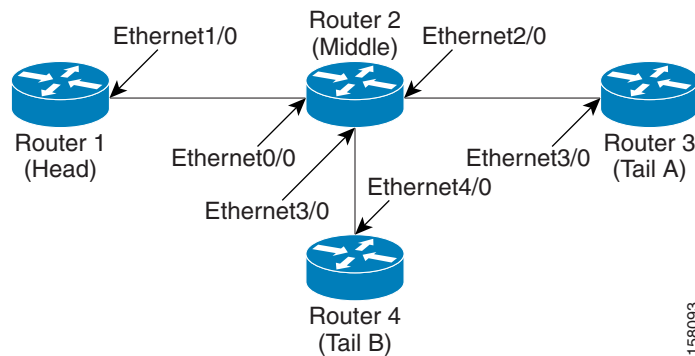
**Figure 1** Sample Network with an Interface-Based Receiver Proxy Configured**Configuring a Receiver Proxy (Listener) on a Middle Router on Behalf of Tailend Routers**

The following example configures a receiver proxy, also called a listener, on the middle router (Router 2) on behalf of the two tailend routers (Routers 3 and 4):

```
Router# configure terminal
Enter configuration commands, one per line. End with CNTL/Z.
Router(config)# interface ethernet 2/0
Router(config-if)# ip rsvp listener outbound reply
Router(config-if)# exit
Router(config)# interface ethernet 3/0
Router(config-if)# ip rsvp listener outbound reject
Router(config-if)# end
```

**Configuring PATH Messages from a Headend Router to Tailend Routers to Test the Receiver Proxy****Note**

If you do not have another headend router generating RSVP PATH messages available, configure one in the network for the specific purpose of testing RSVP features such as the receiver proxy. Note that these commands are not expected (or supported) in a final deployment.

The following example configures four PATH messages from the headend router (Router 1) to the tailend routers (Routers 3 and 4):

```
Router# configure terminal
Enter configuration commands, one per line. End with CNTL/Z.
Router(config)# ip rsvp sender-host 10.0.0.5 10.0.0.1 TCP 2 2 100 10
Router(config)# ip rsvp sender-host 10.0.0.5 10.0.0.1 UDP 1 1 100 10
Router(config)# ip rsvp sender-host 10.0.0.7 10.0.0.1 TCP 4 4 100 10
Router(config)# ip rsvp sender-host 10.0.0.7 10.0.0.1 UDP 3 3 100 10
Router(config)# end
```

## Verifying RSVP Interface-Based Receiver Proxy: Examples

This section contains the following verification examples:

- [Verifying the PATH Messages in the Database, page 8](#)
- [Verifying the Running Configuration, page 8](#)
- [Verifying the Listeners \(Proxies\), page 9](#)
- [Verifying the Reservations, page 9](#)
- [Verifying CAC on an Outbound Interface, page 9](#)

### Verifying the PATH Messages in the Database

The following example verifies that the PATH messages you configured are in the database:

```
Router# show ip rsvp sender
```

To	From	Pro	DPort	Sport	Prev Hop	I/F	BPS
10.0.0.5	10.0.0.1	TCP	2	2	none	none	100K
10.0.0.5	10.0.0.1	UDP	1	1	none	none	100K
10.0.0.7	10.0.0.1	TCP	4	4	none	none	100K
10.0.0.7	10.0.0.1	UDP	3	3	none	none	100K

The following example verifies that a PATH message has been terminated by a receiver proxy configured to reply.



#### Note

A receiver proxy that is configured to reject does not cause any state to be stored in the RSVP database; therefore, this **show** command does not display these PATHS. Only one PATH message is shown.

```
Router# show ip rsvp sender detail
```

```
PATH:
  Destination 10.0.0.5, Protocol_Id 17, Don't Police , DstPort 1
  Sender address: 10.0.0.1, port: 1
  Path refreshes:
    arriving: from PHOP 10.1.2.1 on Et0/0 every 30000 msec
  Traffic params - Rate: 100K bits/sec, Max. burst: 10K bytes
    Min Policed Unit: 0 bytes, Max Pkt Size 2147483647 bytes
  Path ID handle: 01000402.
  Incoming policy: Accepted. Policy source(s): Default
  Status: Proxy-terminated
  Output on Ethernet2/0. Policy status: NOT Forwarding. Handle: 02000401
  Policy source(s):
  Path FLR: Never repaired
```

### Verifying the Running Configuration

The following example verifies the configuration for Ethernet interface 2/0:

```
Router# show running-config interface Ethernet2/0
```

```
Building configuration...

Current configuration : 132 bytes
!
interface Ethernet2/0
 ip address 172.16.0.1 255.0.0.0
 no cdp enable
 ip rsvp bandwidth 2000
 ip rsvp listener outbound reply
end
```

The following example verifies the configuration for Ethernet interface 3/0:

```
Router# show running-config interface Ethernet3/0
```

```
Building configuration...

Current configuration : 133 bytes
!
interface Ethernet3/0
 ip address 172.16.0.2 255.0.0.0
```

```

no cdp enable
ip rsvp bandwidth 2000
ip rsvp listener outbound reject
end

```

### Verifying the Listeners (Proxies)

The following example verifies the listeners (proxies) that you configured on the middle router (Router 2) on behalf of the two tailend routers (Routers 3 and 4):

To	Protocol	DPort	Description	Action	OutIf
10.0.0.0	0	0	RSVP Proxy	reply	Et2/0
10.0.0.0	0	0	RSVP Proxy	reject	Et3/0

### Verifying the Reservations

The following example displays reservations established by the middle router (Router 2) on behalf of the tailend routers (Routers 3 and 4) as seen from the headend router (Router 1):

```
Router# show ip rsvp reservation
```

To	From	Pro	DPort	Sport	Next Hop	I/F	Fi	Serv	BPS
10.0.0.7	10.0.0.1	TCP	4	4	10.0.0.2	Et1/0	FF	RATE	100K
10.0.0.7	10.0.0.1	UDP	3	3	10.0.0.2	Et1/0	FF	RATE	100K

The following example verifies that a reservation is locally generated (proxied). Only one reservation is shown:

```
Router# show ip rsvp reservation detail
```

```

RSVP Reservation. Destination is 10.0.0.7, Source is 10.0.0.1,
  Protocol is UDP, Destination port is 1, Source port is 1
  Next Hop: 10.2.3.3 on Ethernet2/0
  Reservation Style is Fixed-Filter, QoS Service is Guaranteed-Rate
  Resv ID handle: 01000405.
  Created: 09:24:24 EST Fri Jun 2 2006
  Average Bitrate is 100K bits/sec, Maximum Burst is 10K bytes
  Min Policed Unit: 0 bytes, Max Pkt Size: 0 bytes
  Status: Proxied
  Policy: Forwarding. Policy source(s): Default

```

### Verifying CAC on an Outbound Interface

The following example verifies that the proxied reservation performed CAC on the local outbound interface:

```
Router# show ip rsvp installed
```

```

RSVP: Ethernet3/0 has no installed reservations
RSVP: Ethernet2/0
BPS   To           From           Protoc DPort  Sport
100K  10.0.0.7       10.0.0.1       UDP    1      1

```

## Additional References

The following sections provide references related to the RSVP Interface-Based Receiver Proxy feature.

## Related Documents

Related Topic	Document Title
QoS commands: complete command syntax, command modes, command history, defaults, usage guidelines, and examples	<a href="#">Cisco IOS Quality of Service Solutions Command Reference</a>
QoS configuration tasks related to RSVP	“Configuring RSVP” module
Internet draft	<i>RSVP Proxy Approaches</i> , Internet draft, October 2006 [draft-lefaucheur-tsvwg-rsvp-proxy-00.txt]

## Standards

Standard	Title
No new or modified standards are supported by this feature, and support for existing standards has not been modified by this feature.	—

## MIBs

MIB	MIBs Link
No new or modified MIBs are supported by this feature, and support for existing MIBs has not been modified by this feature.	To locate and download MIBs for selected platforms, Cisco IOS releases, and feature sets, use Cisco MIB Locator found at the following URL: <a href="http://www.cisco.com/go/mibs">http://www.cisco.com/go/mibs</a>

## RFCs

RFC	Title
RFC 2205	Resource ReSerVation Protocol (RSVP)

## Technical Assistance

Description	Link
<p>The Cisco Support website provides extensive online resources, including documentation and tools for troubleshooting and resolving technical issues with Cisco products and technologies.</p> <p>To receive security and technical information about your products, you can subscribe to various services, such as the Product Alert Tool (accessed from Field Notices), the Cisco Technical Services Newsletter, and Really Simple Syndication (RSS) Feeds.</p> <p>Access to most tools on the Cisco Support website requires a Cisco.com user ID and password.</p>	<p><a href="http://www.cisco.com/techsupport">http://www.cisco.com/techsupport</a></p>

# Feature Information for RSVP Interface-Based Receiver Proxy

Table 1 lists the release history for this feature.

Not all commands may be available in your Cisco IOS software release. For release information about a specific command, see the command reference documentation.

Use Cisco Feature Navigator to find information about platform support and software image support. Cisco Feature Navigator enables you to determine which Cisco IOS and Catalyst OS software images support a specific software release, feature set, or platform. To access Cisco Feature Navigator, go to <http://www.cisco.com/go/cfn>. An account on Cisco.com is not required.



## Note

Table 1 lists only the Cisco IOS software release that introduced support for a given feature in a given Cisco IOS software release train. Unless noted otherwise, subsequent releases of that Cisco IOS software release train also support that feature.

**Table 1** Feature Information for RSVP Interface-Based Receiver Proxy

Feature Name	Releases	Feature Information
RSVP Interface-Based Receiver Proxy	12.2(28)SXF5 12.2(33)SRB, 15.0(1)M	<p>The RSVP Interface-Based Receiver Proxy feature lets you configure a proxy router by outbound interface instead of configuring a destination address for each flow going through the same interface.</p> <p>In Cisco IOS Release 12.2(33)SRB, support was added for the Cisco 7600 series routers.</p> <p>This feature was integrated into Cisco IOS Release 15.0(1)M.</p> <p>The following commands were introduced or modified: <b>ip rsvp bandwidth</b>, <b>ip rsvp listener outbound</b>, <b>show ip rsvp listeners</b>, <b>show ip rsvp reservation</b>, <b>show ip rsvp sender</b>.</p>

# Glossary

**flow**—A stream of data traveling between two endpoints across a network (for example, from one LAN station to another). Multiple flows can be transmitted on a single circuit.

**PE router**—provider edge router. A router that is part of a service provider's network and is connected to a customer edge (CE) router.

**proxy**—A component of RSVP that manages all locally originated and terminated state.

**receiver proxy**—A configurable feature that allows a router to proxy RSVP RESV messages for local or remote destinations.

**RSVP**—Resource Reservation Protocol. A protocol for reserving network resources to provide quality of service guarantees to application flows.

**set-top box**—A computer that acts as a receiver and decodes the incoming signal from a satellite dish, a cable network, or a telephone line.

---

CCDE, CCENT, CCSI, Cisco Eos, Cisco HealthPresence, Cisco IronPort, the Cisco logo, Cisco Lumin, Cisco Nexus, Cisco Nurse Connect, Cisco Pulse, Cisco StackPower, Cisco StadiumVision, Cisco TelePresence, Cisco Unified Computing System, Cisco WebEx, DCE, Flip Channels, Flip for Good, Flip Mino, Flipshare (Design), Flip Ultra, Flip Video, Flip Video (Design), Instant Broadband, and Welcome to the Human Network are trademarks; Changing the Way We Work, Live, Play, and Learn, Cisco Capital, Cisco Capital (Design), Cisco:Financed (Stylized), Cisco Store, and Flip Gift Card are service marks; and Access Registrar, Aironet, AllTouch, AsyncOS, Bringing the Meeting To You, Catalyst, CCDA, CCDP, CCIE, CCIP, CCNA, CCNP, CCSP, CCVP, Cisco, the Cisco Certified Internetwork Expert logo, Cisco IOS, Cisco Press, Cisco Systems, Cisco Systems Capital, the Cisco Systems logo, Cisco Unity, Collaboration Without Limitation, Continuum, EtherFast, EtherSwitch, Event Center, Explorer, Fast Step, Follow Me Browsing, FormShare, GainMaker, GigaDrive, HomeLink, iLYNX, Internet Quotient, IOS, iPhone, iQuick Study, IronPort, the IronPort logo, Laser Link, LightStream, Linksys, MediaTone, MeetingPlace, MeetingPlace Chime Sound, MGX, Networkers, Networking Academy, Network Registrar, PCNow, PIX, PowerKEY, PowerPanels, PowerTV, PowerTV (Design), PowerVu, Prisma, ProConnect, ROSA, ScriptShare, SenderBase, SMARTnet, Spectrum Expert, StackWise, The Fastest Way to Increase Your Internet Quotient, TransPath, WebEx, and the WebEx logo are registered trademarks of Cisco Systems, Inc. and/or its affiliates in the United States and certain other countries.

---

All other trademarks mentioned in this document or website are the property of their respective owners. The use of the word partner does not imply a partnership relationship between Cisco and any other company. (0908R)

Any Internet Protocol (IP) addresses used in this document are not intended to be actual addresses. Any examples, command display output, and figures included in the document are shown for illustrative purposes only. Any use of actual IP addresses in illustrative content is unintentional and coincidental.

© 2006–2009 Cisco Systems, Inc. All rights reserved.

