



NetFlow Layer 2 and Security Monitoring Exports

First Published: June 19, 2006

Last Updated: July 28, 2009

The NetFlow Layer 2 and Security Monitoring Exports feature improves your ability to detect and analyze network threats such as denial of service (DoS) attacks by increasing the number of fields from which NetFlow can capture values.

NetFlow is a Cisco IOS technology that provides statistics on packets flowing through a router. NetFlow is the standard for acquiring IP operational data from IP networks. NetFlow provides network and security monitoring, network planning, traffic analysis, and IP accounting.

Finding Feature Information

Your software release may not support all the features documented in this module. For the latest feature information and caveats, see the release notes for your platform and software release. To find information about the features documented in this module, and to see a list of the releases in which each feature is supported, use the “[Feature Information for NetFlow Layer 2 and Security Monitoring Exports](#)” section on [page 34](#).

Use Cisco Feature Navigator to find information about platform support and Cisco IOS and Catalyst OS software image support. To access Cisco Feature Navigator, go to <http://www.cisco.com/go/cfn>. An account on Cisco.com is not required.

Contents

- [Prerequisites for NetFlow Layer 2 and Security Monitoring Exports, page 2](#)
- [Restrictions for NetFlow Layer 2 and Security Monitoring Exports, page 2](#)
- [Information About NetFlow Layer 2 and Security Monitoring Exports, page 2](#)
- [How to Configure NetFlow Layer 2 and Security Monitoring Exports, page 14](#)
- [Configuration Examples for NetFlow Layer 2 and Security Monitoring Exports, page 19](#)
- [Additional References, page 33](#)



Americas Headquarters:
Cisco Systems, Inc., 170 West Tasman Drive, San Jose, CA 95134-1706 USA

© 2008 Cisco Systems, Inc. All rights reserved.

- [Feature Information for NetFlow Layer 2 and Security Monitoring Exports, page 34](#)
- [Glossary, page 36](#)

Prerequisites for NetFlow Layer 2 and Security Monitoring Exports

Before you configure NetFlow Layer 2 and Security Monitoring Exports, you should understand NetFlow accounting and how to configure your router to capture IP traffic accounting statistics using NetFlow. See the “[Cisco IOS NetFlow Overview](#)” and “[Configuring NetFlow and NetFlow Data Export](#)” modules for more details.

NetFlow and Cisco Express Forwarding (CEF), distributed CEF (dCEF), or fast switching must be configured on your system.

Restrictions for NetFlow Layer 2 and Security Monitoring Exports

If you want to export the data captured with the NetFlow Layer 2 and Security Monitoring feature, you must configure NetFlow to use the NetFlow Version 9 data export format.

Information About NetFlow Layer 2 and Security Monitoring Exports

To configure NetFlow Layer 2 and Security Monitoring Exports, you should understand the following concepts:

- [NetFlow Layer 2 and Security Monitoring, page 2](#)
- [NBAR Data Export, page 13](#)

NetFlow Layer 2 and Security Monitoring

The Layer 2 and Layer 3 fields supported by the NetFlow Layer 2 and Security Monitoring Exports feature increase the amount of information that can be obtained by NetFlow about the traffic in your network. You can use this new information for applications such as traffic engineering and usage-based billing.

The Layer 3 IP header fields for which the NetFlow Layer 2 and Security Monitoring Exports feature captures the values are as follows:

- Time-to-live (TTL) field
- Packet length field
- ID field
- ICMP type and code fields
- Fragment offset

See the “[Layer 3 Information Capture Using NetFlow Layer 2 and Security Monitoring Exports](#)” section for more information on these Layer 3 fields.

The Layer 2 fields for which NetFlow Layer 2 and Security Monitoring Exports feature captures the values are as follows:

- Source MAC address field from frames that are received by the NetFlow router
- Destination MAC address field from frames that are transmitted by the NetFlow router
- VLAN ID field from frames that are received by the NetFlow router
- VLAN ID field from frames that are transmitted by the NetFlow router

See the “[Layer 2 Information Capture Using NetFlow Layer 2 and Security Monitoring Exports](#)” section for more information about these Layer 2 fields.

The Layer 3 fields captured by the NetFlow Layer 2 and Security Monitoring Exports feature improve the capabilities of NetFlow for identifying DoS attacks. The Layer 2 fields captured by the NetFlow Layer 2 and Security Monitoring Exports feature can help you identify the path that the DoS attack is taking through the network.

The Layer 2 and Layer 3 fields captured by the NetFlow Layer 2 and Security Monitoring Exports feature are not key fields. They provide additional information about the traffic in an existing flow. Changes in the values of NetFlow key fields such as the source IP address from one packet to the next packet result in the creation of a new flow. For example, if the first packet captured by NetFlow has a source IP address of 10.34.0.2 and the second packet captured has a source IP address of 172.16.213.65, then NetFlow will create two separate flows.

Many DoS attacks consist of an attacker sending the same type of IP datagram again and again in an attempt to overwhelm the target systems. In such cases the incoming traffic often has similar characteristics, such as the same values in each datagram for one or more of the fields that the NetFlow Layer 2 and Security Monitoring Exports feature can capture.

There is no easy way to identify the originator of many DoS attacks because the IP source address of the device sending the traffic is usually forged. However, you can easily trace the traffic back through the network to the router on which it is arriving by capturing the MAC address and VLAN-ID fields using the NetFlow Layer 2 and Security Monitoring Exports feature. If the router on which the traffic is arriving supports NetFlow, you can configure the NetFlow Layer 2 and Security Monitoring Exports feature on it to identify the interface where the traffic is arriving. [Figure 1](#) shows an example of an attack in progress.

Figure 1 DoS Attack Arriving over the Internet

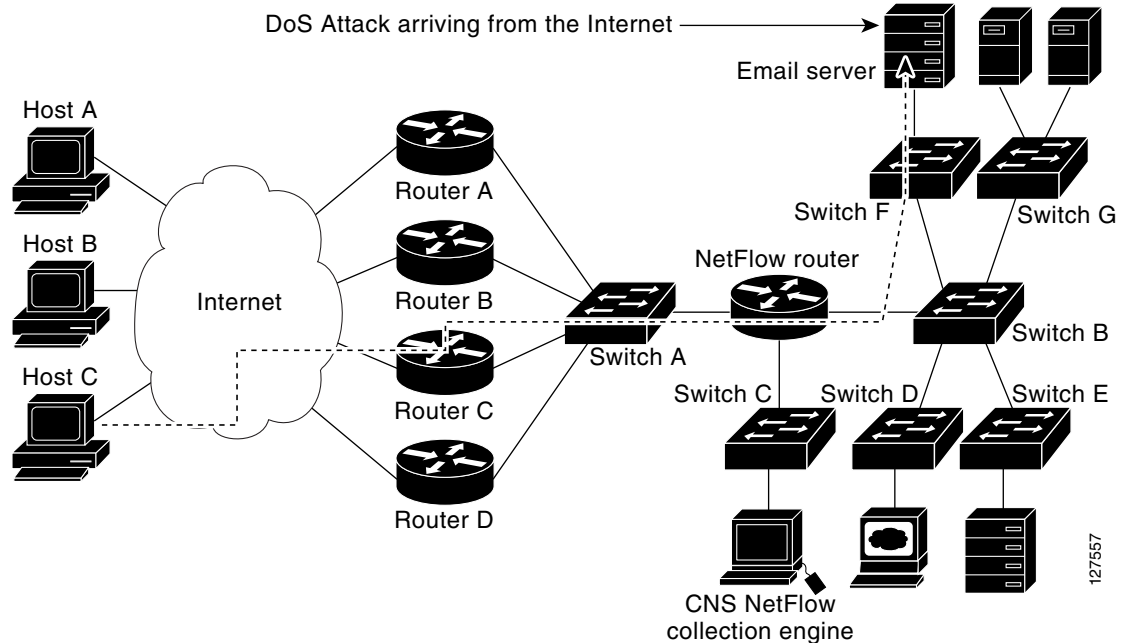

Note

You can analyze the data captured by NetFlow directly from the router using the **show ip cache verbose flow** command or the CNS NetFlow Collector Engine.

Once you have concluded that a DoS attack is taking place by analyzing the Layer 3 fields in the NetFlow flows, you can analyze the Layer 2 fields in the flows to discover the path that the DoS attack is taking through the network.

An analysis of the data captured by the NetFlow Layer 2 and Security Monitoring Exports feature for the scenario shown in Figure 1 indicates that the DoS attack is arriving on Router C because the upstream MAC address is from the interface that connects Router C to Switch A. It is also evident that there are no routers between the target host (the e-mail server) and the NetFlow router because the destination MAC address of the DoS traffic that the NetFlow router is forwarding to the email server is the MAC address of the e-mail server.

You can find out the MAC address that Host C is using to send the traffic to Router C by configuring the NetFlow Layer 2 and Security Monitoring Exports feature on Router C. The source MAC address will be from Host C. The destination MAC address will be for the interface on the NetFlow router.

Once you know the MAC address that Host C is using and the interface on Router C on which Host C's DoS attack is arriving, you can mitigate the attack by reconfiguring Router C to block Host C's traffic. If Host C is on a dedicated interface, you disable the interface. If Host C is using an interface that carries traffic from other users, you must configure your firewall to block Host C's traffic but still allow the traffic from the other users to flow through Router C.

The "[Configuration Examples for NetFlow Layer 2 and Security Monitoring Exports](#)" section has two examples for using the NetFlow Layer 2 and Security Monitoring Exports feature to identify an attack in progress and the path that the attack is taking through a network.

Layer 3 Information Capture Using NetFlow Layer 2 and Security Monitoring Exports

The NetFlow Layer 2 and Security Monitoring Exports feature has support for capturing five fields from Layer 3 IP traffic in a flow:

- Time-to-live field
- Packet length field
- ID field
- ICMP type and code
- Fragment offset

Figure 2 shows the fields in an IP packet header.

Figure 2 IP Packet Header Fields

00	01	02	03	04	05	06	07	08	09	10	11	12	13	14	15	16	17	18	19	20	21	22	23	24	25	26	27	28	29	30	31
Version		IHL		ToS				Total Length																							
Identification										Flags		Fragment Offset																			
TTL				Protocol				Header Checksum																							
Source IP Address																															
Destination IP Address																															
Options and Padding																															

127754

Table 1 describes the header fields in Figure 2.

Table 1 IP Packet Header Fields

Field	Description
Version	The version of the IP protocol. If this field is set to 4 it is an IPv4 datagram. If this field is set to 6 it is an IPv6 datagram. Note The IPv6 header has a different structure from an IPv4 header.
IHL (Internet Header Length)	Internet Header Length is the length of the Internet header in 32-bit word format and thus points to the beginning of the data. Note The minimum value for a correct header is 5.
ToS	Type of service (ToS) provides an indication of the abstract parameters of the quality of service desired. These parameters are to be used to guide the selection of the actual service parameters when a networking device transmits a datagram through a particular network.
Total Length	Total length is the length of the datagram, measured in octets, including Internet header and data.

Table 1 *IP Packet Header Fields (continued)*

Field	Description
Identification (ID)	<p>The value in the ID field is entered by the sender. All of the fragments of an IP datagram have the same value in the ID field. Subsequent IP datagrams from the same sender will have different values in the ID field.</p> <p>It is very common for a host to be receiving fragmented IP datagrams from several senders concurrently. It is also common for a host to be receiving multiple IP datagrams from the same sender concurrently.</p> <p>The value in the ID field is used by the destination host to ensure that the fragments of an IP datagram are assigned to the same packet buffer during the IP datagram reassembly process. The unique value in the ID field is also used to prevent the receiving host from mixing together IP datagram fragments of different IP datagrams from the same sender during the IP datagram reassembly process.</p>
Flags	<p>A sequence of 3 bits used to set and track IP datagram fragmentation parameters.</p> <ul style="list-style-type: none"> • 001 = The IP datagram can be fragmented. There are more fragments of the current IP datagram in transit. • 000 = The IP datagram can be fragmented. This is the last fragment of the current IP datagram. • 010 = The IP Datagram cannot be fragmented. This is the entire IP datagram.
Fragment Offset	This field indicates where in the datagram this fragment belongs.
TTL (Time-to-Live)	This field indicates the maximum time the datagram is allowed to remain in the Internet system. If this field contains the value 0, then the datagram must be destroyed. This field is modified in Internet header processing. The time is measured in units of seconds, but since every module that processes a datagram must decrease the TTL by at least 1 even if it processes the datagram in less than a second, the TTL must be thought of only as an upper bound on the time a datagram can exist. The intention is to cause undeliverable datagrams to be discarded and to bound the maximum datagram lifetime.
Protocol	<p>Indicates the type of transport packet included in the data portion of the IP datagram. Common values are:</p> <p>1 = ICMP</p> <p>6 = TCP</p> <p>17 = UDP</p>
Header checksum	A checksum on the header only. Since some header fields, such as the time-to-live field, change every time an IP datagram is forwarded, this value is recomputed and verified at each point that the Internet header is processed.
Source IP Address	IP address of the sending station.

Table 1 *IP Packet Header Fields (continued)*

Field	Description
Destination IP Address	IP address of the destination station.
Options and Padding	The options and padding may or may not appear or not in datagrams. If they do appear, they must be implemented by all IP modules (host and gateways). What is optional is their transmission in any particular datagram, not their implementation.

Figure 3 shows the fields in an ICMP datagram.

Figure 3 *ICMP Datagram*

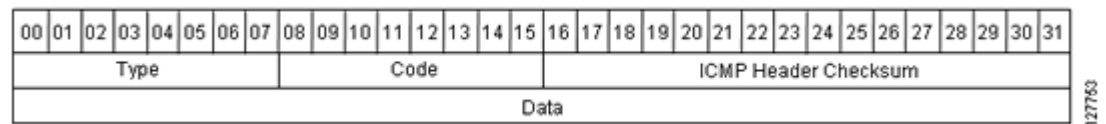

Table 2 interprets the packet format in Figure 3. ICMP datagrams are carried in the data area of an IP datagram, after the IP header.

Table 2 *ICMP Packet Format*

Type	Name	Codes
0	Echo reply	0—None
1	Unassigned	—
2	Unassigned	—
3	Destination unreachable	0—Net unreachable. 1—Host unreachable. 2—Protocol unreachable. 3—Port unreachable. 4—Fragmentation needed and DF bit set. 5—Source route failed. 6—Destination network unknown. 7—Destination host unknown. 8—Source host isolated. 9—Communication with destination network is administratively prohibited. 10—Communication with destination host is administratively prohibited. 11—Destination network unreachable for ToS. 12—Destination host unreachable for ToS.
4	Source quench	0—None.

Table 2 *ICMP Packet Format (continued)*

Type	Name	Codes
5	Redirect	0—None. 0—Redirect datagram for the network. 1—Redirect datagram for the host. 2—Redirect datagram for the ToS and network. 3—Redirect datagram for the ToS and host.
6	Alternate host address	0—Alternate address for host.
7	Unassigned	—
8	Echo	0—None.
9	Router advertisement	0—None.
10	Router selection	0—None.
11	Time Exceeded	0—Time to live exceeded in transit.
12	Parameter problem	0—Pointer indicates the error. 1—Missing a required option. 2—Bad length.
13	Timestamp	0—None.
14	Timestamp reply	0—None.
15	Information request	0—None.
16	Information reply	0—None.
17	Address mask request	0—None.
18	Address mask reply	0—None.
19	Reserved (for security)	—
20–29	Reserved (for robustness experiment)	—
30	Trace route	—
31	Datagram conversion error	—
32	Mobile host redirect	—
33	IPv6 where-are-you	—
34	IPv6 I-am-here	—
35	Mobile registration request	—
36	Mobile registration reply	—
37–255	Reserved	—

Layer 2 Information Capture Using NetFlow Layer 2 and Security Monitoring Exports

The NetFlow Layer 2 and Security Monitoring Exports feature has the ability to capture the values of the MAC address and VLAN ID fields from flows. The two supported VLAN types are 802.1q and the Cisco Inter-Switch Link (ISL) protocol. This section explains the following concepts:

- [Understanding Layer 2 MAC Address Fields](#)
- [Understanding Layer 2 VLAN ID Fields](#)

Understanding Layer 2 MAC Address Fields

The new Layer 2 fields for which the NetFlow Layer 2 and Security Monitoring Exports feature captures the values are as follows:

- The source MAC address field from frames that are received by the NetFlow router
- The destination MAC address field from frames that are transmitted by the NetFlow router
- The VLAN ID field from frames that are received by the NetFlow router
- The VLAN ID field from frames that are transmitted by the NetFlow router

Figure 4 shows the Ethernet Type II and Ethernet 802.3 frame formats. The destination address field and the source address field in the frame formats are the MAC addresses values that are captured by NetFlow.

Figure 4 Ethernet Type II and 802.3 Frame Formats

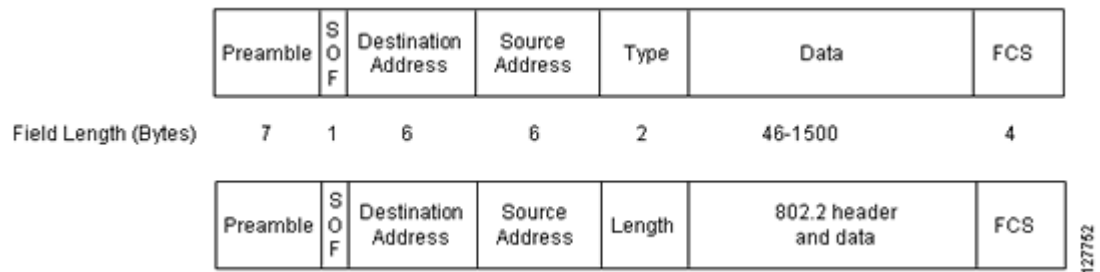

Table 3 explains the fields for the Ethernet frame formats.

Table 3 Ethernet Type II and 802.3 Frame Fields

Field	Description
Preamble	The entry in the Preamble field is an alternating pattern of 1s and 0s that tells receiving stations that a frame is coming. It also provides a means for the receiving stations to synchronize their clocks with the incoming bit stream.
SOF (Start of frame)	The SOF field holds an alternating pattern of 1s and 0s, ending with two consecutive 1-bits indicating that the next bit is the first bit of the first byte of the destination MAC address.

Table 3 *Ethernet Type II and 802.3 Frame Fields (continued)*

Field	Description
Destination Address	<p>The 48-bit destination address identifies which station(s) on the LAN should receive the frame. The first two bits of the destination MAC address are reserved for special functions:</p> <ul style="list-style-type: none"> • The first bit in the DA field indicates whether the address is an individual address (0) or a group address (1). • The second bit indicates whether the DA is globally administered (0) or locally administered (1). <p>The remaining 46 bits are a uniquely assigned value that identifies a single station, a defined group of stations, or all stations on the network.</p>
Source Address	<p>The 48-bit source address identifies which station transmitted the frame. The source address is always an individual address, and the leftmost bit in the SA field is always 0.</p>
Type or Length	<p>Type—In an Ethernet Type II frame, this part of the frame is used for the Type field. The Type field is used to identify the next layer protocol in the frame.</p> <p>Length—In an 802.3 Ethernet frame, this part of the frame is used for the Length field. The Length field is used to indicate the length of the Ethernet frame. The value can be from 46 to 1500 bytes.</p>
Data or 802.2 header and data	<p>(Ethernet type II) 46 to 1500 bytes of data</p> <p>or</p> <p>(802.3/802.2) 8 bytes of header and 38 to 1492 bytes of data.</p>
FCS (Frame Check Sequence)	<p>This field contains a 32-bit cyclic redundancy check (CRC) value, which is created by the sending station and is recalculated by the receiving station to check for damaged frames. The FCS is generated for the DA, SA, Type, and Data fields of the frame. The FCS does not include the data portion of the frame.</p>

Understanding Layer 2 VLAN ID Fields

NetFlow can capture the value in the VLAN ID field for 802.1q tagged VLANs and Cisco ISL encapsulated VLANs. This section describes the two types of VLANs:

- [Understanding 802.1q VLANs](#)
- [Understanding Cisco ISL VLANs](#)



Note

ISL and 802.1q are commonly called VLAN encapsulation protocols.

Understanding 802.1q VLANs

Devices that use 802.1q insert a four-byte tag into the original frame before it is transmitted. [Figure 5](#) shows the format of an 802.1q tagged Ethernet frame.

Figure 5 802.1q Tagged Ethernet Type II or 802.3 Frame

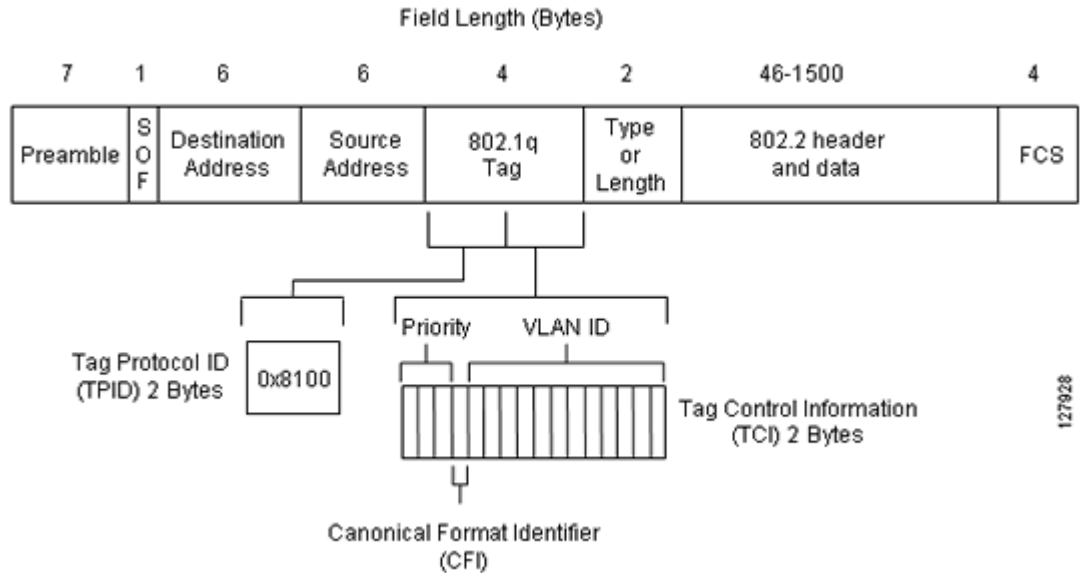

Table 4 describes the fields for 802.1q VLANs.

Table 4 802.1q VLAN Encapsulation Fields

Field	Description
DA, SA, Type or Length, Data, and FCS	Table 3 describes these fields.
Tag Protocol ID (TPID)	This 16-bit field is set to a value of 0x8100 to identify the frame as an IEEE 802.1q tagged frame.
Priority	Also known as user priority, this 3-bit field refers to the 802.1p priority. It indicates the frame priority level used for prioritizing traffic and is capable of representing 8 levels (0–7).
Tag Control Information	The 2-byte Tag Control Information field consists of two subfields: <ul style="list-style-type: none"> Canonical Format Indicator (CFI)—If the value of this 1-bit field is 1, then the MAC address is in noncanonical format. If the value of this field is 0, then the MAC address is in canonical format. VLAN ID—This 12-bit field uniquely identifies the VLAN to which the frame belongs. It can have a value from 0 to 4095.

Understanding Cisco ISL VLANs

ISL is a Cisco-proprietary protocol for encapsulating frames on a VLAN trunk. Devices that use ISL add an ISL header to the frame. This process is known as VLAN encapsulation. 802.1Q is the IEEE standard for tagging frames on a VLAN trunk. Figure 6 shows the format of a Cisco ISL-encapsulated Ethernet frame.

Figure 6 Cisco ISL Tagged Ethernet Frame

#of bits in the field	40	4	4	48	16	24	24	15	1	16	16	1 to 24575 bytes	32
Field Name	DA	TYPE	USER	SA	LEN	AAAA03(SNAP)	HSA	VLAN	BPDU	INDEX	RES	Encapsulated FRAME	FCS

12/7/55

Table 5 describes The fields for 802.1q VLANs.

Table 5 ISL VLAN Encapsulation

Field	Description
DA (destination address)	This 40-bit field is a multicast address and is set at 0x01-00-0C-00-00 or 0x03-00-0c-00-00. The receiving host determines that the frame is encapsulated in ISL by reading the 40-bit DA field and matching it to one of the two ISL multicast addresses.
TYPE	This 4-bit field indicates the type of frame that is encapsulated and could be used in the future to indicate alternative encapsulations. TYPE codes: <ul style="list-style-type: none"> • 0000 = Ethernet • 0001 = Token Ring • 0010 = FDDI • 0011 = ATM
USER	This 4-bit field is used to extend the meaning of the Frame TYPE field. The default USER field value is 0000. For Ethernet frames, the USER field bits 0 and 1 indicate the priority of the packet as it passes through the switch. Whenever traffic can be handled more quickly, the packets with this bit set should take advantage of the quicker path. However, such paths are not required. USER codes: <ul style="list-style-type: none"> • XX00 = Normal priority • XX01 = Priority 1 • XX10 = Priority 2 • XX11 = Highest priority
SA	This 48-bit field is the source address field of the ISL packet. It should be set to the 802.3 MAC address of the switch port transmitting the frame. The receiving device can ignore the SA field of the frame.
LEN	This 16-bit value field stores the actual packet size of the original packet. The LEN field represents the length of the packet in bytes, excluding the DA, TYPE, USER, SA, LEN, and FCS fields. The total length of the excluded fields is 18 bytes, so the LEN field represents the total length minus 18 bytes.
AAAA03(SNAP)	The AAAA03 SNAP field is a 24-bit constant value of 0xAAAA03.
HSA	This 24-bit field represents the upper three bytes (the manufacturer's ID portion) of the SA field. It must contain the value 0x00-00-0C.
VLAN	This 15-bit field is the virtual LAN ID of the packet. This value is used to mark frames on different VLANs.

Table 5 ISL VLAN Encapsulation (continued)

Field	Description
BPDU	The bit in the BPDU field is set for all BPDU packets that are encapsulated by the ISL frame. The BPDUs are used by the spanning tree algorithm to find out information about the topology of the network. This bit is also set for CDP and VTP frames that are encapsulated.
INDEX	This 16-bit field indicates the port index of the source of the packet as it exits the switch. It is used for diagnostic purposes only, and may be set to any value by other devices. It is ignored in received packets.
RES	This 16-bit field is used when Token Ring or FDDI packets are encapsulated with an ISL frame.
Encapsulated FRAME	This field contains the encapsulated Layer 2 frame.
FCS	The FCS field consists of 4 bytes. It includes a 32-bit CRC value, which is created by the sending station and is recalculated by the receiving station to check for damaged frames. The FCS covers the DA, SA, Length/Type, and Data fields. When an ISL header is attached to a Layer 2 frame, a new FCS is calculated over the entire ISL packet and added to the end of the frame. Note The addition of the new FCS does not alter the original FCS that is contained within the encapsulated frame.

NBAR Data Export

Network Based Application Recognition (NBAR) is a classification engine that recognizes and classifies a wide variety of protocols and applications, including web-based and other difficult-to-classify applications and protocols that use dynamic TCP/UDP port assignments.

When NBAR recognizes and classifies a protocol or application, the network can be configured to apply the appropriate application mapping with that protocol.

With Cisco IOS Release 12.2(18)ZYA2 on the Catalyst 6500 series switch equipped with a Supervisor 32/programmable intelligent services accelerator (PISA), the NBAR flow can be exported along with NetFlow export records.

The application-aware NetFlow feature integrates NBAR with NetFlow to provide the ability to export application information collected by NBAR using NetFlow. The application IDs created for the NetFlow Version 9 attribute export application names along with the standard attributes such as IP address and TCP/UDP port information. The NetFlow collector collects these flows based on source IP address and ID. The source ID refers to the unique identification for flows exported from a particular device.

The NBAR data exported to the NetFlow collector contains application mapping information. Using the NetFlow Data export options, the table containing the application IDs mapped to their application names is exported to the NetFlow collector. The mapping table is sent using the **ip flow-export template options nbar** command. The mapping information is refreshed every 30 minutes by default. You can configure the refresh interval by using the **ip flow-export template options timeout-rate** command.

Netflow export uses several aging mechanisms to manage the NetFlow cache. However, the NBAR data export intervals do not use NetFlow aging parameters.

Benefits of NBAR NetFlow Integration

NBAR enables network administrators to track variety of protocols and the amount of traffic generated by each protocol. NBAR also allows them to organize traffic into classes. These classes can then be used to provide different levels of service for network traffic, thereby allowing better network management by providing the right level of network resources for network traffic.

How to Configure NetFlow Layer 2 and Security Monitoring Exports

This section contains the following procedures:

- [Configuring NetFlow Layer 2 and Security Monitoring Exports, page 14](#)
- [Verifying NetFlow Layer 2 and Security Monitoring Exports, page 16](#) (Optional)
- [Configuring NBAR Support for NetFlow Exports](#)

Configuring NetFlow Layer 2 and Security Monitoring Exports

Prerequisites

CEF, dCEF, or fast switching for IP must be configured on your system before you configure the NetFlow Layer 2 and Security Monitoring Exports feature.

The optional “[Verifying NetFlow Layer 2 and Security Monitoring Exports](#)” task uses the **show ip cache verbose flow** command to display the values of the fields that you have configured the NetFlow Layer 2 and Security Monitoring Exports feature to capture. In order for you to view the values of the fields that you configured the NetFlow Layer 2 and Security Monitoring Exports feature to capture, your router must forward the IP traffic that meets the criteria for these fields. For example, if you configure the **ip flow-capture ipid** command, your router must be forwarding IP datagrams to capture the IP ID values from the IP datagrams in the flow.

If you want to capture the values of the Layer 3 IP fragment offset field from the IP headers in your IP traffic using the **ip flow-capture fragment-offset** command, your router must be running Cisco IOS 12.4(2)T or later release.

SUMMARY STEPS

1. **enable**
2. **configure terminal**
3. **ip flow-capture fragment-offset**
4. **ip flow-capture icmp**
5. **ip flow-capture ip-id**
6. **ip flow-capture mac-addresses**
7. **ip flow-capture packet-length**
8. **ip flow-capture ttl**
9. **ip flow-capture vlan-id**

10. **interface type** [*number* | *slot/port*]
11. **ip flow ingress**
and/or
ip flow egress
12. **exit**

DETAILED STEPS

	Command or Action	Purpose
Step 1	enable Example: Router> enable	Enables privileged EXEC mode. <ul style="list-style-type: none"> • Enter your password if prompted.
Step 2	configure terminal Example: Router# configure terminal	Enters global configuration mode.
Step 3	ip flow-capture fragment-offset Example: Router(config)# ip flow-capture fragment-offset	(Optional) Enables capturing the value of the IP fragment offset field from the first fragmented IP datagram in a flow.
Step 4	ip flow-capture icmp Example: Router(config)# ip flow-capture icmp	(Optional) Enables you to capture the value of the ICMP type and code fields from ICMP datagrams in a flow.
Step 5	ip flow-capture ip-id Example: Router(config)# ip flow-capture ip-id	(Optional) Enables you to capture the value of the IP-ID field from the first IP datagram in a flow.
Step 6	ip flow-capture mac-addresses Example: Router(config)# ip flow-capture mac-addresses	(Optional) Enables you to capture the values of the source and destination MAC addresses from the traffic in a flow.
Step 7	ip flow-capture packet-length Example: Router(config)# ip flow-capture packet-length	(Optional) Enables you to capture the minimum and maximum values of the packet length field from IP datagrams in a flow.
Step 8	ip flow-capture ttl Example: Router(config)# ip flow-capture ttl	(Optional) Enables you to capture the minimum and maximum values of the time-to-live (TTL) field from IP datagrams in a flow.
Step 9	ip flow-capture vlan-id Example: Router(config)# ip flow-capture vlan-id	(Optional) Enables you to capture the 802.1q or ISL VLAN-ID field from VLAN encapsulated frames in a flow that are received or transmitted on trunk ports.

	Command or Action	Purpose
Step 10	interface type [<i>number</i> <i>slot/port</i>] Example: Router(config)# interface ethernet 0/0	Enters interface configuration mode for the type of interface specified in the command.
Step 11	ip flow ingress and/or ip flow egress Example: Router(config-if)# ip flow ingress and/or Example: Router(config-if)# ip flow egress	Enables ingress NetFlow data collection on the interface. and/or Enables egress NetFlow data collection on the interface.
Step 12	exit Example: Router(config)# exit	Exits global configuration mode.

Verifying NetFlow Layer 2 and Security Monitoring Exports

Perform this task to verify the configuration of NetFlow Layer 2 and Security Monitoring Exports.

Restrictions

The “[Verifying NetFlow Layer 2 and Security Monitoring Exports](#)” uses the **show ip cache verbose flow** command. The following restrictions apply to using the **show ip cache verbose flow** command.

Displaying Detailed NetFlow Cache Information on Platforms Running Distributed Cisco Express Forwarding

On platforms running dCEF, NetFlow cache information is maintained on each line card or Versatile Interface Processor. If you want to use the **show ip cache verbose flow** command to display this information on a distributed platform, you must enter the command at a line card prompt.

Cisco 7500 Series Platform

To display detailed NetFlow cache information on a Cisco 7500 series router that is running distributed dCEF, enter the following sequence of commands:

```
Router# if-con slot-number
LC-slot-number# show ip cache verbose flow
```

For Cisco IOS Releases 12.3(4)T, 12.3(6), and 12.2(20)S and later, enter the following command to display detailed NetFlow cache information:

```
Router# execute-on slot-number show ip cache verbose flow
```

Cisco 12000 Series Platform

To display detailed NetFlow cache information on a Cisco 12000 Series Internet Router, enter the following sequence of commands:

```
Router# attach slot-number
LC-slot-number# show ip cache verbose flow
```

For Cisco IOS Releases 12.3(4)T, 12.3(6), and 12.2(20)S and later, enter the following command to display detailed NetFlow cache information:

```
Router# execute-on slot-number show ip cache verbose flow.
```

SUMMARY STEPS**1. show ip cache verbose flow****DETAILED STEPS****Step 1 show ip cache verbose flow**

The following output shows the working of NetFlow Layer 2 and Security Monitoring Exports feature by capturing the values from the Layer 2 and Layer 3 fields in the flows.

```
Router# show ip cache verbose flow
```

```
IP packet size distribution (25229 total packets):
  1-32  64  96 128 160 192 224 256 288 320 352 384 416 448 480
  .000 .000 .000 .000 .000 .000 .000 .000 .000 .000 .000 .000 .000 .000 .000

    512  544  576 1024 1536 2048 2560 3072 3584 4096 4608
    .000 .000 .000 .206 .793 .000 .000 .000 .000 .000 .000
```

```
IP Flow Switching Cache, 278544 bytes
  6 active, 4090 inactive, 17 added
  505 ager polls, 0 flow alloc failures
  Active flows timeout in 1 minutes
  Inactive flows timeout in 10 seconds
IP Sub Flow Cache, 25736 bytes
  12 active, 1012 inactive, 39 added, 17 added to flow
  0 alloc failures, 0 force free
  1 chunk, 1 chunk added
  last clearing of statistics never
```

Protocol	Total Flows	Flows /Sec	Packets /Flow	Bytes /Pkt	Packets /Sec	Active (Sec) /Flow	Idle (Sec) /Flow
TCP-Telnet	1	0.0	362	940	2.7	60.2	0.0
TCP-FTP	1	0.0	362	840	2.7	60.2	0.0
TCP-FTPD	1	0.0	362	840	2.7	60.1	0.1
TCP-SMTP	1	0.0	361	1040	2.7	60.0	0.1
UDP-other	5	0.0	1	66	0.0	1.0	10.6
ICMP	2	0.0	8829	1378	135.8	60.7	0.0
Total:	11	0.0	1737	1343	147.0	33.4	4.8

SrcIf	SrcIPaddress	DstIf	DstIPaddress	Pr	TOS	Flgs	Pkts
Port Msk AS		Port Msk AS	NextHop	B/Pk			Active
Et0/0.1	10.251.138.218	Et1/0.1	172.16.10.2	06	80	00	65
0015 /0 0		0015 /0 0	0.0.0.0			840	10.8
MAC: (VLAN id)	aaaa.bbbb.cc03	(005)	aaaa.bbbb.cc06	(006)			
Min plen:	840		Max plen:	840			
Min TTL:	59		Max TTL:	59			
IP id:	0						

Configuring NBAR Support for NetFlow Exports

Perform this task to export NBAR data to NetFlow Collector.

Prerequisites

You must enable NetFlow Version 9 and NBAR before you configure NBAR data export.

You must add and configure the following fields to the Cisco NetFlow Collector Software to identify the flow exported by the NBAR data export feature:

- `app_id` field as an integer with NumericID of 95
- `app_name` field as a UTF-8 String with NumericID of 96
- `sub_app_id` field as an Integer with NumericID of 97
- `biflowDirection` field as an Integer with NumericID of 239



Note The `biflowDirection` field provides information about the host that initiates the session. The size of this field is one byte. RFC 5103 provides details for using this field.

Restrictions

NBAR support can be configured only with NetFlow Version 9 format. If you try to configure NBAR data export with other versions, the following error message appears:

```
1d00h: %FLOW : Export version 9 not enabled
```

The NBAR data export does not use NetFlow aging parameters.

SUMMARY STEPS

1. **enable**
2. **configure terminal**
3. **ip flow-export version**
4. **ip flow-export nbar**
5. **ip flow-export template options nbar**
6. **exit**
7. **show ip flow export nbar**
8. **clear ip flow stats nbar**

DETAILED STEPS

Step 1	enable Example: Router> enable	Enables privileged EXEC mode. <ul style="list-style-type: none">• Enter your password if prompted.
Step 2	configure terminal Example: Router# configure terminal	Enters global configuration mode.
Step 3	ip flow-export version 9 Example: Router(config)# ip flow-capture version 9	Enables the Version 9 format to export NetFlow cache entries.
Step 4	ip flow-capture nbar Example: Router(config)# ip flow-capture nbar	Enables you to capture the NBAR data in NetFlow export records.
Step 5	ip flow-export template options nbar Example: Router(config)# ip flow-export template options nbar	Exports application mapping information to NetFlow data collector.
Step 6	exit Example: Router(config)# exit	Exits global configuration mode.
Step 7	show ip flow export nbar Example: Router # show ip flow export nbar	(Optional) Displays NBAR export records.
Step 8	clear ip flow stats nbar Example: Router# clear ip flow stats nbar	(Optional) Clears NetFlow accounting statistics for NBAR.

Configuration Examples for NetFlow Layer 2 and Security Monitoring Exports

This section provides the following configuration examples:

- [Configuring and Using NetFlow Layer 2 and Security Monitoring Exports to Analyze a Simulated FTP Attack: Example, page 20](#)
- [Configuring and Using NetFlow Layer 2 and Security Monitoring Exports to Analyze a Simulated ICMP Ping Attack: Example, page 26](#)

Configuring and Using NetFlow Layer 2 and Security Monitoring Exports to Analyze a Simulated FTP Attack: Example

The following example shows how to use the NetFlow Layer 2 and Security Monitoring Exports feature to find out whether your network is being attacked by a host that is sending fake FTP traffic in an attempt to overwhelm the FTP server. This attack might cause end users to see a degradation in the ability of the FTP server to accept new connections or to service existing connections.

This example uses the network shown in [Figure 7](#). Host A is sending fake FTP packets to the FTP server.

This example also shows you how to use the Layer 2 data captured by the NetFlow Layer 2 and Security Monitoring Exports feature to learn where the traffic is originating and what path it is taking through the network.

Figure 7 Test Network

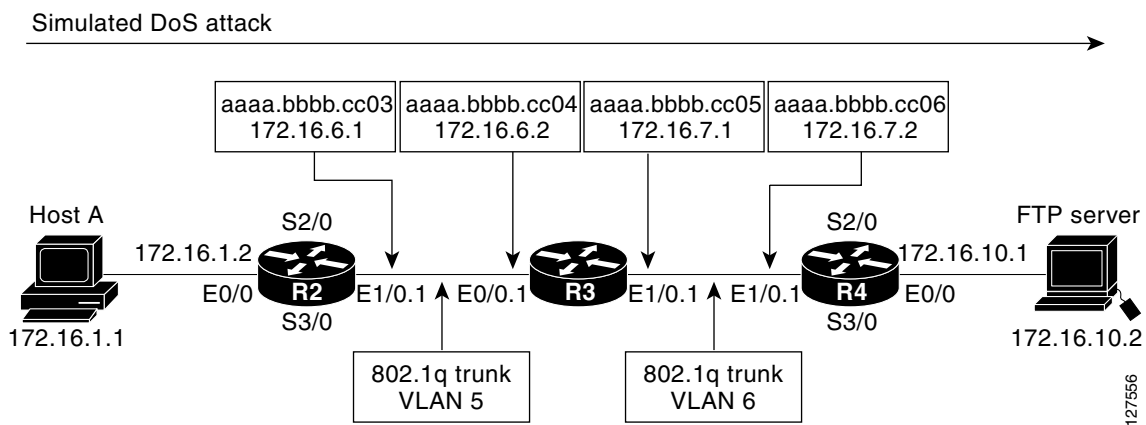

Tip

Keep track of the MAC addresses and IP addresses of the devices in your network. You can use them to analyze attacks and to resolve problems.



Note

This example does not include the `ip flow-capture icmp` command, which captures the value of the ICMP type and code fields. The use of the `ip flow-capture icmp` command is described in [“Configuring and Using NetFlow Layer 2 and Security Monitoring Exports to Analyze a Simulated ICMP Ping Attack: Example.”](#)

R2

```
!
hostname R2
!
interface Ethernet0/0
  mac-address aaaa.bbbb.cc02
  ip address 172.16.1.2 255.255.255.0
!
interface Ethernet1/0
  mac-address aaaa.bbbb.cc03
  no ip address
!
interface Ethernet1/0.1
```

```
encapsulation dot1Q 5
ip address 172.16.6.1 255.255.255.0
!
!
router rip
version 2
network 172.16.0.0
no auto-summary
!
```

R3

```
!
hostname R3
!
ip flow-capture fragment-offset
ip flow-capture packet-length
ip flow-capture ttl
ip flow-capture vlan-id
ip flow-capture ip-id
ip flow-capture mac-addresses
!
interface Ethernet0/0
mac-address aaaa.bbbb.cc04
no ip address
!
interface Ethernet0/0.1
encapsulation dot1Q 5
ip address 172.16.6.2 255.255.255.0
ip accounting output-packets
ip flow ingress
!
interface Ethernet1/0
mac-address aaaa.bbbb.cc05
no ip address
!
interface Ethernet1/0.1
encapsulation dot1Q 6
ip address 172.16.7.1 255.255.255.0
ip accounting output-packets
ip flow egress
!
router rip
version 2
network 172.16.0.0
no auto-summary
!
```

R4

```
!
hostname R4
!
interface Ethernet0/0
mac-address aaaa.bbbb.cc07
ip address 172.16.10.1 255.255.255.0
!
interface Ethernet1/0
mac-address aaaa.bbbb.cc06
no ip address
!
interface Ethernet1/0.1
encapsulation dot1Q 6
ip address 172.16.7.2 255.255.255.0
```

```

!
router rip
  version 2
  network 172.16.0.0
  no auto-summary
!

```

The **show ip cache verbose flow** command displays the NetFlow flows that have been captured from the FTP traffic that Host A is sending.

The fields that have the values captured by the **ip flow-capture** command are in [Table 9](#). These are the fields and the values that are used to analyze the traffic for this example. The other fields captured by the **show ip cache verbose flow** command are explained in [Table 6](#), [Table 7](#), and [Table 8](#).

```

R3# show ip cache verbose flow
IP packet size distribution (3596 total packets):
  1-32  64  96 128 160 192 224 256 288 320 352 384 416 448 480
    .000 .003 .000 .000 .000 .000 .000 .000 .000 .000 .000 .000 .000 .000 .000

    512 544 576 1024 1536 2048 2560 3072 3584 4096 4608
    .000 .000 .000 .995 .000 .000 .000 .000 .000 .000 .000

```

The preceding output shows the percentage distribution of packets by size. In this display, 99.5 percent of the packets fall in the 1024-byte size range, and 0.3 percent fall in the 64-byte range.

The next section of the output can be divided into four parts. The section and the table corresponding to each are as follows:

- Field Descriptions in the NetFlow Cache Section of the Output ([Table 6 on page 23](#))
- Field Descriptions in the Activity by Protocol Section of the Output ([Table 7 on page 24](#))
- Field Descriptions in the NetFlow Record Section of the Output ([Table 8 on page 24](#))
- NetFlow Layer 2 and Security Monitoring Exports Fields in the NetFlow Record Section of the Output ([Table 9 on page 25](#))

```

IP Flow Switching Cache, 278544 bytes
  5 active, 4091 inactive, 25 added
  719 aged polls, 0 flow alloc failures
  Active flows timeout in 1 minutes
  Inactive flows timeout in 10 seconds
IP Sub Flow Cache, 25736 bytes
  10 active, 1014 inactive, 64 added, 25 added to flow
  0 alloc failures, 0 force free
  1 chunk, 1 chunk added
  last clearing of statistics never

```

Protocol	Total	Flows	Packets	Bytes	Packets	Active(Sec)	Idle(Sec)
-----	Flows	/Sec	/Flow	/Pkt	/Sec	/Flow	/Flow
TCP-FTP	5	0.0	429	840	6.6	58.1	1.8
Total:	5	0.0	129	835	6.6	17.6	7.9

```

SrcIf          SrcIPAddress      DstIf          DstIPAddress    Pr TOS Flgs Pkts
Port Msk AS    Port Msk AS      NextHop        B/Pk Active
Et0/0.1        10.132.221.111   Et1/0.1        172.16.10.2     06 80 00   198
0015 /0 0      0015 /0 0        0.0.0.0        840   41.2
MAC: (VLAN id) aaaa.bbbb.cc03 (005)    aaaa.bbbb.cc06 (006)
Min plen:      840                Max plen:      840
Min TTL:       59                Max TTL:       59
IP id:         0

```

SrcIf	SrcIPAddress	DstIf	DstIPAddress	Pr	TOS	Flgs	Pkts
Port Msk AS	Port Msk AS	NextHop	B/Pk	Active			
Et0/0.1	10.132.221.111	Et1/0.1	172.16.10.2	06	80	00	198
0015 /0 0		0015 /0 0	0.0.0.0				840 41.2
MAC: (VLAN id)	aaaa.bbbb.cc03 (005)		aaaa.bbbb.cc06 (006)				
Min plen:	840		Max plen:	840			
Min TTL:	59		Max TTL:	59			
IP id:	0						

```

Et0/0.1        10.251.138.218   Et1/0.1        172.16.10.2     06 80 00   198
0015 /0 0      0015 /0 0        0.0.0.0        840   41.2
MAC: (VLAN id) aaaa.bbbb.cc03 (005)    aaaa.bbbb.cc06 (006)

```

```

Min plen:      840                               Max plen:      840
Min TTL:       59                               Max TTL:       59
IP id:         0

Et0/0.1        10.10.12.1      Et1/0.1        172.16.10.2    06 80 00      203
0015 /0 0      0015 /0 0      0.0.0.0        840           42.2
MAC: (VLAN id) aaaa.bbbb.cc03 (005)          aaaa.bbbb.cc06 (006)
Min plen:      840                               Max plen:      840
Min TTL:       59                               Max TTL:       59
IP id:         0

Et0/0.1        10.231.185.254  Et1/0.1        172.16.10.2    06 80 00      203
0015 /0 0      0015 /0 0      0.0.0.0        840           42.2
MAC: (VLAN id) aaaa.bbbb.cc03 (005)          aaaa.bbbb.cc06 (006)
Min plen:      840                               Max plen:      840
Min TTL:       59                               Max TTL:       59
IP id:         0

Et0/0.1        10.71.200.138   Et1/0.1        172.16.10.2    06 80 00      203
0015 /0 0      0015 /0 0      0.0.0.0        840           42.2
MAC: (VLAN id) aaaa.bbbb.cc03 (005)          aaaa.bbbb.cc06 (006)
Min plen:      840                               Max plen:      840
Min TTL:       59                               Max TTL:       59
IP id:         0

R3#

```

Table 6 describes the significant fields shown in the NetFlow cache section of the output.

Table 6 Field Descriptions in the NetFlow Cache Section of the Output

Field	Description
bytes	Number of bytes of memory used by the NetFlow cache.
active	Number of active flows in the NetFlow cache at the time this command was entered.
inactive	Number of flow buffers that are allocated in the NetFlow cache but that were not assigned to a specific flow at the time this command was entered.
added	Number of flows created since the start of the summary period.
ager polls	Number of times the NetFlow code caused entries to expire (used by Cisco Customer Support Engineers (CSE) for diagnostic purposes).
flow alloc failures	Number of times the NetFlow code tried to allocate a flow but could not.
last clearing of statistics	The period of time that has passed since the clear ip flow stats privileged EXEC command was last executed. The standard time output format of hours, minutes, and seconds (hh:mm:ss) is used for a period of time less than 24 hours. This time output changes to hours and days after the time exceeds 24 hours.

Table 7 describes the significant fields shown in the activity by protocol section of the output.

Table 7 *Field Descriptions in the Activity by Protocol Section of the Output*

Field	Description
Protocol	IP protocol and the well-known port number. (Refer to http://www.iana.org/Protocol Assignment Number Services , for the latest RFC values.) Note Only a small subset of all protocols is displayed.
Total Flows	Number of flows for this protocol since the last time statistics were cleared.
Flows/Sec	Average number of flows for this protocol per second; equal to the total flows divided by the number of seconds for this summary period.
Packets/Flow	Average number of packets for the flows for this protocol; equal to the total packets for this protocol divided by the number of flows for this protocol for this summary period.
Bytes/Pkt	Average number of bytes for the packets for this protocol; equal to the total bytes for this protocol divided by the total number of packets for this protocol for this summary period.
Packets/Sec	Average number of packets for this protocol per second; equal to the total packets for this protocol divided by the total number of seconds for this summary period.
Active(Sec)/Flow	Number of seconds from the first packet to the last packet of an expired flow divided by the number of total flows for this protocol for this summary period.
Idle(Sec)/Flow	Number of seconds observed from the last packet in each nonexpired flow for this protocol until the time at which the show ip cache verbose flow command was entered divided by the total number of flows for this protocol for this summary period.

Table 8 describes the significant fields in the NetFlow record section of the output.

Table 8 *Field Descriptions in the NetFlow Record Section of the Output*

Field	Description
SrcIf	Interface on which the packet was received.
Port Msk AS	Source port number (displayed in hexadecimal format), IP address mask, and autonomous system number. This is always set to 0 in MPLS flows.
SrcIPAddress	This is the source IP address of the traffic in the five flows. The traffic is using five different IP source addresses <ul style="list-style-type: none"> • 10.132.221.111 • 10.251.138.218 • 10.10.12.1 • 10.231.185.254 • 10.71.200.138
DstIf	Interface from which the packet was transmitted. Note If an asterisk (*) immediately follows the DstIf field, the flow being shown is an egress flow.

Table 8 *Field Descriptions in the NetFlow Record Section of the Output (continued)*

Field	Description
Port Msk AS	Source port number (displayed in hexadecimal format), IP address mask, and autonomous system number. The value of this field is always set to 0 in Multiprotocol Label Switching (MPLS) flows.
DstIPAddress	This is the destination IP address of the traffic. Note 172.17.10.2 is the IP address of the FTP server.
NextHop	The Border Gateway Protocol (BGP) next-hop address. This is always set to 0 in MPLS flows.
Pr	IP protocol “well-known” port number, displayed in hexadecimal format. (Refer to http://www.iana.org , <i>Protocol Assignment Number Services</i> , for the latest RFC values.)
ToS	Type of service, displayed in hexadecimal format.
B/Pk	Average number of bytes observed for the packets seen for this flow.
Flgs	TCP flags, shown in hexadecimal format. This value is the result of bitwise OR of the TCP flags from all packets in the flow.
Pkts	Number of packets in this flow.
Active	Time the flow has been active.

Table 9 describes the fields and values for the NetFlow Traffic Classification and Identification fields for the NetFlow record section of the output.

Table 9 *NetFlow Layer 2 and Security Monitoring Exports Fields in the NetFlow Record Section of the Output*

Field	Description
MAC	These are the source and destination MAC addresses from the traffic. The source and destination MAC address are read from left to right in the output. <ul style="list-style-type: none"> The traffic is being received from MAC address aaa.bbb.cc03. Note This MAC address is interface 1/0.1 on router R2. <ul style="list-style-type: none"> The traffic is being transmitted to MAC address aaa.bbb.cc06. Note This MAC address is interface 1/0.1 on router R4.
VLAN id	These are the source and destination VLAN IDs. The source and destination VLAN IDs are read from left to right in the output. <ul style="list-style-type: none"> The traffic is being received from VLAN 5. The traffic is being transmitted to VLAN 6.
Min plen	This is the minimum packet length for the packets captured in the five flows. The current value is 840.
Max plen	This is the maximum packet length for the packets captured in the five flows. The current value is 840.

Table 9 *NetFlow Layer 2 and Security Monitoring Exports Fields in the NetFlow Record Section of the Output (continued)*

Field	Description
Min TTL	This is the minimum time-to-live (TTL) for the packets captured in the five flows. The current value is 59.
Max TTL	This is the maximum TTL for the packets captured in the five flows. The current value is 59.
IP id	This is the IP identifier field for the traffic in the five flows. The current value is 0.

The fact that the Layer 3 TTL, identifier, and packet length fields in the five flows have the same values is a good indication that this traffic is a DoS attack. If this data had been captured from real traffic, the values would typically be different. The fact that all six of these flows have a TTL value of 59 indicates that this traffic is originating from points that are the same distance away from R3. Real user traffic would normally be arriving from many different distances away; therefore the TTL values would be different.

If this traffic is identified as a DoS attack (based on the data captured in the Layer 3 fields), you can use the Layer 2 information in the flows to identify the path the traffic is taking through the network. In this example, the traffic is being sent to R3 on VLAN 5 by R2. You can demonstrate that R2 is transmitting the traffic over interface 1/0.1 because the source MAC address (aaaa.bbb.cc03) belongs to 1/0.1 on R2. You can identify that R3 is transmitting the traffic using VLAN 6 on interface 1/0.1 to interface 1/0.1 on R4 because the destination MAC address (aaaa.bbbb.cc06) belongs to interface 1/0.1 on R4.

You can use this information to develop a plan to mitigate this attack. One possible way to mitigate this attack is by configuring an extended IP access list that blocks FTP traffic from any host with a source address that is on the 10.0.0.0 network. Another possible solution is to configure a default route for the 10.0.0.0 network that points to the null interface on the router.



Caution

Each of these solutions blocks traffic from legitimate hosts on the 10.0.0.0 network. Therefore these solutions should be used only temporarily while you identify the point of origin of the attack and decide how to stop it there.

Configuring and Using NetFlow Layer 2 and Security Monitoring Exports to Analyze a Simulated ICMP Ping Attack: Example

The following example shows how to use the NetFlow Layer 2 and Security Monitoring Exports feature to find out that your network is being attacked by ICMP traffic. It uses the network shown in [Figure 7](#). Host A is sending very large ICMP ping packets to the FTP server.

R2

```
!
hostname R2
!
interface Ethernet0/0
 mac-address aaaa.bbbb.cc02
 ip address 172.16.1.2 255.255.255.0
```

```
!  
interface Ethernet1/0  
  mac-address aaaa.bbbb.cc03  
  no ip address  
!  
interface Ethernet1/0.1  
  encapsulation dot1Q 5  
  ip address 172.16.6.1 255.255.255.0  
!  
!  
router rip  
  version 2  
  network 172.16.0.0  
  no auto-summary  
!
```

R3

```
!  
hostname R3  
!  
ip flow-capture fragment-offset  
ip flow-capture packet-length  
ip flow-capture ttl  
ip flow-capture vlan-id  
ip flow-capture icmp  
ip flow-capture ip-id  
ip flow-capture mac-addresses  
!  
interface Ethernet0/0  
  mac-address aaaa.bbbb.cc04  
  no ip address  
!  
interface Ethernet0/0.1  
  encapsulation dot1Q 5  
  ip address 172.16.6.2 255.255.255.0  
  ip accounting output-packets  
  ip flow ingress  
!  
interface Ethernet1/0  
  mac-address aaaa.bbbb.cc05  
  no ip address  
!  
interface Ethernet1/0.1  
  encapsulation dot1Q 6  
  ip address 172.16.7.1 255.255.255.0  
  ip accounting output-packets  
  ip flow egress  
!  
router rip  
  version 2  
  network 172.16.0.0  
  no auto-summary  
!
```

R4

```
!  
hostname R4  
!  
interface Ethernet0/0  
  mac-address aaaa.bbbb.cc07  
  ip address 172.16.10.1 255.255.255.0  
!
```

```

interface Ethernet1/0
  mac-address aaaa.bbbb.cc06
  no ip address
!
interface Ethernet1/0.1
  encapsulation dot1Q 6
  ip address 172.16.7.2 255.255.255.0
!
router rip
  version 2
  network 172.16.0.0
  no auto-summary
!

```

The **show ip cache verbose flow** command displays the NetFlow flows that have been captured from the ICMP traffic that Host A is sending.

The fields that have their values captured by the **ip flow-capture** command are explained in [Table 13](#). These are the fields and the values that are used to analyze the traffic for this example. The other fields captured by the **show ip cache verbose flow** command are explained in [Table 10](#), [Table 11](#) and [Table 12](#).

```

R3# show ip cache verbose flow
IP packet size distribution (5344 total packets):
  1-32  64  96 128 160 192 224 256 288 320 352 384 416 448 480
  .000 .000 .000 .000 .000 .000 .000 .000 .000 .000 .000 .000 .000 .000 .000

  512  544  576 1024 1536 2048 2560 3072 3584 4096 4608
  .000 .000 .000 .166 .832 .000 .000 .000 .000 .000 .000

```

The preceding output shows the percentage distribution of packets by size. In this display, 16.6 percent of the packets fall in the 1024-byte size range and 83.2 percent fall in the 1536-byte range.

The next section of the output can be divided into four sections. The section and the table corresponding to each are as follows:

- Field Descriptions in the NetFlow Cache Section of the Output ([Table 10 on page 29](#))
- Field Descriptions in the Activity by Protocol Section of the Output ([Table 11 on page 29](#))
- Field Descriptions in the NetFlow Record Section of the Output ([Table 12 on page 30](#))
- NetFlow Layer 2 and Security Monitoring Exports Fields in the NetFlow Record Section of the Output ([Table 13 on page 31](#))

```

IP Flow Switching Cache, 278544 bytes
  3 active, 4093 inactive, 7 added
  91 ager polls, 0 flow alloc failures
  Active flows timeout in 1 minutes
  Inactive flows timeout in 10 seconds
IP Sub Flow Cache, 25736 bytes
  7 active, 1017 inactive, 17 added, 7 added to flow
  0 alloc failures, 0 force free
  1 chunk, 0 chunks added
  last clearing of statistics 00:01:13

```

Protocol	Total Flows	Flows /Sec	Packets /Flow	Bytes /Pkt	Packets /Sec	Active(Sec) /Flow	Idle(Sec) /Flow
ICMP	2	0.0	1500	1378	42.8	11.4	10.9
Total:	2	0.0	600	1378	42.9	11.5	10.8

```

SrcIf          SrcIPAddress      DstIf          DstIPAddress    Pr TOS Flgs  Pkts
Port Msk AS    Port Msk AS      NextHop         B/Pk Active
Et0/0.1       10.106.1.1        Et1/0.1        172.16.10.2    01 00 10   391
0000 /0 0      0800 /0 0        0.0.0.0        1500   8.6
MAC: (VLAN id) aaaa.bbbb.cc03 (005)      aaaa.bbbb.cc06 (006)

```

```

Min plen:      1500                      Max plen:      1500
Min TTL:       59                       Max TTL:       59
ICMP type:     8                         ICMP code:     0
IP id:         13499

Et0/0.1       10.106.1.1                 Et1/0.1       172.16.10.2    01 00 00    1950
0000 /0 0     0000 /0 0                   0.0.0.0      1354         8.6
MAC: (VLAN id) aaaa.bbbb.cc03 (005)     aaaa.bbbb.cc06 (006)
Min plen:     772                         Max plen:     1500
Min TTL:      59                         Max TTL:      59
ICMP type:    0                         ICMP code:    0
IP id:        13499                      FO:          185

R3#

```

Table 10 describes the significant fields shown in the NetFlow cache lines of the output.

Table 10 *Field Descriptions in the NetFlow Cache Section of the Output*

Field	Description
bytes	Number of bytes of memory used by the NetFlow cache.
active	Number of active flows in the NetFlow cache at the time this command was entered.
inactive	Number of flow buffers that are allocated in the NetFlow cache but that were not assigned to a specific flow at the time this command was entered.
added	Number of flows created since the start of the summary period.
ager polls	Number of times the NetFlow code caused entries to expire (used by Cisco Customer Support Engineers (CSE) for diagnostic purposes).
flow alloc failures	Number of times the NetFlow code tried to allocate a flow but could not.
last clearing of statistics	The period of time that has passed since the clear ip flow stats privileged EXEC command was last executed. The standard time output format of hours, minutes, and seconds (hh:mm:ss) is used for a period of time less than 24 hours. This time output changes to hours and days after the time exceeds 24 hours.

Table 11 describes the significant fields shown in the activity by protocol lines of the output.

Table 11 *Field Descriptions in the Activity by Protocol Section of the Output*

Field	Description
Protocol	IP protocol and the well-known port number. (Refer to http://www.iana.org/Protocol Assignment Number Services , for the latest RFC values.) Note Only a small subset of all protocols is displayed.
Total Flows	Number of flows for this protocol since the last time statistics were cleared.
Flows/Sec	Average number of flows for this protocol per second; equal to the total flows divided by the number of seconds for this summary period.
Packets/Flow	Average number of packets for the flows for this protocol; equal to the total packets for this protocol divided by the number of flows for this protocol for this summary period.

Table 11 *Field Descriptions in the Activity by Protocol Section of the Output (continued)*

Field	Description
Bytes/Pkt	Average number of bytes for the packets for this protocol; equal to the total bytes for this protocol divided by the total number of packets for this protocol for this summary period.
Packets/Sec	Average number of packets for this protocol per second; equal to the total packets for this protocol divided by the total number of seconds for this summary period.
Active(Sec)/Flow	Number of seconds from the first packet to the last packet of an expired flow divided by the total number of flows for this protocol for this summary period.
Idle(Sec)/Flow	Number of seconds observed from the last packet in each nonexpired flow for this protocol until the time at which the show ip cache verbose flow command was entered divided by the total number of flows for this protocol for this summary period.

Table 12 describes the significant fields in the NetFlow record lines of the output.

Table 12 *Field Descriptions in the NetFlow Record Section of the Output*

Field	Description
SrcIf	Interface on which the packet was received.
Port Msk AS	Source port number (displayed in hexadecimal format), IP address mask, and autonomous system number. The value of this field is always set to 0 in MPLS flows.
SrcIPAddress	IP address of the device that transmitted the packet. The sending host is using 10.106.1.1 as the source IP address.
DstIf	Interface from which the packet was transmitted. Note If an asterisk (*) immediately follows the DstIf field, the flow being shown is an egress flow.
Port Msk AS	Destination port number (displayed in hexadecimal format), IP address mask, and autonomous system. This is always set to 0 in MPLS flows.
DstIPAddress	IP address of the destination device.
NextHop	The BGP next-hop address. This is always set to 0 in MPLS flows.
Pr	IP protocol “well-known” port number, displayed in hexadecimal format. (Refer to http://www.iana.org , <i>Protocol Assignment Number Services</i> , for the latest RFC values.)
ToS	Type of service, displayed in hexadecimal format.
B/Pk	Average number of bytes observed for the packets seen for this flow.
Flgs	TCP flags, shown in hexadecimal format. This value is the result of bitwise OR of the TCP flags from all packets in the flow.
Pkts	Number of packets in this flow.
Active	Time the flow has been active.

Table 13 describes the fields and values for the NetFlow Traffic Classification and Identification fields for the NetFlow record lines of the output.

Table 13 *NetFlow Layer 2 and Security Monitoring Exports Fields in the NetFlow Record Section of the Output*

Field	Description
MAC	<p>These are the source and destination MAC addresses from the traffic. The source and destination MAC address are read from left to right in the output.</p> <ul style="list-style-type: none"> The traffic is being received from MAC address aaa.bbb.cc03. <p>Note This MAC address is interface 1/0.1 on router R2.</p> <ul style="list-style-type: none"> The traffic is being transmitted to MAC address aaa.bbb.cc06. <p>Note This MAC address is interface 1/0.1 on router R4.</p>
VLAN id	<p>These are the source and destination VLAN IDs. The source and destination VLAN IDs are read from left to right in the output.</p> <ul style="list-style-type: none"> The traffic is being received from VLAN 5. The traffic is being transmitted to VLAN 6.
Min plen	<p>This is the minimum packet length for the packets captured in the two flows. The current value for the first flow is 1500. The current value for the second flow is 772.</p>
Max plen	<p>This is the maximum packet length for the packets captured in the two flows. The current value for the first flow is 1500. The current value for the second flow is 1500.</p>
Min TTL	<p>This is the minimum time-to-live (TTL) for the packets captured in the two flows. The current value is 59.</p>
Max TTL	<p>This is the maximum TTL for the packets captured in the two flows. The current value is 59.</p>
IP id	<p>This is the IP identifier field for the traffic in the flows. The current value is 0 for all three flows.</p>
ICMP type	<p>This is the Internet Control Message Protocol (ICMP) type field from the ICMP datagram captured in the first flow. The value is: 8</p>
ICMP code	<p>This is the ICMP code field from the ICMP datagram captured in the third flow. The value is: 0</p>
FO	<p>This is the value of the fragment offset field from the first fragmented datagram in the second flow. The value is: 185</p>

There are two ICMP flows shown in the output. You can tell that they are from the same ICMP datagram because they have the same IP ID field value of 13499. When two ICMP flows have the same IP ID value, the ICMP datagram being analyzed has been fragmented. The first flow has the ICMP type field set to 8, which indicates that this is an ICMP echo request (ping) datagram. The value of 185 in the fragment offset (FO) field in the second flow shows where this fragment will be placed in the memory buffer of the FTP server as the server reassembles the ICMP datagram. The value of 185 is applicable only to the first fragment of this datagram. The subsequent values will be greater because they take into account the previous fragments.

The value of 0 in the ICMP type field of the second flow does not mean that this flow is an ICMP echo reply as [Table 2](#) shows. In this case the ICMP type field value is set to 0 because the ICMP headers for fragments of ICMP datagrams do not have the type and code fields. The default value of 0 is inserted instead.

**Note**

If this data were captured from a real ICMP attack, it would probably have more than one flow.

Although, you cannot find out the original size of the ICMP datagram from the information shown by the **show ip cache verbose flow**, the fact that it was large enough to be fragmented in transit is a good indication that this is not a normal ICMP datagram. Notice the values in the minimum and maximum packet length fields for both flows. The values for both fields are set to 1500 for the first flow. The value for the minimum packet length is set to 772 and the value for the maximum packet length is set to 1500 for the second flow.

If this traffic is identified as a DoS attack based on the data captured in the Layer 3 fields, you can use the Layer 2 information in the flows to identify the path that the traffic is taking through the network. In this example, the traffic is being sent to R3 on VLAN 5 by R2. You can demonstrate that R2 is transmitting the traffic over interface 1/0.1 because the source MAC address (aaaa.bbb.cc03) belongs to 1/0.1 on R2. You can demonstrate that R3 is transmitting the traffic using VLAN 6 on interface 1/0.1 to interface 1/0.1 on R4, because the destination MAC address (aaaa.bbbb.cc06) belongs to interface 1/0.1 on R4.

You can use this information to mitigate this attack. One possible way to mitigate this attack is by configuring an extended IP access list that blocks ICMP traffic from any host with a source address that is on the 10.0.0.0 network. Another possible solution is to configure a default route for the 10.0.0.0 network that points to the null interface on the router.

**Caution**

Each of these solutions blocks traffic from legitimate hosts on the 10.0.0.0 network. Therefore these solutions should only be used temporarily while you identify the point of origin of the attack and decide how to stop it there.

Configuring NBAR Support for NetFlow Exports: Example

The following example shows how to configure NBAR support for NetFlow exports:

```
Router(config)# ip flow-export version 9
Router(config)# ip flow-capture nbar
Router(config)# ip flow-export template options nbar
Router# exit
```

The following example shows sample output of the **show ip flow export nbar** command:

```
Router # show ip flow export nbar
Nbar netflow is enabled
10 nbar flows exported
0 nbar flows failed to export due to lack of internal buffers
```

The following example shows how to clear NBAR data from NetFlow accounting statistics:

```
Router # clear ip flow stats nbar
```

Additional References

The following sections provide references related to NetFlow Layer 2 and Security Monitoring Exports.

Related Documents

Related Topic	Document Title
Overview of Cisco IOS NetFlow	Cisco IOS NetFlow Overview
List of the features documented in the <i>Cisco IOS NetFlow Configuration Guide</i>	Cisco IOS NetFlow Features Roadmap
Overview of NBAR	Classifying Network Traffic Using NBAR
Configuring NBAR	Configuring NBAR Using the MQC
Configuring NBAR using protocol-discovery	Enabling Protocol Discovery
NetFlow commands	Cisco IOS NetFlow Command Reference
Information for installing, starting, and configuring the CNS NetFlow Collection Engine	Cisco CNS NetFlow Collection Engine Documentation

Standards

Standards	Title
There are no new or modified standards associated with this feature	—

MIBs

MIBs	MIBs Link
There are no new or modified MIBs associated with this feature	To locate and download MIBs for selected platforms, Cisco IOS releases, and feature sets, use Cisco MIB Locator found at the following URL: http://www.cisco.com/go/mibs

RFCs

RFC	Title
5103	Bidirectional Flow Export Using IP Flow Information Export (IPFIX)

Technical Assistance

Description	Link
The Cisco Technical Support website contains thousands of pages of searchable technical content, including links to products, technologies, solutions, technical tips, and tools. Registered Cisco.com users can log in from this page to access even more content.	http://www.cisco.com/techsupport

Feature Information for NetFlow Layer 2 and Security Monitoring Exports

[Table 14](#) lists the features in this module and provides links to specific configuration information. Only features that were introduced or modified in Cisco IOS Releases 12.2(1) or 12.0(3)S or a later release appear in the table.

Not all commands may be available in your Cisco IOS software release. For details on when support for a specific command was introduced, see the command reference documentation.

For information on a feature in this technology that is not documented here, see the [Cisco IOS NetFlow Features Roadmap](#).

Cisco IOS software images are specific to a Cisco IOS software release, a feature set, and a platform. Use Cisco Feature Navigator to find information about platform support and Cisco IOS software image support. Access Cisco Feature Navigator at <http://www.cisco.com/go/fn>. You must have an account on Cisco.com. If you do not have an account or have forgotten your username or password, click **Cancel** at the login dialog box and follow the instructions that appear.



Note

[Table 14](#) lists only the Cisco IOS software release that introduced support for a given feature in a given Cisco IOS software release train. Unless noted otherwise, subsequent releases of that Cisco IOS software release train also support that feature.

Table 14 **Feature Information for NetFlow Layer 2 and Security Monitoring Exports**

Feature Name	Releases	Feature Configuration Information
NetFlow Layer 2 and Security Monitoring Exports	12.3(14)T 12.2(33)SRA	<p>The NetFlow Layer 2 and Security Monitoring Exports feature enables the capture of values from fields in Layer 2 and Layer 3 of IP traffic for accounting and security analysis.</p> <p>The following sections provide information about this feature:</p> <ul style="list-style-type: none"> • NetFlow Layer 2 and Security Monitoring, page 2 • Configuring NetFlow Layer 2 and Security Monitoring Exports, page 14 • Verifying NetFlow Layer 2 and Security Monitoring Exports, page 16 <p>The following commands were modified by this feature: ip flow-capture, ip flow-export and show ip cache verbose flow.</p>
Support for capturing the value from the fragment offset field of IP headers added to NetFlow Layer 2 and Security Monitoring Exports ¹	12.4(2)T	<p>The fragment-offset keyword for the ip flow-capture command enables capturing the value of the IP fragment offset field from the first fragmented IP datagram in a flow.</p>
Application-aware NetFlow	12.2(18)ZYA2	<p>The application-aware NetFlow feature enables the capture of application information collected by PISA NBAR and exports using NetFlow Version 9.</p> <p>The following sections provide information about this feature:</p> <ul style="list-style-type: none"> • NBAR Data Export • Configuring NBAR Support for NetFlow Exports <p>The following commands were modified by this feature: ip flow-capture, ip flow-export template options, show ip flow export, and clear ip flow stats.</p>

1. This is a minor enhancement. Minor enhancements are not typically listed in Feature Navigator.

Glossary

export packet—A type of packet built by a device (for example, a router) with NetFlow services enabled. The packet is addressed to another device (for example, the NetFlow Collection Engine). The packet contains NetFlow statistics. The other device processes the packet (parses, aggregates, and stores information about IP flows).

flow—A set of packets with the same source IP address, destination IP address, protocol, source/destination ports, and type-of-service, and the same interface on which flow is monitored. Ingress flows are associated with the input interface, and egress flows are associated with the output interface.

NBAR—A classification engine in Cisco IOS Software that recognizes a wide variety of applications, including web-based and client/server applications.

NetFlow—Cisco IOS accounting feature that maintains per-flow information.

NetFlow Aggregation—A NetFlow feature that lets you summarize NetFlow export data on a Cisco IOS router before the data is exported to a NetFlow data collection system such as the NetFlow Collection Engine. This feature lowers bandwidth requirements for NetFlow export data and reduces platform requirements for NetFlow data collection devices.

NetFlow Collection Engine (formerly NetFlow FlowCollector)—Cisco application that is used with NetFlow on Cisco routers and Catalyst series switches. The NetFlow Collection Engine collects packets from the router that is running NetFlow and decodes, aggregates, and stores them. You can generate reports on various aggregations that can be set up on the NetFlow Collection Engine.

NetFlow v9—NetFlow export format Version 9. A flexible and extensible means of carrying NetFlow records from a network node to a collector. NetFlow Version 9 has definable record types and is self-describing for easier NetFlow Collection Engine configuration.

CCDE, CCENT, CCSI, Cisco Eos, Cisco HealthPresence, Cisco IronPort, the Cisco logo, Cisco Lumin, Cisco Nexus, Cisco Nurse Connect, Cisco StackPower, Cisco StadiumVision, Cisco TelePresence, Cisco Unified Computing System, Cisco WebEx, DCE, Flip Channels, Flip for Good, Flip Mino, Flip Video, Flip Video (Design), Flipshare (Design), Flip Ultra, and Welcome to the Human Network are trademarks; Changing the Way We Work, Live, Play, and Learn, Cisco Store, and Flip Gift Card are service marks; and Access Registrar, Aironet, AsyncOS, Bringing the Meeting To You, Catalyst, CCDA, CCDP, CCIE, CCIP, CCNA, CCNP, CCSP, CCVP, Cisco, the Cisco Certified Internetwork Expert logo, Cisco IOS, Cisco Press, Cisco Systems, Cisco Systems Capital, the Cisco Systems logo, Cisco Unity, Collaboration Without Limitation, EtherFast, EtherSwitch, Event Center, Fast Step, Follow Me Browsing, FormShare, GigaDrive, HomeLink, Internet Quotient, IOS, iPhone, iQuick Study, IronPort, the IronPort logo, LightStream, Linksys, MediaTone, MeetingPlace, MeetingPlace Chime Sound, MGX, Networkers, Networking Academy, Network Registrar, PCNow, PIX, PowerPanels, ProConnect, ScriptShare, SenderBase, SMARTnet, Spectrum Expert, StackWise, The Fastest Way to Increase Your Internet Quotient, TransPath, WebEx, and the WebEx logo are registered trademarks of Cisco Systems, Inc. and/or its affiliates in the United States and certain other countries.

All other trademarks mentioned in this document or website are the property of their respective owners. The use of the word partner does not imply a partnership relationship between Cisco and any other company. (0907R)

Any Internet Protocol (IP) addresses and phone numbers used in this document are not intended to be actual addresses and phone numbers. Any examples, command display output, network topology diagrams, and other figures included in the document are shown for illustrative purposes only. Any use of actual IP addresses or phone numbers in illustrative content is unintentional and coincidental.

© 2009 Cisco Systems, Inc. All rights reserved.